

# Chief Architect Premier X15

*Professional 3D Home Design Software*



## Reference Manual

*A description of the software interface, including drawing tools and settings.*

Chief Architect, Inc  
6500 N. Mineral Dr  
Coeur d'Alene, ID 83815  
[www.chiefarchitect.com](http://www.chiefarchitect.com)

3/28/2023

© 1990–2023 by Chief Architect, Inc. All rights reserved.

No part of this documentation or accompanying software may be reproduced or transmitted in any form or by any means, electronic or mechanical, including photocopying, recording, or by any information storage and retrieval system, without permission in writing from Chief Architect, Inc.

Chief Architect® is a registered trademark of Chief Architect, Inc.

This software uses the **FreeImage open source image library**. FreeImage is used under the FIPL license, version 1.0. See <https://freeimage.sourceforge.net> for details.

This software uses the **Ruby open source library**. See [www.ruby-lang.org](http://www.ruby-lang.org) for details.

This application incorporates **Teigha® software** pursuant to a license agreement with Open Design Alliance. Teigha® Copyright © 2003-2018 by Open Design Alliance. All rights reserved.

3D input device development tools and related technology are provided under license from **3Dconnexion**. © 3Dconnexion 1992 - 2018. All rights reserved.

The **Sentry Spelling-Checker Engine** © 1994–2003 Wintertree Software Inc.

This software uses **Intel’s Embree library**, which is licensed under the Apache License version 2.0. See <https://github.com/embree/embree> for details.

This software uses **Open CASCADE Technology**. See <https://www.opencascade.com> for details.

This software uses **Lib3DS**.

Open CASCADE Technology and Lib3DS are both used under the GNU Lesser General Public License version 2.1.

This software uses the **OpenCOLLADA SDK**. Copyright © 2008-2012 NetAllied Systems GmbH, Ravensburg, Germany.

This software uses **Precomputed Atmospheric Scattering**. Copyright © 2017, Eric Bruneton. All rights reserved. See [https://github.com/ebruneton/precomputed\\_atmospheric\\_scattering](https://github.com/ebruneton/precomputed_atmospheric_scattering) for details.

This software uses the **OpenVR SDK**. Copyright © 2015, Valve Corporation. All rights reserved. See <https://github.com/ValveSoftware/openvr> for details.

This software uses the **OpenCV open source computer vision library**. See <https://www.opencv.org> for details.

Precomputed Atmospheric Scattering, OpenVR, and OpenCV are all used under a 3-clause BSD License.

This software uses the **PDFium** PDF renderer, which is licensed under a three-clause BSD license and the Apache License version 2.0. Copyright 2014 PDFium Authors. All rights reserved.

This software uses **Intel® Open Image Denoise** which is part of the Intel® oneAPI Rendering Toolkit and is licensed under the Apache License version 2.0. All rights reserved. See <https://www.openimagedenoise.org/> for details.

All other trademarks and copyrights are the property of Chief Architect, Inc. or their respective owners.

Created in the United States of America.

Cover house designed by Michael Rust - Architect LLC.

# Contents

<b>Copyrights</b> .....	<b>2</b>	Template Files .....	87
<b>Program Overview</b> .....	<b>10</b>	Importing Default Settings .....	90
Dashboard .....	11	Reset to Defaults .....	91
The Chief Architect Premier Environment .....	12	General Plan Defaults Dialog .....	92
Using Input Devices .....	14	Preferences Dialog .....	95
View and Side Windows .....	17	Dialog Number/Angle Style Dialog .....	126
Menus, Toolbars, and Hotkeys .....	18	<b>Toolbars and Hotkeys</b> .....	<b>128</b>
Dialogs .....	19	Toolbar Arrangement .....	129
Edit Handles .....	23	Customizing Toolbars .....	131
The Status Bar .....	24	Creating Custom Toolbar Configurations .....	133
Message Boxes .....	25	Toolbar Customization Dialog .....	134
Preferences and Default Settings .....	26	Hotkeys .....	137
Drawing a Plan .....	27	Exporting and Importing Hotkeys .....	139
Viewing Your Plan .....	29	Gamepad Settings Dialog .....	140
Sharing Your Files with Clients .....	31	<b>Window and View Tools</b> .....	<b>143</b>
Getting Help .....	31	View Windows .....	144
About Chief Architect .....	32	Plan Views .....	146
Chief Architect Trial Software .....	32	Plan View Specification Dialog .....	148
<b>File Management</b> .....	<b>34</b>	Working in Multiple Views .....	150
Compatibility with Previous Versions .....	35	View Tools .....	152
Organizing Your Files .....	36	Zoom Tools .....	153
Chief Architect Premier Data .....	37	Fill Window .....	154
Creating a New Plan or Layout .....	38	Panning the Display .....	154
Saving, Exporting, and Backing Up Files .....	39	Closing Views and Files .....	155
Auto Archive .....	42	<b>Creating Objects</b> .....	<b>157</b>
Opening and Importing Files .....	44	Architectural vs CAD Objects .....	158
Plan Databases .....	46	Defaults and Preferences .....	158
Searching for Plans .....	48	Snap Behaviors .....	159
Linked and Referenced Files .....	51	Object Snaps .....	160
Backup Entire Plan or Layout .....	55	Angle Snaps .....	162
Exiting Chief Architect .....	56	Grid Snaps .....	163
<b>Project Planning</b> .....	<b>57</b>	Creating Objects .....	164
Project Browser .....	58	Copying and Pasting Objects .....	167
Time Tracker .....	60	<b>Displaying Objects</b> .....	<b>175</b>
Space Planning .....	62	Displaying Objects .....	176
Room Box Specification Dialog .....	64	Layers .....	176
Construction Lines .....	65	Layer Attributes .....	177
Construction Line Specification Dialog .....	66	Layer Display Options Dialog .....	179
The Reference Display .....	68	Layer Sets .....	182
Finding Objects .....	72	Layer Set Defaults .....	183
Plan Check .....	72	Layer Set Management .....	184
Loan Calculator .....	73	Active Layer Display Options .....	185
<b>Preferences and Default Settings</b> .....	<b>76</b>	Select Layer Dialog .....	186
Default Settings vs Preferences .....	77	Layer Panel .....	186
Dynamic Defaults .....	79	Object Layer Properties .....	187
Set as Default .....	79	Layer Painter, Eyedropper, and Hider .....	188
Multiple Saved Defaults .....	79	Exporting and Importing Layer Sets .....	189
Active Defaults Dialog .....	82	Drawing Groups .....	190
Default Sets .....	83	Display Toggles .....	191
Exporting and Importing Default Sets .....	86	Fill Styles .....	192

Fill Style Panel and Dialogs .....	193	CAD Blocks .....	329
Custom Patterns .....	196	CAD Block Management .....	333
Line Styles .....	199	CAD Block Specification Dialog .....	334
Line Style Specification Dialog .....	201	CAD Details .....	337
Color Chooser/Select Color Dialog .....	203	CAD Detail Specification Dialog .....	338
<b>Editing Objects .....</b>	<b>205</b>	Plot Plans and Plan Footprints .....	339
Defaults, Preferences, and Edit Behaviors .....	206	Plan Footprint Specification Dialog .....	340
Selecting Objects .....	210	<b>Walls, Railings, and Fencing .....</b>	<b>342</b>
Selecting Multiple Objects .....	213	Wall, Railing, and Fencing Defaults .....	343
Editing Line-Based Objects .....	216	Wall Tools .....	347
Editing Arc-Based Objects .....	219	Railing and Deck Tools .....	349
Editing Open Polyline-Based Objects .....	224	Fencing Tools .....	351
Editing Closed Polyline-Based Objects .....	228	Exterior and Interior Walls .....	351
Editing Box-Based Objects .....	232	Foundation Walls .....	352
Editing Spline-Based Objects .....	235	Pony Walls .....	354
Editing Circles, Ovals and Ellipses .....	239	Room Dividers and Invisible Walls .....	355
Editing Multiple Objects .....	242	Polygon Shaped Rooms and Decks .....	356
Moving Objects .....	243	Wall Hatching .....	357
Aligning Objects .....	246	Creating Walls .....	357
Resizing Objects .....	253	Connecting Walls .....	361
Reshaping Objects .....	254	Displaying Walls .....	363
Rotating Objects .....	259	Measuring Walls .....	366
Reflecting Objects .....	261	Editing Walls .....	368
Converting Objects .....	262	Edit Handles for Walls .....	372
Transform/Replicate Object Dialog .....	266	Editing Straight/Curved Wall Combinations .....	374
Edit Area Tools .....	269	Aligning Walls .....	375
Stretch CAD .....	271	Roof Directives in Walls .....	378
Trim and Extend .....	272	Attic Walls .....	380
Union, Intersection, and Subtraction .....	274	Stepped and Raked Walls .....	381
Eyedropper and Painter Tools .....	277	Double Walls .....	382
Style Palettes .....	279	CAD to Walls .....	383
Matching Properties .....	282	Wall Type Definitions .....	384
Deleting Objects .....	284	Wall Type Definitions Dialog .....	387
Delete Objects Dialog .....	285	Exporting and Importing Wall Types .....	391
Undo and Redo .....	289	Wall Specification Dialog .....	392
<b>CAD Objects .....</b>	<b>290</b>	Railing and Fencing Specification Dialogs .....	406
CAD Defaults and Preferences .....	291	Wall Hatching Specification Dialog .....	411
The CAD Drawing Tools .....	295	Wall Schedules .....	411
Point Tools .....	296	<b>Rooms .....</b>	<b>412</b>
Line Tools .....	300	Room Definition .....	413
Line Specification Dialog .....	304	Floor and Room Defaults .....	413
Drawing Arcs - Arc Creation Modes .....	307	Room Types and Functions .....	415
Arc Tools .....	309	Displaying Rooms .....	417
Arc Specification Dialog .....	311	Selecting Rooms .....	418
Circle Tools .....	314	Editing Rooms .....	419
Circle/Oval/Ellipse Specification Dialog .....	315	Room Labels .....	422
Polylines .....	316	Decks .....	425
Polyline Specification Dialog .....	317	Floor and Ceiling Heights .....	426
Box Tools .....	319	Floor and Ceiling Platforms .....	428
Box Specification Dialog .....	320	Tray and Coffered Ceilings .....	430
Revision Clouds .....	321	Tray Ceiling Specification Dialog .....	431
Revision Cloud Specification Dialog .....	322	Special Ceilings .....	434
Splines .....	324	Room Moldings .....	436
Displaying CAD Objects .....	325	Room Polylines .....	436
Arrowheads .....	327	Room Specification Dialog .....	437

Room Finish Schedules .....	447	Displaying Windows .....	586
<b>Dimensions</b> .....	<b>448</b>	Editing Windows .....	588
Compatibility With Previous Versions .....	449	Custom Muntins .....	590
Dimension Preferences and Defaults .....	449	Window Specification Dialog .....	591
Dimension Defaults Dialog .....	451	Bay, Box, and Bow Windows .....	608
Auto Story Pole Dimension Defaults Dialog .....	464	Bay, Box, Bow Windows and Roofs .....	610
Temporary Dimension Defaults Dialog .....	467	Bay/Box and Bow Window Specification Dialogs .....	613
The Manually Drawn Dimension Tools .....	469	<b>Cabinets</b> .....	<b>617</b>
The Automatic Dimension Tools .....	472	Cabinet Defaults .....	618
Displaying Dimension Lines .....	474	The Cabinet Tools .....	621
Selecting Dimension Lines .....	475	Cabinet Fillers .....	624
Editing Dimension Lines .....	476	Placing Cabinets and Fillers .....	625
Editing Extension Lines .....	478	Countertops .....	627
Add Additional Text .....	482	Displaying Cabinets .....	628
Moving Objects Using Dimensions .....	483	Cabinet Labels .....	630
Dimension Line Specification Dialog .....	485	Cabinet Construction .....	633
<b>Text, Callouts, and Markers</b> .....	<b>493</b>	Editing Cabinets .....	634
Text Defaults and Preferences .....	494	Editing Cabinet Styles .....	636
Fonts and Alphabets .....	495	Special Cabinets .....	639
The Text Tools .....	497	Cabinet Specification Dialog .....	643
Creating Text Objects .....	497	Cabinet Shelf Specification Dialog .....	658
Displaying Text Objects .....	499	Hardware Size/Orientation Dialog .....	659
Rich Text Specification Dialog .....	500	Shelf/Partition Specification Dialog .....	660
Text Specification Dialog .....	506	Custom Countertop Specification Dialog .....	662
Editing Text .....	510	<b>Electrical</b> .....	<b>666</b>
Copying and Pasting Text .....	514	Electrical Defaults .....	667
Find/Replace Text and Spell Check .....	516	The Electrical Tools .....	668
Text Arrows .....	519	Placing Electrical Objects .....	670
Callouts .....	521	Auto Place Outlets .....	671
Linked Callouts .....	524	Creating Wiring Schematics .....	671
Callout Specification Dialog .....	526	Electrical Library Content .....	672
Markers .....	529	Displaying Electrical Objects .....	673
Marker Specification Dialog .....	531	Editing Electrical Objects .....	674
Notes, Note Types, and Note Schedules .....	533	Light Data Panel .....	675
Note Specification Dialog .....	535	Rope Light Specification Dialog .....	678
Note/Callout Panel .....	536	<b>Schedules and Object Labels</b> .....	<b>681</b>
Text Styles .....	538	Schedule Defaults .....	682
Text Macros .....	540	The Schedule Tools .....	682
<b>Doors</b> .....	<b>543</b>	Create Schedule from Room .....	683
Door Defaults .....	544	Schedule Categories .....	684
Door Tools .....	545	Editing Schedules .....	685
Displaying Doors .....	548	Schedule Numbering .....	688
Editing Doors .....	551	Columns to Include .....	689
Changing Door Swings .....	553	Custom Object Fields .....	690
Special Doors .....	556	Find Object in Plan .....	691
Door Specification Dialog .....	558	Working with Multiple Schedules .....	691
<b>Windows</b> .....	<b>576</b>	Schedule Specification Dialog .....	692
Window Defaults .....	577	Object Labels .....	699
Window Tools .....	577	Label Panel .....	700
Special Windows .....	579	Schedule Panel .....	704
Grouped Windows .....	582	<b>Foundations</b> .....	<b>705</b>
Mulled Units .....	583	Foundation Defaults .....	706
Window Levels .....	585	Foundation Defaults Dialog .....	706

Building a Foundation .....	710	Build Roof Dialog .....	797
Displaying Foundations .....	711	Roof Planes .....	804
Editing Foundations .....	713	Displaying Roofs .....	806
Deleting Foundations .....	716	Editing Roof and Ceiling Planes .....	808
Foundations and Rooms .....	716	Connecting Roof and Ceiling Planes .....	811
Foundations and the Terrain .....	717	Roof Plane Specification Dialog .....	814
The Slab Tools .....	719	Roof Baseline Polylines .....	819
Editing Slabs .....	720	Roof Baseline Specification Dialog .....	821
Slab Specification Dialog .....	720	Roof and Ceiling Framing .....	822
Editing Piers and Pads .....	722	Curved Roof Planes .....	823
Pier/Pad Specification Dialog .....	723	Ceiling Planes .....	826
Fireplaces .....	724	Ceiling Plane Specification Dialog .....	828
Fireplace Specification Dialog .....	726	Gable/Roof Lines .....	830
Library Fireplaces .....	728	Gable Line Specification Dialog .....	833
Chimneys .....	728	Skylights and Roof Holes .....	834
<b>Multiple Floors .....</b>	<b>730</b>	Skylight/Roof Hole Specification Dialog .....	835
Floor Defaults Dialog .....	731	Dormers and Crickets .....	838
Floor Tools .....	731	Editing Auto Dormers .....	840
Adding Floors .....	732	Dormer Specification Dialog .....	841
Displaying Floor Levels .....	734	Roof Returns and Other Details .....	844
Exchanging Floors .....	735	Roof Pitches in Degrees .....	849
Copying Floors .....	735	<b>Framing .....</b>	<b>850</b>
Deleting Floors .....	735	Framing Defaults .....	851
Rebuilding Walls, Floors and Ceilings .....	735	Manual vs. Automatic Framing .....	854
Split Levels .....	736	Framing Tools .....	856
The Current Floor .....	737	Build Framing Dialog .....	860
The Attic Floor .....	738	Framing Reference Markers .....	875
The Reference Display .....	738	Joist Direction Lines .....	876
<b>Stairs, Ramps, and Landings .....</b>	<b>742</b>	Joist Direction Specification Dialog .....	877
Stair and Ramp Defaults .....	743	Bearing Lines .....	878
The Stair Tools .....	743	Displaying Framing .....	879
Anatomy of a Staircase .....	745	Editing Framing .....	882
Drawing Stairs and Ramps .....	746	Keeping Framing Current .....	884
L- and U-Shaped Stairs .....	747	Build Framing for Selected Object(s) .....	885
Displaying Stairs, Ramps, and Landings .....	749	Framing and the Materials List .....	886
Editing Stairs and Ramps .....	750	Framing Specification Dialog .....	887
Stair and Ramp Sections and Subsections .....	752	Export to EasyFrame .....	890
Landings .....	755	<b>Trusses .....</b>	<b>894</b>
Maintaining Tread Depth .....	756	Truss Defaults .....	895
Flared Stairs and Curved Treads .....	757	Floor and Ceiling Trusses .....	895
Starter Treads .....	761	Roof Trusses .....	895
Winders .....	762	Drawing Trusses .....	896
Wrapped Stairs .....	763	Displaying Trusses .....	897
Other Special Railings and Stairs .....	765	Editing Trusses .....	898
Creating a Stairwell .....	769	Editing Truss Envelopes .....	900
Rooms Below Staircases .....	770	Truss Details .....	901
Staircase Specification Dialog .....	771	Truss Labels .....	902
Ramp Specification Dialog .....	784	Mixing Trusses with Stick Framing .....	902
Stair Landing Specification Dialog .....	787	Truss Bases .....	903
<b>Roofs .....</b>	<b>791</b>	Truss Base Specification Dialog .....	907
Automatic vs. Manual Roofs .....	792	Hip Trusses .....	908
Roof Defaults .....	792	Special Roof Trusses .....	909
The Roof Tools .....	793	Roof Truss Specification Dialog .....	912
Automatic Roofs .....	795	Floor/Ceiling Truss Specification Dialog .....	916
		Framing and Truss Schedules .....	919

<b>Trim and Moldings</b> .....	<b>920</b>
Trim and Molding Defaults .....	921
Corner Boards .....	921
Corner Board Specification Dialog .....	922
Quoins .....	923
Quoin Specification Dialog .....	923
Editing Corner Boards and Quoins .....	925
Moldings and Millwork .....	926
Moldings // Profiles / Rails / Panels .....	927
Molding Specification Dialog .....	931
Molding Profiles .....	932
Symbol Moldings .....	934
Molding Polylines .....	935
Displaying Molding Polylines .....	937
Editing Molding Polylines .....	937
Molding Polyline Specification Dialog .....	938
3D Molding Polyline Specification Dialog .....	939
Frieze Moldings .....	943
<b>The Library</b> .....	<b>945</b>
The Library Browser .....	946
Searching and Filtering the Library .....	953
Find in Library .....	960
Library Content .....	961
Downloading Library Content .....	963
Importing Library Catalogs .....	964
Adding Library Content .....	965
Organizing the Library .....	967
Editing Library Objects .....	970
Exporting Library Catalogs .....	972
Placing Library Objects .....	972
Select Library Object Dialog .....	974
Place Library Object Button .....	975
Replace From Library .....	976
<b>Symbol Objects</b> .....	<b>978</b>
Displaying Symbol Objects .....	979
Editing Symbol Objects .....	980
Symbol Object Specification Dialogs .....	986
Importing 3D Symbols .....	998
3D Data Import Requirements .....	999
3D Symbols and Materials .....	1000
Get Last Symbol .....	1002
Convert to Symbol .....	1002
Symbol Categories .....	1003
Exporting a 3D Model .....	1004
<b>Architectural Blocks</b> .....	<b>1007</b>
Architectural vs CAD Blocks .....	1008
Creating Architectural Blocks .....	1008
Displaying Architectural Blocks .....	1008
Editing Architectural Blocks .....	1009
Architectural Block Specification Dialog .....	1010
Architectural Blocks, Sub-Objects, and Components .....	1012
<b>Other Objects</b> .....	<b>1014</b>

Primitive Tools .....	1015
Creating Primitives .....	1015
Editing Primitives and 3D Solids .....	1017
Creating Complex Structures with Primitives .....	1021
3D Solid Specification Dialog .....	1022
Sphere Specification Dialog .....	1025
Cylinder Specification Dialog .....	1026
Cone Specification Dialog .....	1028
Pyramid Specification Dialog .....	1030
General Shapes .....	1033
Soffits .....	1033
Soffit Specification Dialog .....	1034
Floor and Wall Material Regions .....	1037
Material Region Specification Dialog .....	1038
Material Layers Definition Dialogs .....	1040
Distributed Objects .....	1042
Distribution Region/Path Specification Dialogs .....	1043
<b>Materials</b> .....	<b>1049</b>
About Materials .....	1050
Material Defaults .....	1051
Material Painter Tools .....	1052
Materials Panel .....	1055
Select Material/Library Object Dialog .....	1056
Editing Materials .....	1058
Creating Materials .....	1060
Mapping Patterns and Textures .....	1062
Materials and the Materials List .....	1063
Managing Plan Materials .....	1064
Define Material Dialog .....	1066
Pattern from Texture Dialog .....	1077
<b>3D Views</b> .....	<b>1079</b>
Types of 3D Views .....	1080
3D View Defaults and Preferences .....	1080
Camera Defaults Dialogs .....	1081
3D View Defaults Dialog .....	1083
3D View Tools .....	1084
Creating Camera Views .....	1086
Creating Overviews .....	1087
Cross Section/Elevation Views .....	1089
Clipped Section Views .....	1091
Detailing Cross Section/Elevation Views .....	1094
Displaying 3D Views .....	1097
Navigating in Camera Views .....	1100
Editing 3D Views .....	1105
Cross Section Slider .....	1108
Working in 3D .....	1109
Virtual Reality .....	1110
Saving and Printing 3D Views .....	1115
Camera Specification Dialogs .....	1116
Cross Section/Elevation Specification Dialogs .....	1124
<b>3D Rendering</b> .....	<b>1131</b>
Rendering Tips .....	1132
Lighting .....	1135
Light Types .....	1137

Displaying Lights .....	1138	Terrain Modifier Tools .....	1251
Light Sets .....	1139	Terrain Features .....	1252
Light Specification Dialog .....	1142	Terrain Wall and Curb Tools .....	1254
Sun Angles and Shadows .....	1143	Terrain Objects in the Library .....	1256
Sun Angle Specification Dialog .....	1145	Displaying Terrain .....	1256
Adjust Sunlight Dialog .....	1148	Editing Terrain Objects .....	1257
Rendering Techniques .....	1150	Terrain Specification Dialog .....	1258
Rendering Technique Options .....	1153	Elevation Point Specification Dialog .....	1263
<b>CPU Ray Tracing .....</b>	<b>1167</b>	Elevation Line/Region Specification Dialog .....	1264
CPU Ray Trace Views .....	1168	Flat Region Specification Dialog .....	1265
CPU Ray Trace Configurations .....	1169	Hill / Valley Specification Dialog .....	1266
CPU Ray Trace Options .....	1171	Raised / Lowered Region Specification Dialog .....	1268
CPU Ray Trace Assistant .....	1176	Terrain Feature Specification Dialogs .....	1268
Adjusting Ray Trace Properties and Effects .....	1179	Grass Region Specification Dialog .....	1270
CPU Ray Tracing Tips .....	1180	Terrain Break Specification Dialog .....	1272
<b>Pictures, Images, and Walkthroughs .....</b>	<b>1184</b>	Terrain Path Specification Dialog .....	1273
Picture Files vs Pictures and Image Objects .....	1185	Importing Elevation Data .....	1276
Images .....	1185	Import Terrain Assistant .....	1277
Displaying Images .....	1186	Import GPS Data Assistant .....	1280
Editing Images .....	1187	Importing DWG/DXF Elevation Data .....	1282
Image Specification Dialog .....	1188	Converting CAD Objects to Terrain Data .....	1282
Pictures .....	1191	<b>Roads, Driveways, and Sidewalks .....</b>	<b>1283</b>
Picture File Box Specification Dialog .....	1193	Road and Sidewalk Defaults .....	1284
Metafiles .....	1195	Road, Driveway, and Sidewalk Tools .....	1284
Metafile Box Specification Dialog .....	1196	Displaying Road Objects .....	1287
PDF Files .....	1198	Editing Road Objects .....	1288
PDF Box Specification Dialog .....	1199	Road Specification Dialog .....	1289
Displaying Pictures, Metafiles, and PDF Boxes .....	1200	Road Marking Specification Dialog .....	1291
Editing Pictures, Metafiles, and PDF Boxes .....	1201	<b>Plants and Sprinklers .....</b>	<b>1293</b>
Creating Screen Captures .....	1203	Plant Tools .....	1294
3D Backdrops .....	1204	Plant Chooser Dialog .....	1295
Backdrop Specification Dialog .....	1205	Hardiness Zones .....	1297
Walkthrough Paths .....	1207	Plant Image Specification Dialog .....	1297
Walkthrough Path Specification Dialog .....	1210	Plant Specification Dialog .....	1301
Walkthrough Previews .....	1212	Sprinkler Tools .....	1301
Recording a Walkthrough .....	1215	Sprinkler Specification Dialogs .....	1302
Creating VRML Files .....	1219	<b>Materials Lists .....</b>	<b>1303</b>
<b>Importing and Exporting .....</b>	<b>1222</b>	The Materials List Tools .....	1304
Chief Architect Account Login .....	1223	Creating an Accurate Materials List .....	1305
Export Chief Architect 3D Viewer File .....	1223	Structural Member Reporting .....	1306
Import Room Planner File .....	1226	Organizing Materials Lists .....	1310
DXF vs DWG File Formats .....	1226	Materials List Specification Dialog .....	1312
Importing 2D Drawings .....	1226	Materials List Columns .....	1317
Import Drawing Assistant .....	1228	Editing Materials Lists .....	1319
Exporting 2D DXF/DWG Files .....	1235	Materials List Formulas .....	1320
Additional 2D Export Information .....	1237	Materials List Polylines .....	1322
Export 360 Panorama .....	1238	Materials List Polyline Specification Dialog .....	1322
Export Thermal Envelope Data .....	1240	Saving and Managing Materials Lists .....	1324
Export to REScheck .....	1240	Printing and Exporting the Materials List .....	1325
<b>Terrain .....</b>	<b>1243</b>	The Master List .....	1327
Terrain Toolbar Configuration .....	1244	Object Components .....	1329
Terrain Perimeter .....	1244	Object Information Panel .....	1331
Elevation Data Tools .....	1246	<b>Layout .....</b>	<b>1333</b>



Layout Preferences and Defaults .....	1334
The Layout Tools .....	1335
Creating a Layout File .....	1336
CAD and Text in Layout .....	1337
Pictures, Metafiles, and PDFs in Layout .....	1338
Sending Views to Layout .....	1338
Keeping Layout Views Current .....	1341
Displaying Layout Views .....	1344
Editing Layout Views .....	1345
Editing Layout Lines .....	1348
Layout Box Specification Dialog .....	1349
Opening Layout Views .....	1353
Managing Layout Links .....	1353
Layout Page Management .....	1355
Layout Page Information .....	1358
Layout Page and Revision Tables .....	1361
Printing Layout Files .....	1361
Exporting Layout Files .....	1362

**Printing and Plotting .....** **1363**

Introduction to Printing .....	1364
Printers and Plotters .....	1364
Printing Defaults .....	1365
The Printing Tools .....	1366
Drawing Sheet Setup Dialog .....	1367
Print Preview .....	1371
Printing to Scale .....	1372
Printing Across Multiple Pages .....	1374
Printing to a PDF File .....	1374
Line Weights .....	1374
Watermarks .....	1377
Print View Dialog .....	1380
Print Image Dialog .....	1383

**Ruby in Chief Architect .....** **1386**

Creating User Defined Macros .....	1387
Working with NVPublishers .....	1387
Working with Name-Value Pairs .....	1389
Macros and Context .....	1390
Measurement and NumberFormatter Classes .....	1393
Text Macro Management Dialog .....	1396
The Ruby Console .....	1399
Viewing the Interactive Tutorial .....	1401
Migrating Legacy Ruby Code .....	1401

**Resources and Support .....** **1403**

Learning and Inspiration .....	1404
Training Services .....	1405
Contacting Technical Support .....	1405
Error Messages .....	1406
Program Paths Dialog .....	1407

**What's New in Chief Architect X15 .....** **1408**

Getting Started Checklist .....	1409
Migrating Legacy Content .....	1410
Migrating Legacy Settings .....	1410
Migrating Legacy Templates .....	1411

Considerations for Legacy Files .....	1411
New and Improved Features by Chapter .....	1419
<b>Index .....</b>	<b>1426</b>

# Program Overview

# Chapter 1

Chief Architect is specifically designed for the residential and light commercial design professional. It allows you to easily and efficiently produce 3D models and construction documents for your projects. We thank you for choosing Chief Architect and wish you the best in your design work.

## TOPICS

<b>Dashboard</b> .....	<b>11</b>
<b>The Chief Architect Premier Environment</b> .....	<b>12</b>
<b>Using Input Devices</b> .....	<b>14</b>
<b>View and Side Windows</b> .....	<b>17</b>
<b>Menus, Toolbars, and Hotkeys</b> .....	<b>18</b>
<b>Dialogs</b> .....	<b>19</b>
<b>Edit Handles</b> .....	<b>23</b>
<b>The Status Bar</b> .....	<b>24</b>
<b>Message Boxes</b> .....	<b>25</b>
<b>Preferences and Default Settings</b> .....	<b>26</b>
<b>Drawing a Plan</b> .....	<b>27</b>
<b>Viewing Your Plan</b> .....	<b>29</b>
<b>Sharing Your Files with Clients</b> .....	<b>31</b>
<b>Getting Help</b> .....	<b>31</b>
<b>About Chief Architect</b> .....	<b>32</b>
<b>Chief Architect Trial Software</b> .....	<b>32</b>

## Dashboard





 When Chief Architect opens, the Dashboard window displays, allowing you to choose how you want to begin working in the program or access useful resources. The Dashboard can also be opened at any time by selecting **File > Dashboard**.

You can control whether the Dashboard automatically opens and closes in the Preferences dialog. See [General Panel on page 102](#).



### 1 New/Open File

Select a **File** command to open a .plan or .layout file.

- Click **New Plan**  or **New Layout**  to open a new, blank file. See [Creating a New Plan or Layout on page 38](#).
- Click **New from Template**  to open a new, blank plan based on a template that you select. See [Template Files on page 87](#).
- Choose **Open Plan**  or **Open Layout**  to work on an existing or layout file. See [Opening and Importing Files on page 44](#).

## 2 Recent Files

The full pathnames of the most recently opened files are listed here. Click on a name to open the file. You set the number of files in this list in the Preferences dialog. See *General Panel on page 102*.

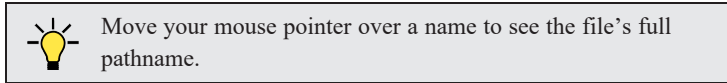

## 3 Getting Started & Resources

A selection of useful online **Getting Started** options and **Resources** are available here. Click on an option to launch your default internet browser to [chiefarchitect.com](http://chiefarchitect.com).

- Click **Getting Started** to visit the Getting Started page on our website with links to a variety of resources to help you begin using the program.
- Click **Training Videos** to access a searchable collection of videos focused on specific topics.
- Click **Download Catalogs** to visit our 3D Library of downloadable bonus and manufacturer library catalogs. See *Library Content on page 961*.

## 4 Announcements

When an internet connection is available, the **Announcements** section displays updated messages and news from Chief Architect.

## 5 My Account

Click **My Account** to launch your default internet browser to the My Account page on our website. If you are not currently logged in, you will instead go to the Login page.

## 6 Build & Product Key

Your software version's **Build** number and the first five characters of your **Product Key** display here for reference.

---

# The Chief Architect Premier Environment

Chief Architect is designed to be intuitive and efficient.

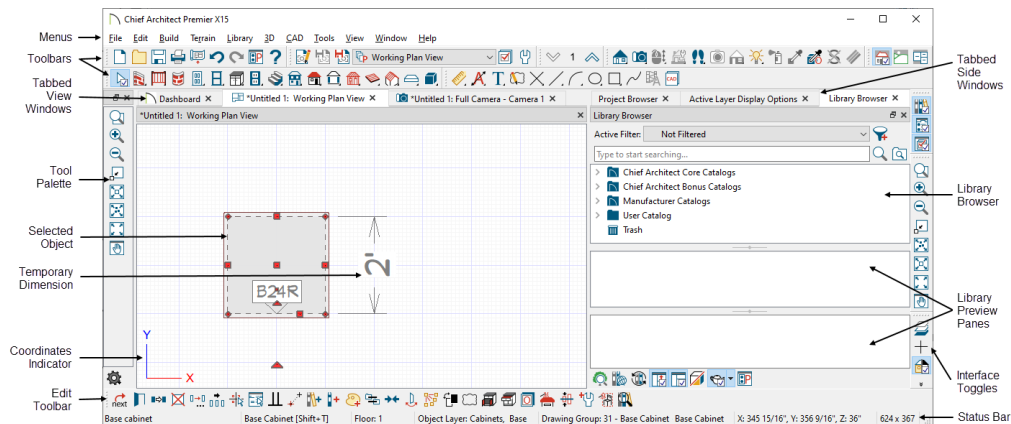

### 3D DRAFTING

In Chief Architect, the drawing area is laid out on a Cartesian grid: a three dimensional coordinate system described using the X, Y, and Z axes. A Coordinate System Indicator displays at the bottom left corner of most views, and the current position of your mouse pointer displays in the Status Bar at the bottom of the program window. See *Coordinate System Indicators on page 145*.

Architectural objects take up space in all three dimensions and their height, width and depth can be specified in U.S. or metric units. In addition, the location of objects can be precisely defined using coordinates, again specified in U.S. or metric units. See *Moving Objects Using Dimensions on page 483*.

CAD objects such as lines and arcs take up space in two dimensions in the current view. Their dimensions can also be specified in U.S. or metric units and their locations precisely defined using coordinates.

Objects can be rotated relative to the Cartesian grid system, as well. When the program presents the option to rotate to an Absolute Angle, this angle will be measured relative to an imaginary horizontal line drawn in floor plan view from the origin in the positive X direction.

### EASY ACCESS TO TOOLS

You can access Chief Architect's features in various ways using the mouse and keyboard.

- Convenient toolbar buttons allow fast access to frequently-used tools and let you customize the interface.
- Menus provide access to most tools and settings.
- Keyboard shortcuts are available for most tools and can be customized.
- Contextual menus display with a right-click of the mouse.
- *The Status Bar on page 24* at the bottom of the screen provides tool descriptions and other information about the current task.

### OBJECT-BASED DESIGN

Chief Architect's parametric, object-based design technology means you place and edit objects, rather than work with the many individual lines or surfaces used to represent them.

You can quickly select and edit the location, size, shape, style and other properties of objects as well as change the materials applied to their surfaces.

Use Chief Architect's editing capabilities to make the objects you place in a plan match the objects they represent in real life. For example, you can set up your windows and doors to match those available from your supplier.

### INTERFACE TOGGLES

A number of useful drawing and editing behaviors, as well as the display of important elements in the interface, can be easily enabled and disabled using the menus and toolbars.

- Object Snaps, Angle Snaps, and Grid Snaps can be toggled on or off as needed. Individual Object Snaps and Extension Snaps can be toggled as well. See *Snap Behaviors on page 159*.
- Display Elements like Print Preview, Show Line Weights, and the Reference Display can be turned on when needed and then toggled off.
- Special Edit Behaviors can be enabled for particular tasks, then replaced by the Default Behavior. See *Defaults, Preferences, and Edit Behaviors on page 206*.

When a setting is turned on, or a tool is selected, its toolbar icon will be shaded and a small check is displayed at its lower right corner. In Windows its menu icon will appear the same, but in Mac OS only a large check will be displayed to the left of the icon.

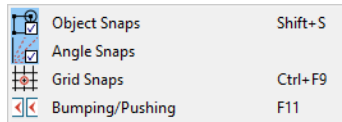

Menu in Windows



Menu in Mac OS

Many of these interface elements are global Preferences while others are file-specific default settings. See [Default Settings vs Preferences on page 77](#).

---

## Using Input Devices

You can interact with Chief Architect using a variety of input devices.

### KEYBOARD

A keyboard is necessary for entering text and size values. See [Dialogs on page 19](#).

Your keyboard can also be used to navigate the dialog panels, as well as navigate the program menus. Many commands can also be invoked using keyboard hotkeys. See [Menus, Toolbars, and Hotkeys on page 18](#).

In addition to the keyboard, a mouse or other device that can move a pointer is necessary in order to draw, select, and edit objects in your drawings.

### THREE BUTTON MICE

#### *Left Button*



The **left button** is the primary button used in Chief Architect. Unless specified otherwise, Chief Architect documentation refers to the left mouse button.

Many objects, such as doors and cabinets, are created by clicking the left mouse button. Others, such as walls, stairs and dimension lines, are created by dragging the pointer from one end of the object to the other.

Note: If you are left-handed and have re-programmed your mouse, reverse the instructions for left and right buttons in this manual.

#### *Right Button*



The **right button** has several uses:

- Right-click to select any object. If, for example, the **Straight Exterior Wall**  tool is active, the left mouse button only allows you to select walls. You can, however, select other types of objects such as cabinets with the right mouse button.
- Use the right mouse button to temporarily switch to the Alternate edit behavior. See [Defaults, Preferences, and Edit Behaviors on page 206](#).
- You can also use the right mouse button to open a context sensitive menu with additional editing commands. See [Contextual Menus on page 19](#).

### **Middle Button**



The **middle button** can be used to pan in most view types or to temporarily use the Move edit behavior. To close a tabbed view window, click on its tab using the middle mouse button. You can also program it to work as a double-click.

If your mouse does not have a middle mouse button, in the Mac version of Chief Architect you can use the left button and the Command key to achieve the same results.

### **Mouse Wheel**



The **mouse wheel** can be used to zoom in and out in most view types. See [Zoom Tools on page 153](#).

The Back, or X1, button on a 5-button mouse can be used to temporarily enable the Concentric edit behavior. See the documentation for your mouse.

The Forward, or X2, button on a 5-button mouse can be used to temporarily enable the Resize edit behavior. See the documentation for your mouse.

## **3D MICE**

3Dconnexion®'s 3D mice can be used to navigate in Chief Architect. For information about navigating in camera views and overviews, see [3Dconnexion® 3D Mice on page 1101](#).

## **TRACKPADS**

In addition to the standard trackpad gestures on your system, in Chief Architect you can pinch to zoom.

In macOS™, you can Option + click to pan. Panning with a trackpad is not supported in the Windows version of the software, however.

## **TOUCH SCREENS**

Standard one-finger touch screen gestures are supported in both the Windows and Mac versions of the software. In the Windows version, touching with a second finger to cancel an action is also supported, as are two-finger pan and two-finger pinch to zoom.

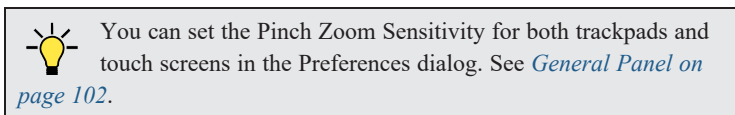

## **GAMEPADS**



In the Windows version of Chief Architect, gamepads can be used to navigate in camera views, overviews, as well as elevation views. See [Gamepads on page 1101](#).

## CROSSHAIRS











✚ Crosshairs help you position the pointer relative to objects in a view while drawing and editing. They can be set to display in Plan and Cross Section/Elevation views and CAD Details, and in Perspective and Orthographic camera views. Select **View > Crosshairs** to toggle crosshairs on or off in the current view type.

You can customize the Crosshairs' appearance and control their display in different view types in the Preferences dialog. See *Edit Panel on page 115*.

## POINTER ICONS

The appearance of the pointer or cursor in Chief Architect will vary, depending on which tool is active. For example, when the **Select Objects**  tool is active, it will look like a white arrow, and when a **Cabinet Tool**  is active, it will look like a base cabinet with a small cross.

In addition, one or more additional icons may follow the pointer if a recommended setting is not in use or if a problematic condition exists in the file:

Icon	Reason
	<b>Angle Snaps</b> has been disabled. See <i>Angle Snaps on page 162</i> .
<b>Alt</b>	The <b>Alternate</b> Edit Behavior has been selected. See <i>Alternate on page 207</i> .
	The <b>Move</b> Edit Behavior has been selected. See <i>Move on page 207</i> .
	The <b>Resize</b> Edit Behavior has been selected. See <i>Resize on page 208</i> .
	The <b>Concentric</b> Edit Behavior has been selected. See <i>Concentric on page 208</i> .
	The <b>Fillet</b> Edit Behavior has been selected. See <i>Fillet on page 209</i> .
	<b>Connect CAD Segments</b> has been disabled. See <i>Connect CAD Segments on page 210</i> .
	The <b>Rotate/Resize About Current Point</b> Edit Behavior has been selected. See <i>Rotate/Resize About Current Point on page 210</i>
	<b>Auto Rebuild Terrain</b> has been disabled. See <i>Auto Rebuild Terrain on page 1246</i>
	<b>Rebuild Walls, Floor and Ceilings</b> has been disabled. See <i>Rebuilding Walls, Floors and Ceilings on page 735</i>
	A bad wall connection has been detected. See <i>Fix Wall Connections on page 362</i>
	An irregular wall angle has been detected. See <i>Wall Angles on page 358</i>



Icon	Reason
	A reversed wall has been detected. See <i>Reverse Layers on page 369</i>

You can turn off the display of these informative pointer icons in the Preferences dialog if you wish. See *Behaviors Panel on page 118*.

---

## View and Side Windows

Chief Architect Premier's main program window has a number of important features that let you interact with the program, such as toolbars and menus. It also features two different kinds of windows: view windows and side windows.

### VIEW WINDOWS

View windows are sometimes referred to as “the drawing area” because most of them are windows in which you can draw or place architectural and/or CAD objects. There are a number of different types of view windows in Chief Architect:

- Plan views
- Camera views and overviews
- Cross section/elevation views
- CPU Ray Trace views
- CAD Details
- Materials Lists
- Layout

View windows can be navigated by panning and zooming. You can also enable scrollbars on their right side and bottom. Select **View> Scrollbars**  to toggle their display. See *View Tools on page 152*.

Although only one view window can be active at any given time, there is no limit to the number of view windows that can be open. View windows can be tiled or tabbed, and you can navigate between them in a number of different ways. See *Window and View Tools on page 143*.

You can also tear a view window out of the main program window. This creates a second, separate program window complete with toolbars and menus. Individual view windows can be torn out and transferred between program windows.

### SIDE WINDOWS

Side windows provide access to a variety of tools, content, and information that helps you organize and add detail your drawings.

Side windows are so-named because they are typically docked to either the left or right side of the program window - although, they can also be docked to the top or bottom, or undocked entirely. There are several different side windows in Chief Architect:

- *Child Tool Palette on page 129*
- *The Library Browser on page 946*
- *Project Browser on page 58*
- *Active Layer Display Options on page 185*
- *Walkthrough Previews on page 1212*

Each of these side windows can be opened via the **View** menu or by clicking the toolbar button associated with it. Similarly, each can be closed by clicking the **Close** button in its title bar or tab, via the **View** menu, or by clicking its toolbar button. See [View Tools on page 152](#).

Side windows can be resized by clicking and dragging an undocked edge. To undock a side window, either drag its title bar out into the drawing area or click the Undock button on its title bar. To dock a side window, drag its title bar to any side of the program window. You can also double-click on its title bar to return it to its last docked location.

Two or more side windows can be docked together to form a shared side window, and can be tiled and/or tabbed within that shared window. To create a shared side window, begin by docking a side window to a side of the main program window, then:

- To create tabbed side windows, drag a second side window over the first. When the docked window becomes highlighted, release the mouse button.
- To create tiled side windows, drag a second side window over the first. When the docked window becomes highlighted, slowly drag the mouse towards one of its sides. When a highlighted space is created along that side, release the mouse button.

To prevent a side window from docking while you are moving it, hold down the Ctrl key while dragging it. You can also choose to disable **Side Window Drag Docking** in the Preferences dialog, and you can enable or disable **Top/Bottom Docking** for each side window, as well. See [Appearance Panel on page 95](#).

Side windows can also be set to their initial states in the Preferences dialog. See [Reset Options Panel on page 125](#).

---

## Menus, Toolbars, and Hotkeys

Chief Architect's drawing, editing, and view tools can be accessed via menus, toolbar buttons, and keyboard hotkeys.

### PROGRAM MENUS

Chief Architect's program menus are located below the title bar in the program window and can be used to access nearly all tools in the program. Click on a menu name to expand it, then click on a menu item to either activate that tool or access the item's submenu. Items with a submenu have an arrow to the right of the name.

In the Chief Architect documentation, menu paths are written in this format: **Tools> Floor/Reference Display> Up One Floor** .

The menus can be accessed using the keyboard:

- Press the Alt key once to enable this functionality - one letter in each menu will become underlined.
- Press the key associated with one of these underlined letters to expand its menu - one letter in each menu item's name will be underlined. Press the key associated with one of these letters to activate that tool or access the item's submenu.
- Press the Esc key to undo your last selection, or click with the mouse to exit out of this functionality.

Menu items with an icon to their left have a toolbar button associated with them. In addition, many tools can also be activated using keyboard hotkeys. If a menu item has a default hotkey, it will display to the right of the item's name.

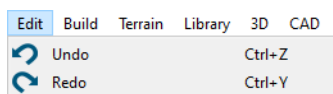

Edit menu items with button icons to the left and hotkeys to the right

## TOOLBARS AND HOTKEYS

Chief Architect installs with a set of toolbars docked to the margins of the program window. Using these toolbar buttons is a fast and easy way to access many program features. If a tool is active, a small check mark will display at the lower right of its button icon. See [Toolbars and Hotkeys on page 128](#).

The Edit Toolbar is a special toolbar with buttons that can be used to modify a selected object or objects. The buttons on this toolbar vary, depending on the type(s) of object selected, the current view, and how you selected the object; when no object is selected, the Edit Toolbar is blank. See [The Edit Toolbar on page 130](#).

You can move the toolbars, customize them by adding or removing buttons, or create your own toolbars from scratch. See [Toolbar Customization Dialog on page 134](#).

Many tools also have a keyboard hotkey associated with them. Hotkeys are customizable and can be created for tools that do not have one by default. See [Hotkeys on page 137](#).

## CONTEXTUAL MENUS

Contextual menus are context-sensitive menus that display tools relevant to a selected object or view. To open a contextual menu, right-click on an object, in an empty space in a view window, on a line item in the Library Browser or Project Browser, or in a text field in a dialog box.

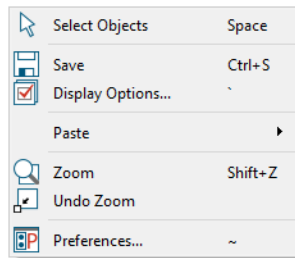

Contextual Menu for Plan Views

The options in an object's contextual menu are usually the same as those on an object's Edit Toolbar. See [The Edit Toolbar on page 130](#).

Contextual Menu for a selected

Contextual menus can be enabled or disabled in the Preferences dialog. When contextual menus are disabled, right-clicks perform generic object selection, much like when the **Select Objects**  tool is active. See [Appearance Panel on page 95](#).

---

## Dialogs

Default and preference settings, object specifications, display settings, and many other functions are accessed through dialog boxes.

Note: Some of the dialog box images in the software documentation have been resized smaller than their actual minimum size.

## DIALOG PANELS

Many dialogs have multiple panels, which are listed in a tree list on the left side of the dialog. Click on a panel name in the list to make it active. In Windows, panels can also be navigated using the keyboard. Press:

- **Ctrl + Tab** or **Ctrl + F6** to navigate forward;
- **Ctrl + Shift + Tab** or **Ctrl + Shift + F6** to navigate backward.

When a panel name is actively selected in the list, you can also navigate the tree list using the **Up** and **Down** arrow keys.

By default, dialogs always open to the first panel in the list; if you prefer, you can choose to **Open Dialogs to the Last Panel Visited**. See [General Panel on page 102](#).

## UNITS AND MATH OPERATIONS IN DIALOGS

The units of measurement used in dialogs are determined by your choice of template files. See [Creating a New Plan or Layout on page 38](#).

The number format used in dialogs are set based on your operating system's defaults. See [Region and Language Settings on page 78](#). You can change the number format as well as the angle format in the Dialog Number Style/Angle Style dialog. See [Dialog Number/Angle Style Dialog on page 126](#).

Basic addition, subtraction, multiplication, and division can be performed in the text boxes where numeric values are entered.

Note that settings for angle, pitch, or bearing do not support math, nor do those with spin controls or slider bars.

- To add, type the + character followed by the amount that you wish to add. Spaces are ignored and including a unit of measurement is optional.
- To subtract, type the - character followed by the amount you wish to subtract. As with adding, spaces are ignored and a unit of measurement is optional.
- To multiply, type the \* character followed by the amount you wish to multiply by. Spaces are ignored, and only one of the values being multiplied can have a unit of measurement.
- To divide, type the / character followed by the amount you wish to divide by. To divide, there must be a space before the / - if there is not, the input may be treated as a fraction. The denominator, or value typed after the /, cannot have a unit of measurement.

Math expressions support a single operation only: more than one operation character (+, -, \*, /) at a time is not allowed.

Basic math operations can also be used to move objects using dimensions. See [Moving Objects Using Dimensions on page 483](#).

## ELEVATION REFERENCES

A variety of different architectural objects can be placed at a particular elevation in the 3D drawing space. That elevation can be set relative to a number of different references; the options available may vary depending on the object type:

- **Absolute** is measured from  $Z = 0$ . See [3D Drafting on page 13](#).
- **From Floor** is measured relative to top of the Floor Structure at the object's location. See [Floor and Ceiling Heights on page 426](#).
  - If the object is not in a room, it is measured relative to the default Floor Height for its Floor Level. See [Multiple Floors on page 730](#).
  - If the object is not in a room and is on the same Floor Level as the Terrain, it is instead measured relative to the Terrain.
- **From Finished Floor** is measured relative to the object to the surface of the Floor Finish at the object's location.
  - If the object is not in a room, it is measured in the same manner as From Floor.

- **From Terrain** is measured relative to the object to the surface of the terrain at the object's location. See *Terrain on page 1243*.
  - If no terrain is present, it is measured relative to the default Floor Height for its Floor Level.
- **From Ceiling** is measured relative to the object to the Ceiling surface at the object's location.
  - If the object is not in a room, it is measured relative to the default ceiling height for its Floor Level.
- **From Roof** is measured relative to the object to the Roof surface at the object's location. See *Roofs on page 791*.
  - If the object is not in a room, it is measured relative to the default ceiling height for its Floor Level.

## DIALOG SIZE AND POSITION

Dialog boxes can be both moved and resized to suit your needs. By default, the program will remember both the position and size that you specify for a dialog and use it the next time you open it. The size of dialog preview panes can also be changed, and are remembered as well. You can specify whether the program does this always, per session, or never in the Preferences dialog. See *General Panel on page 102*.

- To move a dialog, position your mouse pointer within its title bar and then simply click and drag.
- To resize a dialog, position your mouse pointer on any edge or corner and then click and drag outward or inward. If you drag an edge, only that edge will move; if you drag a corner, the two adjacent edges will move.
- To resize a preview pane, click and drag the vertical grab handle to its left. See *Dialog Panel Splitters on page 22*, below.

When a dialog is resized, some elements such as list boxes and text fields within it may resize in response.

All dialogs have a minimum size limitation but no maximum size. If a dialog opens on a monitor with resolution too low to display its full extents, it will have vertical and/or horizontal scrollbars.

You can reset the default sizes and positions of all dialogs in the Preferences dialog. See *Reset Options Panel on page 125*.

## SPECIFICATION DIALOGS

 Each object in Chief Architect has a unique specification dialog where you can enter size, style and other information specific to the selected object. To access it, select the object and click the **Open Object** edit button.

You can also double-click on an object with the **Select Objects**  tool active to open its specification dialog. See *Selecting Objects on page 210*.

In addition, you can access an active camera view's specification dialog by selecting **3D> Edit Active Camera** . The 3D View tools also have defaults dialogs where you can specify the initial attributes of camera views. See *3D Views on page 1079*.

In addition, you can open the specification dialog for objects associated with a schedule row. See *Open Row Object(s) on page 686*.

Most objects also have a defaults dialog that lets you specify the initial values in the specification dialog. See *Default Settings on page 77*.

You can open the specification dialog for group-selected objects if they are of the same type, such as base cabinets.

- If a particular setting varies among the different objects, its check box will have a solid fill instead of a check mark. Click once to clear the box for all selected objects, or click a second time to place a check mark for all selected objects.
- In some dialogs, if a particular setting varies among the different objects, it will have a “No Change” radio button. Leave this button selected, or choose a different option to apply it to all objects in the selection set.

- If the setting has a text field or drop-down list, it will say “No Change”. Changes made to such a setting can be undone by replacing the value in the text field with the letter N before you click OK.
- In a few cases, such as schedule Columns to Include, the “No Change” attribute cannot be modified.

If you select multiple objects of different types, the **Open Object**  edit button is usually not available. This button may be available if the objects have data in common, but you can only edit the common data.



## DIALOG PREVIEW PANES

Many specification dialogs have a preview pane that shows how changes to settings affect the selected object. This preview updates when you click in a different field or press the **Tab** key on your keyboard.

If you switch to a panel with settings that affect the selected object’s appearance in a certain view, that view will be shown in the preview. For example, if you select the **GENERAL** panel, a 3D view will be shown; but if you select the **FILL STYLE** panel, floor plan view will be shown. When floor plan view is shown, the primary and all secondary layers associated with the object will display. See *Primary and Secondary Layers on page 177*.

When you click in the preview pane, your mouse pointer changes to a four-headed arrow and you can rotate around the object as well as zoom in and out using the mouse scroll wheel. Some objects, notably walls, doors, and windows, have Interior and Exterior labels to indicate which side is visible in the preview. Click the **Fill Window**  button above the preview pane to zoom in or out so that the object fills the extents of the pane, maintaining the current rotation.

In most dialogs, the Standard, Vector View, and Glass House Rendering Techniques can be applied to the preview. See *Rendering Techniques on page 1150*. You can specify whether Standard or Vector View is used by default in the Preferences dialog. See *Appearance Panel on page 95*.

Click the **Color**  button to turn color in the preview off or on. Some objects have additional tools that affect object previews. For example, the Cabinet Specification dialogs have a **Select Cabinet Face Item**  button. Object specific tools like this are discussed in the documentation for that object type.

Note: When multiple objects are selected, their shared specification dialog preview will typically only show one of the objects.

## DIALOG PANEL SPLITTERS

Many dialog panels are divided into up to three sections: a list of panels on the left, an object preview on the right, and a central area where settings are located. The vertical splitters separating these sections each have a pale grey, vertical grab handle.



To resize the panel list or preview, as well as the area in the middle, move your mouse pointer over the vertical grab handle: when the splitter cursor  can be seen, click and drag to the left or right. In order to move a splitter, the dialog box typically needs to be wider than its minimum width.

The Library Browser side window also has a number of splitters, mostly vertical. See *The Library Browser on page 946*.

## KEYBOARD NAVIGATION

Dialog panels and settings can be accessed using the mouse. You can also navigate the settings on a given dialog panel using the keyboard. For example:

- Line items in tree lists can be browsed using the arrow keys. **Up** and **Down** navigate the list, while **Left** and **Right** expand and contract categories.
- Press the **Tab** key to shift focus from the tree list to the first setting on the selected panel.

- Press the **Tab** key to shift focus from one setting to the next, or **Shift + Tab** to go in the reverse direction.
- A check box can be checked or cleared by pressing the **Spacebar** or the **+** or **-** keys, respectively, while it is in focus.
- Columns of radio buttons can be navigated using the **Up** and **Down** arrow keys; rows can be navigated using the **Left** and **Right** arrows. Select a radio button by pressing the **Spacebar** while it is in focus.
- Settings in list boxes can be navigated using the **Up** and **Down** arrow keys. When a check box is in focus, it can be checked or cleared by pressing the **Spacebar**.
- Drop-down lists can be browsed using the **Up** and **Down** arrow keys. When the mouse pointer is directly over the drop-down, the mouse scroll wheel can also be used; on a Mac, the list must also be expanded. In Windows only, you can press **Tab** to select the highlighted item in the list and proceed to the next setting.
- Settings with spin control arrows  can be adjusted by typing in the text field or using the **Up** and **Down** arrow keys. When the mouse pointer is directly over the setting, the mouse scroll wheel can also be used.
- Slider bars  can be adjusted by typing in the text field or using the **Left** and **Right** arrow keys. When the mouse pointer is directly over the slider bar, the mouse scroll wheel can also be used.
- Line items in tables can be group selected using the **Ctrl** or **Shift** keys, or by pressing **Ctrl + A**.
- Press **Enter** on your keyboard to close most dialogs and apply your changes.
- In the Mac version, **Command + .** closes dialogs.

Note: Keyboard navigation in dialogs may vary somewhat depending on your computer platform.

In the Mac version of the software, Dictation is supported in dialogs. Select **Edit> Start Dictation**, then open a dialog. Say the word “Numeral” before a number to enter it as a numeric value or immediately follow a number with a unit such as “foot” to enter it as a measurement.

## Edit Handles

A selected object has edit handles that can be used to modify its size, position, and orientation. When you move the pointer over an edit handle, information about what it does displays in the Status Bar and the pointer changes to suggest how you can use it.

The edit handles that display depend on the type of object selected, the current view, and how far you are zoomed out. Edit handles do not resize as you zoom in or out. If you are zoomed out far enough, some edit handles may be hidden so that they do not stack over one another. As you zoom in, these handles become visible again.

How each handle behaves when it is clicked and dragged may depend on which **Edit Behavior**  is currently active. See [Defaults, Preferences, and Edit Behaviors on page 206](#).

 You can cancel any edit handle operation before it is completed by pressing the Esc key on your keyboard or by pressing any two mouse buttons at the same time.

### MOVE EDIT HANDLE

 The square Move handle located at the center of a selected box or polyline-based object, or at the center of a group of selected objects, lets you move the selection orthogonal, or at right angles to, its edges. When you position the mouse pointer over the Move handle, it displays a four-headed arrow. See [Moving Objects on page 243](#).

Depending on the type of object(s) selected and how far you are zoomed in or out, the position of the Move handle may shift so that it remains on-screen. See [Zoom Tools on page 153](#).

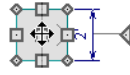

## RESHAPE/RESIZE EDIT HANDLES

↔ Square edit handles on the edges and corners of a selected object allow you to resize the object by moving its edges. A two-headed arrow indicates that the object's edge or corner can be moved in the direction of the arrows. When multiple objects are selected, the Resize handle is not available. See [Resizing Objects on page 253](#).

Depending on the type of object selected and how far you are zoomed in or out, the Resize handles may not display on-screen.



In the case of a selected line-based object, clicking and dragging the Resize edit handle will move the object perpendicular to itself. See [Editing Line-Based Objects on page 216](#).

## ROTATE EDIT HANDLE

↻ The triangular Rotate handle lets you rotate the selected object or group of objects. The Rotate handle is located adjacent to either the object's selected edge or its front if it has one, and when you move your mouse pointer over this handle, it displays a circular arrow. See [Rotating Objects on page 259](#).

A selection's Rotate handle will display regardless of how far you are zoomed out; however, it is possible to zoom in far enough that it no longer can be seen.



## OTHER EDIT HANDLES

In addition to the Move, Reshape/Resize, and Rotate edit handles, a variety of objects in Chief Architect have additional edit handles for special purposes. Examples include:

- Same Wall Type and Edit Wall Intersection edit handles. See [Edit Handles for Walls on page 372](#).
- Change Swing/Hinge Side edit handle for doors. See [Changing Door Swings on page 553](#).
- Add Extension and Extension Line End edit handles for dimension lines. See [Editing Dimension Lines on page 476](#).
- Move and Rotate edit handles for object labels. See [Label Panel on page 700](#).
- Resize edit handles for Schedule columns. See [Editing Schedules on page 685](#).

---

# The Status Bar

The Status Bar at the bottom of the main program window displays information about the current state of the program.

This information depends on a variety of conditions such as settings in the Preferences dialog, the type of object selected, and the current position of the pointer. Examples of information that may be reported include:



- The type of object currently selected or the total number of group-selected objects.
- Plan file name and view information when a layout box is selected.
- A description of the edit handle that the pointer is over.
- A brief description of the toolbar button or menu item that the mouse pointer is positioned over.
- The name of the active tool, a brief description of that tool, and its hotkey, if it has one.
- The length and/or angle of an object as it is being drawn.
- Basic information about a selected library object, folder, or catalog.
- The current floor level or layout page.
- The layer that the selected object is on and its Drawing Group.
- The size of the active window in pixels.
- Whether a camera view is rendering or has finished rendering.
- Samples of indirect lighting per second in camera views with GPU Ray Tracing.
- The screen redraw time.
- The Current CAD Layer.
- The current CAD coordinates of the mouse pointer.

The number format used in the Status Bar is set in the Dimension Defaults dialog, while the angle style can be specified in the Number Style/Angle Style dialog. See [Primary Format Panel on page 459](#) and [Dialog Number/Angle Style Dialog on page 126](#).

---

## Message Boxes

As you work in Chief Architect, the program will occasionally prompt you to examine your settings, alert you if you command it to do something that could potentially cause a problem, or notify you if it encounters a problem that needs your attention.

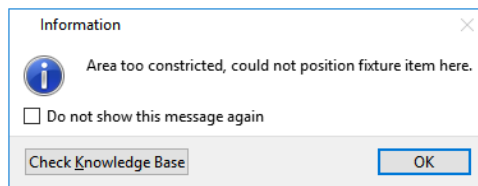

Situations where such message boxes may display include:

- Closing a file or view without saving;
- Modifying an object that is set to rebuild automatically;
- A file referenced outside the program, such as an image or texture, is missing;
- Creating an object in a space too small to contain it.

As with dialog boxes, you can access the options in a message box using the mouse or navigate them using the keyboard.

A few messages have a **Send Report** button. Click this button to send details regarding the issue that prompted the message to Chief Architect via the internet.

Some message boxes include a “Remember my choice” or a “Do not show this again” check box. Check this box to prevent messages of this specific type from displaying in the future. When this box is checked, some options in the message box may become inactive.

To allow all message boxes to display again, click the **Reset Message Boxes** button in the Preferences dialog. See [Reset Options Panel on page 125](#).

## NAME PROMPT

In dialogs throughout the program, there are opportunities to create new entities that require a name. Examples include:

- The **Copy** button in the Saved Defaults dialog.
- The **Copy Set** button in the Layer Display Options dialog.
- The **Rename** button in the Schedule Specification dialog.

When you click a **New**, **Copy**, or **Rename** button in a dialog, a Name Prompt dialog will open.

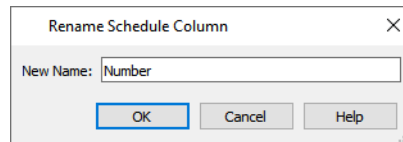

For best results, type a short, descriptive, and unique name and then click **OK**.

---

# Preferences and Default Settings

Preferences and default settings control many aspects of the user interface and tool behavior in Chief Architect. You can use these settings to customize the program to suit your personal work style.

For more information about defaults and preferences, see [Preferences and Default Settings on page 76](#).

## PREFERENCES



Preference settings let you change program behavior to suit your workflow. For example, you can:

- Turn certain display elements on or off.
- Choose background and editing feedback colors.
- Select a color theme for the dialog boxes, toolbars, and other elements of the program interface.
- Set the frequency of autosaves, the maximum number of “undos,” and file locking.
- Set the default folders for various files.
- Control the editing behaviors of objects.
- Specify the active materials Master List file.
- Set rendering specifications to maximize efficiency and quality.

Preference settings are global, affecting all plan and layout files.

## DEFAULTS

Most objects in Chief Architect derive their initial properties from their respective default dialogs.

For example, a newly placed **Window**  gets its initial values from the Window Defaults dialog and a newly placed **Hinged Door**  gets its initial values from the Door Defaults dialog.

Once an object is placed in a plan, its initial properties can be overridden, but setting up your defaults before you begin drawing can save you considerable time as you build a model in the program.

Default settings, unlike Preferences, are file specific.

## DYNAMIC DEFAULTS

Most default settings are static: if you change one, any objects of that type in the current file will not be affected. A few defaults, however, are dynamic: they are tied to existing objects in the drawing and if you change the default, those objects may be affected. See *Dynamic Defaults on page 79*.

## TEMPLATE PLANS

You can set up an otherwise empty plan with the default settings of your choice and use it as your template for new, blank plans. See *Template Files on page 87*.

---

# Drawing a Plan

When you draw a plan in Chief Architect, you are placing 3D objects that represent building components. Chief Architect comes with predefined default settings so you can start drawing plans immediately. You should review these default settings to be sure they match your drawing and building methods. See *Preferences and Default Settings on page 76*.

## SET THE DEFAULTS

1. Open a new plan using the template of your choice. See *Template Files on page 38*.
2. Set the structural defaults:
  - Floor Defaults. Set the default ceiling height for Floor 1. See *Floor Defaults Dialog on page 731*.
  - Foundation Defaults. Set the foundation specifics such as type, footing size, and stem wall height. See *Foundation Defaults on page 706*.
  - Framing Defaults. Set the floor framing specifications, including type and dimensions. See *Framing Defaults on page 851*.
  - Default Wall Types. Specify the defaults for walls and railings. See *Wall, Railing, and Fencing Defaults on page 343*.
3. Set material defaults for roof, walls, and rooms (optional). See *Material Defaults on page 1051*.
4. Set style defaults for doors, windows, molding, cabinets and other objects.

## DRAW THE FLOORS

1. While the size of the drawing area in Chief Architect is limited only by the resources on your computer, it is best to begin your drawing near the origin, 0,0. See *3D Drafting on page 13*.
2. Draw the exterior walls on Floor 1. See *Creating Walls on page 357*.
3. Adjust the perimeter shape and size as required. See *Using the Edit Handles on page 369*.
4. Place any first floor bearing walls.
5. Define types for special rooms such as garages and decks in the plan. See *Room Types and Functions on page 415*.
6. Place perimeter doors and windows. See *Doors on page 543* and *Windows on page 576*.
7. Build additional floors. See *Adding Floors on page 732*.

8. Specify the default ceiling height for each floor as soon as it is created. See *Floor Defaults Dialog on page 731*.
9. Adjust the perimeter shape of additional floors as needed. See *Editing Walls on page 368*.
10. Align edited or moved walls with those above or below where appropriate. See *Aligning Walls on page 375*.

## ENTERING DIMENSIONS

When using U.S. Units, enter distances as inches or feet and inches, in fractional or decimal form. Millimeters are the default unit for all metric distances. See *Dimensions on page 448*.

- To enter feet, include the ( ' ) marker or the program assumes inches.
- In most cases, the program allows precision to 1/128th of an inch. Fractions with denominators 2, 4, 8 and 16 are allowed.
- The program usually converts decimals to fractions.
- You can enter angles as decimal degrees, degrees, minutes, and seconds, quadrant bearings, or azimuth bearings. See *Dialog Number/Angle Style Dialog on page 126*.

## BUILD THE FOUNDATION

1. Derive the foundation plan from the first floor. See *Building a Foundation on page 710*.
2. Adjust the foundation perimeter shape as needed.
3. Place interior foundation walls as needed for the first floor bearing walls.
4. Place any other foundation walls required.
5. **Align with Above** as needed. See *Aligning Walls on page 375*.

## ADD STRUCTURE AND DETAILS

1. Build non-structural interior walls. Begin on floor one and work up in multiple story structures.
2. Add walls where needed to create features such as chimney chases, plumbing walls, or Open Below areas.
3. Finish the relevant interior structure including interior doors, doorways, cabinets, fixtures, and fireplaces.
4. Build the roof planes. If you generate the roof automatically, remember to carry the roof directives in the walls from the first floor up to the top floor for multiple story structures. See *Roofs on page 791*.
5. Build the framing. See *Framing on page 850*.
6. Build the terrain and landscaping. See *Terrain on page 1243*.
7. Create the plot plan and plan footprint. See *Plot Plans and Plan Footprints on page 1245*.
8. Create any necessary views and print the plan and use **CAD Detail from View** to create 2D elevations and plan details. Use and modify details from the Library, as well. See *CAD Details on page 337*.

## CREATE THE LAYOUT

1. If one does not exist, create a Layout file with a title block, placing the border, title block, and other text on page 0. See *Layout on page 1333*.

2. Send views to the layout, starting with layout page 1. See *Sending Views to Layout on page 1338*.
3. Print the layout. See *Printing and Plotting on page 1363*.

---

## Viewing Your Plan

You can see your model in a variety of different 2D and 3D views. You can display more than one view at a time; and in any view, you can pan or zoom in or out. See *Window and View Tools on page 143*.

Plan view is a 2D view of the model most commonly used for drawing and editing. Each floor displays separately; however, you have extensive control over which objects display at any given time, can easily switch between floors, and can also display items other floors for reference. See *Multiple Floors on page 730*.

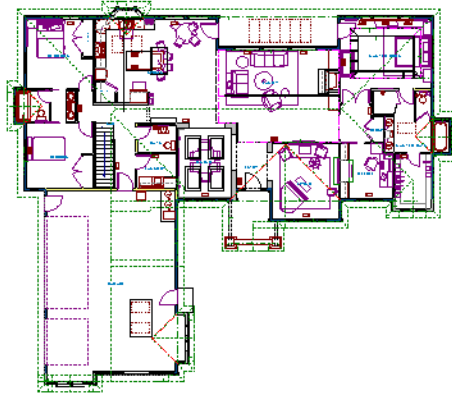

You can create interior and exterior 3D views of your model from any perspective. As in plan view, you can select and edit many objects in 3D views and control which objects are visible. See *3D Views on page 1079*.

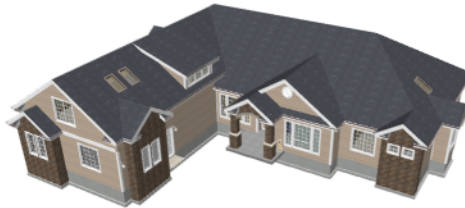

You can also create **Floor Overviews** that show only the current floor plus any floors beneath it. Ceilings on the current floor are omitted so you can see the interior, visualize the relationships between spaces, and plan traffic flow.

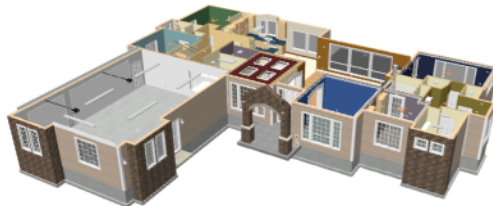

**Framing Overviews** display framing in 3D, provided that framing has been built. You can customize 3D views to serve special purposes such as this.

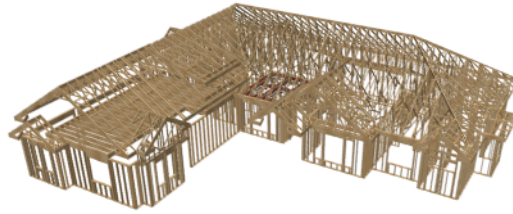

A variety of rendering techniques let you produce customized 3D views, from detail drawings to photorealistic Ray Trace views to artistic presentation views.

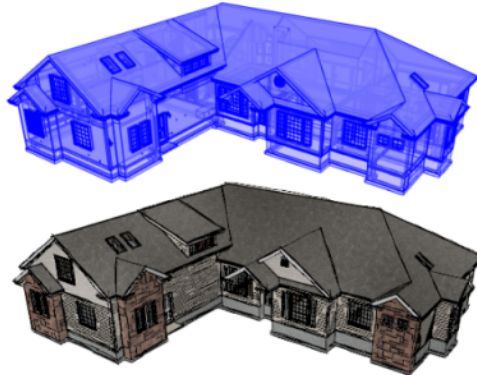

The Cross Section and Elevation camera tools create scaled 2D views of a model's exterior and interior that can be dimensioned and annotated. Just as in other views, you can select and edit objects in a Cross Section/Elevation view as well as control which objects display.

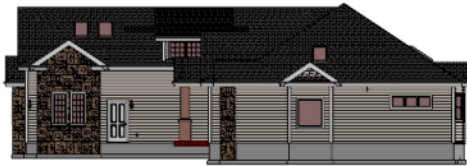

## LAYOUT FILES

 All plan views can be sent to a layout where they can be arranged to produce full construction documentation. See [Sending Views to Layout on page 1338](#).

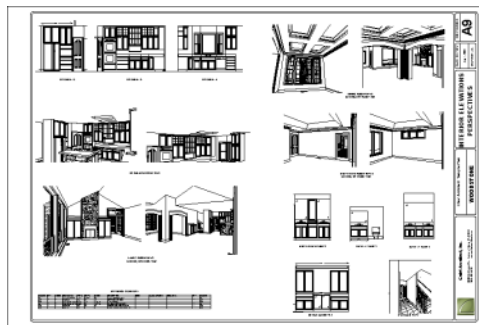

All views can also be exported as a graphic image. See [To export a picture on page 1191](#).

---

## Sharing Your Files with Clients

Chief Architect users have the option of letting their clients review plan and layout files on their own computers, at their convenience, using the Chief Architect Viewer. The Chief Architect Viewer allows clients to open plan and layout files, create 3D views, and add text annotations without making any changes to the actual model.

To share files using the Chief Architect Viewer, first invite a client to request a copy of the Viewer at [chiefarchitect.com](http://chiefarchitect.com).

To ensure that all custom backdrops, images and material textures are included, use the **Backup Entire Plan**  tool when preparing to send files to your client. See *Backup Entire Plan or Layout on page 55*.

You can also invite clients to explore the 3D model of their project using the **3D Viewer** mobile app. Learn more at: [chiefarchitect.com/products/3d-viewer/](http://chiefarchitect.com/products/3d-viewer/)

---

## Getting Help

 There are many forms of help available in Chief Architect Premier including: Tool Tips, the Status Bar, and the online Help menu. See *Resources and Support on page 1403*.

All these forms of help assume you have a basic working knowledge of your operating system, including how to use a mouse, open, close and save files, copy, paste, and right-click to access contextual menus. Help also assumes you are familiar with basic computer terminology.

More information is available on Chief Architect's website, [chiefarchitect.com](http://chiefarchitect.com).

### TOOL TIPS

When you move the pointer over a toolbar button or menu item, a **Tool Tip** displays, offering a brief description of the tool. More information displays in the Status Bar at the bottom of the window. The Status Bar also reports information about the currently active tool or the currently selected object. See *The Status Bar on page 24*.

### CONTEXTUAL HELP

 Chief Architect Premier's **Help** is a searchable menu that provides information about all of the tools in the program. Select **Help> Launch Help** or press the F1 key to open the program's Help and explore the table of Contents, browse the Index, or Search for keywords.

The Help can be used to provide instant information about toolbar buttons, menu items, and objects in your plan.

- Position the mouse pointer over a toolbar button or menu item, then press the F1 key to open the Help to a page with more information about the tool.
- When an object is selected, press the F1 key to open the Help to a page with information about that object. If you position the mouse pointer over one of the selected object's edit handles and press F1, a page with information about that handle will display instead.
- Press the **Help** button in any dialog box to open online Help to a page describing the options in that dialog.

When the Help is open, it will update automatically to show information about the currently selected object, active tool or dialog, or highlighted item. If you would like to turn off this dynamic behavior, click the **Prevent Help from Updating Dynamically**  button at the top of the Help window.

Additional buttons at the top of the Help window allow you to zoom as well as search the current page.

Chief Architect strives to make our documentation as helpful as possible. Please send any suggestions to: [documentation@chiefarchitect.com](mailto:documentation@chiefarchitect.com).

---

## About Chief Architect

Select **Help> About Chief Architect** in Windows® or **Chief Architect> About Chief Architect** in macOS™ to view information about your software license, the program's version number, and its release date.

Contact information for Chief Architect, Inc. is available on the MORE INFORMATION panel.

---

## Chief Architect Trial Software

Chief Architect Premier has a Trial version available for free download at [chiefarchitect.com](http://chiefarchitect.com).



The Trial software offers the same functionality as a purchased license with a few limitations:

- File Saving
- Printing
- File Exporting
- Recording of Walkthroughs
- Printing or Exporting of Materials Lists
- Library Browser restrictions
- Linked Plans in the Reference Display
- Linked Callouts
- Use of the Time Tracker utility
- Use of the CAD Detail from View tool
- Creating or saving Plan Database files
- Exporting of Layer Sets

Full details can be found in the software's Help and at [chiefarchitect.com](http://chiefarchitect.com).

### CONVERTING THE TRIAL VERSION

An installation of any of our Trial programs can be converted into a full working version of the program at any time by purchasing a software license. There are several ways to begin this process in the Trial:

- Click the **Purchase Full Version Now** button in any Trial Restriction message box.
- Select **Help> Purchase Chief Architect Premier** .
- Select **File> Dashboard**  and then click the **Purchase Full Version Now** button.

Once you have purchased a license, you can activate it while the Trial software is running.

#### *To activate the full version*

1. Select **Help> Activate Full Version**.
2. In the Product Activation dialog, type or paste the **Product Key** associated with your software license.
3. Click the **Activate Full Version** button.





# File Management

## Chapter 2

Chief Architect Premier reads and edits two main document types: **.plan** files and **.layout** files. The complete 3D model of a structure, surrounding terrain and any CAD data associated with it are stored in the plan file. Data used to create working drawings and the links to various views or details are stored in the layout file.

All commands related to opening, saving and closing plans are located in the File menu. You can also open plans from the Dashboard window. See *Dashboard on page 11*.

Just as with files created in other software applications, you should back up your plan and layout files externally on a regular basis to avoid accidental loss of work.

### TOPICS

<b>Compatibility with Previous Versions</b> .....	<b>35</b>
<b>Organizing Your Files</b> .....	<b>36</b>
<b>Chief Architect Premier Data</b> .....	<b>37</b>
<b>Creating a New Plan or Layout</b> .....	<b>38</b>
<b>Saving, Exporting, and Backing Up Files</b> .....	<b>39</b>
<b>Auto Archive</b> .....	<b>42</b>
<b>Opening and Importing Files</b> .....	<b>44</b>
<b>Plan Databases</b> .....	<b>46</b>
<b>Searching for Plans</b> .....	<b>48</b>
<b>Linked and Referenced Files</b> .....	<b>51</b>
<b>Backup Entire Plan or Layout</b> .....	<b>55</b>
<b>Exiting Chief Architect</b> .....	<b>56</b>

---

## Compatibility with Previous Versions

Plans and layout files produced in the following programs can all be read by Chief Architect Premier X15.

- Chief Architect® 10.0 through X14
- All Better Homes and Gardens Home Designer® products, Interior Designer, and Landscaping and Deck Designer, Versions 7 and 8.
- All Chief Architect Home Designer® products, Interior Designer, and Landscaping and Deck Designer, Versions 9 through 2023.

Only the **.plan** and **.layout** files from prior versions can be opened in Chief Architect Premier X15. A number of steps are recommended when migrating plans created in an earlier program version into Chief Architect Premier X15. Before doing so, see [Getting Started Checklist on page 1409](#).



Files that have been opened and saved in Chief Architect Premier X15 cannot be read by any of the program versions listed above. To continue to read files in the program in which they were created, be sure to create copies of your files before opening them in version X15.

Plans and layout files produced in the Windows® version of Chief Architect Premier X15 can be read in the Mac® version, and vice versa.

### FILE ASSOCIATION

Although multiple versions of Chief Architect can be installed on a computer, the operating system will only associate **.plan**, **.layout**, **.calib**, and **.calibz** files with one of them. If they are not associated with Chief Architect Premier X15, click the **Associate Files with this Program** button in the Preferences dialog. See [File Management Panel on page 104](#).

### OPENING CHIEF ARCHITECT PLANS IN HOME DESIGNER PROGRAMS

Plans created in Chief Architect Versions 10 through X15 can be opened in the latest Home Designer programs for viewing and annotating, but not for general editing or drawing of architectural objects.

Plans created in build 11.4 or later of Chief Architect X1, or in later program versions, can be set to allow limited editability in Home Designer programs. When this permission is enabled, a Home Designer user can use all of their program's drawing tools and can edit objects in the plan that those tools can create. If an object cannot be created in the Home Designer program, however, it will not be editable.

Please note, too, that if a plan has more floors than the Home Designer program supports, the entire plan can be viewed and annotated only.

To protect some objects from being edited when a file with editing permission is opened in a Home Designer program, consider locking their layers. See [Locking Layers on page 178](#).

**Allow Editing in Select Home Designer Products** can be enabled or disabled only when the file is opened in Chief Architect Premier. See [General Plan Defaults Dialog on page 92](#).

---

## Organizing Your Files

You should keep your plan and layout files separate from the support files needed to run Chief Architect. To keep files organized, you may find it helpful to create a new folder for each project.

Chief Architect files may use imported images, textures and other custom content saved in their own external data files. Consider storing copies of all external files in the same folder as the plan and layout files that use them so that they are easily found. See [Adding Library Content on page 965](#).

Here is one way to organize your files:

- Create a folder in your Documents directory called “Chief Architect Plans” or another name you prefer. See your operating system’s Help to learn how to create folders.
- Inside this folder, make a new folder for each client or project. Save all the files for that client or project inside this folder, including plan and layout files and referenced external files. See [Saving, Exporting, and Backing Up Files on page 39](#).

Bear in mind, though, that path names exceeding 260 characters cannot be opened by Chief Architect. As a result, it is a good idea to limit the number of embedded folders you use in your file organization method.

Once you understand the file management of Chief Architect, you should decide on a naming convention that suits your needs.

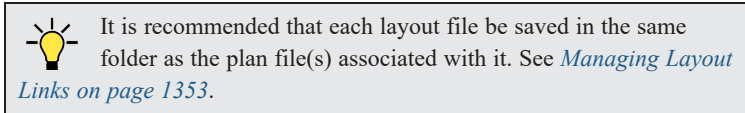

### ***To specify a default Save As location***

1. Select **Edit> Preferences** , then select New Plans from Category list. See [New Plans Panel on page 108](#).
2. Under Open and Save As, click **Use this Folder**. The **Browse** button becomes available.
3. Browse to the folder you plan to save your projects in. Click **OK**.

## **THUMBNAIL IMAGES**

A thumbnail is a miniature image that helps identify a file in the Open Plan File dialog in the Windows version of the software and in the Find Plan Assistant. See [Searching for Plans on page 48](#).

If thumbnails are enabled in the Preferences dialog, the program automatically creates one when you first save a new plan or layout. You can, however, create a custom thumbnail using any view as well as choose to generate small or large thumbnails. See [File Management Panel on page 104](#).

### ***To create a custom thumbnail image***

1. You must save the file and give it a name before you can save a thumbnail.
2. Create the 2D or 3D view that you want to use as a thumbnail for the current file.
3. With the desired view active, select **File> Save Thumbnail Image** .

Thumbnail images are saved in the plan or layout file that they are associated with.

## Chief Architect Premier Data

When Chief Architect Premier X15 is installed, the program automatically creates a folder in the user Documents directory called **Chief Architect Premier X15 Data**. This folder contains important user-specific information saved in the following folders and files and should not be moved, renamed or deleted:

- **Archives** - A folder of automatically archived plan and layout files. See *Auto Archive on page 42*.
- **Backdrops** - A folder of custom backdrop images. See *3D Backdrops on page 1099*.
- **Hotkeys** - A folder of hotkey assignments. See *Hotkeys on page 137*.
- **Images** - A folder of custom images. See *Using the Contextual Menu on page 966*.
- **lex** - A folder of customized dictionaries. See *Spell Check on page 517*.
- **Database Libraries** - A folder of user library data. See *Library Content on page 961*.
- **Scripts** - A folder for custom Ruby scripts. See *Ruby in Chief Architect on page 1386*.
- **Templates** - A folder of plan and layout template files. See *Template Files on page 87*.
- **Textures** - A folder where you can save image files used to create custom material textures. See *Creating Materials on page 1060*.
- **Toolbars** - A folder of customized toolbar files. See *Toolbar Customization Dialog on page 134*.
- **mmaster.mat** - The Master Materials List file. See *The Master List on page 1327*.
- **sheetSizes.sheet** - A list of user-created Drawing Sheets. See *Customize Sheet Sizes Dialog on page 1370*.
- **\_MigrateBackup** - If you migrated legacy settings into Version X15, additional folders with names appended with **\_MigrateBackup** may also be present.



If the Chief Architect Premier X15 Data folder is renamed, moved or deleted, the program will automatically replace it using default information from the program's installation folder. When this occurs, customized user settings and custom user library content will not be available.

### DATA FOLDER NAME AND LOCATION

The name of the Chief Architect Premier X15 Data folder cannot be changed, but you can specify its location on your system in the Preferences dialog. See *Folders Panel on page 106*.

If you specify a new location for this folder, the program will not migrate any custom user settings that you might have. Instead, it will automatically create a new folder at that location containing default information from the Chief Architect Premier X15 installation folder. If you would like to copy custom settings to the new location, you can do this yourself in an operating system window.

When specifying a location for the Data folder, bear these considerations in mind:

- If you move the Chief Architect Premier X15 Data folder on your computer without specifying its location in Preferences, the program will automatically replace the folder in its default location using default information from the software's installation folder.
- The same will result if you specify a location on a network or removable device and that location becomes inaccessible. For this reason, it is best to use a location on your local hard drive.
- The User Database Libraries in particular may contain a large amount of data. Whatever location you choose to use must be located on a hard drive with sufficient space to hold these files.

Just as with your plan and layout files, it is a good idea to back up your Chief Architect Premier X15 Data folder.

Because the Chief Architect Premier X15 Data contains custom user data, it is not deleted when the program is uninstalled.

---

## Creating a New Plan or Layout

 To create a new, blank plan, select **File> New Plan**. You can also choose **New Plan** in the Dashboard window. See [Dashboard on page 11](#).

 Create a new layout file by selecting **File> New Layout** or by sending a view to layout when no layout file is yet open or associated with the current plan file. See [Creating a Layout File on page 1336](#).

By default, a new layout file will be assigned the same name of the first plan file sent to it, associating the layout files with the plan files used.

New plan and layout files derive their default settings from the currently selected template files. See [Template Files on page 87](#).

New, blank plans are called **Untitled.plan** and new, blank layout files, **Untitled.layout**. Unless these files are named and saved, they will be lost when closed. See [Saving, Exporting, and Backing Up Files on page 39](#).

### UNITS OF MEASUREMENT

All plan and layout files save measurements in either U.S. or metric units. New files are created using one or the other, depending on the current setting in the Preferences dialog. When the program is first installed, the Windows OS setting for units determines what system is used. See [New Plans Panel on page 108](#).

A plan or layout file's unit of measurement must be specified before it is created and cannot be changed later. If you normally work in one set of units but need to create a new file using the other, select **File> Templates> New Plan From Template**  to open a new file using an appropriate template without changing your Preferences settings. See [Using Template Files on page 87](#).

While it is recommended that you create new plans using the type of unit that you plan to use, you can display dimensions using any type of unit. See [Dimension Preferences and Defaults on page 449](#).

### TEMPLATE FILES

New plan and layout files are created as copies of the current template files specified in the Preferences dialog. See [Template Files on page 87](#).

Commonly used settings, defaults and other information are included in template files. You can customize the settings in a template file to fit your work style and then save your changes as a new template file. See [To create a plan template on page 89](#).

If no template has been specified in the Preferences dialog, new plans and layouts are created using the system defaults. System defaults cannot be modified.

When Chief Architect opens a new, blank plan or layout file, the new file is actually a copy of a template using either metric or U.S. units of measurement and predefined default settings, layer settings, wall definitions, and page setup information.

### SELECT TEMPLATE DIALOG

When a new, blank plan or layout file is opened in Chief Architect, the new file is actually a copy of a template using either metric or U.S. units of measurement and predefined default settings, layer settings, wall definitions, and page setup information.

Creating a new plan without referencing a template file is not recommended. If you try to create a new plan or layout using a template file that is not available, the Select Template dialog will prompt you to specify a template for the new file you are creating.

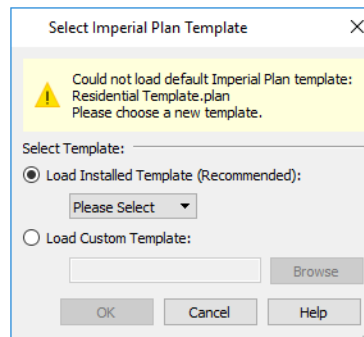

- Select **Load Installed Template (Recommended)**, then select a template file from the drop-down list.
- Select **Load Custom Template**, then click the **Browse** button and browse to a plan or layout file saved on your computer.
- You can also type or paste the full path name of a file in the text field.

If you encounter this dialog, make sure that the program Data folder is at a location that can be accessed by the program. You may also want to reset your template files to the defaults installed with the program. See [Chief Architect Premier Data on page 37](#) and [Reset Options Panel on page 125](#).

---

## Saving, Exporting, and Backing Up Files

Saving, exporting, and backing up your files are three separate tasks that accomplish different things:

- Saving a plan or layout file retains your work so that it can be later opened in Chief Architect.
- Exporting a file allows you to save certain kinds of data in a format that can be used by a program other than Chief Architect.
- Backing up your files involves taking steps to make sure that your valuable data is protected and available when needed.



Whether you are saving, exporting, or backing up your data, it is important that you select a location on your computer for the files you create, and also specify a short, meaningful name that you will be able to identify in the future.

### *To save an untitled plan or layout file*

1. Select **File> Save As**  to open the Save File dialog.
2. Specify a location on your local computer where you would like to save the file. See [Organizing Your Files on page 36](#).
3. In the **File name** text field, type a name for the file.
4. Chief Architect automatically assigns the **File of type** and file extension **.plan** to plan files and **.layout** to layout files.
5. When both the Save in location and File name are correct, click **Save**.

 Although the program warns you if you try to exit without saving, you should get in the habit of saving plan files before exiting the program.

## SAVING PLAN AND LAYOUT FILES

When you first save a new, untitled file, you must select a location for it on your computer and give it a name. There are two options for saving plan and layout files: **File> Save**  and **File> Save As** .



Both **Save** and **Save As** can be used to save your plan and layout files; however, they accomplish this in two different ways:



**Save** saves the current state of your plan or layout file without changing its name and should normally be used for saving your work.



**Save As** opens the Save File dialog, allowing you to save the plan or layout file using a different name or location on your computer.

Initially, all **Open**  and **Save As**  operations go to your Documents directory. After that, the location last visited is remembered and subsequent **Open** or **Save As** commands default to the directory last used for that operation. This path is saved when the program exits. The next time Chief Architect is launched, these defaults are used.

If you prefer, you can instead specify a directory to be used for all **Open** or **Save As** operations in the **Preferences**  dialog. See *New Plans Panel on page 108*.

## SAVED VIEWS

All saved camera views, plan views, and CAD Details are saved with their plan file. See *View Windows on page 144*.

When saving a layout, the program saves all pages of the layout, all the links to the various views saved in the layout, and all the CAD objects added to the **.layout** file.

By default, a new layout file is assigned the same name as the first plan file from which a view is sent to it. It is also saved in the same directory as the plan file. If no view has been sent to a layout, it remains untitled until you save it.

## SAVE FILE DIALOG

The Save File dialog uses the operating system's file save dialog format, and is also used when exporting files. The dialog name may vary, depending on the type of file being saved or exported.

A similar Select Folder dialog allows you to select a folder to which files can be exported.



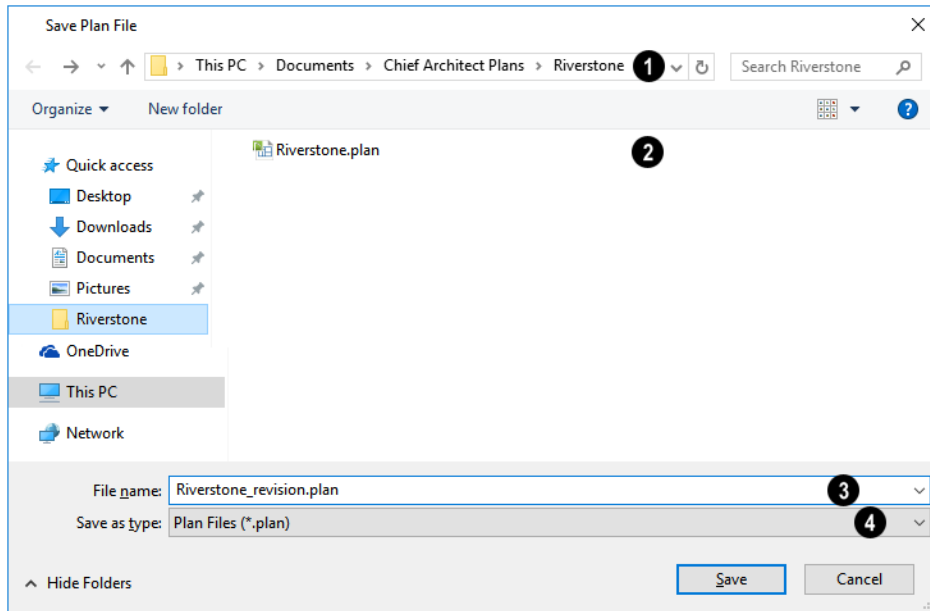

### 1 Location

Choose a location on your local computer for the file you are saving.

### 2 Files

Any existing folders and/or files in the current location display here.

### 3 File Name

In the **File Name** field, type a name for the file. If you select an existing file from the space above, its name will display here automatically.

### 4 Save as Type

When saving a file, the program will choose the appropriate file type from the **Save as type** drop-down list. When exporting, you may need to choose a specific file type.

## SAVING REVISION FILES

Revisions are a common aspect of any design project. There are a number of possible strategies for organizing revision files:

- Prepending the file name;
- Appending the file name;
- Saving revisions in separate folders.

To avoid confusion and potential mistakes, it is recommended that you always give files unique names - including revision files. If you choose to organize your revisions by saving them in separate folders, you should also give each file a unique name that makes it impossible to confuse it with another file saved in a different folder.

## EXPORTING FILES

Chief Architect has a number of options for exporting information out of and importing information into your drawings. See *Importing and Exporting on page 1222*.

Often, file export dialogs are simply versions of the Save File dialog. See *Save File Dialog on page 40*, above.

Similarly, file import dialogs are often similar to the Open File dialog. See [Importing Files on page 45](#).

## BACKUP ENTIRE PLAN

**File > Save As**  is a simple way to transfer a plan or layout to a different location on your computer. Bear in mind, though, that plan and layout files often reference external data files such as imported textures, images, and backdrops. These external files are not affected when **Save As** is used.

If you transfer a plan file from one computer to another, the program will warn you of missing files if the external data files used by the plan cannot be found when you open it.

Layouts are also dynamically linked to plan files. When transferring layout files to another computer, be aware that the plan files are also external file references and are not actually contained in the layout.

When transferring plans or layouts to another computer that does not have these external files, use the **Backup Entire Plan**  tool. See [Backup Entire Plan or Layout on page 55](#).

## BACKING UP YOUR FILES

It is always a good idea to create backup copies of all your important files on your computer.

It is strongly recommended, however, that you never save directly:

- Across a network, such as onto a server;
- Onto removable media such as a USB thumb drive.
- Across the Internet.

Instead, copy your files to such locations only after you have saved them on your computer's hard drive and exited the program.

Similarly, you should never open files saved in these locations. Copy the files to the local hard drive, and then open them. See [Opening and Importing Files on page 44](#).

Archive folders are used by Chief Architect to manage prior versions of your files. You should not view these files as a substitute for your own backup routine, and should never save a file in an archive folder. See [Auto Archive on page 42](#).

When backing up your Chief Architect files, consider backing up not only your **.plan** and **.layout** files, but your custom user data, as well - including library content, toolbar configurations, and textures. This custom data is all located in the Chief Architect Premier Data folder, so it can be easily backed up. See [Chief Architect Premier Data on page 37](#).

You can, if you wish, create a folder inside the Data folder for your **.plan** and **.layout** files, as well. See [Organizing Your Files on page 36](#).

---

## Auto Archive

The first time a plan or layout is saved, an Archive folder is automatically created in the Chief Architect Premier X15 Data folder. The Archive folder contains Auto Save and Archive files.

The program will also create Auto Save files for unsaved plans and layouts provided that they have been open for longer than the Auto Save frequency setting in the Preferences dialog. See [Auto Save Files on page 44](#), below.

 Auto Save and Archive files should not be viewed as a substitute for regularly saving your work by selecting **File> Save** or pressing **Ctrl + S** on the keyboard, nor should they be considered an alternative to your own file backup routine.

## ARCHIVE FILES

Every time a drawing is saved, Archive files that keep a historical archive of your plan are automatically created or updated.

Files can be archived by hour, day or most recent save. They are renamed according to which archiving option is selected in the Preferences dialog. See *File Management Panel on page 104*.



JonesResidence.plan



JonesResidence\_2023\_1\_15.plan



JonesResidence\_2023\_1\_15\_13.plan

 Regardless of what archiving option you select in the Preferences dialog, if you do not save your work regularly, your archive files will not be updated.

Plan, layout and related files from previous versions of the program are automatically moved to the archive folder when the plan is opened and saved in Chief Architect Premier X15.

Archive files are meant to be for emergency use only. If you must access an archive file, open it as you would any other file. As soon as the file is open, use **Save As**  to save this file to another location.

## LEGACY ARCHIVE FILES

Plan and layout files saved in the current program version are not backwards-compatible: that is, they cannot be opened in older versions of the software.

If you open a Chief Architect plan or layout file from a previous program version and immediately **Save** it (not **Save As**), the Auto Archive utility will create an additional archive file using the original program version format. This archive file is a copy of the original and can still be opened in the original program version.

If you open and **Save** a Chief Architect Version 10 plan or layout file, the legacy archive file name will be appended “\_v10” to help distinguish it from other archived .plan or .layout files of the same name, and a copy of its archive folder will be created in the Chief Architect Premier X15 Archives folder.

## MANAGE ARCHIVES

Chief Architect offers two convenient ways to access Archive folders.

- Select **File> Manage Auto Archives**  to open the current plan’s Archive folder.
- Click **Yes** in the Archived Files dialog when the program warns you that the number of archive files exceeds the **Auto Archive Files** value.

You can also move or delete archived files using your operating system. See your operating system’s Help for more information.

## AUTO SAVE FILES

As you work, Chief Architect automatically creates Auto Save files at regular intervals when changes are made to a file but not saved by selecting **File> Save** .

These Auto Save files are appended **\_auto\_save.plan** or **\_auto\_save.layout** and are saved in the Archive folder.

When you close a file normally, its Auto Save file is retained until the next time the file is opened - at which time the Auto Save file is overwritten.



JonesResidence\_auto\_save.plan

Auto Save file after normal shutdown

You can enable Auto Save and set its frequency in the Preferences dialog. See [File Management Panel on page 104](#).

Auto save files created as a result of an improper program shutdown are appended **\_auto\_save\_bak.plan** or **\_auto\_save\_bak.layout**.





JonesResidence\_auto\_save\_bak.plan

Auto Save file after abnormal shutdown

If your computer shuts down accidentally, you can recover some of your work by opening the **\_auto\_save\_bak** file.

When you reopen a file after a computer shut down or system crash, the program will notify you if an Auto Save file newer than the original file is found and give you the option to open that file.

Even with Auto Save, you should save your work manually on a regular basis using any of the following methods:

- Click the **Save**  button.
- Select **File> Save** .
- Press Ctrl + S on the keyboard.

---

## Opening and Importing Files



Opening and importing files are often similar tasks, but accomplish two very different things:

- Opening a file refers to opening it in the program in which it was created. Only plan or layout files can be opened in Chief Architect. See [Compatibility with Previous Versions on page 35](#).
- Importing a file brings data that was created in a different program into Chief Architect. A number of different file types can be imported into Chief Architect.

Select **File> Open Plan** to open an existing **.plan** file or **File> Open Layout** to open an existing **.layout** file located on your computer. Chief Architect automatically browses to either the directory last used or to a specific directory, depending on your current Preferences settings. See [New Plans Panel on page 108](#).



Before opening a file located on a removable storage device, server, or other computer on a network, copy it to your local machine's hard drive first.

## OPEN FILE DIALOG

The Open File dialog uses the operating system's file open dialog format, and is also used when importing files. The dialog name may vary, depending on your operating system and the type of file being opened or imported.

A similar Select Folder dialog allows you to select an entire folder of files to import.

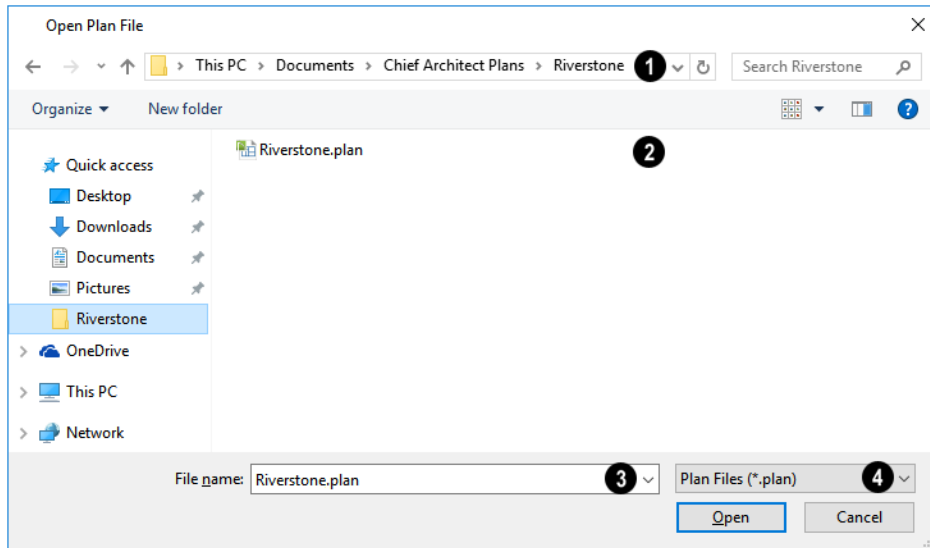

### 1 File Path

Choose the location on your local computer for the file you are opening.

### 2 Folder Contents

Any existing folders and/or files in the current location display here.

### 3 File Name

When selecting a file, its name will automatically display in the **File Name** field. You can also type the file's name to locate a specific file. When importing some types of files, multiple files may be selected.

### 4 File Type

When opening or importing a file, the program will usually choose the appropriate file type from the **File type** drop-down list. When importing, you may need to choose a specific file type.

Plan files open to the floor that was active when the file was last saved and closed; layout files open to the page that was active.

## IMPORTING FILES

Chief Architect has a number of options for exporting and importing information out of and into your drawings. Often, file import dialogs are simply versions of the Open File dialog. See [Importing and Exporting on page 1222](#).

Similarly, file export dialogs are often similar to the Save File dialog. See [Exporting Files on page 41](#).

## RECENTLY OPENED FILES

A list of recently opened and saved plan and layout files can be accessed by selecting **File> Open Recent Files**. Select one of these files to open it without using the Open File dialog.

The maximum number of recent files listed in the **File** menu can be changed in the **Preferences**  dialog. You can also specify that the recent files list display at the bottom of the **File** menu rather than in a submenu. See *File Management Panel on page 104*.

The names of recent files also display in the Dashboard window. Click on the name of a file to open it. See *Dashboard on page 11*.

To clear the Recent Files List, select **File> Open Recent Files> Clear Recent Files**.

## Plan Databases

A Plan Database is a collection of plan files along with search information about those files. You can create one or more Plan Databases and use them to find drawings that you have created that meet a set of search criteria that you specify. See *Searching for Plans on page 48*.

### CREATING A PLAN DATABASE FILE

 Select **Tools> Plan Database> Create Plan Database** to create a new plan database file that can be used to search for plans using the Plan Find Assistant. The Create Plan Database dialog opens.

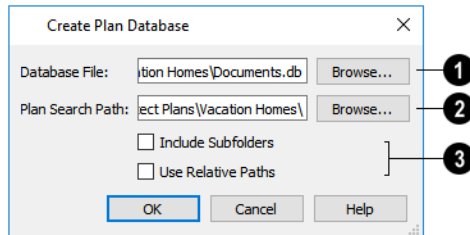

#### 1 Database File

Use the **Database File** field to name the plan database file to be created. Click the **Browse** button to save this file at the location of your choice, as well as name it.

#### 2 Plan Search Path

Specify the **Plan Search Path**, which is the pathname of the folder where plans to be included in the plan database are saved. Any plan files in this folder will be added to the plan database. Click the **Browse** button to navigate to a folder on your computer.

#### 3 Options

- The **Include Subfolders** check box allows you to specify whether the search only looks in the Plan Search Path or if it also searches any subfolders found.

- Check **Use Relative Path** if you anticipate moving the folder containing the database and plans to another location. As long as the database and the plans it references remain in the same folder, that folder can be moved to another location.

When you click **OK**, the program searches for plan files and adds them to the plan database file. The program must read each plan and analyze it so this process may take some time.

You can **Cancel** the search process at any time. If you do, your plan database will have incomplete information and will not contain entries for all plans in your search folder. When all plans have been found and added to the plan database, the program automatically opens the new plan database file for modification.

## EDITING A PLAN DATABASE FILE

 Once a plan database file is created, it can be modified. Select **Tools> Plan Database> Edit Plan Database**, then select the plan database file you want to modify.

Click **OK** to open the Edit Plan Database dialog. You can edit any of the information in the plan database and add and remove plans from the database.

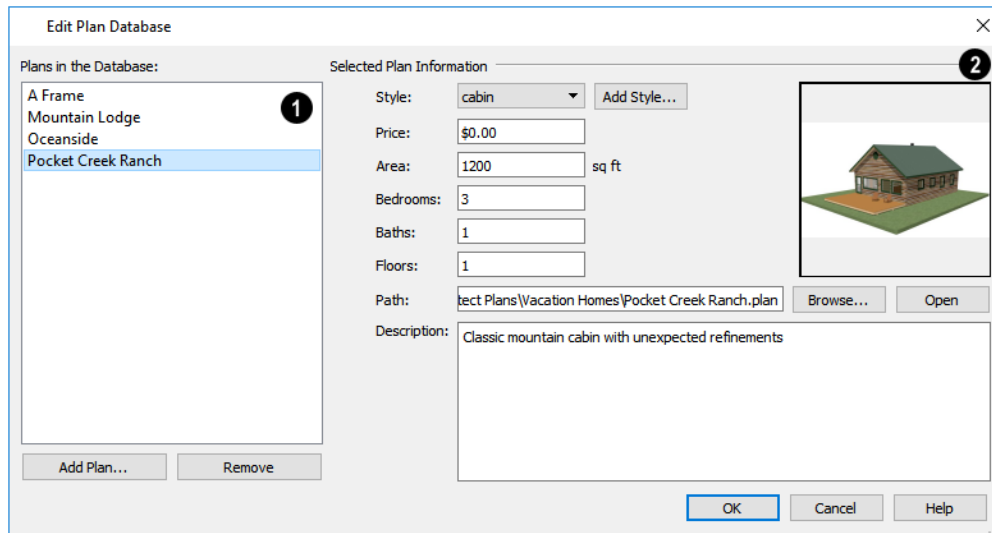

### 1 Plans in the Database

All plans that currently have information stored in the plan database are listed here.

- Click **Add Plan** to select a plan file to add to the plan database.
- Click **Remove** to remove the currently selected plan from the plan database.

### 2 Plan Information

Information about the selected plan displays and can be edited here. This information displays when a plan is found and selected using the **Search for Plans**  tool.

- The Thumbnail preview image of the selected plan displays to the right. See *Thumbnail Images on page 36*.
- Select a plan **Style** from the drop-down list.
- Click the **Add Style** button to add the name of a style to the list.
- Enter the **Price** range for this plan.

- The **Area** is automatically calculated by the program based on the living area of the plan when it is added to the database. You can enter a different value if you wish.
- The number of **Bedrooms** is automatically calculated when a plan is added to the database. You can enter a different number if you wish.
- The number of **Baths** is automatically calculated when a plan is added to the database. You enter a different number if you wish.
- The number of **Floors** is automatically calculated when a plan is added to the database. You can enter a different number of floors if you wish.
- The selected plan file's **Path** name displays here.
- Click **Select File** to relink the selected plan to a file on your computer. If a plan file is renamed, moved, or removed from your system, the plan database will be unable to locate it. You must then relink the plan database to the file or remove it to keep the plan database information accurate.
- Click **Open Plan** to open the selected plan. Opening a plan closes the Plan Database dialog. If you have not saved any changes you made before clicking the **Open Plan** button, you are asked to do so before you continue.
- Enter a **Description** for the plan, if desired.

---

## Searching for Plans



Select **Tools> Plan Database> Search for Plans** to open the Find Plan Assistant, which helps you search specific plan database files based on search parameters that you define.

At the bottom of each page, the number of plans that match your current search parameters displays. As you modify the parameters, this number increases or decreases as matching plans are found. If this number is zero, the **Next** button will be disabled.

On any page, click the **Back** button to modify any previously selected parameters.

### FIND PLAN ASSISTANT

The Find Plan Assistant can be used to search for plans using stored information about each plan, such as the style of construction and the number of bedrooms and other room types.

When you open the Find Plan Assistant, choose a plan database to search. Click the **Browse** button to select a plan database. Once a plan database is selected, click **Next** and proceed through the Find Plan Assistant.



## HOUSE STYLE

The screenshot shows a dialog box titled "Find Plan Assistant" with a close button (X) in the top right corner. Below the title is the section "House Style" with the instruction "Choose the style, number of floors, and number of bedrooms that you would like in your house." The dialog contains four numbered callouts: 1. "What style of home plan would you like? Choose All Styles if you are unsure." with a dropdown menu set to "All Styles". 2. "How many floors do you want in your house?" with a dropdown menu for "No more than:" set to "3". 3. "How many bedrooms do you need in your house?" with two dropdown menus: "At Least:" set to "0" and "But no more than:" set to "4". 4. "5 plans match your search." At the bottom are four buttons: "< Back", "Next >" (highlighted with a blue border), "Cancel", and "Help".

### 1 Style

Select a style of house from the drop-down list.

### 2 # of Floors

Specify the maximum number of floors that you would like.

### 3 # of Bedrooms

Specify the minimum and maximum number of bedrooms that you would like.

### 4 Matches

The number of plans in the database that match your search parameters thus far displays here for reference.

Click Next to continue.

## HOUSE SIZE

The screenshot shows a dialog box titled "Find Plan Assistant" with a close button (X) in the top right corner. Below the title is the section "House Size" with the instruction "Choose the number of bathrooms and size that you would like for your house." The dialog contains four numbered callouts: 1. "How many bathrooms do you want?" with two dropdown menus: "At Least:" set to "0" and "But no more than:" set to "2". 2. "How big of a house do you want?" with two dropdown menus: "At Least:" set to "0" sq ft and "But no more than:" set to "2500" sq ft. 3. "Price Range:" with two text input fields: "Minimum:" set to "\$0.00" and "Maximum:" set to "\$0.00". 4. "5 plans match your search." At the bottom are four buttons: "< Back", "Next >" (highlighted with a blue border), "Cancel", and "Help".

**1 # of Bathrooms**

Specify the minimum and maximum number of bathrooms you would like.

**2 Size**

Specify the minimum and maximum number of square feet that you would like.

**3 Price Range**

Define a price range by specifying Minimum and Maximum prices.

**4 Matches**

The number of plans in the database that match your search parameters thus far displays here for reference.

Click **Next** to continue.

**PLAN DETAILS**

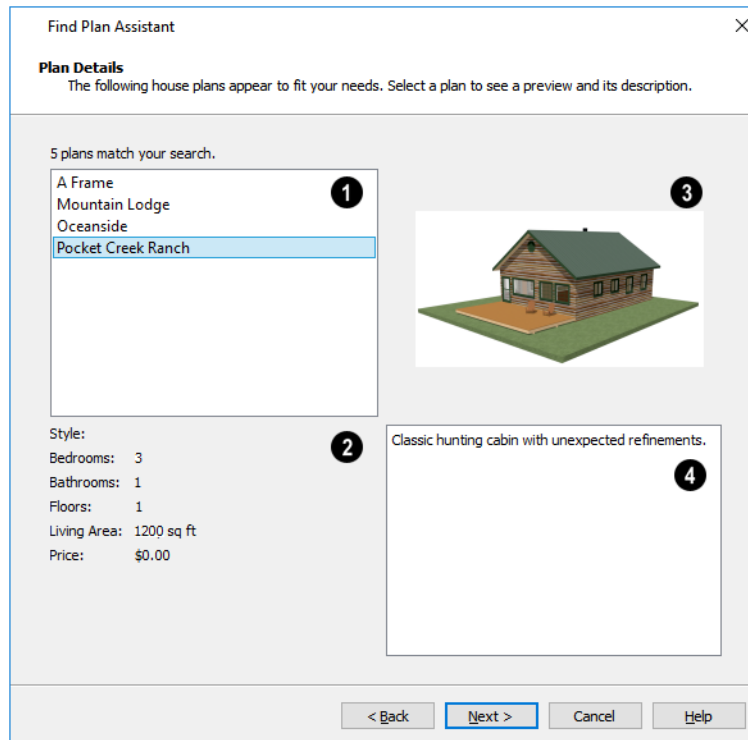

**1 Matches**

Click on the name of a plan to select it and view information about it.

**2 Details**

Basic information about the selected plan display here.

**3 Preview**

A preview of the selected plan displays here.

**4 Description**

A written description of the selected plan provides additional details displays here.

Click **Next** to continue, then click **Finish** to view the selected plan.

## Linked and Referenced Files

A Chief Architect plan or layout file typically includes information from a variety of external files. When an external file is another Chief Architect plan or layout file, the two files are referred to as linked. When the external file is a different file type, it is referred to as a referenced file.

### LINKED FILES

There are several ways in which plan and layout files can be linked to one another:

- Sending views from a plan to a layout file. See *Managing Layout Links on page 1353*.
- Referencing a plan in the Reference Display. See *The Reference Display on page 738*.
- Linking a callout to a view in a different file. See *Linked Callouts on page 524*.

### LINK VIEW DIALOG

The Link View dialog is used when adding a link to a callout or to the Reference Display, or when relinking a layout box to a view.

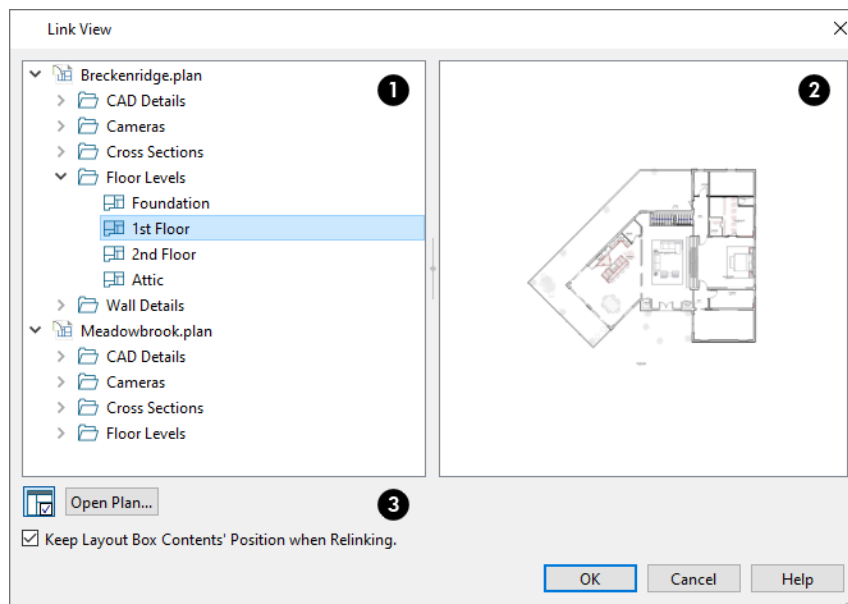

#### 1 Open Files

The names of open plan files display in the tree list. If this dialog was accessed via the Callout Specification dialog, layout files may also be listed.

- Click on a view to select it, then click OK to link the selected object or Reference Display to that view.

#### 2 Preview

A preview of the selected view displays in the pane on the right. Previews can be updated in the **Project Browser**. See *Project Browser on page 58*.

3

- Click the **Show/Hide Preview Panel**  button to toggle the display of the view preview off or on.
- Click the **Open Plan** button to open a plan file not listed above. See *Open File Dialog on page 45*.
- When accessed via the Callout Specification dialog, the **Open Plan/Layout** button is available instead.
- When **Keep Layout Box Contents' Position when Relinking** is checked, the selected layout box will show the same coordinates when it is linked to a new view. When this is unchecked, the contents of the new view will be centered in the layout box. Only available when the Link View dialog is accessed via the Layout Box Specification dialog, and only when a scaled view is linked to another view of the same type.

### REFERENCED PLAN FILES DIALOG

The Referenced Plan Files dialog lists all plan files that the current file is linked to and allows you to relink these files. To open this dialog:



In a plan file, select **Tools> Checks> Referenced Plan Files**.



In a layout file, select **Layout> Referenced Plan Files**.

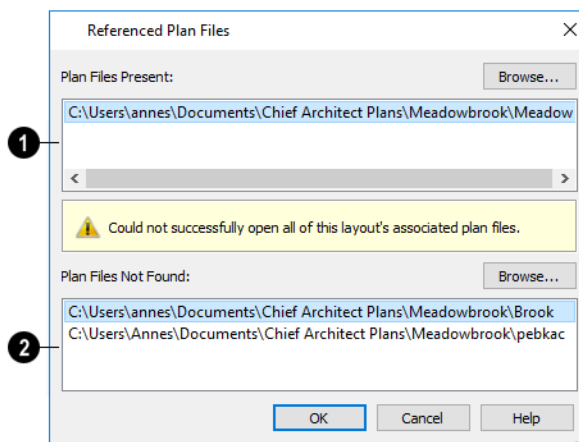

#### 1 Plan Files Present

The names of all plan files with intact links to the current plan or layout are listed here.

If you want, you can select a file and click the **Browse** button just above the **Plan Files Present** field and replace the selected plan with a different plan saved on your system.

#### 2 Plan Files Not Found

The names of all plan files with disrupted links to the current plan or layout are listed here. Any files listed here have been moved, renamed, or deleted and cannot be found by the program. Intervention is required to find these files and reestablish their links to the current file.

Select a missing file and click the **Browse** button just above the **Plan Files Not Found** field to open the Browse For Missing File dialog, which is a typical Open dialog. See *Opening and Importing Files on page 44*.

- Locate the missing file in your system's directory structure. When the missing file is selected, click **Open** to link it to the layout.
- You can also redirect an intact link to from a File Present in Layout to a different file in the same manner.

Be sure to choose **File> Save**  in the layout file when the missing files have been located to save their links to the layout file.

### RESULTS OF MISSING FILES

If all missing files are correctly redefined, the layout opens when you click **OK**.

If an error message displays, one or more of the missing files could not be replaced by the redefined file. Click **OK** to continue. The layout opens, but with the following characteristics:

- Any plan views or CAD Details associated with the missing file(s) are blank. Only the border displays if the "Layout Box Borders" layer is set to display. See [Layout Page Display Options on page 1334](#).
- Any elevations or cross sections associated with the missing file(s) show the automatically generated lines, but any added CAD objects are absent.

### REFERENCED FILES

Chief Architect plan and layout files often reference a variety of external files for added detail, including:

- Material Textures and Maps
- Images
- Plant Images
- 3D Backdrops
- Picture Files
- PDF Files

Whenever any view in a plan or any page in a layout is opened, the program checks for referenced files used in that view and will notify you if any of those files cannot be found by opening the Missing Files dialog.

The Missing Files dialog will also open whenever you Export 3D Model or Export VRML. See [Importing and Exporting on page 1222](#).

If a layout file is missing referenced files on pages that you do not view during the current session, this dialog may also open when you print the layout. See [Layout on page 1333](#).

You can also open this dialog at any time by selecting **Tools> Checks> Missing Files**. When accessed this way, all missing files associated with the current file are listed: not just those used in the current view.

## MISSING FILES DIALOG

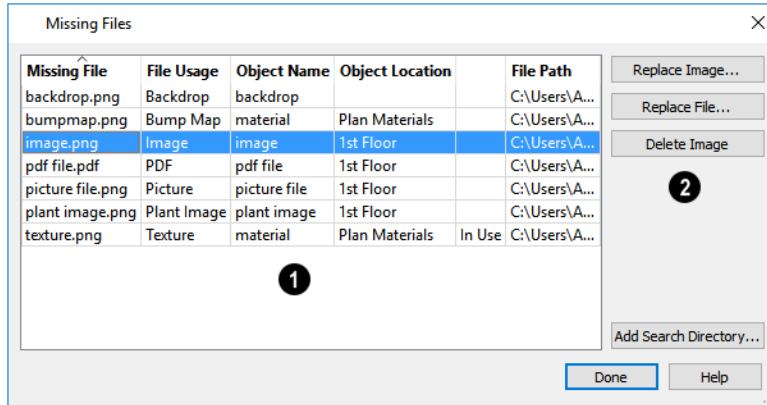

### 1 File Information

The table lists any Missing Files as well as useful information about each:

- **Missing File** reports the name and file extension of the missing file.
- **File Usage** indicates how the missing file is used in the program.
- **Object Name** states the name of the object in Chief Architect that references the file.
- **Object Location** indicates where in the file the object can be found.
- The next column indicates whether a missing texture is in use in the plan.
- **File Path** states the last known location of the missing file on your computer system.

Click on a line item in the table to select it and resolve it using the options on the right. Multiple line items can be selected; however, the selections on the right may be limited. See *Shift and Ctrl Select on page 214*.

### 2 Options

The buttons on the right offer options for resolving a selected missing file. The names of these buttons will vary somewhat, depending on the type of file(s) selected in the list on the left.

- Click the top **Replace Object** button to replace any instances of an object or material referencing the selected missing file with a different object or material from the library. Not available for material maps, PDF files, or picture files.
- Click the **Replace File** button to open the Browse for Missing File dialog and select a file saved on your system to replace the missing one. See *Opening and Importing Files on page 44*.
- Click the **Delete Object** button to remove the object or material referencing the missing file from the plan. Not available for material textures that are In Use.
- Click the Add Search Directory button to direct the program to a particular folder to search for missing files in. The list of Search folders can be reset in the Preferences dialog. See *Reset Options Panel on page 125*.

You can prevent this dialog from opening automatically by checking **Do not display missing files again during this session** at the bottom of the dialog. This option is not available when the dialog is opened manually.

## Backup Entire Plan or Layout



Because Chief Architect plans contain many references to external files such as material textures and images, it is a good idea to make copies all the associated files when a plan is moved to a new location. You can easily do this by selecting **File> Backup Entire Plan**.

Layout files also rely on references to plan files, images, and other files. Select **File> Backup Entire Layout** to copy these files when you want to move a layout file to a new location.

Backing up an entire plan or layout is important when:

- Migrating legacy files created in older program versions.
- Transferring files to another computer or sending them to another user.
- Archiving or backing up your work.

Note: Always use File> Backup Entire Plan or Layout when sending files to a user of the Chief Architect Viewer. See *Sharing Your Files with Clients on page 31*.

### To back up a plan or layout

1. To copy all associated plan or layout files to a new directory, select **File> Backup Entire Plan or Layout**
2. The Backup Entire Plan or Layout dialog opens.

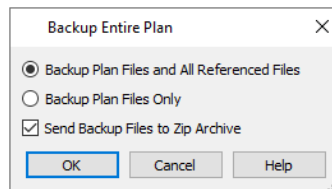

- Choose **Backup Plan Files and All Referenced Files** to copy the plan or layout file and all externally referenced files such as linked plan files, inserted picture files, metafiles, .pdf files, and texture, image, backdrop, and material map files.
  - Choose **Backup Plan Files Only** to copy all associated plan files and any externally linked files and inserted picture files, but no graphics or texture files. This is best used only when transferring a file to a computer that already has the graphics files installed.
  - When **Send Backup Files to Zip Archive** is checked, the files are saved in a zipped folder. Uncheck this if you prefer to save them in a regular folder instead.
  - Click **OK**.
3. The Select the Plan or Project Backup Folder or Choose Zip Archive to Backup dialog opens next. This is a typical Save File dialog. See *Saving, Exporting, and Backing Up Files on page 39*.
    - Navigate to a folder on your system and select it.
    - With the destination folder for the backup selected, click **OK**.
  4. If the destination folder already contains files, the program will confirm whether you want to overwrite them.

The resulting folder contains a copy of the plan or layout file and all referenced files, and can be moved to a new computer.

### **RETURNING VIEWER FILES**

When customers review and annotate files using the Chief Architect Viewer, they only need to return the **.plan** and/or **.layout** files. The associated files do not need to be returned.

---

## **Exiting Chief Architect**

Select **File> Exit** to exit the program. If you have not saved any open files, you will be reminded to do so. It is better to save your work before exiting than to save on exit. See *Closing Views and Files on page 155*.

When you exit from the program using **File> Exit**, all Autosave files and Undo files are automatically deleted. See *Auto Save Files on page 44* and *Undo and Redo on page 289*.

On a Mac, if you click the program window's red **Close** button, the window will close but the program itself will continue to run. To close it down completely, right-click on its icon on the Dock and select **Quit** from the contextual menu.



# Project Planning

## Chapter 3

The tools described in this chapter allow you to conduct preliminary budget and space planning, manage project information and saved views of your projects, and keep track of your time spent working on each file.

### TOPICS

<b>Project Browser</b> .....	<b>58</b>
<b>Time Tracker</b> .....	<b>60</b>
<b>Space Planning</b> .....	<b>62</b>
<b>Room Box Specification Dialog</b> .....	<b>64</b>
<b>Construction Lines</b> .....	<b>65</b>
<b>Construction Line Specification Dialog</b> .....	<b>66</b>
<b>The Reference Display</b> .....	<b>68</b>
<b>Finding Objects</b> .....	<b>72</b>
<b>Plan Check</b> .....	<b>72</b>
<b>Loan Calculator</b> .....	<b>73</b>

# Project Browser



The Project Browser is a convenient way to access all of the saved views, details, and Materials Lists within an open plan and all of the pages saved in an open layout. You can dock it to the top, bottom, or either side of the Chief Architect window or let it float freely. To open the Project Browser, press the select **View> Project Browser**. See *View and Side Windows on page 17*.

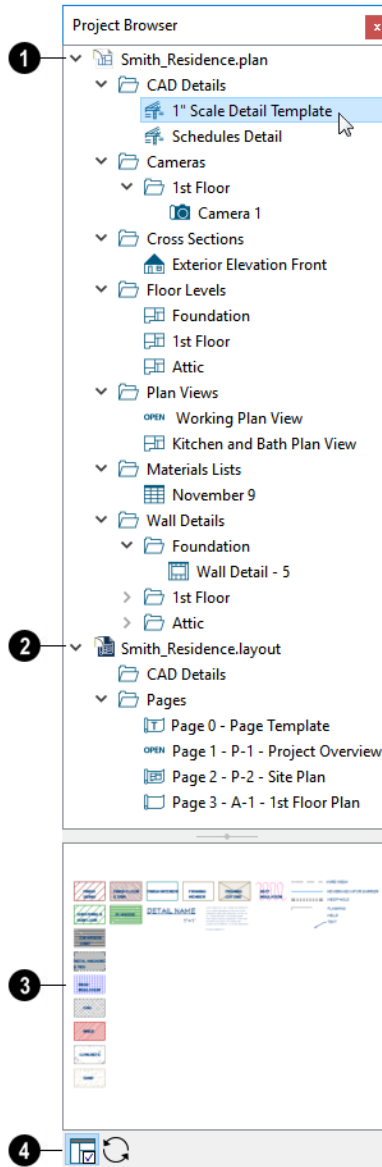



## 1 Plan File



The name of an open plan file displays here, and the views saved in that file are listed below. Click on a view's name to select it; double-click on its name to open the view; right-click on it to access its contextual menu. See *Using the Contextual Menu on page 60*, below.

 **CAD Details** - CAD Details saved in the plan are listed here. See *CAD Details on page 337*.

 **Cameras** - Full and overview cameras saved with the plan are listed here by floor. See *Camera Views on page 1084*

 **Cross Sections** - Cross Section and Elevation views are listed here. See *Cross Section/Elevation Views on page 1085*.

 **Floor Levels** - All users floor plans in the plan are listed here. See *Multiple Floors on page 730*.

 **Materials Lists** - Materials Lists and Reports saved in the plan are listed here. See *Materials Lists on page 1303*.

 **Plan Views** - All saved plan views are listed here. See *Plan Views on page 146*.

 **Schedules** - Any schedule present anywhere in the plan is listed here. See *The Schedule Tools on page 682*.

 **Wall Details** - Framing details for any framed wall will be listed here by floor. See *In Wall Detail Views on page 880*.

Indicates the view is currently open.

OPEN

## 2 Layout File

 The name of an open layout file displays here. See *Layout Page Management on page 1355*.

 **CAD Details** - CAD Detail pages saved with the layout are listed here. See *CAD Details on page 337*.

 **Page Template** - The selected Layout page is set as a Page Template. See: *Layout Page Templates on page 1358*

 **Used Page** - The selected Layout page contains one or more objects.

 **Blank Page** - The selected Layout page is empty, but has otherwise been customized. See *Layout Page Information on page 1358*

 **Tables** - All tables present in the layout file are listed here. See *Layout Page and Revision Tables on page 1361*.

Indicates the view is currently open.

OPEN

## 3 Preview Pane

A preview of the view or layout page selected in the list above displays here. Double-click on the preview to open the selected view or page.

## 4 Toolbar

 **Show/Hide Preview Pane** toggles the Preview Pane on and off.

 **Update Preview(s)** updates the previews for views associated with open plan and layout files.

## USING THE CONTEXTUAL MENU

Items in the Project Browser can be accessed, modified and organized using the contextual menu. To access its contextual menu, simply right-click on a line item. See *Contextual Menus on page 19*.

You can also select multiple line items in the same folder as a group and then right-click to open a shared contextual menu. The options that are available in the menu depend on the type of objects selected. See *Shift and Ctrl Select on page 214*.

- Plan and Layout file level items have **Save Plan**, **Close All Views**, **Save Layout**, **Close Layout**, **Expand All**, and **Collapse All** in their contextual menus.
- All folder level items with contents in them have **Select All**, **Expand All**, and **Collapse All** in their contextual menus.
- All views, floor levels, and pages can be accessed by selecting **Open View** or **Show Page**, respectively. You can also open a view or page by double-clicking on its name or its preview.
- All views, floor levels, and pages have the **Update Preview(s)** option in their contextual menu when selected individually or in groups.
- If a plan view is open, **Save View** will be an option in its contextual menu. Similarly, if a camera is open, **Save Camera** will be among its options.
- An open a view can be closed by selecting **Close View** from the contextual menu.
- Plan Views and CAD Details have specification dialogs that can be accessed by selecting **Edit View**. See *Plan View Specification Dialog on page 148* and *CAD Detail Specification Dialog on page 338*.
- Layout pages have an **Edit Page Information** option. See *Layout Page Information Dialog on page 1359*.
- Plan Views, camera views, and most CAD Details have the **Send to Layout** option. See *Sending Views to Layout on page 1338*.
- All views aside from Floors and layout Pages can be **Renamed**.
- Plan Views, CAD Details, and layout Pages can be **Duplicated**.
- All views aside from Floors and layout Pages specified as Templates can be **Deleted**. See *Page Templates on page 1334*.
- New Pages can be **Inserted Before** or **After** a selected layout Page. Layout Pages can be **Exchanged**, as well.
- Schedules and Layout Tables have a **Find in Project** option. See *Finding Objects on page 211*.
- A **New Saved Plan View** can be created in the Plan Views folder for plans and layouts.
- A **New CAD Detail** can be created in the CAD Details folder for plans and layouts.

---

## Time Tracker



The **Time Tracker** tool monitors the time spent on each Chief Architect file. You can enter start and end times each time a plan or layout file is opened and closed, or allow it to run automatically. The Time Tracker keeps a log that can be amended and edited as needed. You can control how **Time Tracker** functions, including its timeout period, in the Preferences dialog. See *Time Tracker Panel on page 112*.

Time Tracker information is stored with each file and can be printed or exported from the Time Log dialog.



Select **Tools> Time Tracker> Start Time Logging** to begin logging time for the current plan or layout file. This creates a new entry. Opening a plan or layout automatically starts a time log if you set your preferences to do so. See *Time Tracker Panel on page 112*.



Select **Tools> Time Tracker> Stop Time Logging** to stop logging time for the current file. Only available when an entry is currently being recorded.

 Select **Tools> Time Tracker> View Time Log** to open the Time Log dialog and view the time log for the current file.

 Time Tracker logs times for each plan and layout file separately, even if they have the same project name or are saved in the same directory on your computer.

## TIME LOG DIALOG

 The Time Log dialog displays all entries logged for the current plan or layout file. Entries can be added, deleted, edited, exported, and printed.

Select **Tools> Time Tracker> View Time Log** to open the Time Log dialog.

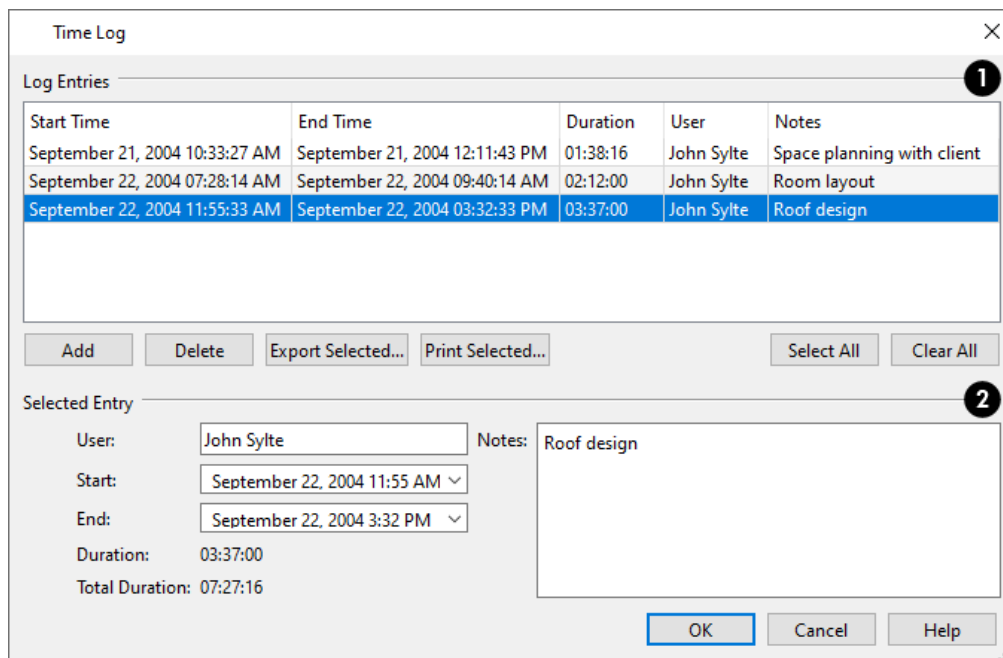

### 1 Log Entries

The current plan or layout file's **Log Entries** displays here. Entries are listed in the order they were created. Click in a row to select that entry. Multiple rows can also be selected. See [Shift and Ctrl Select on page 214](#).

- Click the **Add** button to add a new entry using the current time as the Start Time.
- Select one or more entries and click the **Delete** button to remove it from the current file.
- Select one or more entries and click the **Export Selected** button to open the Save Time Log dialog and specify a name and destination for the exported file. Time log information can be exported as either a text (.txt) or Comma Separated Values (.csv) file. See [Exporting Files on page 41](#).
- Select one or more entries and click the **Print Selected** button to open the Print dialog and print the selected entries. To print the entire log, click the **Select All** button before printing. See [Print View Dialog on page 1380](#).
- Click the **Select All** button to select all entries in the list as a group, or click the **Clear All** button to unselect all entries.

### 2 Selected Entry

These settings let you modify the entry selected in the list above. When multiple entries are selected, only the User and

Notes can be modified.

- The name of the software **User** that created each entry can be specified here. The Default User Name can be set in the Preferences dialog; if no Default User Name is specified, this field will be blank by default. See *Time Tracker Panel on page 112*.
- The **Start** and **End** times can be edited by typing new values in the text fields. You can also click the drop-down list and select a date from the calendar. The Start time must predate the End time. See *Region and Language Settings on page 78*.
- The **Duration** of the selected entry and the **Total Duration** display for reference.
- **Notes** about the selected entry can be typed into the text field on the right.

## Space Planning

 The **Space Planning Tools** are a time-saving way to create a preliminary room-by-room design of a home without getting caught up in the details. When the room boxes are laid out, the **Build House** tool converts them into a working plan that can be edited and detailed to completion.

### SPACE PLANNING ASSISTANT

In plan view, select **Tools> Space Planning> Space Planning**. The Space Planning Assistant gathers information about the rooms you want to include in your house. When you click **Finish**, the selected room boxes display.

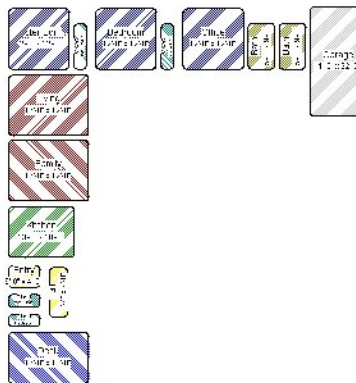

Room boxes can now be arranged into a floor plan.

Note: Each Bedroom called for in the Space Planning Assistant also produces a Closet.

### PLACING ROOM BOXES







In addition to or as an alternative to the room boxes created for you by the Space Planning Assistant, you can create your own room boxes. In plan view, select **Tools> Space Planning** , choose the desired room type from the submenu, then click to place a room box of that type.

### DISPLAYING ROOM BOXES

Room boxes and their labels are located on the “Space Planning Boxes” layer. Space Planning Box labels use the Text Style assigned to that layer, as well. See *Displaying Objects on page 176*.

## EDITING ROOM BOXES

Once created, room boxes can be edited in a variety of ways.

- Select room boxes using the **Select Objects**  tool just like other objects in Chief Architect. See *Selecting Objects on page 210*.
- Room boxes can be resized, rotated, and rearranged. See *Editing Box-Based Objects on page 232*.
- When arranging room boxes, make sure **Object Snaps**  are enabled so their edges snap to one another. See *Object Snaps on page 160*.
- Rooms can be overlapped: when this is the case, the room box edges drawn in front will be converted to walls when the **Build House**  tool is used. By default, smaller rooms draw over larger rooms; however, you can control their drawing order. See *Drawing Groups on page 190*.
- Rooms can be copied and pasted using the **Copy/Paste**  edit button and deleted using the **Delete**  edit button.
- Select **Tools> Space Planning**  or click the **Space Planning Configuration**  button to access the room box tools and place additional room boxes in your plan. Select a tool and click in the plan to place a room box of that type.

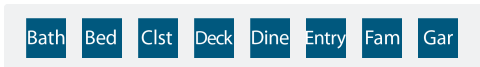

- Select **Tools> Space Planning> Toggle Room Boxes**  or click the toggle button to hide or show the room boxes.

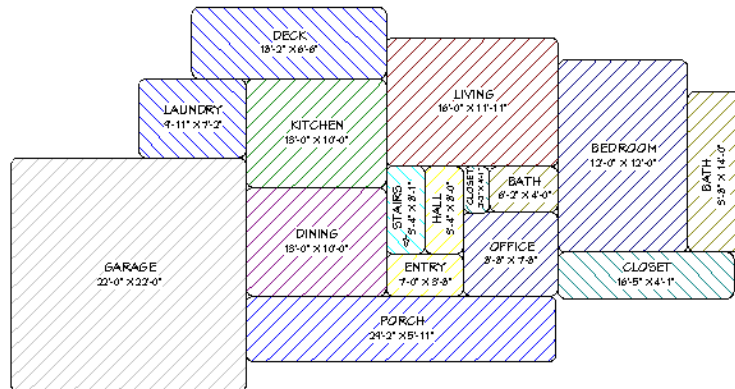

## BUILD HOUSE

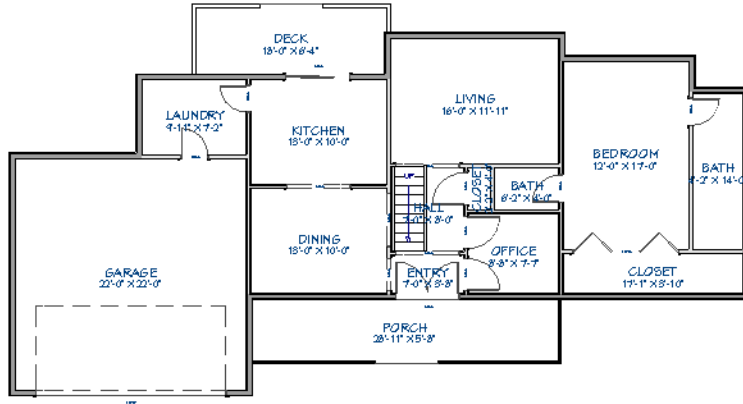

- When the room boxes are in place, select **Tools> Space Planning> Build House** to convert them into a building composed of walls and railings. Doors are inserted between the rooms, as well.



When you Build House, the “Space Planning Boxes” layer is automatically turned off. The room boxes that you created are not deleted, however.

## MULTIPLE FLOORS

If you specified a two-story house in the Space Planning Assistant:

1. Edit and arrange the room boxes on Floor 1 as desired.
2. Select **Tools> Space Planning> Build House**  tool to create the walls on the first floor.
3. Go **Up One Floor**  and notice that the positions of the walls on Floor 1 display in red as a reference.
4. Arrange the rooms on Floor 2 as desired using the red polylines as a guide.
5. On the second floor, select **Tools> Space Planning> Build House**  to complete the second floor.

## Room Box Specification Dialog

 Select one or more room boxes and click the **Open Object** edit button to open the Room Box Specification dialog. See [Space Planning on page 62](#).

### GENERAL PANEL

Most of the settings on the GENERAL panel are used when the selected room box is converted to a room using the **Build House**  tool.

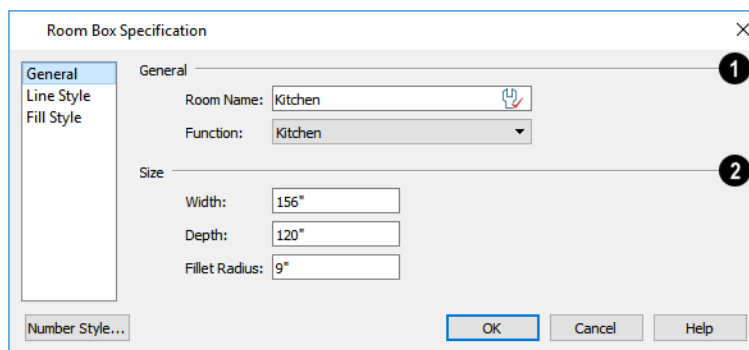



## 1 General

Specify the selected room box's **Room Type and Name**.

- Specify a **Room Name** for the selected room box. When the default is specified, the Function selected below is used as the name.
- Select a **Function** from the drop-down list. See *Room Types and Functions on page 415*.

## 2 Size

Specify the **Size** of the selected room box.

- Specify the room box's **Width** and **Height**.
- Specify the **Fillet Radius**, which is the radius of the curve on each of the room box's corners. Unlike the other settings on this panel, this value does not affect the shape of the room created using **Build House** .

## LINE STYLE PANEL

The LINE STYLE panel is available for a variety of other objects in the program. For more information, see *Line Style Panel on page 305*.

## FILL STYLE PANEL

The FILL STYLE panel is available for a variety of other objects in the program. See *Fill Style Panel and Dialogs on page 193*.

---

# Construction Lines

 The **Construction Line** tool allows you to create guide lines to help locate features of a design and ensure that objects are correctly aligned. In a plan view or cross section/elevation view, select **CAD> Line> Construction Line**, then click and drag to draw a line. See *Line Tools on page 300*.

Construction Lines can be drawn at various angles, can snap to other objects, and can be replicated. See *Snap Behaviors on page 159*.

Once drawn, a Construction Line can be edited in a variety of ways using its edit handles, edit tools, and specification dialog. See *Construction Line Specification Dialog on page 66*.

Once in place, Construction Lines can be used to align objects in a variety of ways:

- CAD and architectural objects can snap to Construction Lines.
- Dimension lines can locate them. See *Dimensions on page 448*.
- Edit tools such as Center Object and Make Parallel/Perpendicular work with them. See *Aligning Objects on page 246*.
- The Trim Object(s) and Extend Object(s) edit tools work with them. See *Trim and Extend on page 272*.

## DISPLAYING CONSTRUCTION LINES

Construction Lines are placed on the "Construction Lines" layer by default and are included in printed views and views sent to layout when this layer is turned on. You can place Construction Lines on custom layers as needed for different purposes. You can also lock their layer to prevent Construction Lines from being selected while you are working. See *Layers on page 176*.

Construction Lines can display callouts on either or both ends. They can also display as the length they are drawn, or of infinite length. Infinite-length lines are not included in the view extents, and if they have callouts specified, these are always visible at the edges of the view. See [Construction Line Panel on page 66](#).

By default, Construction Lines are placed in Drawing Group 21, with other CAD objects. You can place them in a different group if you prefer, so that they display in front of or behind other objects in plan view to suit your needs. See [Drawing Groups on page 190](#).

## IN PLAN AND CROSS SECTION/ELEVATION VIEWS

Unlike other CAD objects, Construction Lines can display in both plan views and cross section/elevation views under certain conditions.

- A Construction Line may be set to **Display on All Floors in Plan View**, or only on the floor level where it was drawn.
- If a Construction Line is drawn in plan view, it can display in any cross section/elevation view with a line of sight that is parallel to it, regardless of whether it is set to Display on All Floors in Plan View, and regardless of which floor level the view is on.
- If a Construction Line is drawn vertically in a cross section/elevation view, it can display in plan view.

---

## Construction Line Specification Dialog

To open the Construction Line Specification dialog, select a Construction Line and click the **Open Object** edit button. See [Construction Lines on page 65](#).

The Construction Line Specification dialog is similar to the Construction Line Defaults dialog but affects the selected Construction Line rather than all subsequently created Construction Lines.

### CONSTRUCTION LINE PANEL

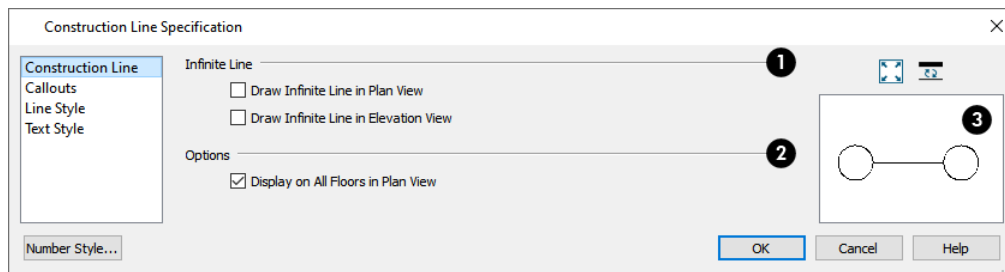

#### 1 Infinite Line

Infinite Construction Lines do not affect the extents of any views they display in.

- Check **Draw Infinite Line in Plan View** to display the selected Construction Line as infinite in length in plan views.
- Check **Draw Infinite Line in Elevation View** to display the selected Construction Line as infinite in length in cross section/elevation views.

## 2 Options

- When **Display on All Floors in Plan View** is checked, the selected Construction Line displays on all floor levels in the current plan. Uncheck this to display it only the floor level where it was drawn in plan view. This setting does not affect the Construction Line's display in cross section/elevation views. See *Multiple Floors on page 730*.

## 3 Preview

A preview of the selected Construction Line displays on the right. See *Dialog Preview Panes on page 22*.

## CALLOUTS PANEL

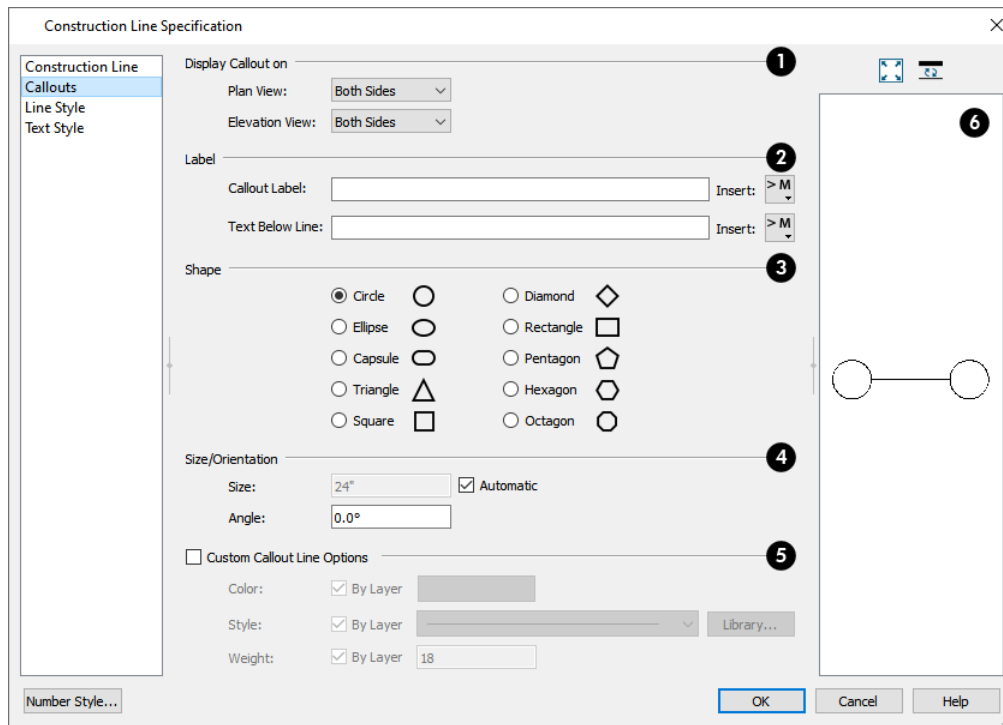

## 1 Display Callout on

Specify the use of callouts in **Plan View** and, separately, in **Elevation View**. See *Selected Edge on page 212*.

- Select **Both** for callouts on both ends of the selected Construction Line.
- Select **Start** for a callout on the line's Start point only.
- Select **End** for a callout on the line's End point only.
- Select **None** for no callouts on either end.

## 2 Label

Specify the text you would like inside the selected Construction Line's callout(s).

- Type the **Callout Label**, which displays inside the callout shape. This text is centered in the callout when no Text Below Line is specified.

- Type the **Text Below Line** for the bottom row, if desired. If Text Below Line is added, a line centered in the callout shape will separate this text from the Text Above Line.
- Click the **Insert** button to the right of either Text option to choose from a list of special characters and text macros. See *Text Macros on page 540*.

### 3 Shape

Select a callout shape by clicking the radio button beside one of the options.

### 4 Size/Orientation

- Uncheck **Automatic** to enable the **Size** field and specify a new value. When checked, the callout is sized so that it encompasses its Label.
- Specify the **Angle** of the callout shape(s). Not available for Ellipse, Capsule, or Rectangle shaped callouts.

### 5 Custom Callout Line Options

When this box is unchecked, the callout shapes are outlined using the same attributes as the Construction Line between them. Check this box to enable the settings that follow and outline the callouts using custom attributes.

- Click the **Color** bar to choose a color for the callout shape outlines in the Select Color dialog. See *Color Chooser/Select Color Dialog on page 203*.
- Select a **Line Style** for the callout shape outlines from the drop-down list or click the **Library** button to select a line style from the library. See *Line Styles on page 199*.
- Specify the **Line Weight**, or thickness, for the callout shape outlines. See *Line Weights on page 1374*.
- Check the **By Layer** box beside any of these options to use the attribute assigned to the selected Construction Line's layer.

### 6 Preview

A preview of the selected Construction Line displays on the right. See *Dialog Preview Panes on page 22*.

## LINE STYLE PANEL

The LINE STYLE panel is found in the specification dialogs for many different objects. See *Line Style Panel on page 305*.

## TEXT STYLE PANEL

The settings on the TEXT STYLE panel control the appearance of the selected object's text. See *Text Style Panel on page 538*.

---

# The Reference Display

Objects on the Current Floor can snap to objects on the Reference Floor; however, objects on the Reference Floor cannot be selected or edited.

The Reference Display allows you to show the positions of objects on a different floor or even in a different plan file in the current view. This allows you to confirm correct placement of objects; show an as-built structure in the same view as a remodel drawing; compare different options; and more. The Reference Display can be used in plan, camera, and cross section/elevation views.

## REFERENCING A FLOOR PLAN

In plan view, the Reference Display can show one or more Reference Floors from the current plan or from another plan file or files.

- By default, the current plan file is used, the Reference Floor is the floor below the Current Floor, and the Reference Display uses the “Reference Display Layer Set”.
- If you specify that the Reference Display refer to another plan file, it will show the same floor level as the current plan by default, if possible, and will use the “Reference Display Layer Set” as defined in that other plan file.

While the default “Reference Display Layer Set” is sufficient for most purposes, you can create additional reference layer sets and use any of them individually or in combination in the Reference Floor Display. See [Layer Set Management on page 184](#).

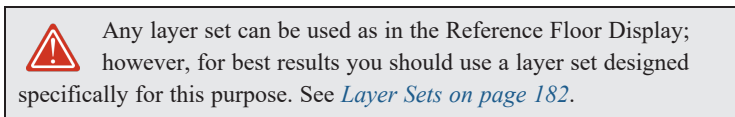

Reference Floor Display settings, including whether its display is toggled on, which floor level or levels are shown, and which layer set or sets it uses, are plan view specific and can be customized in the Saved Plan View Specification dialog. See [Layout Box Specification Dialog on page 1349](#).

These settings can also be customized in plan views sent to layout. See [Layout Box Specification Dialog on page 1349](#).

## REFERENCING A 3D MODEL

In camera and cross section/elevation views, the Reference Display can show objects from another plan file, as well as specify whether they are shown using Standard or Glass House Rendering.

In camera and cross section/elevation views, the default layer set for the current view type as set in the current plan is used. The actual layer set is saved in the referenced plan, and can be changed to use any other layer set saved in that plan. See [Layer Set Management on page 184](#).

## CHANGE FLOOR / REFERENCE DIALOG

- 1 Select **Tools> Floor/Reference Display> Change Floor/Reference** or click the toolbar button that reports the current floor level. See [The Current Floor on page 737](#).

In the Change Floor/Reference dialog, you can specify which floor level is the Current Floor. You can also specify a Reference Floor from one or more different plan files, multiple Reference Floors, and Reference Floor layer sets and drawing order here, as well.

When this dialog is accessed from a camera view, the Reference Display settings instead allow you to specify one or more referenced plan files, layer sets, and Rendering Techniques.

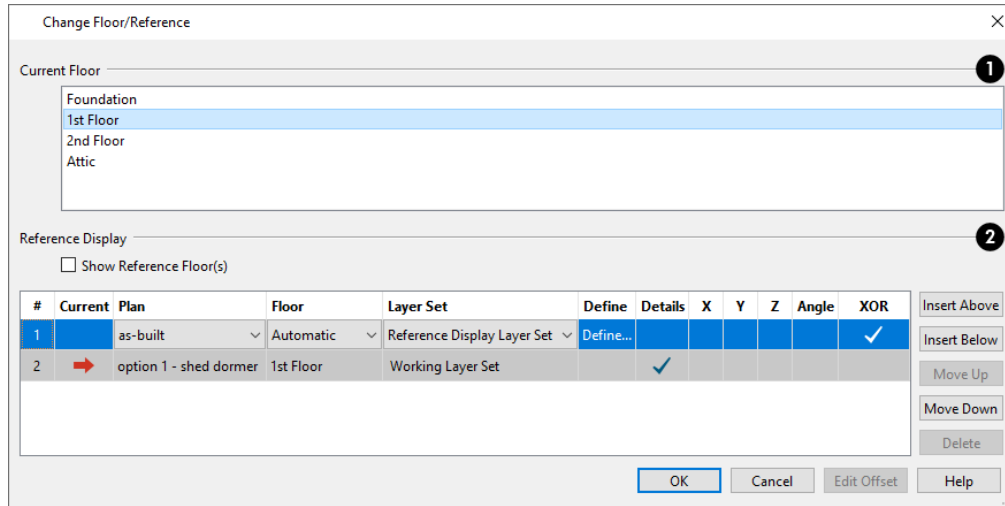

### 1 Current Floor

The **Current Floor** is highlighted here. Select another floor from the list to make it the Current Floor instead.

### 2 Reference Display

These settings control the display and appearance of the Reference Floor or Reference Model in the current plan, camera, or cross section/elevation view.

- Check **Show Reference Floor(s)** to turn on the Reference Floor Display in the current plan view. When a camera view is active, this option is instead **Show Reference Model(s)**.
- The table lists the Current Floor or Plan along with one or more Reference Floors or Models in the order that they are drawn. Line items at the top of the table are drawn in front of line items further down in the table.
- Click on a line item in the table to select and edit it. Items with an arrow on the right side are drop-down lists.
- In plan view, the **Current** column indicates which line item in the table is either the Current Floor, selected above, or the currently active plan file. In camera and cross section/elevation views it indicates which line item is the Current Plan. The Current line item's attributes cannot be edited in this table.
- In all views, you can select a **Plan** file to show in the Reference Display.
- In plan view, the default plan is the Current Plan; in camera and cross section/elevation views, a different plan must be selected for use as the Reference Model.
- All currently open plan files are listed in the drop-down list.
- Select "Choose Existing Plan" to choose any available plan file. If it is not currently open, it will be opened when you select it.

- In plan view only, specify which **Floor** level is associated with each line item.
- The floor levels in the drop-down list are listed in the order that they are drawn in plan view: The floor in row 1 is drawn on top of the floor in row 2, which is drawn on top of the floor in row 3, and so on. Drawing order can be edited using the buttons to the right of the table.
- When “Automatic” is selected, the floor level below the Current Floor is always used; if there is no floor below, the floor above is used instead. If you instead choose a specific floor level from the list, it will be used, regardless of which floor level is the Current Floor. Not available for camera or cross section/elevation views.
- When a plan other than the Current Plan is selected for reference, "Match Current" is the default option that ensures that the Current Plan and Reference Plan always show the same floor level.
- Specify which **Layer Set** each line item uses. See [Layer Sets on page 182](#).
- Click in the **Define** column to open the Layer Display Options dialog and edit the Layer Set assigned to the selected line item. Not an option for the Current Floor level or Current Plan.
- In camera views, specify which **Rendering Technique** each referenced plan uses. Select Standard, Glass House, Technical Illustration, or Vector View from the drop-down list. See [Rendering Techniques on page 1150](#).
- Click to place a check in the **Details** column and include fill patterns in the Reference Floor Display. When unchecked, only object edge lines are drawn. Details are always included in the Current Floor.
- When a different plan has been selected for a Reference Plan, you can:
  - Offset it along the **X**, **Y**, and **Z** axes to bring it into alignment with the Current Plan. See [3D Drafting on page 13](#).
  - Specify the Reference Plan's **Angle**. See Edit Reference Document Offset, below.
- **XOR** drawing changes the color of lines in the Reference Floor Display when they are drawn on top of lines on the Current Floor. If the lines have identical properties, they are not drawn at all. When this is unchecked, the Reference Display color does not change, and identical lines are not suppressed.

Use the buttons on the right to manage the list of Reference Floors in the table. New Reference Floors use the Automatic floor behavior and Reference Floor Layer Set by default.

- Click the **Insert Above** button to add a new Reference Floor directly above the selected line item.
- Click the **Insert Below** button to add a new Reference Floor directly below the selected line item.
- Click the **Move Up** button to move the selected line item up one place in the list and in the display order.
- Click the **Move Down** button to move the selected line item down one place in the list and in the display order.
- Click the **Delete** button to remove the selected Reference Floor from the list. Not available if only one Reference Floor is present in the list, or if the Current Floor is selected.





## EDIT REFERENCE DOCUMENT OFFSET



When a different plan has been specified for the Reference Display, you can select **Tools> Floor/Reference Display> Edit Reference Document Offset** to toggle on the display of a selection marquee around it. The marquee has two edit handles: Move, and Rotate. The Move handle lets you adjust the **X** and **Y** offset, while the Rotate handle allows you to change the **Angle**.

## Finding Objects

There are a variety of tools in the program designed to help you locate specific objects. These tools often open a new view window in which the object in question is either highlighted or selected.

- To find out where a line item in a schedule or the Materials List is located in the model, select its row or any cell in its row and click the **Find Object in Plan**  edit button. See [Find Object in Plan on page 691](#).
- To locate a string of text, select **Edit> Find/Replace Text**. See [Find/Replace Text on page 516](#).
- To find objects that are similar to a selected object in the current view, click the **Match Properties**  edit button. See [Matching Properties on page 282](#).
- In a Wall Detail, Framing Overview or other 3D view in which wall framing can be seen, select a wall framing member and click the **Find Wall**  edit button to locate its owner wall in plan view. See [Selecting Walls on page 368](#).
- In the Truss Detail, select a truss and click the **Find Trusses**  edit button to switch to a plan view in which the truss is selected. See [Truss Details on page 901](#).
- In the Project Browser, right-click on a schedule or Layout Table and select **Find in Project** from the contextual menu. The view in which the schedule is located opens, if necessary, and the schedule or table is selected. See [Project Browser on page 58](#).

Additional tools are available to help you find files referenced by your plans and layout files.

- Select **Tools> Checks> Missing Files Check** to identify and locate any missing referenced files. See [Linked and Referenced Files on page 51](#).
- Select **Tools> Layout> Referenced Plan Files** to identify and locate any plans linked to the current layout file. See [Managing Layout Links on page 1353](#).

## Plan Check



**Plan Check** examines the current floor of a plan, checking for anything that appears to violate common building practices. Plan Check may not find all the problems in a plan, but does it point out areas that may need improvement.



Disclaimer: The Plan Check feature in Chief Architect does not claim to detect all building code and design requirements. It merely compares your plan with common building practices.

To run Plan Check, select **Tools> Checks> Plan Check** .

Potential plan errors found are usually highlighted in plan view. To ensure the highlighted item is on-screen, make sure the entire plan is shown in the window before you run **Plan Check**.



## PLAN CHECK DIALOG

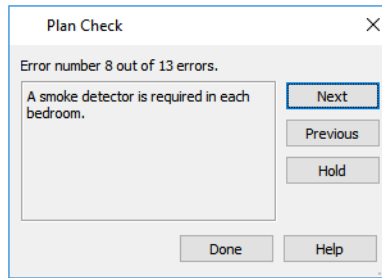

The current error number, along with the total number of errors found, is stated at the top of the dialog.

A description of the current error displays in the field on the left.

Options for navigating Plan Check are found on the right side.

- Click **Next** to ignore the current error and proceed to the next.
- Click **Previous** to return to the previous error.
- Click **Hold** to suspend Plan Check so you can fix the current error. Select **Tools> Checks> Plan Check** again and the check starts where it left off.
- Click **Done** to terminate Plan Check.

If this dialog obscures the plan view, drag its title bar to move it. It remembers its new position and displays there the next time **Plan Check** is run.

## ROOM TYPES

**Plan Check** can do a much better job of checking for problems if it knows what the rooms in your plan are to be used for, so you should assign a Room Type to each room in your plan. See [Room Types and Functions on page 415](#).

The first time **Plan Check** runs in a plan, it automatically assigns a room type to as many undesignated rooms as it can. Some rooms are determined by their size and shape, and others by their contents. For example, a shelf in a small room indicates a closet; a stove or refrigerator indicates a kitchen; or a bed, a bedroom. If the program cannot assign a room type, **Plan Check** highlights it and suggests that you do so manually.

---

## Loan Calculator



Select **Tools> Loan Calculator** to open the Loan Calculator dialog. This dialog lets you calculate different aspects of a loan for the current plan based on a variety of parameters.

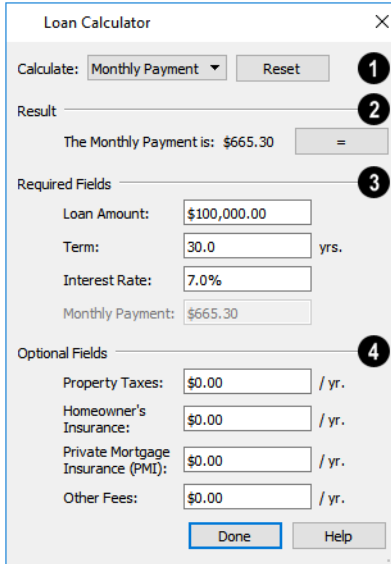

### 1 Calculate

Specify what aspect of the loan you would like to calculate from the **Calculate** drop-down list:

- Monthly Payment
- Loan Amount
- Term
- Interest Rate

### 2 Result

The calculation **Result**, based on the information you provide, displays here.

- If you make changes to any of the fields in the dialog, click the = button to refresh the **Result**.

### 3 Required Fields

The **Required Fields** are the same as the options in the **Calculate** drop-down list. The option selected under **Calculate** will be inactive under **Required Fields**.

- Specify the desired **Loan Amount**.
- Specify the desired **Term**, in years.
- Specify the desired **Interest Rate**.
- Specify the desired **Monthly Payment**.

### 4 Optional Fields

The **Optional Fields** allow you to include additional information in your loan calculation.

- Specify the expected **Property Taxes** per year.
- Specify the expected **Homeowner's Insurance** cost per year.

- Specify the expected **Private Mortgage Insurance (PMI)** cost per year.
- Specify the cost of any expected **Other Fees**.

When Monthly Payment is calculated, each Optional value is divided by twelve (months) and then added to the total payment.

When a Calculate option other than Monthly Payment is selected, these values are divided by twelve (months) and then subtracted from the specified Monthly Payment value. The result, which does not display, is then used to determine the Loan Amount, Term or Interest Rate.

# Preferences and Default Settings

## Chapter 4

Preferences are global settings that affect the functionality and appearance of the Chief Architect environment, while default settings control what objects look like when they are initially created. You can save time and increase your productivity by becoming familiar with these settings and customizing them before you begin a new project or as needed thereafter.



If you regularly use the same customized settings, it is a good idea to save them in a template plan. See *To create a plan template on page 89*.

### TOPICS

<b>Default Settings vs Preferences</b> .....	<b>77</b>
<b>Dynamic Defaults</b> .....	<b>79</b>
<b>Set as Default</b> .....	<b>79</b>
<b>Multiple Saved Defaults</b> .....	<b>79</b>
<b>Active Defaults Dialog</b> .....	<b>82</b>
<b>Default Sets</b> .....	<b>83</b>
<b>Exporting and Importing Default Sets</b> .....	<b>86</b>
<b>Template Files</b> .....	<b>87</b>
<b>Importing Default Settings</b> .....	<b>90</b>
<b>Reset to Defaults</b> .....	<b>91</b>
<b>General Plan Defaults Dialog</b> .....	<b>92</b>
<b>Preferences Dialog</b> .....	<b>95</b>
<b>Dialog Number/Angle Style Dialog</b> .....	<b>126</b>

## Default Settings vs Preferences

Default and preference settings have important effects on how the tools in Chief Architect function. Default settings are file specific, while Preferences are global, taking effect regardless of what file is open.

Defaults and Preferences can be customized to suit your needs and improve your efficiency, so it is recommended that you become familiar with them and learn how you can use them to your advantage.

### DEFAULT SETTINGS

 Default settings determine the initial characteristics of objects when they are first drawn. For example, when you place a base cabinet in a plan, its size, materials, front items, and hardware are determined by settings in the Base Cabinet Defaults dialog.

Some defaults affect the structure of your model: for example, Floor, Foundation, Framing, and Wall defaults.

Defaults are file-specific, which means that any changes that you make to the default settings in one plan or layout file will have no effect on other plans or layout files. You can, however, import the defaults settings saved in one plan file into another. See [Importing Default Settings on page 90](#).

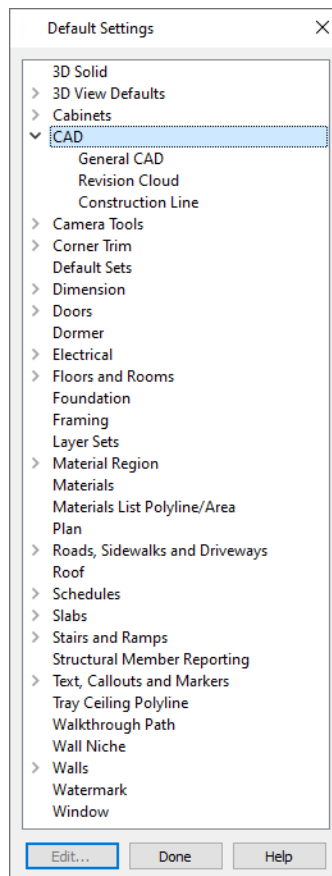

Default settings are an important aspect of template files, which determine the initial settings of new plan and layout files and can be used to save you considerable time. See [Template Files on page 87](#).

You can access a complete list of the various default settings in the current plan or layout file by selecting **Edit> Default Settings**  from the menu.



- Click the arrow beside a category to expand it and access the defaults for items related to that category.
- To open the defaults dialog associated with an item in the list, double-click on the line item, or click on the item and then click the **Edit** button.
- General CAD defaults are view-specific and are only available in views where CAD objects can be drawn. See *CAD Defaults Dialog on page 291*.

Many defaults dialogs can also be opened by double-clicking on a parent and/or child toolbar button of a tool affected by the settings in that dialog. For example, you can:

- Double-click the **Cabinet Tools**  parent button to open the Defaults Settings dialog for Cabinet tools only;
- Double-click the **Base Cabinet**  child button to open the Base Cabinet Defaults dialog.

A few defaults dialogs, such as CAD and Layer Set Defaults, do not have a parent or child tool associated with them. You can add optional buttons to your toolbars to quickly access these dialogs. See *To add a button to a toolbar on page 132*.

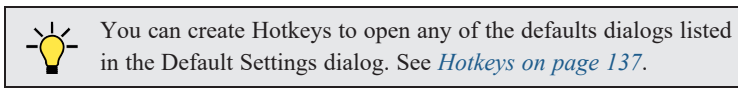

Most items have one defaults dialog that affects all objects of that type. Manual Dimensions and the Text, Callouts, and Markers tools, on the other hand, support multiple Saved Defaults. If you double-click one of these line items, a Saved Defaults dialog will open, allowing you to access and manage all defaults associated with that item. See *Multiple Saved Defaults on page 79*.

Some objects have similar defaults dialogs which can be selected and edited as a group. Multiple Saved Defaults, Camera Defaults, Door Defaults, the Base, Wall, and Full Height Cabinet Defaults, and the Floor Defaults are examples. See *Shift and Ctrl Select on page 214*.

## PREFERENCES

 Preference settings influence the overall environment of the program, such as what the interface looks like, how the tools are accessed, and the basic rules governing how objects are drawn and edited. See *Preferences Dialog on page 95*.

Unlike default settings, Preferences are global, which means that any changes that you make to them will take effect in all plan and layout files.

To access the Preferences dialog, select **Edit> Preferences**  from the menu.

## REGION AND LANGUAGE SETTINGS

There are a few formatting considerations in Chief Architect that are set based on your operating system's Region settings:

- **Units of measurement** - When you first install and launch the program, your template plan and layout files will be set to use either U.S. or metric units, depending on your operating system settings. See *New Plans Panel on page 108*.
- **Currency** - The currency associated with your Region settings will be used in the Materials List, Components dialogs, and Loan Calculator. See *Materials Lists on page 1303* and *Loan Calculator on page 73*.
- **Decimal mark format** - Depending on your operating system settings, either a dot or a comma will be used in dimension lines, dialogs, and anywhere the program can display a numeric value using decimals.
- **Thousands separator** - Depending on your operating system settings, a comma, dot, or non breaking space may be specified as a thousands separator, or digit grouping symbol, for dimension lines.
- **Date format** - The format of date text macros and Sun Angle date labels vary depending on your operating system settings. See *Text Macros on page 540* and *Sun Angles on page 1144*.

## Dynamic Defaults

Dynamic defaults are values that can be changed globally throughout the current plan or layout file. They are available for a variety of objects, including dimension lines, walls, doors, cabinets and rooms.



- If you change a dynamic default value in a defaults dialog, all objects of that type that are set to use the default will update automatically to use the new value.
- Any objects of that type that are not using the default value because of editing will not be affected if you change the default.

Dynamic defaults are presented in several different ways in specification dialogs. Some settings have a **Use Default** radio button, or a “Use Default” option in a drop-down list.

Dynamic default check boxes have a **Default** check box. Uncheck this box to make the setting not dynamic, or check it again to restore the dynamic behavior.

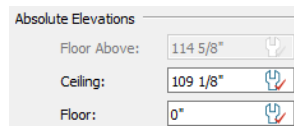
Dynamic default text fields have an Active Defaults  icon in the value field.



- Click on the Active Defaults  icon to remove the red check mark and prevent the value from being dynamic.
- Type a value into the text field. The red check mark is removed from the Active Defaults icon and the setting is no longer dynamic.
- Click on the Defaults  icon to restore the red check mark and make the setting dynamic again.

Materials are another example of an attribute that uses Dynamic Defaults. See [Material Defaults on page 1051](#).

## Set as Default

 The **Set as Default** edit button allows you to apply the settings in a selected object’s specification dialog to the defaults for that type of object.

**Set as Default** affects the attributes of both subsequently created objects as well as any objects using Dynamic Defaults. See [Dynamic Defaults on page 79](#).

Attributes of already existing objects that are not Dynamic Defaults are not affected when **Set as Default** is used, so it should not be viewed as an alternative to setting up defaults before you begin drawing. See [Default Settings on page 77](#).

The **Set as Default** edit tool is not available for Terrain Paths, including Sidewalks, Streams, Terrain Walls and Terrain Curbs. See [Terrain Wall and Curb Tools on page 1254](#).

## Multiple Saved Defaults

 While most objects in Chief Architect have one defaults dialog that controls how all objects of that type are created in a given plan, Manual Dimensions, Revision Clouds, Rich Text, Text, Callouts, Markers, and Arrows can each have Multiple Saved Defaults rather than just one. This lets you set these tools up for more than one requirement or task in

advance, and then simply specify which default you want to use as the Active Default at any given time. See [Default Sets on page 83](#).

Structural Member Reporting and CPU Ray Trace Options also have Multiple Saved Defaults. Rather than affect drawing tools, though, these affect the information in Materials Lists and the properties of ray trace views. See [Structural Member Reporting on page 1306](#) and [CPU Ray Trace Options on page 1171](#).

## USING MULTIPLE SAVED DEFAULTS

There are a couple of different approaches to using Multiple Saved Defaults:

- They can be created for specific tasks. For example, dimension defaults for a site plan can be placed on the “Dimensions, Plot Plan” layer and use a large font size and a format using feet, yards, or meters, while the defaults for cabinet elevations can use the “Dimensions, Kitchen and Bath” layer, a smaller font, and inches or millimeters.
- They can be set up for use at particular scales, such as  $1/4" = 1'$  and  $1/2" = 1'$ , or  $1\text{ mm} = 50\text{ mm}$  and  $1\text{ mm} = 100\text{ mm}$ .
- You can also use a combination of these two strategies.

A selection of Multiple Saved Defaults are included in the template plans installed with Chief Architect to serve as examples of these two approaches. You can use these sets as they are, customize them, or create new ones.

Saved Defaults are all view-specific. This means that if a Saved Default is active in a particular saved view, and you then **Save**  your work and close the view, that Saved Default will be active the next time you open the view - regardless of what is in use in other views. See [Saved Views on page 144](#).

The settings associated with Saved Defaults are static, which means that objects created while one Saved Default is active are not affected when you switch to another Active Default. See [Dynamic Defaults on page 79](#).

Manually-drawn dimension lines are not affected when you switch Active Defaults; however, they do use dynamic defaults inherited from a Saved Dimension Defaults and will be affected if that Saved Dimension Defaults is edited. See [Dimension Defaults Dialog on page 451](#).

 If an object is placed into a new file, either from the library or by copy/pasting, its association with a Saved Dimension Default and/or a Text Style is preserved. See [Copying and Pasting Objects on page 167](#) and [Add to Library on page 332](#).

## TEXT STYLES

In addition to multiple saved defaults, objects that include text within them as well as object labels can be assigned a Text Style, which includes properties like font, color and size. See [Text Styles on page 538](#).

Objects that have text within them are not affected if you assign a new Text Style to their Active Defaults. If a given Text Style is modified, however, any objects that it is assigned to will be affected.

## SAVED DEFAULTS DIALOG

Tools that have Multiple Saved Defaults have a Saved Defaults dialog which lets you:

- Make changes to existing Saved Defaults.
- Add and remove Saved Defaults from the list of those available in the current file.
- Specify which Saved Default is active.



To open the Saved Defaults dialog for any annotation object type, double-click on its name in the Default Settings dialog. See [Default Settings on page 77](#).

If **Edit Active Default on Double-Click** is selected in the Preferences dialog, you can also access the Saved Defaults dialog by double-clicking on the toolbar button for one of these object types. See [General Panel on page 102](#).

 Structural Member Reporting and CPU Ray Trace Options also have Multiple Saved Defaults. See [Structural Member Reporting on page 1306](#) and [CPU Ray Trace Options on page 1171](#).

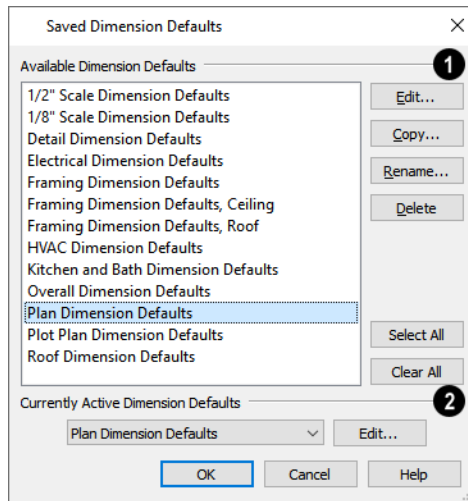

### 1 Available Saved Defaults

A list of the saved defaults for the selected object type displays and can be managed here.

- Click on the name of a Saved Default for the selected object type in the list to select it. Select multiple line items using the Shift or Ctrl key. See [Shift and Ctrl Select on page 214](#).
- Click the **Edit** button to open the defaults dialog for the selected Saved Default.
- Click the **Copy** button to create a new Saved Default. The new Saved Default is a copy of the one selected in the list. Multiple selected Saved Defaults can be copied as well.
- In the New Default Name dialog, which opens when you click Copy, type a short, descriptive, unique name for the new saved default. The Defaults dialog for the new Saved Default opens next. Make any needed changes to its settings and click OK.
- Click the **Rename** button to open the Rename Current Default dialog and type a new name for the current Saved Default. Names are case-sensitive and must be unique.
- Click the **Delete** button to remove the selected Saved Default from the list. Saved Defaults assigned to a Default Set in the current file cannot be deleted, nor can a Saved Dimension Default used by a dimension line. See [Dimension Line Specification Dialog on page 485](#).
- Click the **Select All** button to select all Saved Defaults in the list.
- Click the **Clear All** button to deselect all Saved Defaults in the list.

### 2 Currently Active Saved Defaults

The **Currently Active Saved Defaults** for the selected object type displays and can be changed here.

- Select a Saved Default from the drop-down list to make it active when you click **OK**.
- Click the **Edit** button to open the Defaults dialog for the Saved Default selected in the drop-down list.

Note: if you click Cancel or press Esc in the Saved Defaults dialog after editing, renaming, or copying a Saved Default, your changes will not be retained.

Click **Cancel** to close the dialog without retaining any of your changes. Any newly added Saved Defaults will not be retained.

## Active Defaults Dialog



You can view and modify the defaults that are currently active by selecting **Tools > Active Defaults** to open the Active Defaults dialog.

The name of the currently active view is stated in the dialog's title bar. In an unsaved plan view, the floor level will be stated instead. See [View Windows on page 144](#).

The settings in this dialog are also found on the SELECTED DEFAULTS panel of the specification dialog for most view types in the program, as well as in the Camera Defaults dialogs. See [View Windows on page 144](#) and [Camera Defaults Dialogs on page 1081](#).



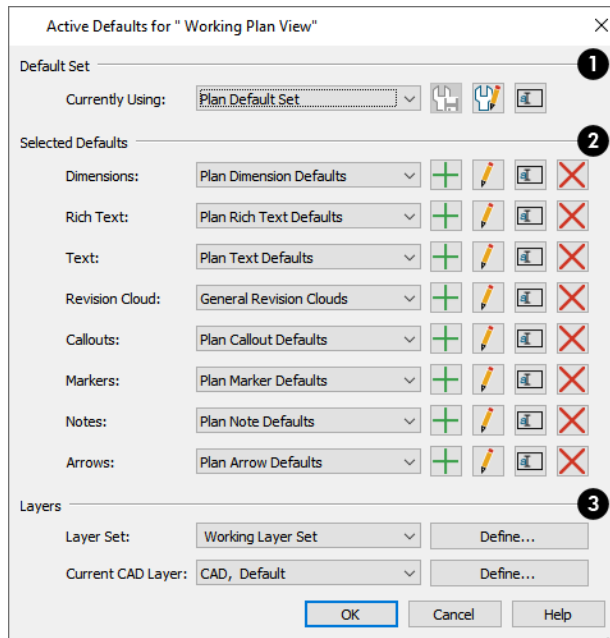

Saved Defaults can also be managed in the Default Sets dialog, and can be grouped into Default Sets for specific drawing tasks. See [Default Sets on page 83](#).



### 1 Default Set





The **Default Set** that you are **Currently Using** is selected in the drop-down list.

- Select a different Default Set from the drop-down list to load its settings below and activate it when you click **OK**.
- When "Active Defaults" is selected instead of the name of a saved Default Set, you can click the **Save New Default Set**  button to create a new Default Set using the Selected Defaults and Layers settings below.
- Click the **Edit Default Set**  button to open the Default Sets dialog. See *Default Sets Dialog on page 84*.
- Click the **Rename Default Set**  button to give the selected set a different name.
- If "Active Defaults" is selected from the **Currently Using** drop-down list, it means that the Selected Defaults, below, are not associated with a saved Default Set.

When "Active Defaults" is selected, you can click the **Save New Default Set** button to create a new Default Set based on the current Active Defaults.

## 2 Selected Defaults

The Selected Defaults for each of the annotation object types display and can be changed here. Note Defaults are not available in layout; however, they are the only defaults available in the Camera Specification dialogs. See *Multiple Saved Defaults on page 79*.

- Select a Saved Default from the drop-down list associated with any of the annotation object types.
- Click the **Add**  button beside any Saved Default to create a new Saved Default for the object type based on the one that is currently selected. Type a short, descriptive name for the new Saved Default, then modify its settings as needed.
- Click the **Edit**  button to open the defaults dialog for the object type and make any changes you may need to the selected Saved Default.
- Click the **Rename**  button to type a new name for the saved default that is currently selected.
- Click the **Delete**  button to remove the selected Saved Default from the list of those available in the plan or layout. Note that if a Saved Default is either in use or assigned to a Default Set, it cannot be deleted.

## 3 Layers

- Select a **Layer Set** from the drop-down list or click the **Define** button to open the Layer Display Options dialog. See *Layer Sets on page 182*.
- Select the **Current CAD Layer** from the drop-down list or click the **Define** button to open the Layer Display Options dialog. Not available for camera views or overviews. See *Current CAD Layer on page 326*.

---

# Default Sets



**Default Sets** are a fast, easy way to switch from one collection of Saved Defaults created for one particular purpose to another collection set up for a different task.

**Default Sets** include defaults for: manually-drawn Dimensions, Text, Revision Clouds, Callouts, Markers, Notes, Arrows, the Current CAD Layer, as well as the Active Layer Set. Multiple Default Sets can be saved in any plan, each for a specific purpose, and you can quickly switch from one set to another as you work. See *Multiple Saved Defaults on page 79*.

Many of the objects included in Default Sets can be assigned a Text Style. See *Text Styles on page 538*.

Saved Defaults are all view-specific; so by extension, Default Sets are as well. This means that if a Default Set is active in a particular saved view, and you then **Save**  your work and close the view, that Set will be active the next time you open the view - regardless of what is in use in other views.

## USING DEFAULT SETS

As with Saved Defaults, there are a couple of approaches to using Default Sets:

- They can be created for specific tasks.
- They can be set up for use at particular scales.
- You can also use a combination of these two strategies.

A selection of Default Sets are included in the template plans installed with Chief Architect to serve as examples of these two approaches. You can use these sets as they are, customize them, or create new Sets.

## ACTIVATING A DEFAULT SET

A Default Set can be selected in any view that supports Dimensions, CAD, and Text: plan view, cross section/elevation views, CAD Details, and Wall Details.

Activating a Default Set really means activating all of the Saved Defaults and layer settings associated with it. There are three ways to activate a Default Set:

- Select a set from the **Active Default Set Control**  **Default Set**  drop-down, which you can add to your toolbars. See *To add a button to a toolbar on page 132*.
- Select a Default Set from the **Currently Using** drop-down list in the Active Defaults dialog. See *Active Defaults Dialog on page 82*.
- Open a saved view in which the Default Set was previously active.

## USING ACTIVE DEFAULTS

If a particular Default Set is active and you switch one of its Saved Defaults to a different Saved Default, the Default Set will no longer be considered active and “Using Active Defaults” will display in the **Active Default Set Control** drop-down. This is not a problem: it simply means that you aren’t using all of the defaults that you may have set up for a specific purpose.

You can view and modify the currently active Saved Defaults in the Active Defaults dialog. You can also save the current defaults as a Default Set for future use, if you wish. See *Active Defaults Dialog on page 82*.



## CREATING DEFAULT SETS

There are two ways to create a new Default Set:

- Click either the **New** button in the Default Sets dialog.
- Click the **Save New Default Set**  button in the Active Defaults dialog.

## DEFAULT SETS DIALOG

 The Default Sets dialog lists the Default Sets available in the current plan file and lets you add, remove, edit, and save them. There are a number of ways to access this dialog:

- Select **Edit**> **Default Settings**  from the menu. Select “Default Sets” and click the **Edit** button. See *Default Settings on page 77*.
- Click the **Default Sets**  button, which you can add to your toolbars. See *To add a button to a toolbar on page 132*.
- Click the **Edit Default Set** button found in the Active Defaults dialog as well as on the SELECTED DEFAULTS panel of various dialogs. See *Active Defaults Dialog on page 82*.

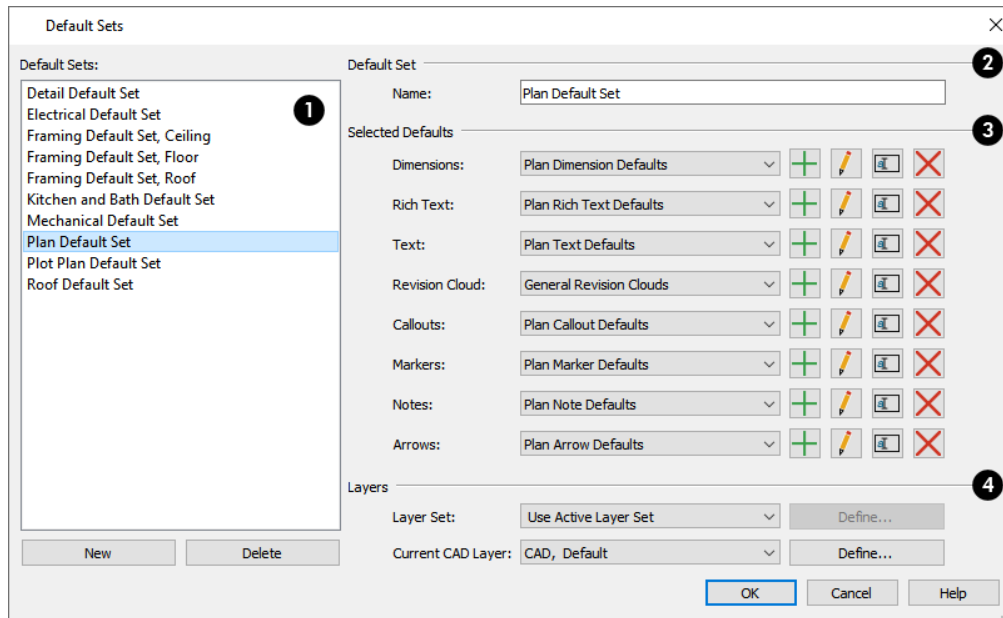

## 1 Default Sets

The Default Sets available in the current plan or layout are listed here.





- Click on an item in the list to select it.
- The selected set is highlighted and its name displays in the **Name** field to the right.
- When a set is selected, its name and other attributes can be edited.
- Click the **New** button below the list to create a copy of the selected Default Set. Type a short, descriptive name for the new set in the New Default Set dialog.
- Click the **Delete** button to delete the selected Default Set from the list and the current file.

## 2 Default Set

- The **Name** of the selected Default Set displays here.
- You can change its name by typing in the text field. Names are case-insensitive and must be unique.

## 3 Selected Defaults

The Saved Defaults for the selected Default Set are listed and can be managed here. See *Multiple Saved Defaults on page 79*.

- Click the **Add**  button to create a new Saved Default for the object type based on the currently selected Saved Default. Type a short, descriptive name for the new Saved Default, then modify its settings as needed.
- Click the **Edit**  button to open the defaults dialog for the object type and make any changes you may need to the selected Saved Default.
- Click the **Rename**  button to assign a different name to the selected Saved Default.
- Click the **Delete**  button to remove the selected saved default from the list of those available in the plan or layout.

#### 4 Layers

- Select a **Layer Set** from the drop-down list or click the **Define** button to open the Layer Display Options dialog. See [Layer Sets on page 182](#).
- Select the **Current CAD Layer** from the drop-down list or click the **Define** button to open the Layer Display Options dialog. Not available for camera views or overviews. See [Current CAD Layer on page 326](#).

---

## Exporting and Importing Default Sets

Default Sets can be exported out of a plan or layout file and then imported into other plans or layouts.

When you export Default Sets, all of the Multiple Saved Defaults in the file are exported, regardless of whether they are used by a Default Set. See [Multiple Saved Defaults on page 79](#).

### EXPORTING DEFAULT SETS

 To export a plan or layout's Default Sets, open that file and then select **File> Export> Export Default Sets**. The Export Default Sets dialog is a typical Save As dialog that lets you specify the exported file's name and its saved location on your computer. See [Exporting Files on page 41](#).

Exported Default Sets files use the **.cadefs** file format. Information exported in **.cadefs** files includes:

- All Default Sets saved in the current file.
- All Saved Defaults for Manual Dimensions, Text, Rich Text, Callouts, Markers, and Arrows.
- All Layer Sets that are associated with a Default Set. Layer Sets not associated with a Default Set are not exported.

### IMPORT DEFAULT SETS DIALOG

 To import Default Sets into a plan or layout, open that file and then select **File> Import> Import Default Sets**. After you select a file to import, the Import Default Sets dialog opens.

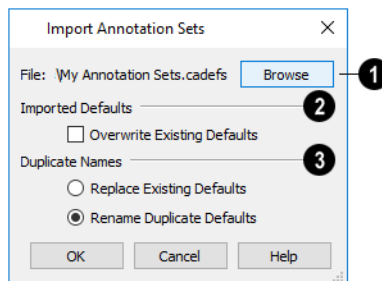

## 1 File

The current file pathname displays here. Click the **Browse** button and browse to the location of a different **.cadefs** file you wish to import. If the pathname is not that of a valid **.cadefs** file, this text will display in red.

## 2 Imported Defaults

Specify how **Imported Defaults** - including Default Sets and Layer Sets - are handled.

- Check **Overwrite Existing Defaults** to delete all Saved Defaults for Text, Rich Text, Callouts, Markers, Arrows, and Dimensions in the file and replace them with imported Saved Defaults. When this is unchecked, which it is by default, existing defaults are retained along with those that are imported. See *Multiple Saved Defaults on page 79*.

Note: Saved Dimension Defaults are not overwritten when Default Sets are imported - even when Overwrite Existing Defaults is checked - if dimensions are present in the active file.

## 3 Duplicate Names

Specify how Saved Defaults with **Duplicate Names** are handled.

- Choose **Replace Existing Defaults** to replace any Saved Defaults already present in the plan.
- Choose **Rename Duplicate Defaults** to retain existing Saved Defaults and rename imported defaults by appending them with a “2”. If subsequent Saved Defaults with duplicate names are imported, the number will increase.

If a specific Layer Set is associated with a Default Set, it will not be imported unless it does not exist in the destination file.

---

# Template Files



When Chief Architect opens a new, blank plan or layout file, the new file is actually a copy of a template using either metric or U.S. units of measurement and predefined default settings, layer settings, wall definitions, page setup information, and more.

Once you are familiar with the default settings in Chief Architect, you can create template files to fit your needs, store them in your Templates directory, and even specify them as the defaults for new files.

If you make changes to a default template file, all subsequently created plans or layouts will use the new default settings.





If a template file is not specified or cannot be found, the program starts new plans using a set of system defined defaults. System defaults are very basic and unlikely to meet your drawing needs, so you should always specify a template plan and layout.

## USING TEMPLATE FILES

A template is used every time you create a new plan or layout file. You can specify which template files are used in the **Preferences**  dialog.

### ***To set a template as your default***





1. Select **Edit> Preferences**  and go to the NEW PLANS panel of the Preferences dialog. See *New Plans Panel on page 108*.
2. Select **U.S. Units** or **Metric Units**.
3. Click the **Browse** button for either the plan or layout template.
4. Select a template file from the Templates directory or navigate to a different location and select a template from there.
5. Make sure that the file you select uses the correct units of measurement. The file names of metric Chief Architect template files are appended "- Metric".

To create a new plan or layout file using a template other than the current preference, choose **File> Templates> New Plan from Template**  or **New Layout from Template** . The program browses to the Templates directory in your Chief Architect Premier X15 Data folder. See *Chief Architect Premier Data on page 37*.



Note: When creating a new plan or layout using a template, be sure to select the appropriate units of measurement. The units used in the new file - U.S. Units or metric - are the same as those in the template used to create it.

### **DATA IN PLAN AND LAYOUT TEMPLATES**

File-specific content and settings in a plan template include:

- Default Settings . See *Default Settings on page 77*.
- Default Sets . See *Default Sets on page 83*.
- Layers, layer sets, and layer settings . See *Layers on page 176*.
- Saved Plan Views. See *Plan Views on page 146*.
- Wall Type Definitions . See *Wall Type Definitions Dialog on page 387*.
- Custom text macros. See *Text Macros on page 540*.
- In plan files only: detail drawings, notes, and schedules in CAD Detail views. See *CAD Details on page 337*.
- If anything is drawn in the template plan, it will be present in all new plans created with that template.

File-specific content and settings in a layout template include:

- Default Settings . See *Layout Preferences and Defaults on page 1334*.
- Layers and layer settings . See *Layers on page 176*.
- Layout Page Information. See *Layout Page Information on page 1358*.
- A title block and border. See *CAD and Text in Layout on page 1337*.
- Drawing Sheet Setup  settings. See *Drawing Sheet Setup Dialog on page 1367*.
- Any text, dimensions, or CAD drawn on any pages of the layout will be present in all new layout files created using that template. Consider adding General notes and other generic text used in multiple projects, however.





## SAVE AS TEMPLATE

 Template files can be created from scratch; however, if you have a plan or layout with settings and data that you would like to use in future projects, you can use the **Save as Default** tool to purge unnecessary data and save a copy in your Templates directory.

### *To create a plan template*

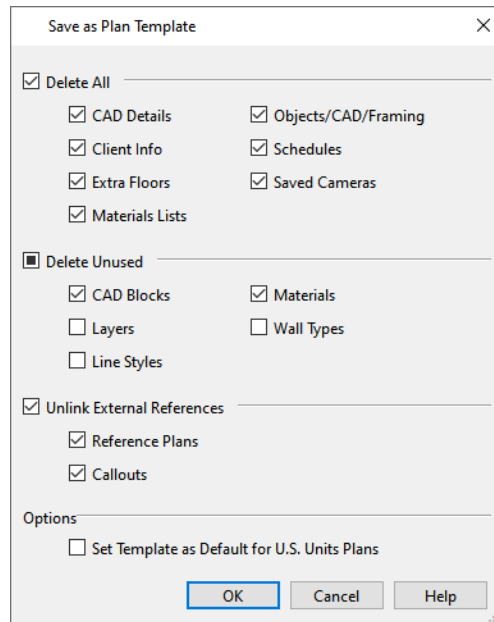
1. Open the plan file with settings and data that you would like to use as a basis for a template.
2. Select **File> Templates> Save As Template** .
3. In the Save as Template dialog for plans:



- Check the box beside each category of object or data that you want to delete from the current file.
- Unless you have a specific reason to retain a particular category, it is best to delete them all.
- Check **Set Template as Default for U.S. Units/Metric Plans** to use the new template as your default template whenever you select **File> New Plan** . Leave this unchecked if you prefer to access this template by selecting **File> New Plan From Template** . See *Units of Measurement on page 38*.

4. In the Save Plan File dialog, give the template file a short, descriptive name and save it in your Templates directory.
5. When you click **Save**, the original plan file remains open, and a new plan with the specified name and save location is created.



The primary difference between plan and layout files is that there are fewer default settings in layouts. In addition, most layout templates include a border and title block whereas plan templates are often blank.

### *To create a layout template*

1. Open the layout file with settings and data that you would like to use as a basis for a template.
2. Select **File> Templates> Save As Template** .

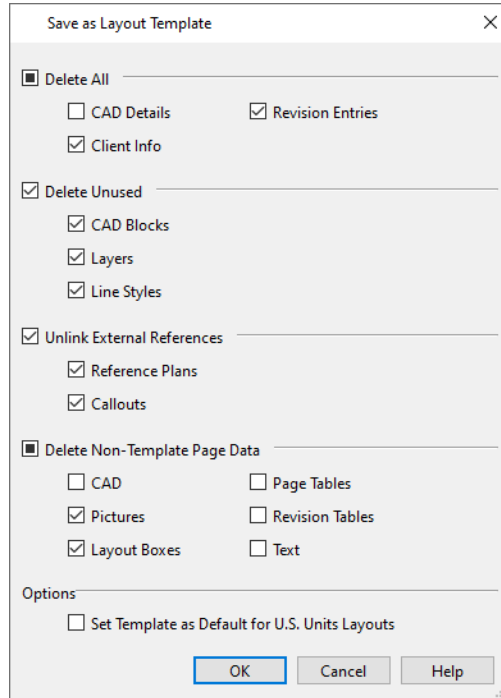

3. In the Save as Template dialog for layouts:



- Check the box beside each category of object or data that you want to delete from the current file.
- Check the box beside each category of **Non-Template Page Data** that you want to remove from non-templates pages. Data on Page Templates is not affected. See [Layout Page Templates on page 1358](#).
- Check **Set Template as Default for U.S. Units/Metric Layouts** to use the new template as your default template whenever you select **File> New Layout** . Leave this unchecked if you prefer to access this template by selecting **File> New Layout From Template** . See [Units of Measurement on page 38](#).

4. In the Save Layout File dialog, give the template file a short, descriptive name and save it in the Templates directory.
5. When you click **Save**, the original layout file remains open, and a new layout with the specified name and save location is created.

## UPDATING TEMPLATE FILES

To change the default settings in your template, you must open the template file as though it were a regular plan or layout by selecting **File> Open Plan**  or **Open Layout** .

After the necessary changes are made, save your work and close the file.

---

## Importing Default Settings

 Default settings are file-specific; however, you can transfer many important default settings from one plan file to another by selecting **File> Import> Import Default Settings**.

Not all defaults settings saved in a plan can be imported from one file to another. For example, Electrical, CAD, Floor, Framing, Foundation, and General Plan Defaults are not imported.

- Defaults associated with Default Sets are not imported but can be exported and imported separately. See *Exporting and Importing Default Sets on page 86*.
- Saved plan views can also be separately imported. See *Importing Saved Plan Views on page 147*.
- Layer Sets can be separately exported and imported, as well. See *Exporting and Importing Layer Sets on page 189*.
- Wall Type Definitions can also be exported and imported. See *Exporting and Importing Wall Types on page 391*.

If the source file that you import from is from an older program version, it may be missing settings available in Version X15. If a default setting is missing, the system default will be imported instead. For this reason, it is best to review defaults before importing them and to avoid importing any defaults that are not actually present in the source file. See *Template Files on page 87*.

Bear in mind that some default settings are dynamic and, if changed, can affect existing objects in the plan. See *Dynamic Defaults on page 79*.

### To import default settings

1. Open the plan that you would like to import default settings into.
2. Select **File> Import> Import Default Settings** .
3. In the Open Plan File dialog, browse to and select the plan file that you would like to import defaults from and click **OK**. See *Importing Files on page 45*.
4. In the Import Default Settings dialog:

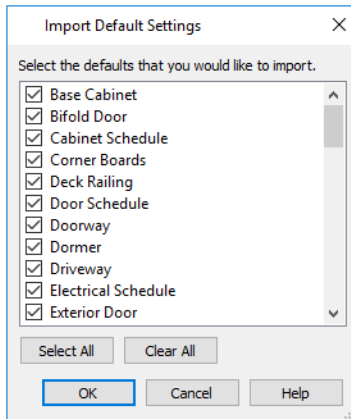

- Use the scrollbar on the right to scroll through the list.
- Check the box beside any defaults that you want to import.
- Click the **Select All** button to place checks in the boxes beside all defaults in the list, or click **Clear All** to clear all of the check boxes.
- Multiple line items can be selected by Shift+ or Ctrl+clicking their names. Then check or uncheck the box beside any selected item to affect the entire selection set. See *Shift and Ctrl Select on page 214*.
- Click **OK** to close the dialog and import the selected defaults.

---

## Reset to Defaults

Select **Edit> Reset to Defaults** to open the Reset to Defaults dialog.

This dialog allows you to reset critical structural settings in the current plan to the default values.

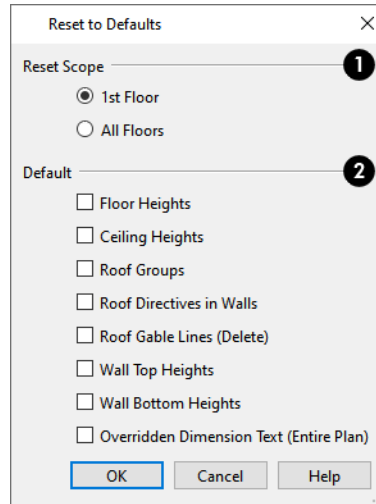

### 1 Reset Scope

The settings can be cleared for the **current floor** or for **All Floors**.

### 2 Default

Specify which settings you want to reset to **Default**.

- Check **Floor** and/or **Ceiling Heights** to reset the default values as specified in the Floor Defaults dialog. Floor and ceiling heights for any room can be changed in the Room Specification dialog. See *Floor Defaults Dialog on page 731*.
- **Roof Groups** - You can specify a room's Roof Group in the Room Specification dialog. This builds the roof over this room and others in the same Roof Group independent of the roof built over other parts of the plan. Check to reset to the default Roof Group, zero. See *Roof Groups on page 795*.
- When **Roof Directives in Walls** are reset, all items on the ROOF panel of the Wall Specification dialog are reset to the default. See *Roof Directives in Walls on page 795*.
- Check **Roof Gable Lines (Delete)** to delete any Roof Gable Lines in the plan. See *Gable/Roof Lines on page 830*.
- **Wall Top Heights** and **Wall Bottom Heights** - Wall shape and height can be edited in 3D views. Check to reset wall shapes and heights. See *Editing Walls on page 368*.
- **Overridden Dimension Text (Entire Plan)** - You can suppress the dimension value associated with a dimension segment and replace it with text of your own. Check this to restore any suppressed dimension values and remove the replacement text. See *Add Additional Text on page 482*.

---

## General Plan Defaults Dialog

 The settings in the General Plan Defaults dialog control basic features of the Chief Architect environment in plan files. Just as with other default settings, they are file specific, which means that they can be set differently in individual plan files. To open this dialog, select **Edit> Default Settings**, select "Plan", and click the **Edit** button.

You can also open this dialog by double-clicking the **Select Objects**  button.

The General Layout Defaults dialog is similar to the General Plan Defaults dialog, but has fewer settings and is available in layout files only. Its settings, too, are file specific.

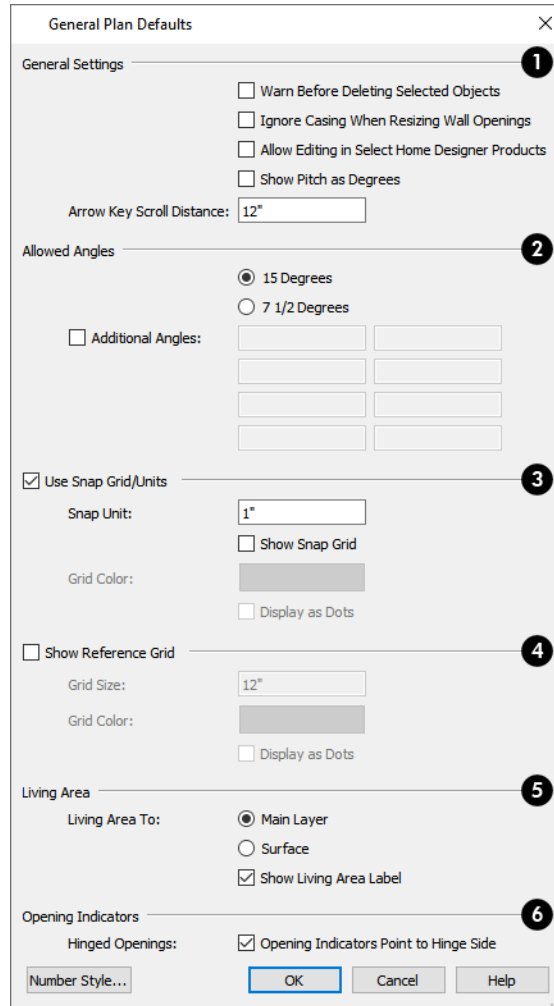

## 1 General Settings

- Check **Warn Before Delete Selected Item** if you want the program to require confirmation before an item is deleted.
- Check **Ignore Casing for Opening Resize** to allow wall openings such as doors to be positioned against an intersecting interior wall. Clear this box retain sufficient space for the opening's specified interior trim width. Not available in layout files.
- Check **Allow Editing in Select Home Designer Products** to allow limited editing of the current file in compatible Home Designer programs. See *Compatibility with Previous Versions on page 35*.
- Check **Warn Before Delete Selected Item** if you want the program to require confirmation before an item is deleted.
- Check **Pitch in Degrees** to display the pitch value in degrees in all dialogs as well as in roof plane labels. Values between -89° and 89° can be entered. When Pitch in Degrees is unchecked, Pitch is described in terms of rise and run: x inches in 12 or x mm in 1000.
- The **Arrow Key Scroll Distance** setting determines how far to scroll in plan view when you press an arrow key. The initial default is 12 inches (300 mm). Not available in layout files. See *Using the Arrow Keys on page 154*.

## 2 Allowed Angles

See [Angle Snaps on page 162](#).

- Select **15 Degrees** to enable Angle Snaps in 15° increments.
- Select **7 1/2 Degrees** to enable Angle Snaps in 7 ½° increments.
- Check **Additional Angles** and enter up to eight custom Allowed Angle values. Click the **Number Style** button to specify the format used to enter angles in dialogs. See [Dialog Number/Angle Style Dialog on page 126](#).

## 3 Snap Grid

See [Grid Snaps on page 163](#).

- Check **Use Snap Grid/Units** to enable Grid Snaps.
- Specify the **Snap Unit** you wish to use. The initial default is 1 inch (10 mm).



It may be helpful to temporarily change the Snap Unit when working with large objects such as terrain or small objects such as molding profiles.

- Uncheck **Show Snap Grid** to turn off the display of the Snap Grid, a visual indicator of the location of the snap points.
- Click the **Color** bar to specify the **Snap Grid Color**. See [Color Chooser/Select Color Dialog on page 203](#).
- Check **Display as Dots** to display the Snap Grid using dots rather than lines.
- You can also click the **Grid Snaps**  toggle button to turn on/off grid snapping.

## 4 Reference Grid

- Check **Show Reference Grid** to display the Reference Grid, the virtual graph paper used to create a sense of scale in plan view.
- Specify the **Reference Grid Size**.
- Click the **Color** bar to specify the **Reference Grid Color**. See [Color Chooser/Select Color Dialog on page 203](#).
- Check **Display as Dots** to display the Reference Grid using dots rather than lines.
- You can also click the **Display Reference Grid**  toggle button to turn on/off the grid display.

## 5 Living Area

Not available in layout files. See [Living Area on page 424](#).

- Select **Main Layer** to have the Living Area calculation measure from the walls' Main Layer.
- Select **Surface** to have the Living Area calculation measure from the walls' exterior surface.
- Uncheck **Show "Living Area"** to turn off the display of the Living Area label.

## 6 Opening Indicators

Not available in layout files. Opening Indicators display on doors, windows, and cabinet doors in camera views when the "Opening Indicators" layer is turned on. See [Opening Indicators on page 549](#).

- Check **Hinge Indicators Point to Handle** for opening indicators to point towards the handle side of openings. When unchecked, opening indicators point towards the hinge side.

## Preferences Dialog

 The settings in the Preferences dialog are global: they apply to all plan and layout files and are preserved between sessions. To access this dialog, select **Edit> Preferences** in Windows® or **Chief Architect> Preferences** in macOS™. Unlike most dialogs in the program, it is not necessary to have a plan or layout file open to access the Preferences dialog.

The Preferences dialog has the following panels:

### APPEARANCE PANEL

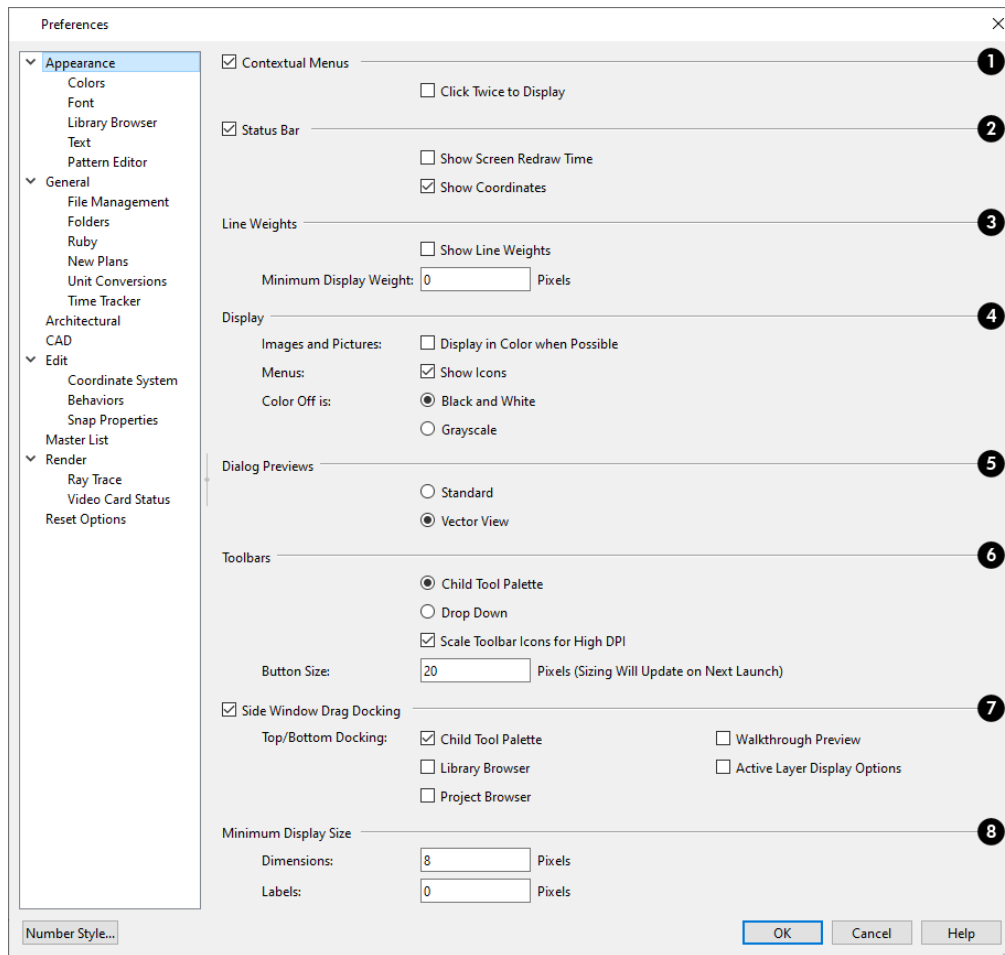

#### 1 Contextual Menus

- Check **Contextual Menus** to activate contextual menus that display when you right-click. See [Contextual Menus on page 19](#).

- Check **Click Twice to Display** to require two right-clicks on an object before the contextual menu displays. This allows the first right-click to be used for object selection. See [Selecting Objects on page 210](#).

Note: In 3D views, the two clicks must be on the same object surface in order for the contextual menu to display: Clicking on two different surfaces of the same object is treated like two single-clicks.

## 2 Status Bar

- Check **Status Bar** to activate the Status Bar at the bottom of the main program window. See [The Status Bar on page 24](#).
- Check **Show Screen Redraw Time** to display the number of seconds it takes to redraw the current view. In camera views, multiple redraw times are reported for individual processes rather than one cumulative time.
- Check **Show Coordinates** to display the coordinates of your cursor at all times on the right side of the Status Bar.
- The coordinates' number style is controlled in the Number Style/Angle Style dialog. See [Dialog Number/Angle Style Dialog on page 126](#).

## 3 Show Line Weights

Specify the on-screen display of **Line Weights**. See [Line Weights on page 1374](#).

- Check **Show Line Weights** to represent line weights on-screen. Depending on your zoom factor and your monitor's resolution, lines may appear to be wider on screen than when they are printed. Zooming closer may reflect a more accurate idea of the actual line width.
- Specify the **Minimum Display Weight**, in Pixels. This is the lowest line weight possible on screen, regardless of how far you zoom out. A Minimum Display Weight of 0 is the same as 1. This setting is ignored when printing or when **Print Preview**  is enabled.

## 4 Display

- **Images and Pictures** - Check **Display in Color when Possible** to display pictures and images in color even when Color  is toggled off. Does not affect the display of images in any 3D views aside from Vector Views. See [Color On/Off on page 191](#).
- **Menus** - Check **Show Icons** to display tool icons next to items in the menus.
- **Color Off is** - Specify whether views appear in **Black and White** or **Grayscale** when color is toggled off. Does not apply to any 3D views aside from Vector Views. See [Vector View on page 1150](#).

## 5 Dialog Previews

Specify whether Dialog Previews use the **Standard** or **Vector View** Rendering Technique by default. See [Dialog Preview Panes on page 22](#).

## 6 Toolbars

Specify how the program's toolbars present child tools when a parent button is clicked.



- Choose **Parent-Child** to display child tools as buttons at the end of the toolbar where the parent button resides.
- Choose **Drop Down** to display child tools when the drop-down arrow to the right of the parent button is clicked.
- Uncheck **Scale Toolbar Icons for High DPI** to prevent toolbar icons from becoming larger on systems running Windows and using Custom Scaling to increase DPI resolution. When checked, toolbar buttons will increase in size when high DPI is used. Not available in the Mac version of the software.
- Specify the desired toolbar **Button Size**, in pixels. Increasing this value will proportionally resize the text in the drop-down toolbars, as well. See *Toolbar Button Size on page 131*.

## 7 Side Window Drag Docking

Specify whether side windows dock to the edges of the program window. See *View and Side Windows on page 17*.

- Uncheck **Side Window Drag Docking** to prevent undocked side windows from docking when moved using the mouse. A side window can still be docked to its last docked location by double-clicking its title bar.
- **Top/Bottom Docking** - Check the box beside a side window's name to allow it to dock on the top and bottom edges of the program window. Does not affect docking to the left and right sides.

## 8 Minimum Display Size

Specify the minimum display size of **Dimensions** and **Labels**, in pixels. This is the on-screen size and does not affect printed or exported output. To use the printed scale, set these values to 0 or turn on **Print Preview** .

- Dimension sizes are set in the Dimension Defaults dialog. See *Dimension Defaults Dialog on page 451*.
- Printed label sizes are set in the Schedule Defaults dialogs. See *Labels Panel on page 697*.

## COLORS PANEL

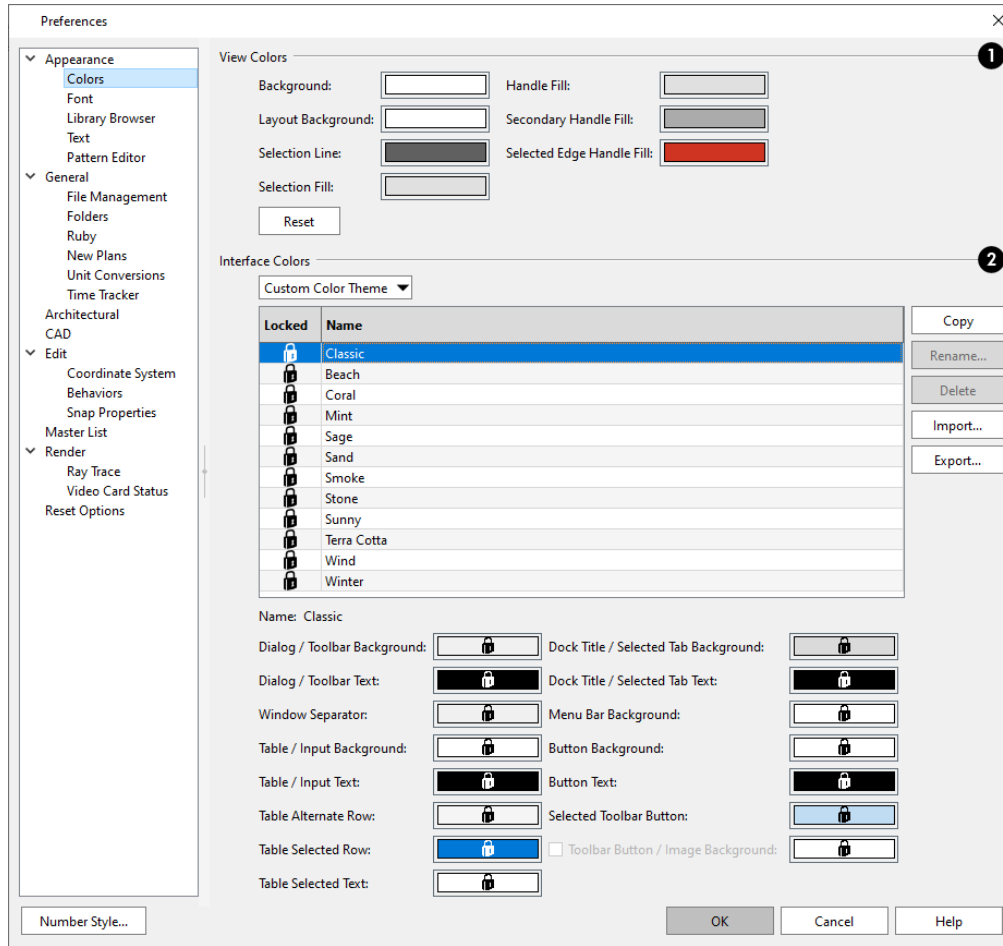

### 1 View Colors

Specify view background colors and colors associated with selected objects by clicking a color bar to open the Select Color dialog. See [Color Chooser/Select Color Dialog on page 203](#).

- Specify the **Background** color for plan view and CAD Details. The background colors for 3D views can be set in their defaults and specification dialogs. See [Backdrop Panel on page 1122](#).
- Specify the **Layout Background** color, which is the background color in layout files. See [Layout on page 1333](#).
- Specify the **Selection Line** color, which is the color of the lines that represent object(s) and their edit handles when they are selected. The opacity of this color can also be specified.
- Specify the **Selection Fill**, which is the fill color for selected objects and its level of opacity. Note that depending on the fill assigned to a selected object, its Selection Fill color may vary.
- Specify the **Secondary Handle Fill**, which is used to identify special edit handles such as the Key Frame handles on Walkthrough Paths. Both color and opacity level can be set. See [Key Frames on page 1208](#).
- Specify the **Selected Edge Handle Fill**, which is the fill color of the edit handle on a selected object's Selected Edge and its level of opacity. See [Selected Edge on page 212](#).
- Click the **Reset** button to reset all View Colors to the installed defaults.

Note: If the Selection Line and Handle Fill Colors are similar, it may be difficult to distinguish between active and inactive CAD Points.

## 2 Interface Colors

Specify the colors for a variety of different elements in the software’s interface by selecting an option from the drop-down list:

- Select “System” to use your operating system’s color settings.
- In the Mac version of the software, select “Force Light” to use Light Mode in Chief Architect regardless of the system settings, or “Force Dark” to use Dark Mode in Chief Architect regardless of the system settings.
- Select “Custom Color Theme” to apply a color theme to the program interface and select its characteristics below.

The table and settings that follow are only available when “Custom Color Theme” is selected, above:

- The table lists all available Color Themes. Click on a line item to select and activate that color theme.
- Locked themes are installed with the program and cannot be modified or deleted.
- To create an unlocked theme, select any theme in the list and click the **Copy** button.
- Select an unlocked theme and click the **Rename** button to specify a new name.
- Select an unlocked theme and click the **Delete** button to remove the theme from the list.
- When an unlocked theme is selected, the settings below the table are enabled, allowing you to specify the colors for a variety of elements in the program interface.
- When **Toolbar Button/Image Backgrounds** is unchecked, toolbar buttons and images in dialogs use the Dialog/Toolbar Background color.

The program interface will update as you select different color themes or edit the selected unlocked theme’s color settings.

## FONT PANEL

The FONT panel controls the font used by dimensions in legacy plans when they are opened in Chief Architect Premier X15, as well as the font used in the Materials List.

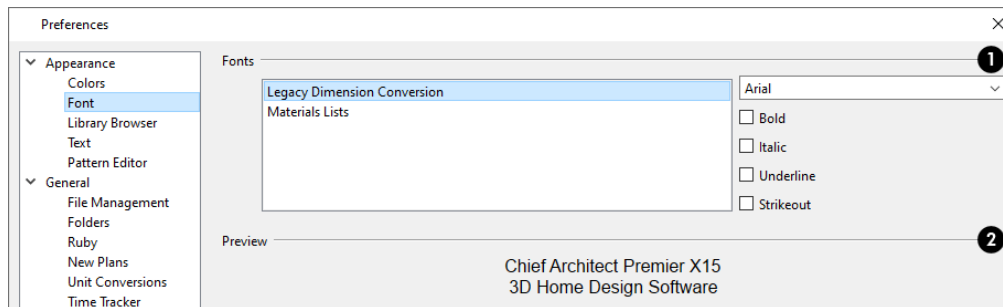

## 1 Fonts

Specify the Fonts for use in Legacy Dimension Conversion and Materials Lists.

- Select **Legacy Dimension Conversion** from the list to specify the font used by dimensions in legacy files from Versions 10 to X3. See *Dimensions on page 448*.

- Select **Materials Lists** from the list to specify the font used by Materials Lists and the Master List. See *Materials Lists on page 1303*.

 Legacy Dimension Conversion settings only affect plans from previous versions when they are opened in Chief Architect Premier X15. Set these values to the default font that you used in previous versions before opening legacy files.

- Select a **Font** from the drop-down list for the use selected to the left. See *Fonts and Alphabets on page 495*.
- Select one or more font styles to apply to the selected use: **Bold**, **Italic**, **Underline**, and/or **Strikeout**.

## 2 Preview

A sample of the selected font and style displays here.

For information about text in Chief Architect Premier X15 files, see *Text, Callouts, and Markers on page 493*.

## LIBRARY BROWSER PANEL

The LIBRARY BROWSER panel controls the appearance of the Library Browser window. See *The Library Browser on page 946*.

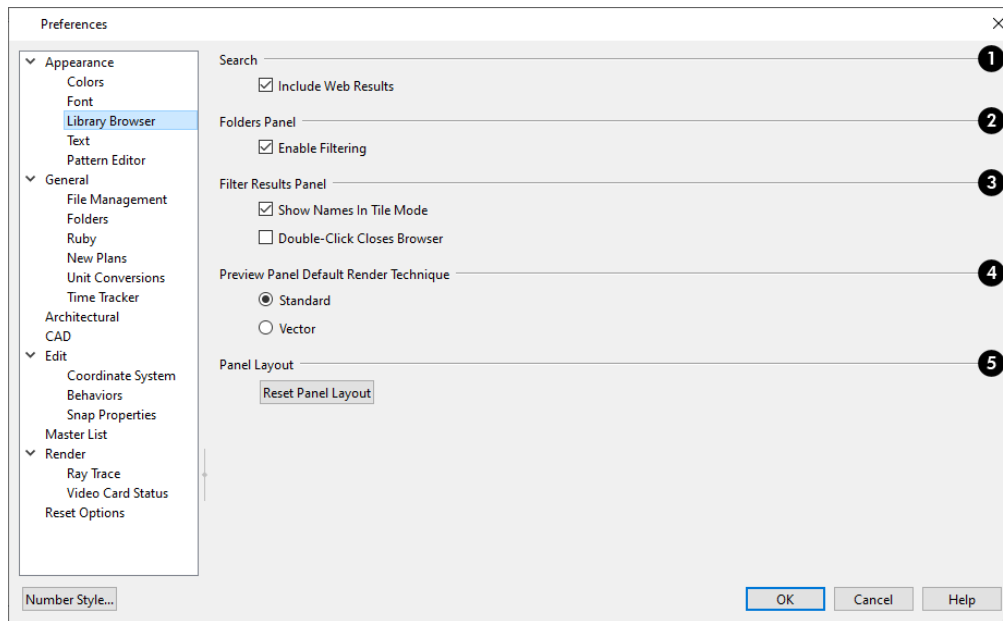

### 1 Search

When **Include Web Results** is checked, content that is available for download will be included in the Filter Results. Uncheck this to only include content already present in the library in the Filter Results. **Include Web Results**  is also a toggle button in the Library Browser. See *The Library Browser on page 946*.

### 2 Folders Panel

When **Enable Filtering** is checked, the tree list in the Folders panel will be filtered according to the active search parameters. Uncheck this to show all content in the tree list, regardless of the active filter.

### 3 Filter Results Panel

- When **Show Names in Tile Mode** is checked, the names of items in the Filter Results panel list are reported under each thumbnail when Tile Mode is in use. When unchecked, only the thumbnails display.
- Check **Double-Click Closes Browser** to close the Library Browser side window when you double-click on an item in the Filter Results list. Doing this will also close any other side windows that the Library Browser is docked with.

### 4 Preview Panel Default Render Technique

Specify whether selected library items are displayed in the Preview panel using the **Standard** or **Vector View** Rendering Technique. See *Rendering Techniques on page 1150*.

To restore the original size and position of the Library Browser and other side windows, click the **Restore Side Windows** button on the *Reset Options Panel on page 125*.

## TEXT PANEL

The settings on the TEXT panel control some behaviors affecting text objects. See *Text, Callouts, and Markers on page 493*.

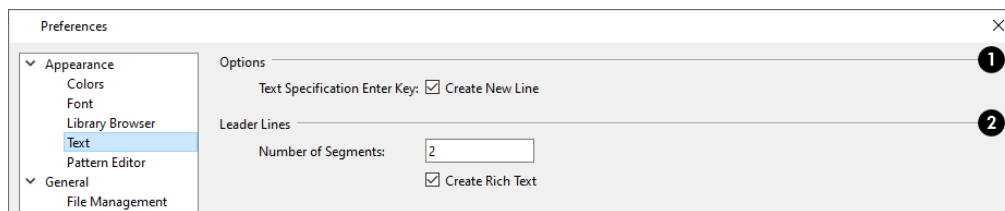



### 1 Text Specification Enter Key

- Uncheck **Create New Line** to close the Text and Rich Text Specification dialogs when the Enter key is pressed. When this is checked, a new line of text is created when Enter is pressed and the dialog remains open.

### 2 Leader Lines

Specify how the **Leader Lines**  tool functions. See *The Text Tools on page 497*.

- Specify the **Number of Segments** that text Leader Lines have. Changes to this setting affect subsequently drawn Leader Lines: existing lines are not affected.
- Uncheck **Create Rich Text** to create **Text**  objects when the Leader Line tool is used. When checked, **Rich Text**  is created.

## PATTERN EDITOR PANEL

The settings on the PATTERN EDITOR panel control the appearance of elements in Pattern windows. See *Editing Custom Patterns on page 197*.

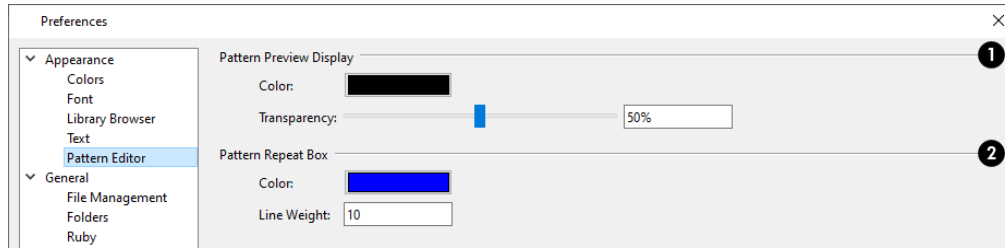

## 1 Pattern Preview Display

- Specify the **Color** of the Pattern Preview. See *Color Chooser/Select Color Dialog on page 203*.
- Specify the **Transparency** of the Pattern Preview lines. A value of 100% produces a preview that is invisible.

## 2 Pattern Repeat Box

- Specify the **Color** of the Pattern Repeat Box.
- Specify the **Line Weight**, or thickness, of the Repeat Box in scaled pixels.

## GENERAL PANEL

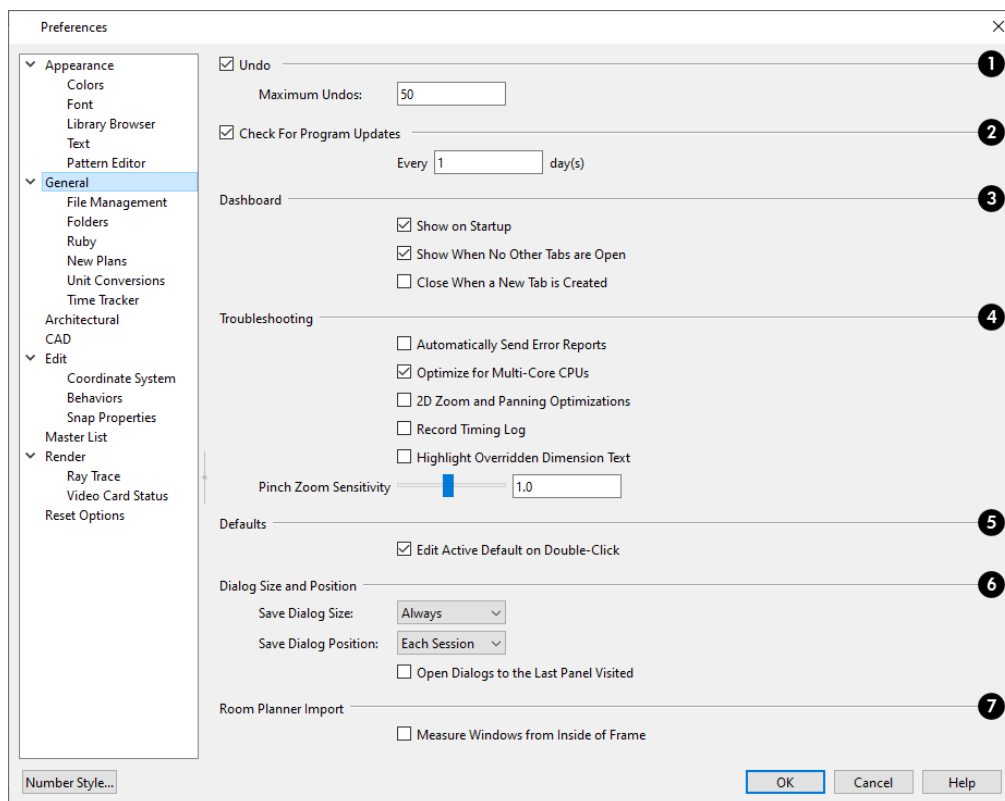

## 1 Undo

- When Undo is checked, the Undo and Redo commands can be used. See [Undo and Redo on page 289](#).
- **Maximum Undos** - Specify how many levels of Undo and Redo you want available, from 1 to 100. Undo files are saved in the Undo Directory.

## 2 Check For Program Updates

- When **Check For Program Updates** is checked, Chief Architect will check for updates when the program is launched.
- By default, Chief Architect checks for program updates once a day when the program is launched. You can specify a different frequency, in days, if you prefer.

## 3 Dashboard

- When **Show on Startup** is checked, the Dashboard window opens when Chief Architect is launched. See [Dashboard on page 11](#).
- When **Show When No Other Tabs are Open** is checked, the Dashboard will open when all other view tabs are closed. See [View Windows on page 144](#).
- Check **Close When a New Tab is Created** to close the Dashboard tab whenever a new view is opened. When this is unchecked, the Dashboard remains open when a new tab is created.

## 4 Troubleshooting

- Check **Automatically Send Error Reports** to automatically send a report to Chief Architect in the event of a program error. This box becomes checked automatically if you click the Send Report button in an error message box. If an unsent error report generated during the current program session exists, it will be sent automatically if this box is checked by the user. See [Error Messages on page 1406](#).
- Uncheck **Optimize for Multi-Core CPUs** to turn off program optimizations for multi-core processors. This box is checked by default and should only be unchecked for technical troubleshooting purposes.
- Uncheck **2D Zoom and Panning Optimizations** to turn off program speed optimizations for zooming and panning in 2D views.
- Check **Record Timing Log** to have the program create an event timing log in the Hidden User Settings Folder for troubleshooting purposes. Unless you are actively troubleshooting program performance, this box should be unchecked.
- Check **Highlight Overridden Dimension Text** to highlight the text in any dimension labels where the actual dimension label has been suppressed. See [Add Additional Text on page 482](#).
- Specify the desired **Pinch Zoom Sensitivity**, which affects the zoom rate for touch screens, trackpads, as well as Ctrl+scroll wheel actions in Chief Architect. The default value is 1. See [Using Input Devices on page 14](#).

Additional options are available in the Mac version of the software only:

- When **Mouse Movement Optimizations** is checked, zooming using the mouse scroll wheel is optimized for Mac systems. This box is checked by default and should only be unchecked when troubleshooting issues with the mouse scroll wheel in the Mac version of the software.

- Use the **Mouse Scroll Sensitivity** scrollbar or text field to control how sensitive the mouse scroll wheel is when zooming using the mouse scroll wheel in the Mac version of the software.

## 5 Defaults

- Uncheck **Edit Active Default on Double-Click** to open the Saved Defaults dialog when you double-click the toolbar button associated with a drawing tool that has multiple saved defaults. When this box is checked, the defaults dialog for the currently active saved default opens. See *Multiple Saved Defaults on page 79*.

## 6 Save Dialog Size and Position

- Specify when to **Save Dialog Size** and **Save Dialog Position: Always, Per Session, or Never**. See *Dialog Size and Position on page 21*.
- Check **Open Dialogs to the Last Panel Visited** to open paneled dialogs to the last panel that you accessed during the current program session. When unchecked, dialogs always open to the first panel. See *Dialogs on page 19*.

## 7 Room Planner Import

Specify how window sizes in **Room Planner Imports** are measured. See *Import Room Planner File on page 1226*.

- Check **Measure Windows from Inside of Frame** to measure window heights and widths from the inside of the frame. When unchecked, window sizes are measured from the outside of the window frame, as they are in the Window Specification dialog in Chief Architect. See *General Panel on page 592*.

## FILE MANAGEMENT PANEL

The settings on the FILE MANAGEMENT panel let you modify functions related to the program's plan and layout file management.



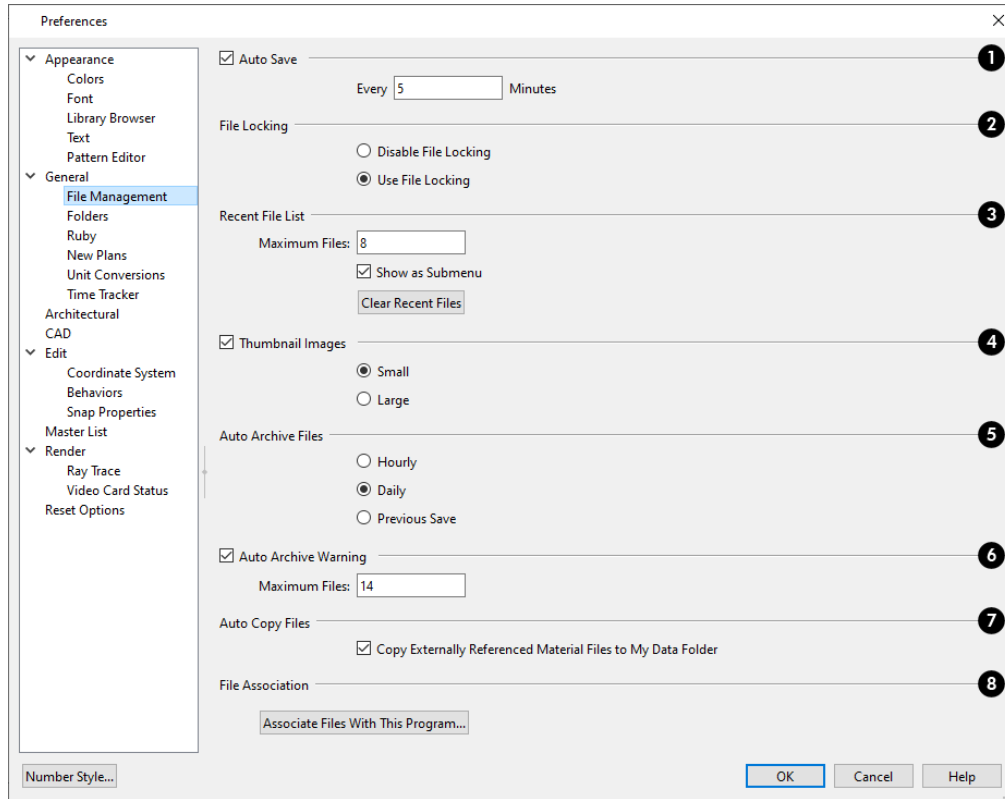

## 1 Auto Save

- Check **Auto Save**, then enter a value greater than zero in the text field to specify the frequency in minutes that Auto Save files are created. Auto Save files are stored in the Archive folder. See [Auto Save Files on page 44](#).

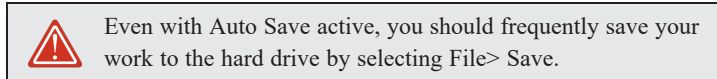

## 2 File Locking

Choose whether or not to lock **.plan** and **.layout** files when they are open. File Locking prevents another program or copy of Chief Architect software from opening and modifying the same file at the same time and is recommended in nearly all circumstances.

- Select **Use File Locking** to lock files.
- Select **Disable File Locking** to disable this feature.

## 3 Recent File List

Specify the maximum size and location of the Recent File List.

- Specify the maximum number of recently opened **files** to list in the Dashboard window and at **File> Open Recent Files**. You can open any of the files in this list by selecting it, making it a quick way to access your most recent work.
- Uncheck **Show in Submenu** to display the Recent File List at the bottom of the File menu rather than in a submenu.

#### 4 Thumbnail Images

Thumbnail images are file previews that display when opening or searching for saved plan and layout files. [Thumbnail Images on page 36](#).

- Check **Thumbnail Images** to automatically create thumbnail images when a plan or layout is first saved. If this option is disabled, you can still create thumbnails manually.
- Select either **Small** or **Large thumbnails**. Large thumbnails provide a higher quality image but result in larger file sizes.

#### 5 Auto Archive Files

Select an **Auto Archive Files** option. Every time a file is saved, the current archive file is overwritten. See [Auto Archive on page 42](#).

- Select **Hourly** to save and append archive files based on an hourly format.
- Select **Daily** to save and append archive files based on a daily format.
- Select **Previous Save** to archive only the most recently saved file, unappended.

#### 6 Auto Archive Warning

- Uncheck **Auto Archive Warning** to prevent the program from prompting you to manage archive files. When checked, you will be reminded to manage the current file's archives when they reach the number specified below.
- Enter the **Maximum Files**, which is the number of files that must be in a file's Archive directory before the Manage Archives warning will display. See [Manage Archives on page 43](#).

#### 7 Auto Copy Files

- When **Copy Externally Referenced Material Files to My Data Folder** is checked, the program automatically makes a copy of the material texture and map files associated with any custom materials that you create in your Chief Architect Premier X15 Data folder. This can help prevent these files from becoming lost if the originals are deleted. See [About Materials on page 1050](#) and [Chief Architect Premier Data on page 37](#).

#### 8 File Association

- Click the **Associate Files With This Program** button to direct your computer's operating system to associate all **.plan**, **.layout**, **.calib**, and **.calibz** files with Chief Architect Premier X15. This button will not be active if plan, layout, and library files are already associated with this program and version. See [File Association on page 35](#).

### FOLDERS PANEL

Chief Architect stores many support files in various folders on your computer. The default locations of these directories are listed and can be redefined on the FOLDERS panel if necessary.

You do not need to change default locations under normal circumstances, but sometimes it may be preferable to locate certain files in another location. To specify a new default folder for a particular purpose, click the **Browse** button to the right of that item.



Changing settings on the Folders panel can result in unexpected program functionality.

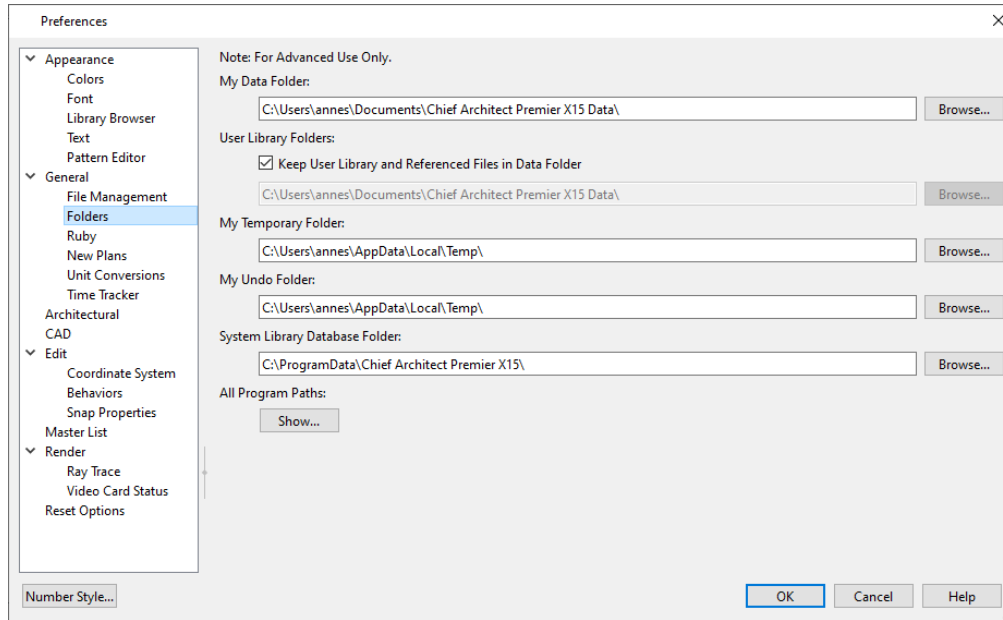

- Important user-specific information is stored in the **Chief Architect Premier X15 Data** folder, which is located in your Documents directory by default. See [Chief Architect Premier Data on page 37](#). If you specify a new location, any custom toolbars or other settings that you may have will not be copied to the new location: you can do this yourself if you wish.

 Make sure that the location you specify is accessible and has adequate space for the files in this folder. See [Data Folder Name and Location on page 37](#).

- The **User Library Folder** contains custom library objects saved in the User Catalog in the Library Browser. When **Keep User Library and Referenced Files in Data Folder** is checked, this folder's location will update if you specify a new location for the Data folder, above. When this is unchecked, this folder will remain in the location specified below. If you specify a new location, you will be presented with the option of automatically copying your existing User Library content as well as your Backdrops, Images, Patterns, and Textures folders to the new location. See [The User Catalog on page 961](#).
- By default, **Temporary** files and **Undo** files are stored in the same folder. If you wish to use a different folder, you must specify a directory on a hard drive with sufficient space to hold these files. See [Undo and Redo on page 289](#).
- Chief Architect will not let you save your work in the Temporary or Undo folder, or open files saved in either location.
- All library content aside from your User Catalog is stored in the **System Library Database Folder**. By default, this folder is created in the directory intended for shared application data in your operating system (C:\ProgramData in Windows;/Library/Application Support in macOS). If you specify a new location, the program will automatically copy your library content to that location. See [Library Content on page 961](#).

 If you choose to use a different folder, you must specify a directory on a hard drive with sufficient space to hold these files.

- **All Program Paths** - Click the **Show** button to open the Program Paths dialog, where you can find the location of files that may be needed for troubleshooting purposes. See [Program Paths Dialog on page 1407](#).

## RUBY PANEL

The settings on the RUBY panel let you specify the Ruby safe level and the location of any Ruby files you may run in the Ruby Console. See *The Ruby Console on page 1399*.

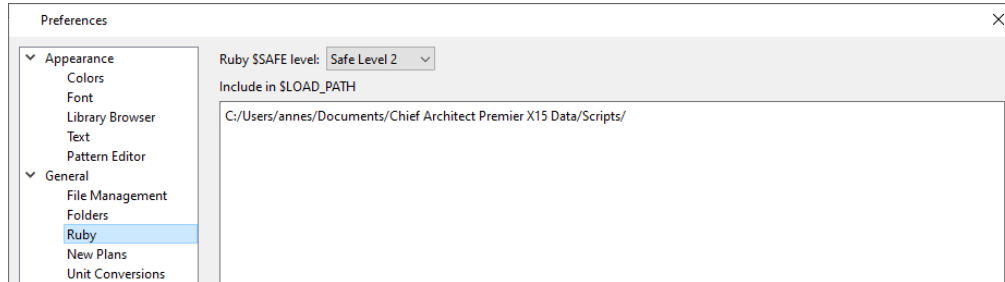

- Select the **Ruby \$SAFE level** you wish to use from the drop-down list. A level of 0 is unprotected and could allow a malicious script to be run, while a level of 5 may prevent you from using the Ruby Console productively. Level 2 is chosen by default.
- In the **Include in \$LOAD\_PATH** field, specify the pathname of the directory where your Ruby scripts are stored. Separate multiple locations with a semi-colon.

## NEW PLANS PANEL

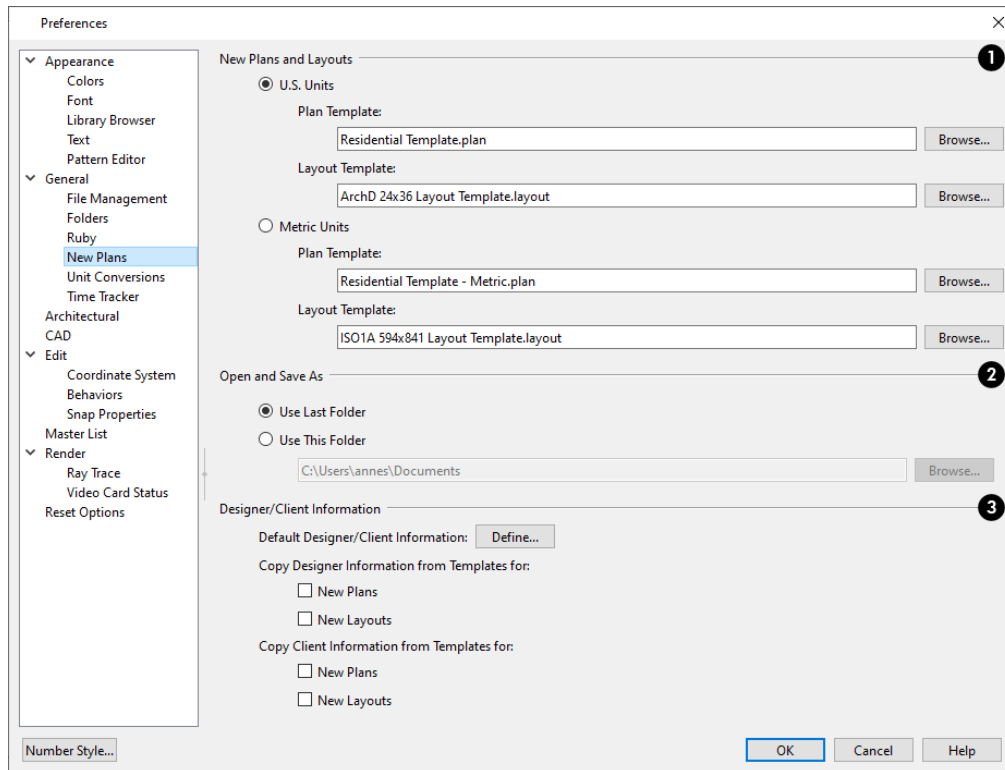

### 1 New Plans and Layouts

Specify what system of measurement new plans and layout files use, as well as what files are used as the templates for new files. See *Template Files on page 87*.

- Select the **U.S. Units** or **Metric Units** radio button to determine the units used in your new files. Once a new plan or layout is created, its measurement system cannot be changed.



Be sure that you use U.S. Unit files for your U.S. Unit templates and metric files for your metric templates. When a new file is created, it uses units of the template file regardless of your Preference setting.

- **Plan Template** - Displays the template file the program uses when you open a new plan. Click the **Browse** button to select a new plan template.
- **Layout Template** - Displays the template file the program uses when you open a new layout file. Click the **Browse** button to select a new layout template.

## 2 Open and Save As

Control how the program behaves when a new plan is opened or an existing plan is saved.

- **Use Last Folder** refers the program to the directory last used to save or open a plan file.
- **Use This Folder** refers the program to a particular location specified by you.
- Click the **Browse** button to define a particular directory when **Use This Directory** is selected.

## 3 Designer/Client Information

Specify where initial Designer/Client Information is drawn from in plan and layout files. See [Designer/Client Information on page 541](#).

- **Default Designer/Client Information** - Click the **Define** button to enter the global default designer and client information that applies to all Chief Architect plan and layout files.

Instead of using the global defaults, you can specify that the information in **New Plans** and **New Layouts** be drawn from the template files used to create them. See [Template Files on page 87](#).

- The **Copy Designer Information from Templates for** options let you specify whether Designer Information is drawn from templates or the global defaults.
- The **Copy Client Information from Templates for** options let you specify whether Client Information is drawn from templates or the global defaults.

## UNIT CONVERSIONS PANEL

In many places throughout Chief Architect, you can specify the size of an object with any Length unit listed on the UNIT CONVERSIONS panel. Using the data on this panel, the program will convert your entry into the unit set in the Dialog Number/Angle Style dialog. See [Dialog Number/Angle Style Dialog on page 126](#).

These conversions are also useful when you import drawings. When an object is drawn in a Chief Architect plan file, it is always at its true, unscaled size and the drawing is only scaled when you print it. This means that if you import a scaled drawing, you must compensate for its scaling by creating a custom unit of measurement. See [Import Drawing Assistant on page 1228](#).

You can also create units that measure area and volume, which can be used in custom Materials List formulas and Ruby macros. See [Materials List Formulas on page 1320](#) and [Ruby in Chief Architect on page 1386](#).

The default unit conversions are locked and cannot be changed, but custom conversions can be added to the list and later modified.

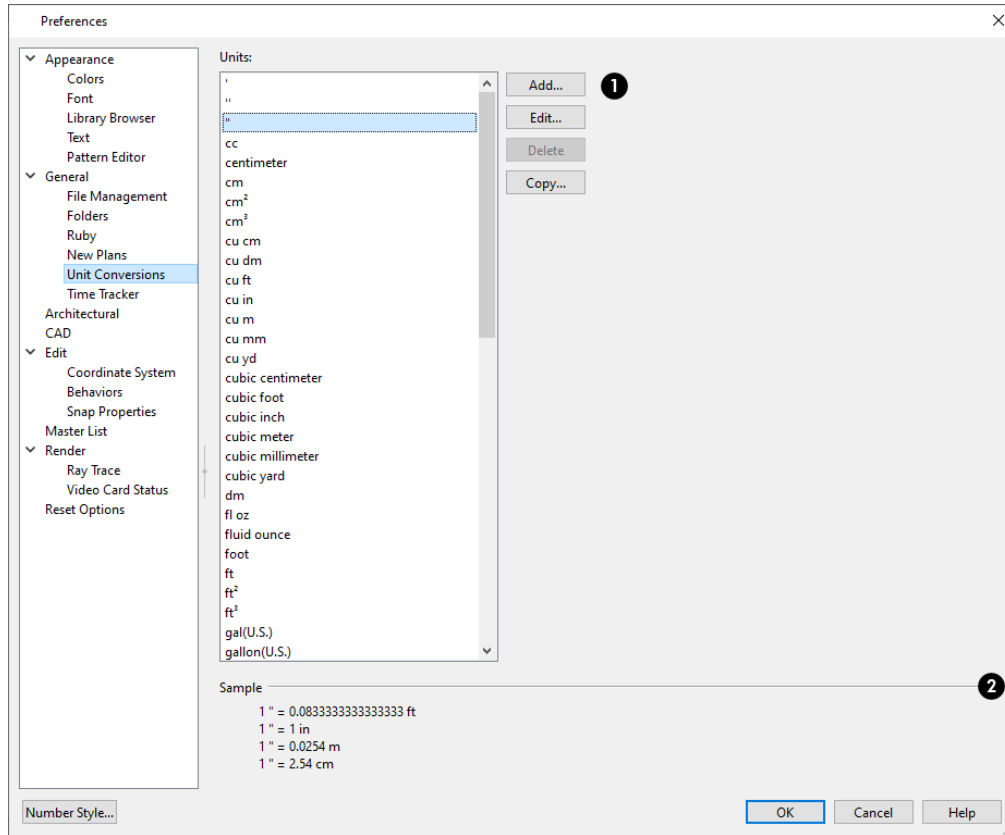

### 1 Units

A list of available units of measurement displays here. Click on the name of a unit to select it.

- **Add, Edit, Delete,** or **Copy** the unit conversions. Certain unit conversions are locked and cannot be edited or deleted.
- If you click **Add, Edit** or **Copy**, the Add Unit Conversion dialog displays.

### 2 Sample

An example of how the unit selected above converts to a selection of similar units. You can use this to verify that any unit conversion you create is correct.

## ADD UNIT CONVERSION DIALOG

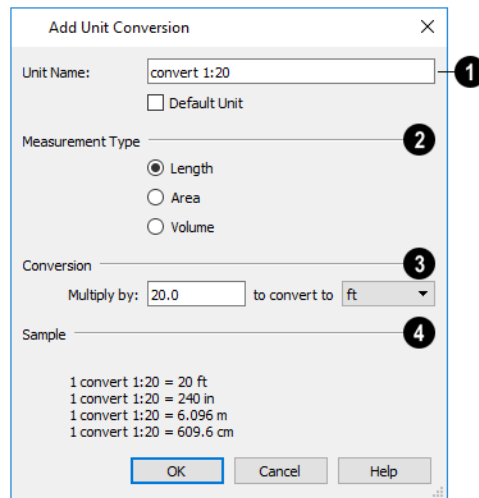

### 1 Unit Name

- Type a short, descriptive name of the new unit. Names must be unique: the names of units installed with the program cannot be used.
- Names can include any characters, as well as spaces. Bear in mind, though, that names of units for measuring length that have numbers in them may be unusable if entered in some dialogs in the program.
- Check **Default Unit** to display this new unit in places that present lists of available units. For example, if you have inches as units and make inches a default, inches appear on the list when you are given a choice of units, such as in the Import Drawing Assistant. In other places, such as the Materials List, all units are listed.

### 2 Measurement Type

Specify what the new unit measures.

- Select the appropriate radio button: **Length**, **Area**, or **Volume**.

### 3 Conversion

- Specify how much to **Multiply by** your custom unit **to convert to** the unit you select from the drop-down list. A measurement type must be selected before the list is populated.

### 4 Sample

An example of the Unit Conversion defined above displays here.

When importing a drawing with a 1" = 20' scale, for example, create a unit to convert this scaling to 1" = 1".

#### *To create a new unit of measurement*

1. Click the **Add** button to open the Add Unit Conversion dialog.
2. Type a short, descriptive name like "convert 1:20" in the **Unit Name** field.
  - Because this unit will be used only for scaling conversion, including numbers in its name will not cause any issues.
3. Select **Length** as the **Measurement Type**.

4. Type 20 in the **Multiply by** field.
5. Select “ft” from the drop-down list.

Note: You can achieve the same results if you Multiply by 240 to convert to inches.

6. Click **OK** to close the dialog.

## TIME TRACKER PANEL

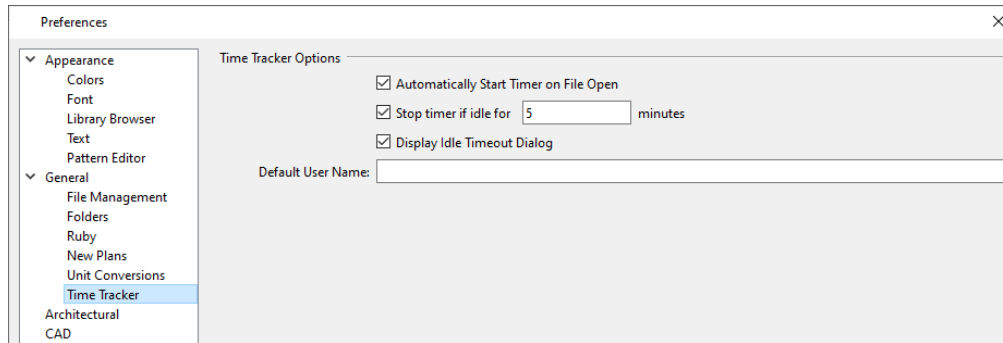

- Uncheck **Automatically Start Timer on File Open** if you do not want to begin logging time whenever a file is opened. If this is not checked, you must select **Tools> Time Tracker> Start Time Logging**  to begin logging.
- Check **Stop timer if idle for \_\_ minutes**, and enter the number of minutes to stop logging time when a plan has been idle.
- Check **Display Idle Timeout Dialog** to warn when a plan is considered idle.
- Specify the **Default User Name** used in Time Log entries. This field is initially populated by the name that you entered when you registered your software license. See *Designer/Client Information on page 541*.

For more information, see *Time Tracker on page 60*.



## ARCHITECTURAL PANEL

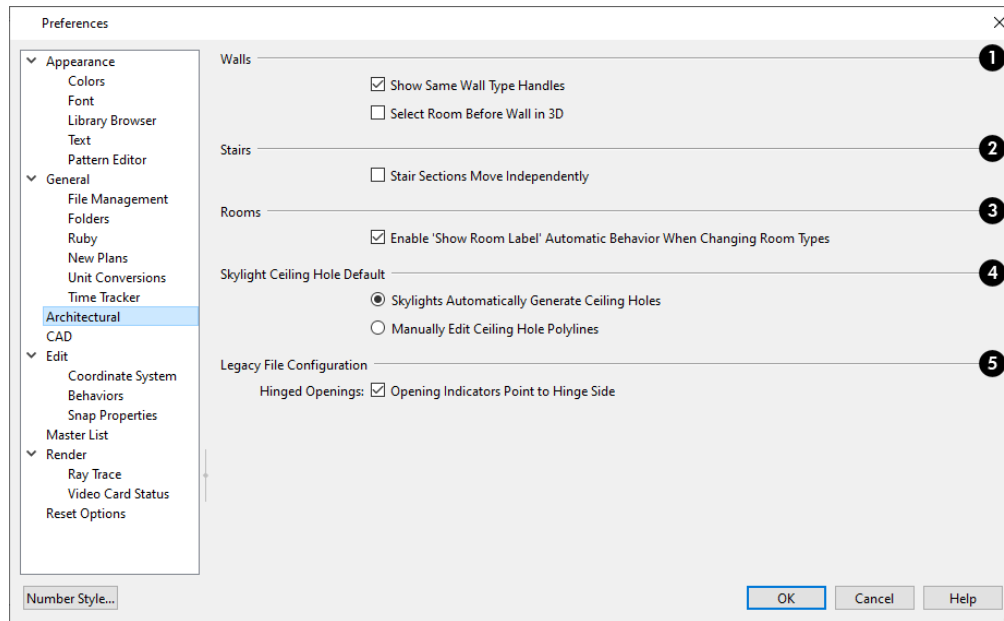

### 1 Walls

Select the desired default behaviors for selected walls.

- Check **Show Same Wall Type Handles** to display edit handles on selected walls that draw new walls of the same type when dragged. See [Same Wall Type Edit Handles on page 373](#).
- Check **Select Room Before Wall in 3D** to select the room defined by a wall when you click on the wall in 3D views. See [Selecting Rooms on page 418](#).

### 2 Stairs

- Check **Stair Sections Move Independently** to allow stair sections connected by landings to move separately, without moving the entire staircase. See [Editing Stairs and Ramps on page 750](#).

### 3 Rooms

- Uncheck **Enable 'Show Room Label' Automatic Behavior When Changing Room Types** to prevent a room's label from displaying when an "Unspecified" room is assigned a different Room Type in its Room Specification dialog. When this box is checked, the room label's display will be enabled when the Room Type is changed from "Unspecified". See [General Panel on page 438](#).

### 4 Roofs

- Check **Automatically Place Roof Intersection Points** to automatically generate temporary CAD points that correspond to roof plane intersection points. When unchecked, these temporary points are not created. See [Locating Intersections on page 812](#).

### 5 Skylight Ceiling Hole Default

See [Skylights and Roof Holes on page 834](#).

- When **Skylights Automatically Generate Ceiling Holes** is selected, the program automatically generates a ceiling hole for a new skylight.
- Select **Manually Edit Ceiling Hole Polylines** to create your own ceiling holes.

## 6 Legacy File Configuration

Specify how obsolete settings are handled when legacy files are opened in the current program version. See *Considerations for Legacy Files on page 1411*.

- When **Opening Indicators Point to Hinge Side** is checked, the opening indicators for hinged openings point to the hinge side of the opening in legacy files opened in Chief Architect Premier X15. When unchecked, opening indicators in these files point to the handle side. See *Opening Indicators on page 549*.

## CAD PANEL

The CAD panel contains settings that define how CAD blocks, Sun Angles and other CAD and CAD-based objects behave.

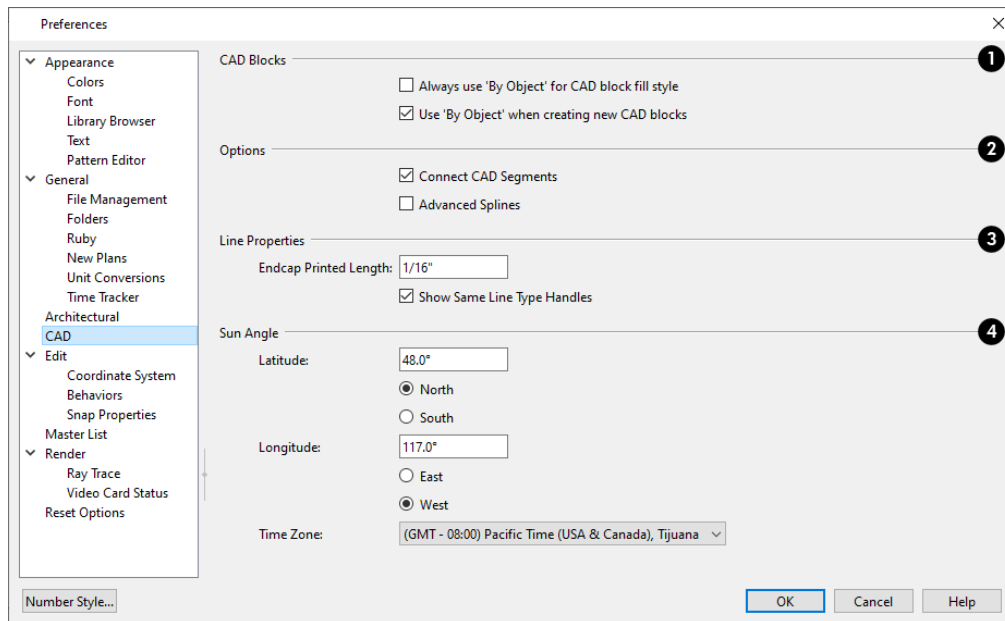

## 1 CAD Blocks

These settings affect how fill styles are applied to CAD blocks. See *CAD Blocks on page 329*.

- Check **Always use 'By Object' for CAD block fill style** to retain the fill patterns of the component objects of all CAD blocks, regardless of what is specified in a given CAD block's specification dialog. When this option is checked, the By Block Layer setting in the CAD Block Specification dialog only affects a CAD block's line style; any fill style settings are ignored entirely. See *CAD Block Specification Dialog on page 334*.
- Check **Use 'By Object' when creating new CAD blocks** to have **By Object** selected in the CAD Block Specification dialog when a new CAD block is created. See *General Panel on page 335*.

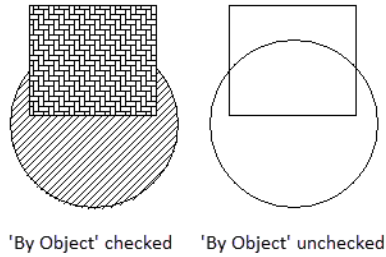

## 2 Options

- Uncheck **Connect CAD Segments**  to prevent CAD objects from snapping together to form polylines as they are drawn or edited. See [Connect CAD Segments on page 210](#).

Note: Unlike other Preferences, the program always resets Connect CAD Segments to be on whenever you close the program.

- Check **Advanced Splines** to enable the advanced spline setting as the default editing behavior for all subsequently drawn splines. You can also enable this function for an individual spline by clicking the **Advanced Splines**  edit button. See [Advanced Splines on page 237](#).

## 3 Line Properties

These settings affect open CAD shapes, including lines, arcs, and splines.

- **Endcap Printed Length** - The beginning and end of CAD lines that use a dashed line style are sometimes difficult to distinguish. Endcaps can be placed to eliminate this problem. Specify the printed endcap length in inches (mm).
- Uncheck **Show Same Line Type Handles** to turn off the display of these edit handles on selected CAD objects. See [Same Line Type Edit Handles on page 303](#).

## 4 Sun Angle

See [Sun Angles and Shadows on page 1143](#).

- Define the default **Latitude**, **Longitude** and **Time Zone** used when creating Sun Angles.

## EDIT PANEL

The settings on the EDIT panel of the Preferences dialog control the appearance of the cursor and selection behavior of edit handles. See [Using the Crosshairs on page 249](#).

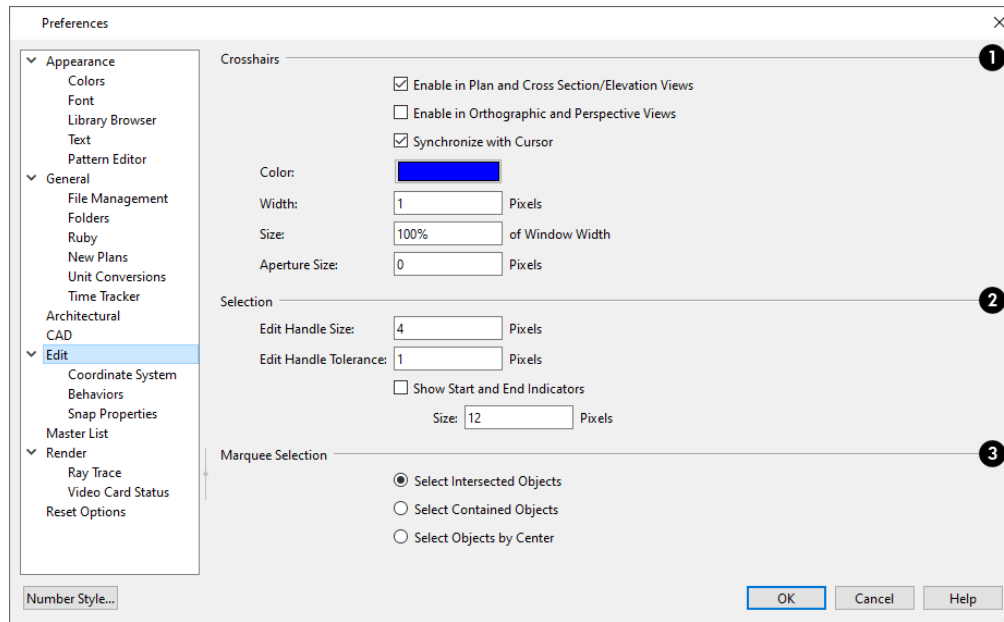

## 1 Crosshairs

You can use a cursor with Crosshairs in different view types and control its appearance. See [Crosshairs on page 16](#).

- Check **Enable in Plan and Cross Section/Elevation Views** to use a cursor with crosshairs in plan and cross section/elevation views. This option is checked by default.
- Check **Enable in Perspective Views** to use a cursor with crosshairs in perspective camera views and overviews.
- When **Synchronize with Cursor** is checked, the mouse pointer and crosshairs always move together on screen. If you feel that they do not keep up with your mouse movements, try unchecking this option.
- Click the **Color** bar to open the Select Color dialog and specify the color of the crosshairs.
- Specify the **Width** of the crosshairs lines, in pixels.
- Crosshairs **Size** is specified as a percentage of the view **Window Width**. Specify the **Size** as 100% to extend the crosshairs across the entire screen.
- Set the **Aperture Size**, measured in pixels. The aperture is the space where the crosshairs meet. A value of 0 makes the crosshairs meet at a point. Larger numbers leave a gap in the center.

## 2 Selection

Customize the appearance of some types of selected objects, and edit handle sensitivity.

- Enter an **Edit Handle Size** in pixels. The edit handles are twice this number of pixels plus one. For example, the default value is 4, which results in a handle that is 9 x 9 pixels ( $4 \times 2 = 8$ , and  $8 + 1 = 9$ ). The minimum value is 1, which results in a handle that is 3 x 3 pixels.
- Enter a value, in pixels, for **Edit Handle Tolerance** to specify how close to an edit handle you must click in order to select it. The default value is 0.
- Check **Show Start and End Indicators** to display an S and an E at the start and end points of a selected wall or the selected edge of a CAD-based object. This can make it easier to edit the selected edge in the object's specification

dialog. See [Selected Edge on page 212](#).

- Specify the **Size** of the Start and End Indicators, in pixels.

### 3 Marquee Selection

Specify program behavior when selecting objects using a marquee. See [Marquee Select on page 213](#).



**Select Intersected Objects** selects any objects whose bounding boxes are intersected by or located within the marquee. See [Bounding Boxes on page 983](#).



**Select Contained Objects** selects only objects located entirely within the marquee. This option provides the best results in most situations.



**Select Objects by Center** selects only objects whose center points are located within the marquee.

 You can add the Selection Modes tools to your toolbars. See [To add a button to a toolbar on page 132](#).

## COORDINATE SYSTEM PANEL

Indicators for the X, Y, and Z drawing space axes and/or the drawing space origin can be set to display in a variety of views for reference purposes. See [Coordinate System Indicators on page 145](#).

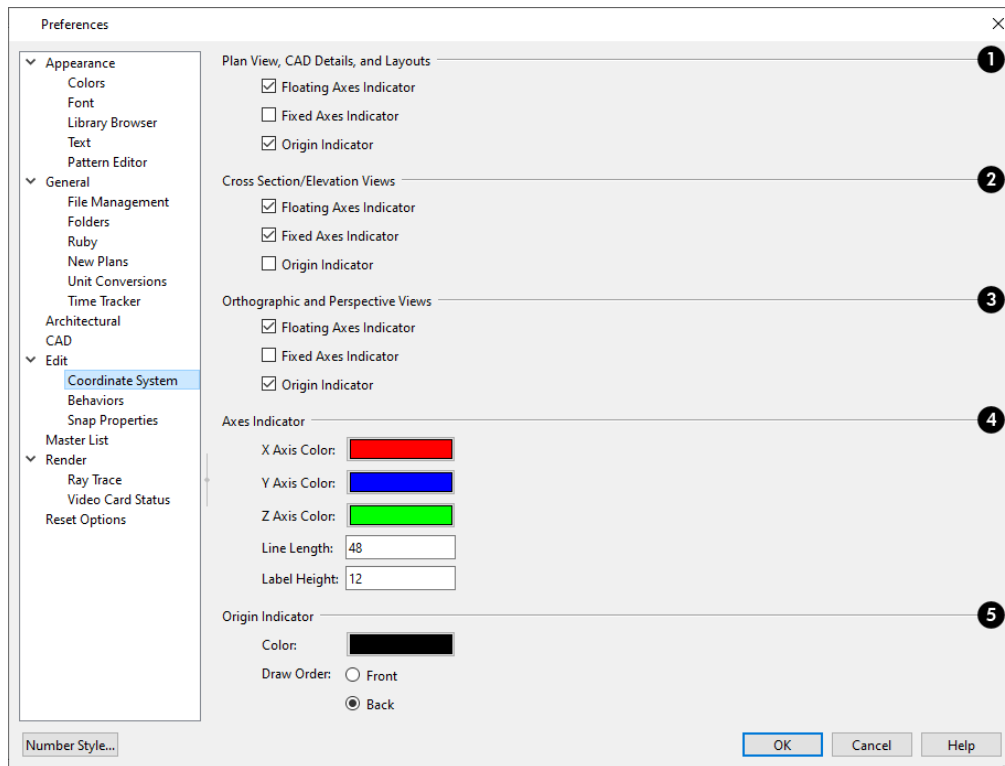

### 1 Plan View, CAD Details, and Layouts

Check the box beside each indicator type that you want to display in these view types. In these 2D views, the X and Y axes are always shown.

## 2 Cross Section/Elevation Views

Check the box beside each indicator type that you want to display in these view types. In these 2D views, the Z axis is always shown, and the other axis is dependent on the camera's direction. If the camera's line of sight is at an angle that is not parallel to either the X or Y axis in plan view, all three axes will be represented.

## 3 Orthographic and Perspective Views

Check the box beside each indicator type that you want to display in these view types. In these 3D views, the X, Y, and Z axes are always shown.

## 4 Axes Indicator

- The **X Axis**, **Y Axis**, and **Z Axis Colors** display in the Color bars. Click a Color bar to choose a new color if you wish. See [Color Chooser/Select Color Dialog on page 203](#).
- Specify the **Line Length**, which controls the size of the Floating Axis Indicator in all view types.
- Specify the **Label Height**, which controls the size of the X, Y, and Z axis labels in all view types.

## 5 Origin Indicator

- Specify the **Color** of the Origin Indicator crosshairs. See [Color Chooser/Select Color Dialog on page 203](#).
- Specify the Origin Indicator's **Draw Order**: select **Front** to draw the Origin Indicator in front of objects in the view, or select **Back** to draw it behind all objects in the view. See [Drawing Groups on page 190](#).

## BEHAVIORS PANEL

The settings on the BEHAVIORS panel of the Preferences dialog define basic editing behaviors of CAD and architectural objects.

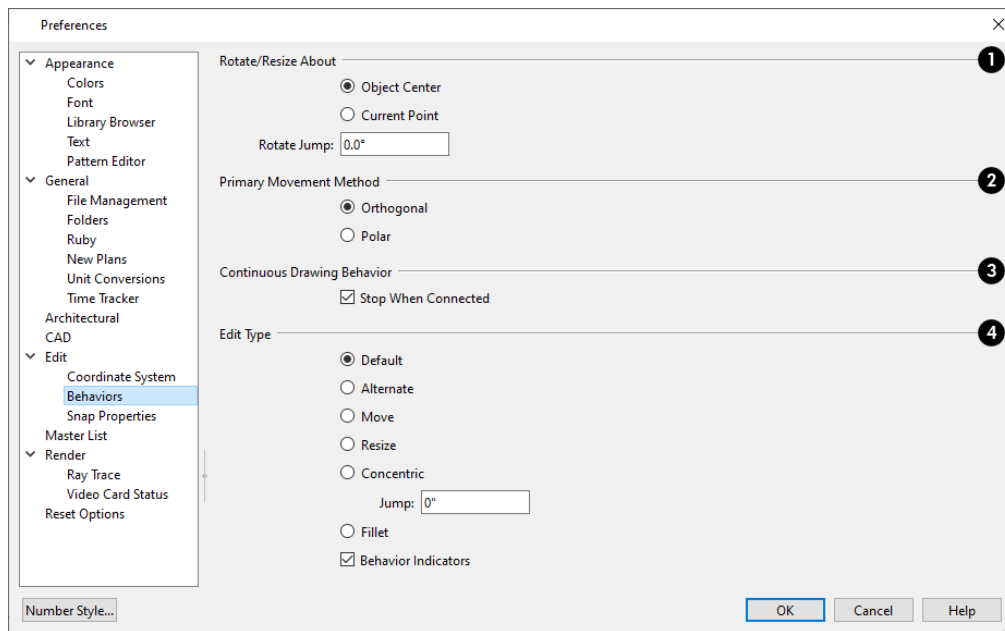

## 1 Rotate/Resize About

Define the point about which an object or a group of objects rotates or resizes. See [Rotate/Resize About on page 159](#).

- Select **Object Center** to rotate or resize the selection about its center point. Object Center is the default setting.
- Select **Current Point** to rotate the object about the current CAD point instead.
- To resize a CAD object about a current point, select the **Resize Edit Type**.
- This function can also be accessed by selecting **Edit> Edit Behaviors> Resize** . See [Defaults, Preferences, and Edit Behaviors on page 206](#).
- **Rotate Jump** defines the angles an object or group of objects jumps to as it is rotated. When this value is set to 0°, the Allowed Angles set in the Plan Defaults dialog are used; otherwise, Allowed Angles are ignored.

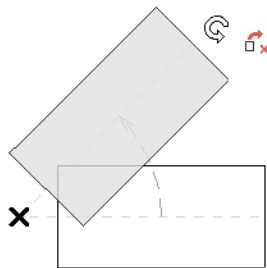

## 2 Primary Movement Methods

Control the directions that you can move objects using their edit handles.

- Select **Orthogonal** to move an object perpendicular to any of its edges.
- Select **Polar** to move an object at Allowed Angles.

## 3 Continuous Drawing Behavior

Specify whether the **Continuous Drawing Behavior** restarts after a closed shape is formed. See [Alternate on page 207](#).

- Uncheck **Stop When Connected** to remain in the continuous Alternate drawing mode after a closed shape is formed. When checked, the continuous drawing mode is halted but can be started again.

## 4 Edit Type

Specify the active Edit Behavior. See [Defaults, Preferences, and Edit Behaviors on page 206](#).

- If **Concentric** is selected, specify the desired **Jump** increment.
- Uncheck **Behavior Indicators** to turn off the display of the mouse pointer icons associated with these Edit Behaviors. This box is checked by default.

Note: Unlike other Preferences, the program always restores the Default Edit Behavior whenever you close the program.

## SNAP PROPERTIES PANEL

The settings on the SNAP PROPERTIES panel of the Preferences dialog control the behavior of Object Snaps as well as the appearance of snap indicators. See [Object Snaps on page 160](#).

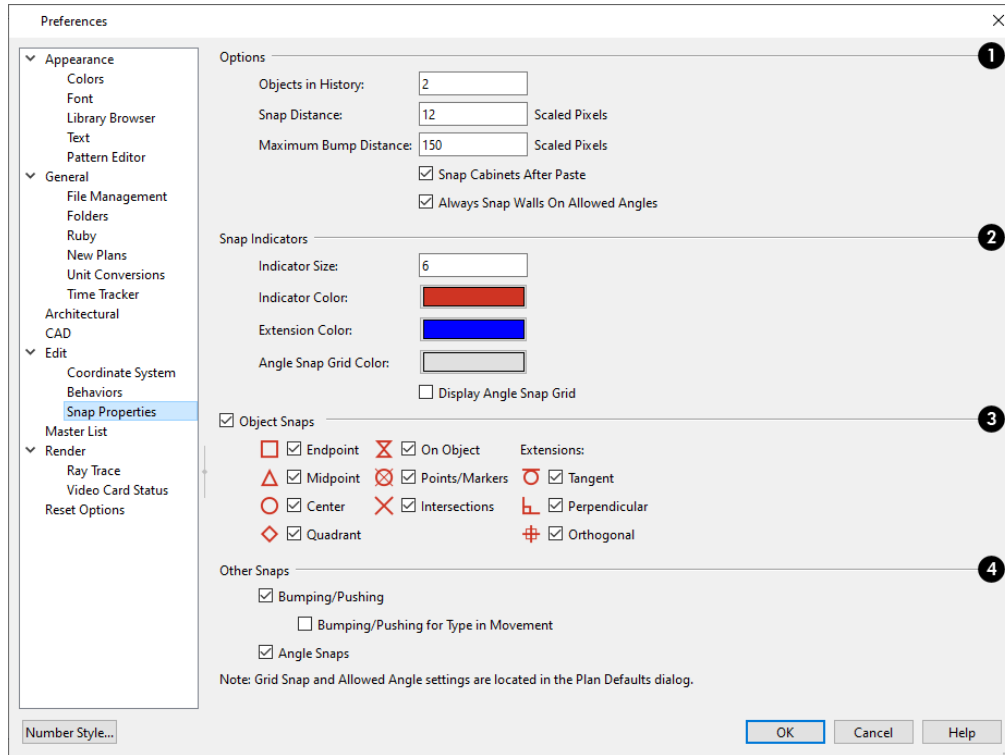

## 1 Options

- Specify the **Objects in History**, which is the number of Extension Line Anchors that can display at one time.
- Specify the **Snap Distance**, which is how far the cursor can be from a snap point for the snap to occur. This value is measured in scaled pixels; the default value is 12.  
When working with very small objects, you may find it helpful to reduce this value; when working with very large objects, it may be helpful to increase it.  
This setting also controls the minimum length of camera and cross section/elevation lines of sight. See [Creating Camera Views on page 1086](#).
- Specify the **Maximum Bump Distance**, which is the distance in scaled pixels that a selected object must be dragged to override bumping and move past an obstructing object.
- Check **Snap Cabinets After Paste** to make the cabinets snap together after you paste them.
- Check **Always Snap Walls on Allowed Angles** to limit walls to Allowed Angles. When unchecked, Object Snaps can override Angle Snaps, allowing walls to snap at off angles as they are drawn or edited. See [Angle Snaps on page 162](#).

## 2 Snap Indicators

- Specify a snap **Indicator Size** in pixels. This setting also controls the size of temporary CAD Points. See [Place Point on page 296](#).
- Click the color bar to select a snap **Indicator Color** from the Select Color dialog. See [Color Chooser/Select Color Dialog on page 203](#).
- Click the color bar to select an **Extension Color** from the Select Color dialog.



- Click the color bar to select an **Angle Snap Grid Color** from the Select Color dialog.
- Check **Display Angle Snap Grid** to turn on the display of the Angle Snap Grid. See [Angle Snap Grid on page 163](#).

### 3 Object Snaps

These options can also be turned on and off using the toggle buttons on the toolbar and/or keyboard hotkeys.

Check **Object Snaps** to enable the object snap and extension snap options, below.

- Endpoint** enables snapping to the ends of lines, arcs, splines and other objects.

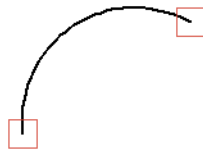

Endpoint snaps

- Midpoint** enables snapping to the midpoint of an object such as a line or arc. For objects such as boxes, you can snap to the midpoint of any side of the box.

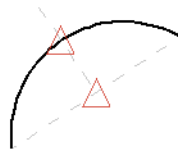

Midpoint snaps

- Center** enables snapping to the center of cabinets, fixtures, furniture, as well as circles and arcs.



Center snap

- Quadrant** enables snapping to the left, right, top, or bottom of an object. Only used for arcs and circles.

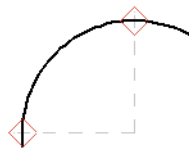

Quadrant snaps

- On Object** enables snapping to any point on the selected object, including CAD objects and cabinets.

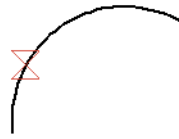

On Object snap



**Points/Markers** allows you to snap to temporary CAD points. Note that this only affects CAD Points, not Text Markers. See [Point Tools on page 296](#).



Points/Markers snap



**Intersection** enables snapping to the intersection of two objects, such as the intersection of a line with another line. Intersection snapping also snaps extension lines to objects, and allows you to snap two extension lines to each other.



Intersection snap

When Intersection snapping is enabled, wall extension line snapping will also occur. See [Creating Walls on page 357](#).

Check any combination of **Extension Snaps**.



**Tangent Extensions** enables snapping to a point tangent to the point where the extension anchor sits.

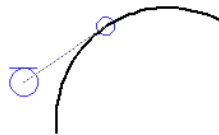

Tangent extension



**Perpendicular Extensions** enables snapping to a point perpendicular to the point where the extension anchor sits.

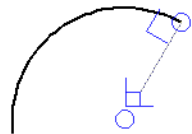

Perpendicular extension



**Orthogonal Extensions** enables snapping to a point on a 90° axis from the extension anchor.

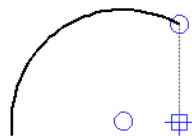

Orthogonal extension

## 4 Other Snaps



Check **Bumping/Pushing** to allow objects to bump into and move other objects. See *Bumping/Pushing on page 243*.

- Check **Bumping/Pushing for Type-in Movement** to cause objects moved using dimensions or the Enter Coordinates dialog to bump into objects in their path of movement and stop. When unchecked, objects moved using type-in methods move to their specified destination locations. See *Moving Objects on page 243*.



Check **Angle Snaps** to enable snapping to Allowed Angles. See *Angle Snaps on page 162*.

## MASTER LIST PANEL

The MASTER LIST panel specifies how the Master List(s) for materials appears. You can maintain Multiple Master Lists, but only one may be used at any given time. See *Materials Lists on page 1303*.

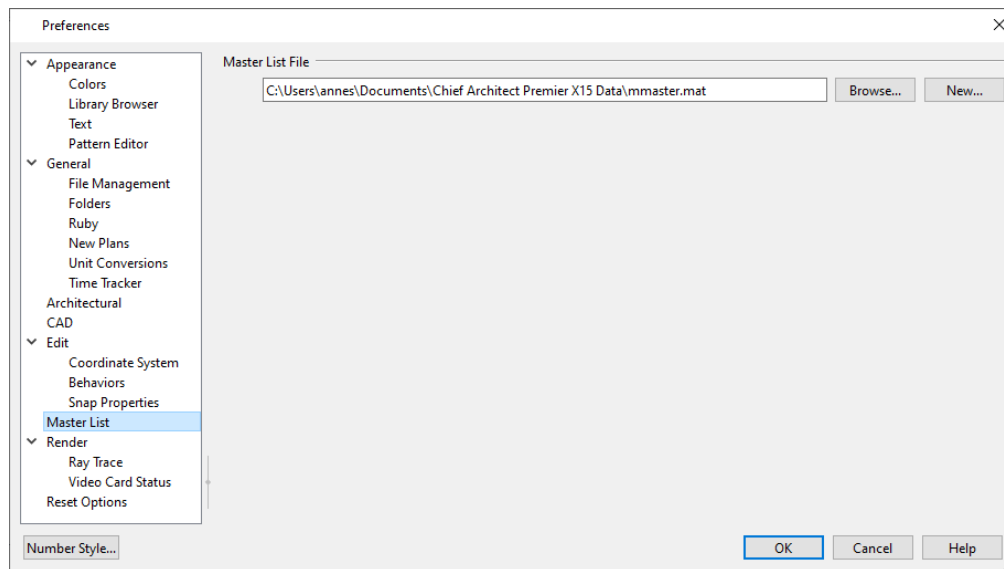

### Master List File

The name and pathname of the currently referenced Master List is shown. It is referenced for all subsequently opened plans when a materials list is generated.

- Click the **Browse** button to select a different Master List. Navigate the directory structure until you find the new Master List to be used, select it, and click **OK**.

Note: If the Master List file is saved in the program Data folder, and the location of My Data Folder is changed, this pathname will automatically update. See *Folders Panel on page 106*.

- Click the **New** button to create a new Master List. Name and save it in the location of your choice. When you create a new Master List, it is blank until you build a materials list and enter prices, supplier or manufacturer information. The Master List is saved automatically when you close.

## RENDER PANEL

The settings on the RENDER panel control how 3D views are generated and navigated.

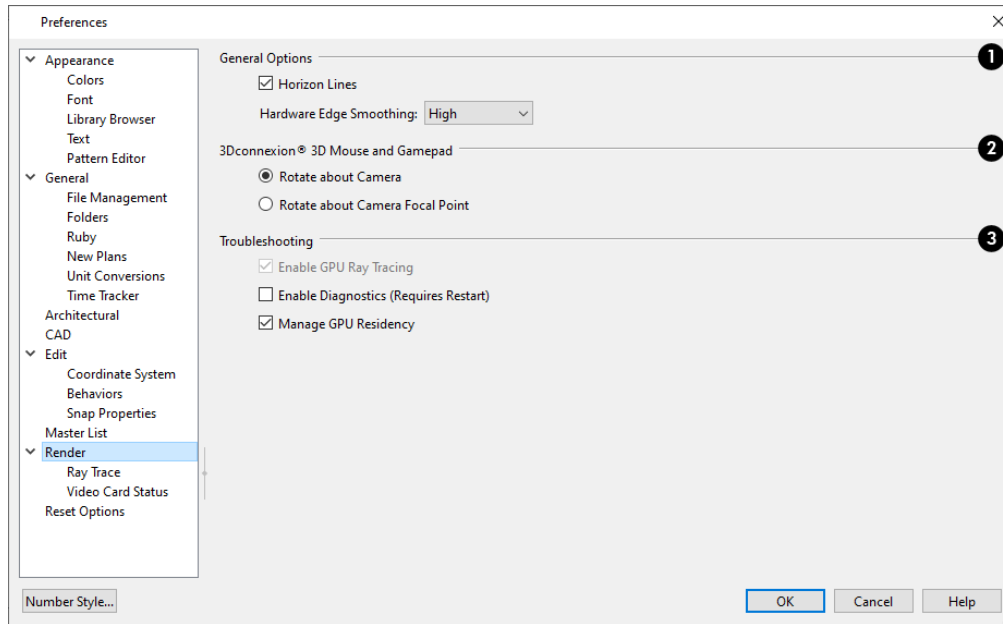

### 1 General Options

- **Horizon Lines** are lines that generate along the curved edges of symbol objects in Vector Views. Uncheck this box to increase the speed of Vector View generation but also suppress these lines. See [Vector View on page 1150](#).
- **Hardware Edge Smoothing** uses the video card to reduce the jagged appearance of angled surface edges and pattern lines, producing cleaner lines. The higher the smoothing effect, the longer the rendering time. See [Edge Smoothing on page 1134](#).

### 2 3Dconnexion® 3D Mouse and Gamepad

See [3Dconnexion® 3D Mice on page 1101](#).

- Select **Navigate about Camera** to center mouse movement about the location of the camera.
- Select **Navigate about Camera Focal Point** to center mouse movement about the location of the camera's focal point. See [To create a camera view on page 1086](#).

### 3 Troubleshooting

- In the Windows version of the program, uncheck **Enable GPU Ray Tracing** to disable real-time ray tracing in the Physically Based and Clay Rendering Techniques. This box is checked by default and should only be unchecked for troubleshooting purposes. If this option is disabled, it is not supported on the system. See [GPU Ray Tracing on page 1132](#).
- In the Windows version of the software, the **Enable Diagnostics (Requires Restart)** option makes it possible for information about certain errors to be collected. Restarting with Diagnostics enabled will degrade program performance and should only be done when requested Chief Architect Technical Support. See [Contacting Technical Support on page 1405](#).

- **Manage GPU Residency** helps improve performance when printing very large files. This option is checked by default and should only be unchecked for troubleshooting of printing issues in the Windows version of the software only. See [Printing and Plotting on page 1363](#).
- In the Mac version of the software, checking **Disable Render Target Aliasing** may address pixelation in camera views. This option is unchecked by default on most systems.
- In the Mac version of the software, the **Enable Retina Render Targets** option is checked by default but should be unchecked on systems that do not have Retina displays.

## RAY TRACE PANEL

The settings on RAY TRACE panel allow you to specify how much of your computer's processor resources to allocate to the Chief Architect Ray Tracer. Changes to these settings do not affect ray traces that are in progress or queued: only ray traces that you start in the future. See [CPU Ray Tracing on page 1167](#).

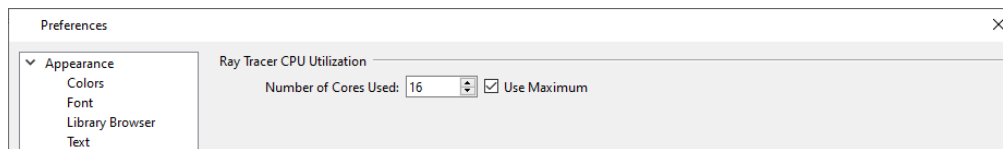

- Specify the **Number of Cores Used** by typing in the text field or clicking the up or down arrows. The number of cores available will vary, depending on the number of cores your system has and whether it uses hyper threading.
- Check **Use Maximum** to use the highest number of cores available on the system.

## VIDEO CARD STATUS PANEL

The VIDEO CARD STATUS panel displays information about your video card, including the vendor and whether it supports the software's minimum requirements.

This information may be important if you are having problems generating 3D views.

## RESET OPTIONS PANEL

In order for some of the Reset Options to take effect, you will need to restart Chief Architect.

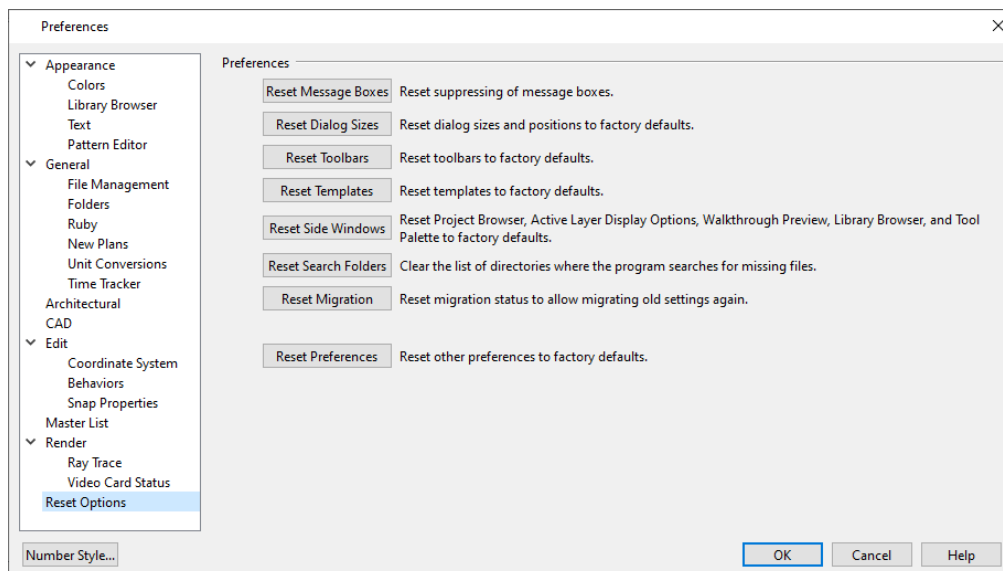

- If message boxes have been suppressed, you can make them display again by clicking **Reset Message Boxes**. See [Message Boxes on page 25](#).
- Click the **Reset Dialog Sizes** button to restore all dialog boxes to their original sizes and positions. See [Dialogs on page 19](#).
- Click the **Reset Toolbars** button to reset all toolbars to their original states. If you are encountering warning messages regarding toolbars, this option may resolve the issue. Note that any custom toolbar configurations that you may have created will be discarded if you click this button. See [Creating Custom Toolbar Configurations on page 133](#).
- Click the **Reset Templates** button to restore the templates used for creating new plan and layout files. Any custom template files saved in the user Templates folder will not be affected by this action. See [Template Files on page 87](#).
- Click the **Reset Side Windows** button to restore all side windows to their original sizes and positions. Side window Settings  are also reset, as are the panes in the Library Browser. See [Side Windows on page 17](#).
- Chief Architect retains a list of locations where you have located missing files in the past. If you find that the program takes a long time searching before informing you that files are missing, you can click the **Reset Search Folders** button to clear this list. See [Linked and Referenced Files on page 51](#).
- Click the **Reset Migration** button to be prompted to migrate your content and settings from an older program version the next time you launch the software.
- Click the **Reset Preferences** button to restore all preferences to those originally installed with the program.

 Resetting all preferences to default can be a drastic step and should be done with caution.

## Dialog Number/Angle Style Dialog

At the bottom of many dialogs, you can click the **Number Style** button to open the Dialog Number/Angle Style dialog.

The settings in this dialog are global and control the format of distances, coordinates and angles of angles in dialog boxes and inline text fields, as well as in the Status Bar. They are also persistent for the current program session only: when you restart the program, they are reset. See [The Status Bar on page 24](#).

These settings control the format of values used in dialogs but do not limit how you must enter these values. For example, if you set your Number Style to use Inches, values will display using fractional inches. You can, however, enter values using decimal inches, inches and feet, or even decimal feet by including the appropriate unit indicators. When the dialog you're typing in updates, the value will be converted to fractional inches.

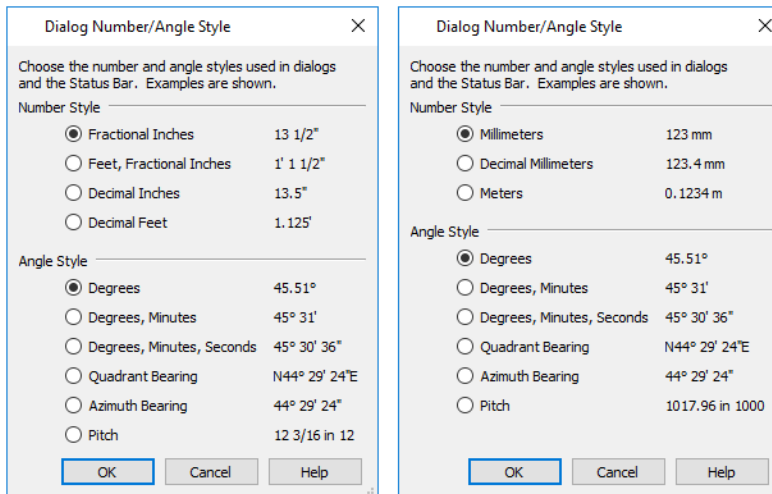

When U.S. Units are used, the **Fractional Inches** and **Feet, Fractional Inches** options use fractional inches with denominators of 2, 4, 8 and 16. A few objects, notably text, dimensions, and floor, ceiling and wall structure layers can be sized using smaller fractions with larger denominators.

Angles can be displayed using one of the following methods:

- **Degrees/Minutes/Seconds** - Measured counterclockwise from a line drawn horizontally to the right of the angle's vertex. Useful for most drawing tasks. Select the level of accuracy that you require.
- **Quadrant Bearings** - Measured from a vertical line representing North/ South, Quadrant Bearings use directional bearings in their measurements. Useful for site drawings.
- **Azimuth Bearings** - Measured from a line drawn straight up from the angle's vertex (ie, North on a site plan). Useful for site drawings, Azimuth Bearings use degrees, minutes, and seconds in their measurements.
- **Pitch** - Defined as a ratio of vertical rise to horizontal run. In U.S. Unit plans, the run is always 12"; in metric plans, it is 1000 mm. Useful for roofs.

Quadrant and Azimuth Bearings are affected by the orientation of the **North Pointer** , if one is present in the current plan. See *North Pointer* on page 1143.

# Toolbars and Hotkeys

## Chapter 5

Two of the most efficient ways to access Chief Architect’s tools and settings are the toolbars and keyboard shortcuts, also referred to as hotkeys.

Both toolbars and hotkeys can be customized to suit your workflow.

### TOPICS

<b>Toolbar Arrangement</b> .....	<i>129</i>
<b>Customizing Toolbars</b> .....	<i>131</i>
<b>Creating Custom Toolbar Configurations</b> .....	<i>133</i>
<b>Toolbar Customization Dialog</b> .....	<i>134</i>
<b>Hotkeys</b> .....	<i>137</i>
<b>Exporting and Importing Hotkeys</b> .....	<i>139</i>
<b>Gamepad Settings Dialog</b> .....	<i>140</i>



## Toolbar Arrangement

Chief Architect’s toolbars provide fast access to the program’s most commonly used tools and settings, and are organized so that related tools are grouped together and easy to find.

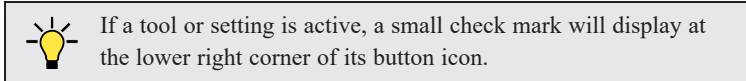

The toolbars that display in a given view depend on the view type. For example, the toolbars that are available in floor plan and 3D views are not available in Materials Lists or CPU Ray Trace views. Some toolbars are available in more than one type of view. If a tool cannot be used in that view, its icon will appear pale grey in color.

You can turn off the display of toolbars entirely or turn them on again by selecting **View> Toolbars**

Many of Chief Architect’s tools are organized into families of related tools which can be accessed using either of two styles of toolbar interface: the **Child Tool Palette** or **Drop Down** tools. You can select the interface that you prefer in the Preferences dialog. See [Appearance Panel on page 95](#).

### DROP-DOWN TOOLS

Click on the arrow to the right of a button to display a drop-down list of related tools. For example, click the arrow to the right of the **Window** button to display a drop-down list of the other Window Tools.

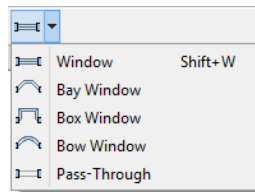

The most recently selected tool displays in the toolbar.

### CHILD TOOL PALETTE

An alternative to Drop-Down toolbars is the Parent button and Child Tool Palette interface. Parent toolbar buttons have a blue triangle in the lower right corner. When you select a Parent button, its Child tools display in the Child Tool Palette. If the Child Tool Palette has been closed, it will open.

By default, the Child Tool Palette is docked on the left side of the program window; but it can be undocked and moved, as well as resized and closed, just like other side windows. See [Side Windows on page 17](#).

As long as it is open, the Child Tool Palette will also display the members of a selected tool’s family when the Drop Down interface is active. If you select a tool that does not belong to a family, the previously selected tool’s family will continue to display in the Tool Palette.

When you click the **Window Tools** Parent button, for example, its Child buttons display in the Child Tool Palette.

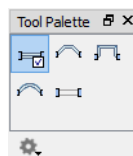

Click the **Settings**  button at the bottom of the palette to select how the tools within it are presented:



**Fit Palette:** resize the palette so that it is one row wide.



**Grid View:** display only the button icons of the child tools in a grid that may have multiple rows, depending on the width of the palette side window.



**List View:** display child tools in a vertical list with each tool's button icon and name in a row.

You can open the Tool Palette at any time, even when Drop Down tools are enabled, by selecting **View> Tool Palette** .

See *View Tools on page 152*.

## DROP-DOWN CONTROLS

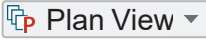
In addition to tool and setting buttons, there are a number of drop-down controls  **Plan View** that let you choose between a selection of layer and active default settings, and can be added to your toolbars:



**Saved Plan View Control** - See *Plan Views on page 146*.



**Active Layer Set Control** - See *Activating a Layer Set on page 182*.



**Active Dimension Defaults Control** - See *Saved Dimension Defaults on page 450*.

Saved Plan Views and Default Sets allow you to quickly switch layer sets and activate multiple saved defaults at once:



**Active Default Set Control** - See *Activating a Default Set on page 84*.

## THE EDIT TOOLBAR

The Edit Toolbar is a special toolbar that only features buttons when one or more objects in the drawing window is selected. By default, it is located at the bottom of the program window, just above the Status Bar. The buttons on this toolbar vary, depending on the type of object selected, the current view, and how you selected the object; when no object is selected, it is blank.



## TOOLBAR CONFIGURATIONS

Chief Architect installs a set of Toolbar Configurations, which control what tools are initially included in the toolbars, as well as where these toolbars are located.



The **Default Configuration** displays architectural tools used for house design, including walls, windows, doors, stairs, cabinets, etc.



The **Terrain Configuration** displays buttons associated with the terrain and road tools, including the plant and sprinkler tools. See *Terrain Toolbar Configuration on page 1244*.



The **Space Planning Configuration** displays buttons associated with the Space Planning Assistant. See *Space Planning on page 62*.



The **Extended Configuration** displays an extensive selection variety of tools for various uses.

### ***To switch toolbar configurations***

There are several ways to switch from one Toolbar Configuration to another.

- Click a Toolbar Configuration button.
- Choose a configuration in the Toolbar Customization dialog. See [Configurations Panel on page 136](#).
- Right-click in an empty space on any toolbar and select a **Toolbar Configuration** from the contextual menu.

### **TOOLBAR BUTTON SIZE**

By default, toolbar buttons are sized at 20 pixels, which works well on most computer monitors running default system settings. If you wish, you can increase or decrease this size in the Preferences dialog. See [Appearance Panel on page 95](#).

---

## **Customizing Toolbars**

The Toolbar Configurations installed with the program are designed to help make tools quickly and easily accessible; however, for greatest efficiency, you may want to customize them to meet your own particular needs. A number of options are available:

Any changes made to an existing Toolbar Configuration will be saved whenever you:

- Switch to a different configuration;
- Close the Toolbar Configuration dialog;
- Exit out of Chief Architect.

Bear in mind that the size of the Chief Architect program window and the space available for toolbar button depends on your monitor's size and screen resolution settings.

### **TOGGLING TOOLBARS**



You can turn off the display of all toolbars entirely or turn them on again by selecting **View> Toolbars**.

There are also several ways to toggle individual toolbars on or off:

- Right-click in an empty space on any toolbar and mouse over **Toolbars** in the contextual menu. In the submenu, toolbars with a check mark next to their name are on in the current view. Click on a toolbar name to turn it off if it is on, or vice versa.
- Toolbars can be turned on or off in the Toolbar Customization dialog. See [Toolbar Panel on page 135](#).
- If a toolbar is undocked, click the **Close** button at its top right corner.

### **MOVING TOOLBARS**

You can move any toolbar to a different location by clicking and dragging its dotted grab bar. Toolbars can be docked to any side of the program window, or they can be undocked and left floating.

Undocked toolbars can be moved outside the program window, and they can be closed completely. They can also be reshaped; however, they cannot be resized in such a manner that any buttons become hidden.

Changes to toolbars are saved between program sessions.

## ADDING AND REMOVING BUTTONS

Toolbar buttons can be added to or removed from toolbars using the Toolbar Customization dialog.

### *To add a button to a toolbar*

1. Select **Tools> Toolbar and Hotkeys> Customize Toolbars**  and go to the TOOLS panel of the Toolbar Customization dialog. See [Tools Panel on page 134](#).
2. Select the **View Type** that you want to add a toolbar button in.
  - You can add any buttons you like to any View Type; however, not all buttons will necessarily be available for use in all views.
3. Search or browse to find the desired button or its parent in the **Available Toolbar Buttons** list.
4. Click and drag the button you wish to add to a toolbar out of the dialog box.
  - Drop it onto an existing toolbar to add the button to that toolbar.
  - Drop it away from an existing toolbar to create a new toolbar. See [To create a new toolbar on page 132](#).

To remove a button from a toolbar, open the Toolbar Customization dialog, then click and drag the button out of the toolbar area.

Buttons cannot be added to or removed from the Edit Toolbar. See [The Edit Toolbar on page 130](#).

## ADDING AND REMOVING TOOLBARS

Toolbars can be added to or removed from each View Type using either the toolbar contextual menu or the Toolbar Customization dialog.

### *To add or remove an existing toolbar*

1. Right-click on an empty space in a toolbar.
2. In the contextual menu, click on the name of a toolbar.
  - If the toolbar has a check mark next to it, clicking on it will clear the check mark and remove the toolbar from the current View Type.
  - If the toolbar does not have a check mark next to it, clicking on it will add the toolbar to the current View Type.

You can also specify which toolbars are used in each View Type in the Toolbar Customization dialog. See [Toolbar Panel on page 135](#).

## CREATING NEW TOOLBARS

New toolbars can be created using the Toolbar Customization dialog.

### *To create a new toolbar*

1. Select **Tools> Toolbar and Hotkeys> Customize Toolbars**  and go to the TOOLS panel of the Toolbar Customization dialog.
2. Select the **View type** to which you want to add a new toolbar.
3. Select the first button that you want on the toolbar from the **Available Toolbar Buttons** list.
4. Click and drag the button out of the dialog box and drop it:

- In an empty section of the program window border to create a new toolbar docked at that location.
  - In the drawing area to create a new, undocked toolbar.
5. Additional buttons can be added by dragging them onto to this new toolbar.

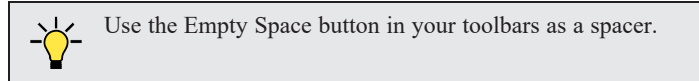

6. A new toolbar will inherit the name of the first tool that was added to it, preceded by the word Custom. You can assign a new name on the TOOLBAR panel of the Toolbar Customization dialog.
7. Also on the TOOLBAR panel, specify the View Types that the new toolbar should be used in.

## LOCKING TOOLBARS



When your toolbars are organized the way you want them, you can select **Tools > Toolbars and Hotkeys > Lock Toolbars** to prevent them from being moved. Select the same tool to unlock toolbars. **Lock Toolbars** is also available in the contextual menu for toolbars: right-click in an empty space on any toolbar to access it. See [Contextual Menus on page 19](#).

## RESTORING TOOLBARS

To discard your changes and restore all installed Toolbar Configurations to their original condition, click the **Reset Toolbars** button in the Toolbar Customization dialog. See [Toolbar Panel on page 135](#).

Because resetting toolbars affects all installed Toolbar Configurations, you may find it worthwhile to create your own custom Toolbar Configurations. See [Creating Custom Toolbar Configurations on page 133](#).

You can also restore toolbars to their original state in the Preferences dialog; however, please note that if toolbars are restored using this option, any custom configurations that you have created will be discarded. See [Reset Options Panel on page 125](#).

---

# Creating Custom Toolbar Configurations

If you extensively edit your toolbars, consider creating one or more custom Toolbar Configurations so that your changes can be backed up as well as transferred to a different computer if you wish.

### *To create a custom configuration*

1. Go to the CONFIGURATIONS panel of the Toolbar Customization dialog. See [Configurations Panel on page 136](#).
2. Select a configuration similar to the one you want to create and click **Copy**.
3. Give the new configuration a short, unique name. It will be saved in the Chief Architect Premier X15 Toolbars folder. See [Chief Architect Premier Data on page 37](#).
4. When you click OK, the new configuration will appear in the list, and it will be active.
5. On the TOOLBARS panel, select each of the different **View Types** to see the toolbars active in each and confirm that they suit your needs.
6. You can now move toolbars, add or remove buttons, and add or remove toolbars to meet your requirements.
7. When you are satisfied with your new Toolbar Configuration, click **Close**.



It is a good idea to back up your custom Toolbar Configurations files. See *Chief Architect Premier Data on page 37*.

## CUSTOM CONFIGURATION BUTTONS

By default, new Toolbar Configurations display a default configuration  button; however, if you want you can make your own button icon for your custom Toolbar Configuration.

Create a **.png** file with the same name as the configuration and save it in the Toolbars folder. To see an example, look at the Default **.png** file in the Chief Architect Premier Toolbars folder, which corresponds to the Default Toolbar configuration. See *Chief Architect Premier Data on page 37*.

- Toolbar button images must be 20 x 20 pixels in size.
- The color (R:192, G:192, B:192) maps to the system 3D face color.
- The color (R:128, G:128, B:128) maps to the system 3D Shadow color.
- The color (R:223, G:223, B:223) maps to the system 3D light color.

## IMPORTING CUSTOM CONFIGURATIONS

Toolbar Configurations can be imported into the program, allowing you to transfer custom configurations between computers as well as add backed up configurations to new installations.

### *To import a custom configuration*

1. Go to the Configurations tab of the Toolbar Customization dialog.
2. Click **Add**.
3. Browse to the location of the toolbar you want to import.
4. Click **Open**. If the **.toolbar** file is not in the Chief Architect Premier X15 Toolbars folder, a copy of the file will be created there.

---

# Toolbar Customization Dialog



Select **Tools > Toolbars and Hotkeys > Customize Toolbars** to open the Toolbar Customization dialog. You can also right-click in an empty space in any toolbar and select **Customize Toolbars** from the contextual menu.

In the Toolbar Customization dialog, you can:

- Add and remove buttons from toolbars.
- Specify which toolbars display in different view types.
- Select the active Toolbar Configuration.

The Toolbar Customization Specification dialog has the following panels:

## TOOLS PANEL

From the TOOLS panel, you can add or remove buttons from your toolbars, as well as create new toolbars.

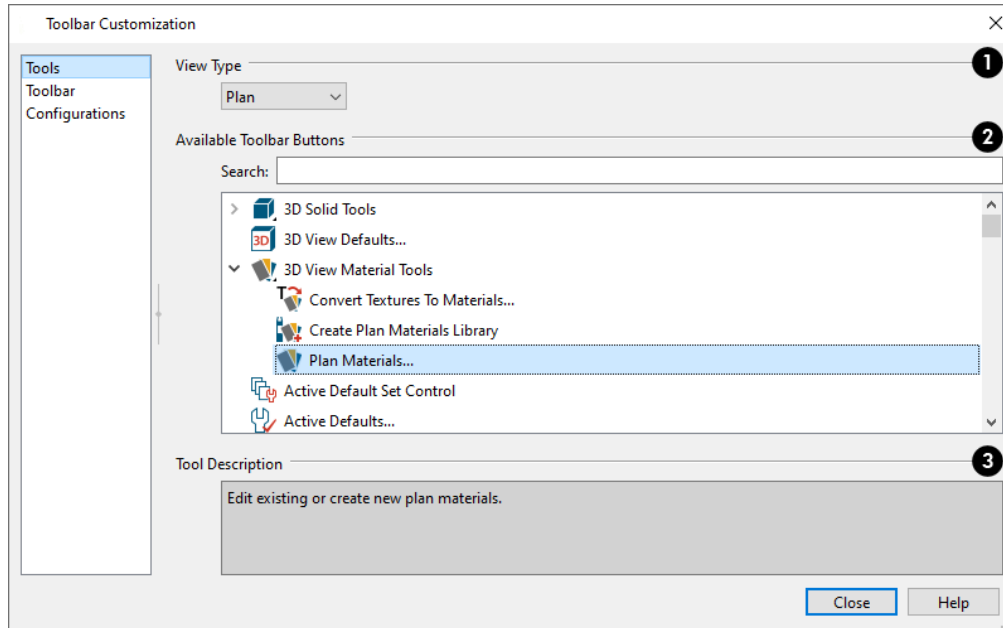

### 1 View Type

Select the **View Type** that you would like to add toolbar buttons to. When the dialog is first opened, the selected View Type is that of the current view. If you select a different View Type, the toolbars associated with it will display behind the dialog for reference until you click the **Done** button.

### 2 Available Toolbar Buttons

The **Available Toolbar Buttons** display in a list that can be searched or browsed.

- Type a keyword or the name of a tool in the **Search** field. As you type, only buttons that match your search will display.  
When nothing is typed in this field, all buttons will display in the list.  
If a child tool matches your search, its parent will display in the search results. Click the arrow next to the parent's name to see the child tools.
- The Available Toolbar Buttons list can be browsed using the scrollbar to the right.
- Click on a button in the list to display a description of that tool, below.
- Parent tools have an arrow to the right of their button icon in the list. Click on this arrow to display the child tools below the parent. See *Toolbar Arrangement on page 129*.

If you do not see a particular button in the list, it may be the child of a parent tool.

### 3 Tool Description

When a button is selected in the list above, a description of it displays here.

## TOOLBAR PANEL

The **TOOLBAR** panel allows you to manage the use of individual toolbars.

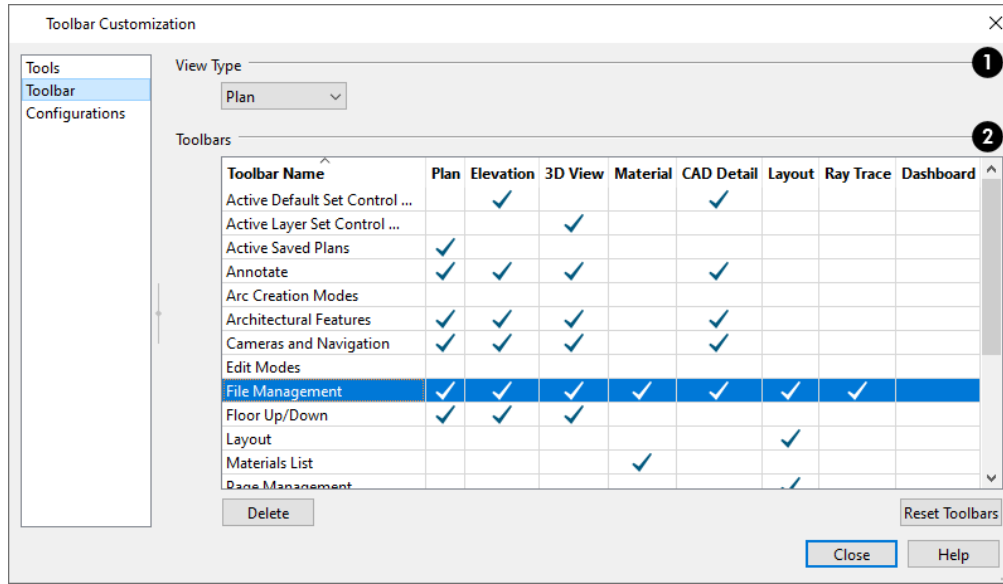

### 1 View Type

When this dialog is first opened, the selected **View Type** is that of the current view. If you select a different View Type, the toolbars associated with it will display behind the dialog for reference until you click the **Done** button.

### 2 Toolbars

The **Toolbars** table displays the names of all available toolbars, along with the View Types in which they are in use.

- Select a toolbar by clicking on its name.
- Click to place a check mark in a column to add the selected toolbar to that View Type; click on check mark to remove it.
- Double-click on a toolbar in the Toolbar Name column to rename it. Toolbar names must be unique.
- Click **Delete** to remove the selected toolbar from the list. A deleted toolbar is no longer available in any View Type.
- Click **Reset Toolbars** to restore all the toolbars to their original configuration. See *Restoring Toolbars on page 133*.

 Clicking the Reset Toolbars button removes all changes that you may have made to all installed Toolbar Configurations.

## CONFIGURATIONS PANEL

The CONFIGURATIONS panel allows you to add, remove, and switch between Toolbar Configurations. See *Toolbar Configurations on page 130*.



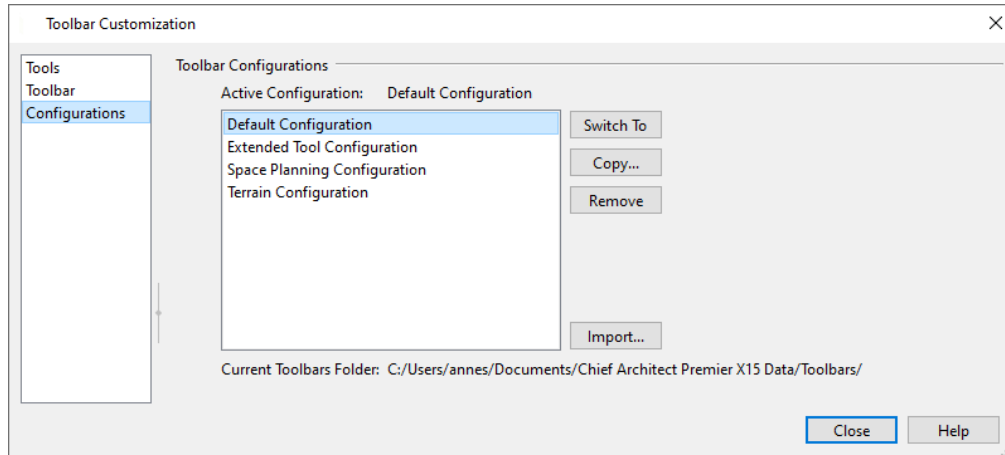

A list of Toolbar Configurations displays here. Select a configuration before clicking the **Remove**, **Copy**, or **Switch To** buttons.

- Click **Switch To** to switch to the selected Toolbar Configuration, making it active. See *To switch toolbar configurations on page 131*.
- Click **Copy** to create a copy of the selected Toolbar Configuration.
- Click **Remove** to remove the selected Toolbar Configuration. This removes the configuration from the list but does not delete the configuration file permanently. If only one configuration is listed, it cannot be deleted.
- The location of the **Current Toolbars Folder** displays below. See *Chief Architect Premier Data on page 37*.

---

## Hotkeys

Many Chief Architect tools have a keyboard shortcut, or hotkey, associated with them. If such a hotkey exists, it will display to the right of the tool's name in the menu.

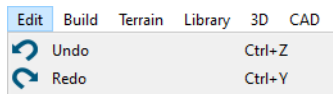

To use a hotkey, simply press the appropriate key or combination of keys on your keyboard instead of selecting the menu item or clicking the toolbar button. For example, press the Ctrl and Z keys at the same time to perform an **Undo** .

Note: If a key or key combination is in use as a system hotkey, it cannot be used as a program hotkey.

You can specify the hotkeys associated with Chief Architect tools in the Customize Hotkeys dialog. In this dialog, you can program hotkeys to activate tools and invoke a variety of commands such as opening dialogs, including Defaults dialogs.

Number keys can be, and are, used as hotkeys. Bear in mind that if a number key is assigned as a hotkey, the corresponding number pad key will invoke the same command as long as it is not assigned to something else. The converse, however, is not true: if a number pad key is assigned as a hotkey, the corresponding number key will not invoke that command.

### CREATE HOTKEY LIST

A list of the hotkeys available to the current program user can be saved in **.html** or **.xhtml** format.

Select **Tools > Toolbars and Hotkeys > Create Hotkey List** to open the Save Hotkey List File dialog, a standard Save dialog, and create a hotkey list that can then be opened in a web browser window and printed, if you wish.

## NEXT/LAST COMMAND

You can navigate a list of up to 100 recently used tools using the **Cancel Selection/Previous Command**, **Next Command** and **Previous Command** hotkeys. The tools in this list are organized according to the order in which you selected them during the current program session.

**Cancel Selection/Previous Command**, **Next Command** and **Previous Command** are hotkeys only: they do not have toolbar buttons associated with them and are not found in the menu.

By default, **Cancel Selection/Previous Command** is assigned to the Esc key. This command can be used to:

- Cancel a current object selection.
- Cancel a current drawing or editing action that is in progress.
- Activate the previously used tool or command if no object is selected or action in progress.



When canceling a selection or a command, be careful to press the Esc key only once to avoid changing the currently active tool.

By default, **Next Command** is assigned to the Shift+Esc keys. This command can be used to deactivate the current command and instead activate the one that is next in the list of recently used tools.

If you prefer, you can assign two different hotkeys to the **Cancel Selection** and **Previous Command** instead of one single hotkey.

## CUSTOMIZE HOTKEYS DIALOG



Select **Tools > Toolbars and Hotkeys > Customize Hotkeys** to open the Customize Hotkeys dialog.

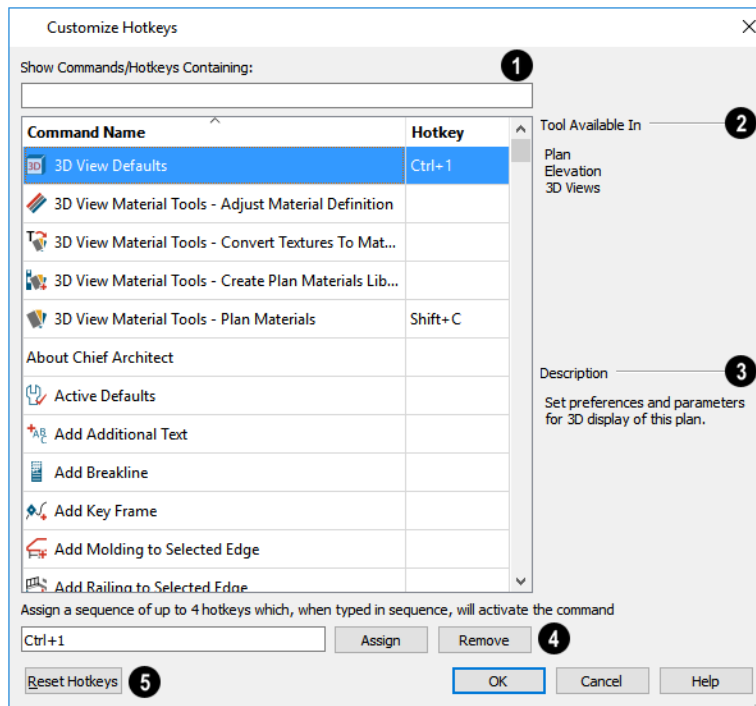

### 1 Show Commands/Hotkeys Containing

- Click on an item in the list of **Command Names** and **Hotkeys** to select it.
- To filter the list, type part or all of a tool name or hotkey in the Search field, above. As you type, the list below will be filtered to only show items with either a Command Name or Hotkey that contains what you have typed.

### 2 Tool Available In

A list of the View Types that the selected command can be used in displays here.

### 3 Description

A brief **Description** of the selected command displays here.

- Click on an item in the list of **Commands** and **Hotkeys** to select it.

### 4 Edit hotkey for this command

Click in this field, then press the key or key combination that you would like to use.

- Create a simultaneous hotkey combination by holding down the Shift, Ctrl, and/or Alt keys and typing an additional letter or number.
- Create a hotkey sequence by typing up to four hotkeys or hotkey combinations, one after the other.

Note: Default hotkeys use the number keys and number keypad interchangeably. User defined hotkeys, however, do not. As such, when a custom hotkey is defined here, characters typed using the numpad begin with “Num +” in Windows, and “Num” on a Mac.

Bear in mind that while nearly all commands can be assigned custom hotkeys, a few cannot: Delete and Enter Coordinates are two notable examples. Hotkeys reserved by the operating system cannot be used, either.

### 5 Reset Hotkeys

Click the **Reset Hotkeys** button to restore the default hotkeys that were originally installed with the program.

---

## Exporting and Importing Hotkeys

Customized hotkeys are user specific and are saved in the Chief Architect Premier X15 Data folder. See *Chief Architect Premier Data on page 37*.

Hotkeys can be exported, making them available for import on another computer, or even by another user on the same computer.

### EXPORTING HOTKEYS

 To export hotkeys, select **File> Export> Hotkeys**. The Export Hotkeys dialog is a typical Save As dialog that lets you specify the exported file’s name and its saved location on your computer. See *Exporting Files on page 41*.

Exported hotkey files use the **.xml** file format. Information exported includes both customized hotkeys and hotkeys installed with the program.

## IMPORTING HOTKEYS

 To import hotkeys, select **File> Import> Hotkeys**. The Import Hotkeys dialog is a typical Open File dialog. See [Importing Files on page 45](#).

When hotkeys are imported, the existing User Hotkeys.xml file is replaced by the imported data. Any previously programmed custom hotkeys will not be retained.

## Gamepad Settings Dialog

 The Gamepad Settings dialog allows you to map gamepad buttons to commands and specify thumbstick behavior in Chief Architect. Select **Tools> Toolbars and Hotkeys> Customize Gamepad** to open this dialog. See [Gamepads on page 1101](#).

You can also open this dialog by clicking the Gamepad Settings button, which you can add to your toolbars. See [To add a button to a toolbar on page 132](#).

You can also specify whether navigation is centered about the location of the camera or its focal point in the Preferences dialog. See [Render Panel on page 124](#).

## BUTTONS PANEL

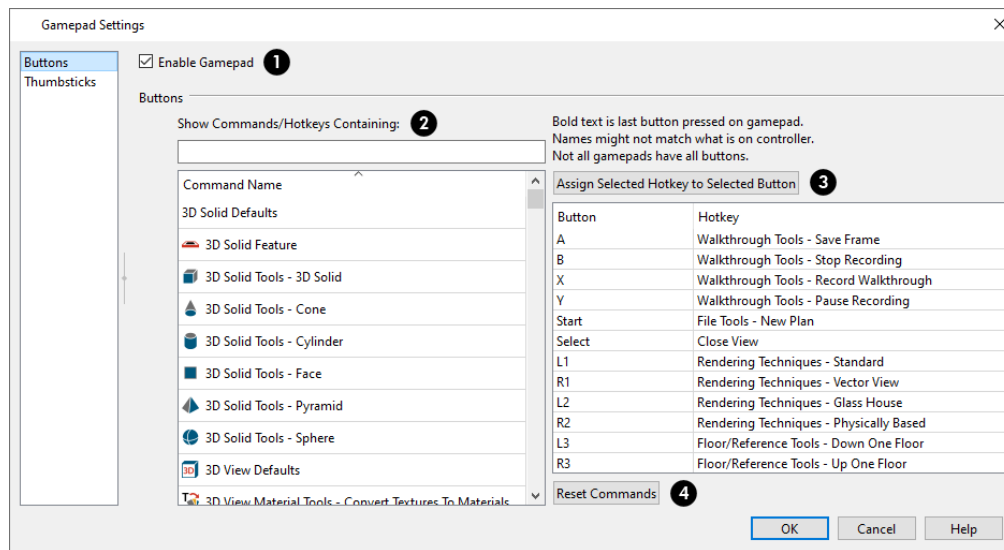

### 1 Enable Gamepad

Check this box to allow Chief Architect to recognize a gamepad on your system and enable the other settings in this dialog.

### 2 Command Names

On the left side of the dialog is a list of tools and commands in Chief Architect that have a programmable hotkey.

- Filter the list by typing in the **Show Commands/Hotkeys Containing** text field.
- Click on a line item to select it.

### 3 Button Assignments

On the right side of the dialog is a list of typical gamepad buttons and the commands in Chief Architect that they are

mapped to.

- Click on a line item in this list to select it.
- Click the **Assign Selected Hotkey to Selected Button** button above the list of assignments to assign the command selected on the left to that gamepad button.

#### 4 Reset Commands

Click this button to restore the default commands associated with each gamepad button.

### THUMBSTICKS PANEL

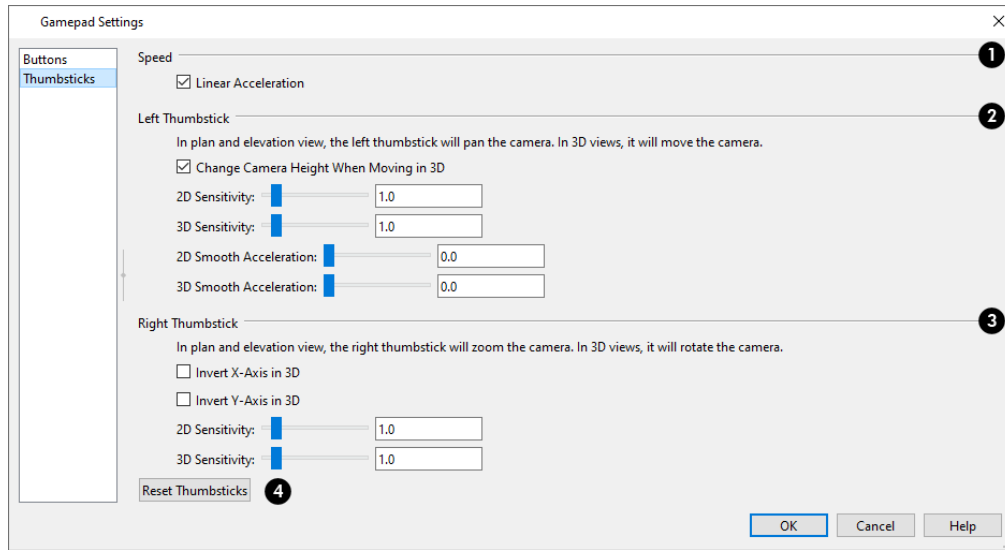

#### 1 Speed

When **Linear Acceleration** is checked, camera acceleration is always directly proportional to the amount the thumbstick is pushed. When unchecked, acceleration is increased on a curve, allowing more precision on the low end, and more speed on the high end.

#### 2 Left Thumbstick

- When **Change Camera Height When Moving in 3D**, the left thumbstick can be used to change the camera height in 3D. Uncheck this to maintain a consistent camera height instead.
- Use the slider bar or text field to specify the **2D Sensitivity**, which controls how quickly the view pans in plan and elevation views.
- Use the slider bar or text field to specify the **3D Sensitivity**, which controls how quickly the camera moves in 3D views.
- Use the slider bar or text field to specify the **2D Smooth Acceleration**, which controls how the speed at which acceleration and deceleration occur in 2D views.
- Use the slider bar or text field to specify the **3D Smooth Acceleration**, which controls the speed at which acceleration and deceleration occur in 3D views.

### 3 Right Thumbstick

- When **Invert X-Axis in 3D** is unchecked, pushing the right thumbstick to the left rotates the camera to the left. When checked, pushing this thumbstick to the left rotates the camera to the right.
- When **Invert Y-Axis in 3D** is unchecked, pushing the right thumbstick to the up rotates the camera upward. When checked, pushing the thumbstick up rotates the camera downward.
- Use the slider bar or text field to specify the **2D Sensitivity**, which controls how quickly the view zooms in plan and elevation views.
- Use the slider bar or text field to specify the **3D Sensitivity**, which controls how quickly the camera rotates in 3D views.

### 4 Reset Thumbsticks

Click this button to restore the default Left and Right Thumbsticks settings on this panel.

# Window and View Tools

## Chapter 6

The View and Window Tools let you control how views of your drawing are shown on screen, as well as toggle useful drawing aides on and off.

By default, Premier uses a tabbed document interface. The name of the file and the type of view displays at the top of each view window in its title bar. If the view is saved, its name also displays.

### TOPICS

<b>View Windows</b> .....	<b>144</b>
<b>Plan Views</b> .....	<b>146</b>
<b>Plan View Specification Dialog</b> .....	<b>148</b>
<b>Working in Multiple Views</b> .....	<b>150</b>
<b>View Tools</b> .....	<b>152</b>
<b>Zoom Tools</b> .....	<b>153</b>
<b>Fill Window</b> .....	<b>154</b>
<b>Panning the Display</b> .....	<b>154</b>
<b>Closing Views and Files</b> .....	<b>155</b>

## View Windows

In Chief Architect Premier, there are several different types of views:

- *Plan Views, see page 146*
- *3D Views, see page 1079*
- *Cross Section/Elevation Views, see page 1085*
- *Materials Lists, see page 1303*
- *CAD Details, see page 337*
- *Layout, see page 1333*

Each view displays in a view window. While multiple views can be open and display on screen, only one view window can be active at any given time. See *Working in Multiple Views on page 150*.

- Plan, 3D, and cross section/elevation views are found in plan files only. Each view window can show the model from a different perspective and display a unique set of information about it, making them useful for a variety of drawing tasks and print requirements.
- Materials Lists are found in plan files only and contain a list of objects found in the model along with their components and information like floor level and counts.
- CAD Details can be found in plan files only and contain 2D objects like CAD and Text.
- Layout files are composed of multiple pages. A given layout view window can only display a single page at a time.

### COORDINATE SYSTEM INDICATORS

In Chief Architect, the drawing area is laid out on a Cartesian grid, a three dimensional coordinate system described using the X, Y, and Z axes. As a reference, you can display one or more Coordinate and Origin Indicators in your views to help locate your model within this system. This can be particularly helpful in camera views or if you have rotated your drawing.

There are three types of Coordinate System Indicator:



The **Floating Axes Indicator** is always present at the lower left corner of a view window, regardless of the drawing space coordinates currently showing in the view. The length of the floating axes can be specified.



The **Fixed Axes Indicator** is always present at the drawing space Origin: 0,0,0 (0,0 in plan views, CAD Details, and layout) and may or may not be visible in the current view, depending on its extents. When visible, the fixed axes extend to the edges of the view window.



The **Origin Indicator** crosshairs are always present at the drawing space Origin. They are of a fixed size and may or may not be visible in the current view.

These Coordinate System Indicators can be turned on or off for different view types in the Preferences dialog. They can also be toggled on or off using the **View** menu, as well as using the toggle buttons that can be added to the toolbars. See *Coordinate System Panel on page 117*.

The Coordinate System Indicators are an on-screen reference only: they are not included when a view is printed, exported, or sent to layout.

### SAVED VIEWS

Most new views in plan files are temporary: if you close the view window, the view will not be retained. Two exceptions to this rule are CAD Details and Auto Elevations, which are saved automatically when they are created. See *CAD Details on page 337*.



If you add view-specific information to a view: for example, by adding text to a cross section/elevation view, you will be prompted to save the view.

## ACTIVE VIEW TOOLS



When a plan file is active, select **Tools> Active View** for tools that allow you to manage the current view. Not available when a layout file is active.



You can specify that any view be saved by selecting **Tools> Active View> Save Active View**. If the current view is unsaved, you will be prompted to give it a name. If it was previously saved, its saved attributes will be updated. If the active view is currently using all of its saved attributes, this tool will not be active.



You can also use **Tools> Active View> Save Active View As** to create an exact copy of the currently active view. Regardless of whether the current view is saved or not, you will be prompted to give the new view a name.

You can specify that any plan, camera, cross section/elevation view, or Materials List be saved. See [Plan Views on page 146](#) and [Saving 3D Views on page 1115](#).

When a view is saved, all of its attributes are retained, including the:

- Floor level
- Extents of the view
- Color toggle
- Active Layer Set
- Active Saved Defaults
- Watermark

If any of these attributes are changed, the changes will not be retained when you close the view unless the view is first re-saved.

Some additional settings are also view specific, although they do not require that a view be re-saved when they are changed:

- Saved Defaults or active Default Set
- Print Preview toggle
- Drawing Sheet Setup dialog settings

Saved views are listed in and can be managed the Project Browser. See [Project Browser on page 58](#).

## COORDINATE SYSTEM INDICATORS

In Chief Architect, the drawing area is laid out on a Cartesian grid: a three dimensional coordinate system described using the X, Y, and Z axes. Indicators for these axes as well as the drawing space origin at (0,0,0) can be set to display in a variety of view types to help you visualize your drawing's position and orientation in the coordinate system.

There are three types of Coordinate System Indicator:



The **Floating Axes Indicator** is always present at the lower left corner of a view window, regardless of the drawing space coordinates currently showing in the view. The length of the floating axes can be specified.



The **Fixed Axes Indicator** is always present at the drawing space Origin: 0,0,0 (0,0 in plan views, CAD Details, and layout) and may or may not be visible in the current view, depending on its extents. When visible, the fixed axes extend to the edges of the view window.



The **Origin Indicator** crosshairs are always present at the drawing space Origin. They are of a fixed size and may or may not be visible in the current view.

You can specify which indicator(s) display in several different view types as well as control aspects of the indicators' appearance in the Preferences dialog. See [Coordinate System Panel on page 117](#).

## VIEW SPECIFICATION DIALOGS

Each saved view has a specification dialog that can be opened by right-clicking on it in the Project Browser or by selecting **Tools> Active View> Edit Active View** while that view is active:

- [Plan View Specification Dialog, see page 148](#)
- [Camera Specification Dialogs, see page 1116](#)
- [Cross Section/Elevation Specification Dialogs, see page 1124](#)
- [Materials List Specification Dialog, see page 1312](#)
- [CAD Detail Specification Dialog, see page 338](#)

## CLOSING VIEW WINDOWS

There are a number of ways to close view windows. See [Closing Views and Files on page 155](#).

---

# Plan Views

Plan view is where most drawing and editing is done, and when you open a new plan file, a plan view is active. When an existing plan file is opened, the most recently used saved plan view will be active. If there are no saved views in a given plan, or if an unsaved plan view was last active, an unsaved plan view will open instead.



## NEW PLAN VIEW





To create a new plan view, select **Tools> New Plan View**. An identical copy of the current plan view is created and will become the active view. You can also right-click on the Plan Views folder in the Project Browser and select **New Saved Plan View** from the contextual menu.

Note: A new Saved Plan View can be created by selecting a plan view sent to layout and clicking the Create Saved Plan View edit tool. See [Saved and Unsaved Plan Views on page 1342](#).

There are three ways to save a plan view:

- Select **Tools> Active View> Save Active View**  to save the current view.
- Select **Tools> Active View> Save Active View As**  to create a copy of the current view.
- In the Project Browser, right-click on a view that is currently open and select **Save View** from the contextual menu.

There are three ways to open a saved plan view:

- Select a view from the **Saved Plan View Control**  **Plan View**  drop-down in the toolbars.
- Right-click on a view in the Plan Views folder in the Project Browser and select **Open View** from the contextual menu. See [Project Browser on page 58](#).
- If a saved plan view has been sent to layout, select its layout box and click the **Open View**  edit button. See [Editing Layout Views on page 1335](#).

## ROTATE PLAN VIEW

 To rotate everything in a plan view, including all objects on all floors, the Snap and Reference Grids, the plan's Cartesian coordinates, and the drawing sheet, select **Tools> Rotate Plan View** to open the Rotate Plan View dialog. See *3D Drafting on page 13*.

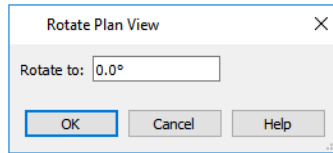





Enter the degrees to rotate the plan view to using decimal units with either positive or negative values. The degrees rotated displays in  $\pm 180^\circ$  format. For example, if you enter  $270^\circ$ , it displays as  $-90^\circ$  when the dialog is reopened.

**Rotate Plan View**  rotates a plan relative to its original orientation. For example, entering  $90^\circ$  twice results in a rotation of  $90^\circ$ , not  $180^\circ$ .

Text objects rotate with the plan unless you uncheck **Rotate with Plan** in the Text Specification dialog for each object. See *Rich Text Specification Dialog on page 500*.

Rotate Plan View only affects the currently active plan view. If you would like the current plan view to retain its rotation the next time it is opened, check **Remember Zoom/Rotation** in its specification dialog. See *Plan View Specification Dialog on page 148*.

If you use **Rotate Plan View**  and then use either the **CAD Detail from View**  or **Plan Footprint**  tool, the CAD Detail window that is created will permanently inherit the same rotation as the plan view. If you later modify the plan view's rotation, the CAD Detail will not be affected. See *CAD Details on page 337* and *Plan Footprint on page 339*.

 The Rotate Plan View tool does not rotate objects; it literally rotates only your view of those objects. As a result, it does not alter the orientation of the plan in layout views or on the printed page.

## REVERSE PLAN

 The **Reverse Plan** tool is a quick way to mirror a plan so that everything on all floors of the entire plan is swapped left to right.

Select **Tools> Reverse Plan** to reflect an entire plan right to left, as though it were flipped about a vertical line.

Reversing a plan rebuilds the entire model and affects views sent to layout.

## IMPORTING SAVED PLAN VIEWS

 To copy saved plan views from one plan file and import them into the current plan, select **File> Import> Import Saved Plan Views**.

Most attributes of a saved plan view are, potentially, imported. The Active Defaults, Layer Sets including Reference Display Sets, and the Current CAD Layer will all be imported provided that items of the same name do not already exist in the destination plan. If items of the same name do exist, they will be assigned to the imported saved plan view instead.

Two attributes are not imported: the Zoom/Rotation of the original view, and the Default Set. Even when the Active Defaults are imported into the destination plan, the imported saved plan view will be set to "Using Active Defaults." Default Sets can be imported separately if you wish. See *Exporting and Importing Default Sets on page 86*.

### To import saved plan views

1. Open the plan that you would like to import saved plan views into.
2. Select **File> Import> Import Saved Plan Views** .
3. In the Open Plan File dialog, browse to and select the plan file that you would like to import views from and click **OK**. See *Importing Files on page 45*.
4. In the Import Saved Plan Views dialog:

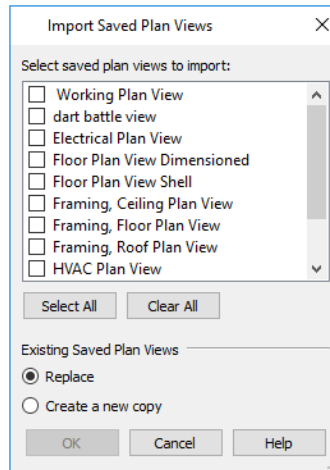

- Check the box beside all defaults that you would like to import.
- If the list of views is sufficiently long, a scrollbar will display on the right side of the list.
- Multiple line items can be selected by Shift+ or Ctrl+clicking their names. Then check or uncheck the box beside any selected item to affect the entire selection set. See *Shift and Ctrl Select on page 214*.
- Click the **Select All** button to place checks in the boxes beside all views in the list, or click **Clear All** to clear all of the check boxes.
- Select how to handle **Existing Saved Plan Views** in the current plan with the same name as those being imported. When **Replace** is chosen, the attributes of the saved plan view will be replaced, but not those of its Active Defaults, Layer Sets or Current CAD Layer.
- Click **OK** to close the dialog and import the selected saved plan views.

---

## Plan View Specification Dialog

To open the Plan View Specification dialog for any saved plan view, right-click on its name in the Project Browser and select **Edit View** from the contextual menu. See *Project Browser on page 58*.



You can also open this dialog for the currently active view by selecting **Tools> Active View> Edit Active View**.

## GENERAL PANEL

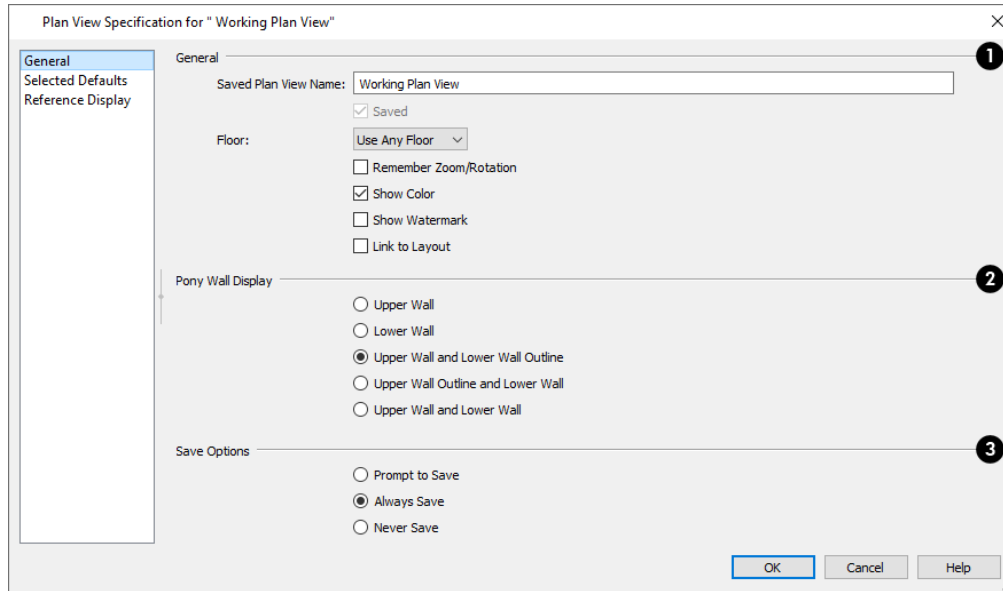

### 1 General

- Specify the **Name** of the saved plan view. This setting is not available if the view is unsaved.
- When an unsaved plan view is active, you can check **Saved** to make it saved. Once a view is saved, this box is shown for reference only and cannot be unchecked.
- Select the **Floor** level that the selected Plan View displays when it is opened. When “Use Any Floor” is selected, the view will return to whatever floor was active in it when the file was last saved.
- Check **Remember Zoom/Rotation** to maintain the extents of the view as well as its rotation the next time the view is opened. Not available for unsaved views. See *Zoom Tools on page 153* and *Rotate Plan View on page 147*.
- Uncheck **Show Color** to turn color off in the selected view. See *Color On/Off on page 191*.
- Check **Show Watermark** to display the watermark specified for the current plan file in the selected view. See *Watermarks on page 1377*.
- When **Link to Layout** is checked and the view is sent to layout, the layout view will be linked to the plan view. When this is unchecked, the layout view will use the current settings but will not be linked to the view. Not available for unsaved views. See *Saved and Unsaved Plan Views on page 1342*.

### 2 Pony Wall Display

These options control which part(s) of pony walls display by default in the current view. They are also found in the Pony Wall Defaults dialog. See *Displaying Pony Walls on page 354*.

### 3 Save Options

These settings control how or whether changes to the current view’s attributes are saved when those changes are made outside this dialog. Not available for unsaved views. See *Saved Views on page 144*.

- When **Prompt to Save** is selected, the program will ask whether you want to save any unsaved changes to the view when you close it.

- When **Always Save** is selected, any changes that you make to the view's attributes are saved automatically.
- When **Never Save** is selected, any changes that you make to the view's attributes are discarded when the view is closed.

### SELECTED DEFAULTS PANEL

The settings on the SELECTED DEFAULTS panel control which Saved Defaults and layer settings are used in the view. These settings are also found in the Active Defaults dialog. See *Active Defaults Dialog on page 82*.

### REFERENCE DISPLAY PANEL

The settings on the REFERENCE DISPLAY panel control the appearance of the Reference Display in the view. These settings are also found in the Change Floor/Reference dialog. See *The Reference Display on page 738*.

---

## Working in Multiple Views

There is no limit to the number of plan or layout files that can be open, nor is there a limit to the number of view windows that can be open. The name of the file and the type of view is stated at the top of each view window in its title bar as well as in its tab. If the view is saved, its name displays instead of the view type.

By default, Premier uses a tabbed document interface, which means that when more than one view window is open in the program window, each open window will have a tab that displays in a row above the currently active view.

- Each tab states the name of the file, the view type, and the view's name. Wall Detail tabs also state the floor that the associated wall is found on.
- Each tab features an icon indicating its type of view. These icons are also used in the Project Browser. See *Project Browser on page 58*.
- Click on a tab to make it the active view.
- If there is not enough room in the program window to display all tabs, left and right arrow buttons allow you to scroll through the tabs.
- Tabs can be reordered by clicking and dragging.

There is no limit to the number of 3D view windows that you can have open at a given time; bear in mind, though, that each window demands use of your computer's resources and that you may see poor performance if too many views are open. See *3D Views on page 1079*.

There are several ways to close a view window. See *Closing Views and Files on page 155*.

### TILING VIEWS



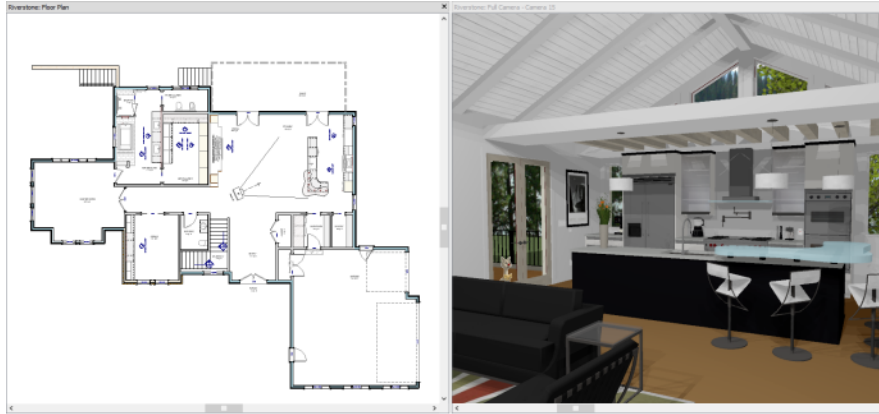

As an alternative to tabbed views, windows can instead be tiled. Tiling allows you to display multiple views in a single Premier window so you can see the results of changes in plan view in 3D or vice versa. It can also be useful for copying objects from one plan to another.



A plan view and camera view Tiled Vertically

There are several ways to create tiled views:

- Click and drag a view window's title bar or tab into the part of the drawing area that you would like it to be. When a highlighted space is created, release the mouse button.
- Select **Window> Tile Horizontally**  to display views in a horizontal orientation, one above the other.
- Select **Window> Tile Vertically**  or press Shift + F6 on the keyboard to display views in a vertical, side by side, orientation.

Views are tiled left to right or top to bottom in the order in which they were last active: the most recent view is on the left or at the top, while least recent is on the right or on the bottom.





- To activate a view, click on its title bar or anywhere in the view window. Note that any changes you make in the active window are reflected in other views as well.
- To end window tiling, select **Window> Tab Windows**. You can also end tiling by double-clicking on the title bar of the program window.

## MULTIPLE PROGRAM WINDOWS

To create a second program window, click and drag the title bar or tab of a view window completely out of the current program window: for example, onto a second monitor. A second Premier program window will be created with its own menu and toolbars.

## SWAPPING VIEWS

There are a number of ways to switch between open view windows:

- Click on a view window's tab.
- Select **Window> Swap Views**  or press F7 to switch between the two most recent views.
- The **Swap Views**  button toggles between the current view and the view that was current before it.
- Select **Window> Select Next Tab**  or **Window> Select Previous Tab**  to cycle through all open views in the order you prefer.
- In Windows, press the Ctrl + Tab (Next Window) or Ctrl + Shift + Tab (Previous Window) keys to cycle through all open views.
- On a Mac, press the Ctrl + } (Next Window) or Ctrl + Shift + { (Previous Window) keys to cycle through all open views.

- A list of all the views currently open is located at the bottom of the Window menu. Each view is identified by its name and what type of view it is. A check mark is beside the view that is currently active. Select one to go directly to that view.

If more than eight view windows are open, **More Windows** will be the last item in the Window menu. Select this option to open the Select Window dialog:

Select the name of a view in the list and click **OK** to make it the active view.

Note: The Window Menu Tools parent button can be added to the toolbars. See [Toolbar Customization Dialog on page 134](#).

## View Tools

The **View Tools** allow you to open and close the program's side windows, as well as toggle a variety of references and drawing aides. Select the **View** menu to access these tools. You can also add the **View Tools** parent button or any of its child tools to your toolbars. See [Adding and Removing Buttons on page 132](#).



**Refresh Display** redraws the current window to clean up extra lines, show missing items, and correct random on-screen effects caused by changes to the model. See [Refresh Display on page 191](#).



**Library Browser** opens and closes the Library Browser side window. See [The Library on page 945](#).



**Project Browser** opens and closes the Project Browser side window. See [Project Browser on page 58](#).



**Tool Palette** opens and closes the Tool Palette, which will display related tools. See [Child Tool Palette on page 129](#).



**Active Layer Display Options** opens and closes the side window of the same name. See [Drawing Groups on page 190](#).



**Status Bar** displays or suppresses the Status Bar at the bottom of the program window. See [The Status Bar on page 24](#).



**Scrollbars** displays and suppresses scrollbars on view windows. See [View Windows on page 17](#).



**Toolbars** displays and hides the program's toolbars. See [Toolbars and Hotkeys on page 128](#).



**Color** toggles the display of color in the current view. See [Color On/Off on page 191](#).



**Crosshairs** toggles the use of the blue crosshairs centered on the mouse pointer in most views.



**Coordinate System Indicator - Floating** toggles the Floating Axes Indicator in views of the current type in all files. See [Coordinate System Indicators on page 145](#).



**Coordinate System Indicator - Fixed** toggles the Fixed Axes Indicator in views of the current type in all files and can be added to the toolbars.



**Coordinate System Indicator - Origin** toggles the Origin Indicator in views of the current type in all files and can be added to the toolbars.







**Reference Grid** toggles the display of the Reference Grid in all views in the current plan or layout file. See [Grid Snaps on page 163](#).



**Angle Snap Grid** toggles the display of the Angle Snap Grid in all views in the current plan or layout file. See [Angle Snap Grid on page 163](#).



-  **Temporary Dimensions** toggles the use of Temporary Dimensions when objects are selected. See [Temporary Dimensions on page 473](#).
-  **Arc Centers and Ends** toggles the display of Arc Centers and Ends in the current view. See [Arc Centers and Ends on page 223](#).
-  **Line Weights** toggles the display of Line Weights in all views in which lines are drawn. See [Line Weights on page 1371](#).
-  **Drawing Sheet** toggles the display of the drawing sheet. See [Print Preview on page 1371](#).
-  **Watermarks** toggles the display of the current plan or layout file's watermark. See [Watermarks on page 1377](#).







## Zoom Tools

 **Zoom** is used to magnify any given area on the plan or 3D view. Select **Window > Zoom**, then click and drag a marquee around an area on screen. When you release the mouse, the selected area expands to fill the screen.

Note that in 3D views, using **Zoom** does not reposition the camera. This can lead to inconsistencies between a camera's position and what is actually shown in the view if other methods of zooming are used later. See [Navigating in Camera Views on page 1100](#).

When the zoom is complete, whatever tool was active prior to selecting the **Zoom** tool automatically becomes active again. If another zoom is needed, click the **Zoom** tool again.

These additional commands are also found in the **Window** menu:

-  **Zoom In** - Click to zoom in towards the screen center by a factor of two.
-  **Zoom Out** - Click to zoom out from the screen center by a factor of two.
-  **Undo Zoom** - Reverse the last zoom or fill window operation. This option is also found in the contextual menu, as is the **Zoom** tool. See [Menus, Toolbars, and Hotkeys on page 18](#).
-  **Fill Window Selected Objects** - Fits all selected items on screen.
-  **Fill Window Building Only** - Fits all walls and railings on the current floor on screen.
-  **Fill Window** - Fits all visible items on screen. See [Fill Window on page 154](#).

Note: Undo and Redo do not affect zoom.

### ZOOMING WITH THE MOUSE WHEEL

 Use the mouse wheel to zoom in and out in all view windows. Scrolling the mouse wheel one click up or down zooms in or out, centering on the location of your pointer and changing the zoom by about 10%.

By default, zooming in 3D views changes the camera's position. See [Mouse Scroll Wheel and Trackpad on page 1100](#).

Note: Depending on the configuration of your mouse, it may be necessary to hold down the Ctrl key while turning the mouse wheel.

---

## Fill Window



In plan view, a CAD Detail or a cross section/elevation view, select **Window> Fill Window** or press the **F6** key to view nearly everything on screen that is visible, including the Reference Display. CAD Points are the only objects that are not included when Fill Window is used.

If you are zoomed in so that only a portion of the drawing displays on screen, selecting **Fill Window** zooms out so that the entire view fits on the screen. If you are zoomed out so that the entire drawing is smaller than the screen, selecting **Fill Window** zooms in until the drawing fills the screen.

When the drawing sheet is shown, **Fill Window** zooms to the sheet borders.

### FILL WINDOW SELECTED OBJECTS



**Window> Fill Window Selected Objects** is similar to Fill Window, but zooms in or out so that the current selected object or objects fill the current window. See [Selecting Multiple Objects on page 213](#).

### FILL WINDOW BUILDING ONLY



**Window> Fill Window Building Only** is similar to **Fill Window**, but zooms in or out so that all walls, railings, and roof planes in the view fill the current window. These objects are included in the extents of the view even if their layers are turned off. Other objects are ignored.

### IN 3D VIEWS

The **Fill Window** tools behave slightly differently in perspective and orthographic 3D views. In perspective views, the original zoom factor is restored, while in orthographic views the camera's Field of View is adjusted so that all surfaces in the 3D view are included.

---

## Panning the Display

There are a number of ways to pan the display without changing the zoom factor.

### USING THE ARROW KEYS

In plan view, the Shift + arrow keys on the keyboard work exactly like clicking the arrow buttons on the scrollbar. They shift the display according to the number of inches defined in the Plan Defaults dialog.

### USING THE MOUSE

If you have a wheel mouse, you can pan the display by pressing the middle mouse button, or wheel, and moving the mouse in the direction you would like to pan. When the middle mouse button is held down, the pointer changes to a hand  icon.

In the Mac version of Chief Architect, you can pan using the left mouse button and Option key.

Mouse drivers sometimes have other functions assigned to the wheel and buttons. These override the Chief Architect setting.

The **Scale Layout Box Contents to Fit**  edit tool also allows you to pan within a layout box. See [Editing Layout Views on page 1345](#).

## USING A MAC TRACKPAD

In the Mac version of Chief Architect, you can two finger drag to pan the display. See [Trackpads on page 15](#).

## USING THE PAN WINDOW TOOL



The **Pan Window** tool works much like the mouse wheel method.

- Select **Window > Pan Window**. The pointer changes to a hand icon. Click and drag to pan the window. The program reverts to the previously active tool when you release the mouse button.
- Double-click the **Pan Window** tool and the command remains active.

## USING THE SCROLLBARS

One method is to use the scrollbars on the right and bottom edges of the window. See [View Windows on page 17](#).



- Click the end arrow keys on the scrollbars to shift the display in 12" increments.
- The 12" increment is defined in the Plan Defaults dialog under **Inches Scrolled by Arrow Key**. See [General Plan Defaults Dialog on page 92](#).

---

# Closing Views and Files

If a view is still needed, you can swap to a different view without closing it. If, however, a view is no longer needed, it can be closed. There are several ways to close a view window:

- Select **File > Close View** to close the active window.
- Press **Ctrl + W** or **Ctrl + F4** on the keyboard to close the active window.
- Click the **Close** button in the active view's title bar or in any view's tab.
- A tabbed view can be closed by clicking on its tab using the middle mouse button.
- Right-click on a Camera, Cross Section, or Plan View in the Project Browser and select **Close View** from the contextual menu.
- Select **File > Close All 3D Views**  to close all currently open camera view windows instead of just the active window.
- Select **File > Close All Views** to close all currently open view windows instead of just the active window.

If a plan has only one view window open and you try to close it, the program will prompt you to save before closing if there are any unsaved changes. Edited cross section/elevation and saved plan views also prompt you to save before closing. See [Saving Plan and Layout Files on page 40](#) and [Saved Views on page 144](#).



Although the program warns you if you try to exit without saving, you should get in the habit of saving plan files before exiting.

Even if all view windows are closed, the program can still be open. See *Exiting Chief Architect on page 56*.

# Creating Objects

## Chapter 7

There are a wide variety of objects in Chief Architect that you can use to create complete 3D models and working drawings. Although these objects are sometimes very different from one another, the methods used to create them are similar.

Once an object is created, it can be selected and edited to meet the requirements of your project. The editing characteristics common to most objects are described elsewhere. See *Editing Objects on page 205*.

### TOPICS

<b>Architectural vs CAD Objects</b> .....	<b>158</b>
<b>Defaults and Preferences</b> .....	<b>158</b>
<b>Snap Behaviors</b> .....	<b>159</b>
<b>Object Snaps</b> .....	<b>160</b>
<b>Angle Snaps</b> .....	<b>162</b>
<b>Grid Snaps</b> .....	<b>163</b>
<b>Creating Objects</b> .....	<b>164</b>
<b>Copying and Pasting Objects</b> .....	<b>167</b>

---

## Architectural vs CAD Objects

There are two broad categories of objects in Chief Architect: architectural objects and CAD objects.

CAD objects such as lines, arcs, text, and dimensions are 2D objects that can be created and edited in plan view, cross section/elevation views, CAD detail windows, and on layout pages but do not display in 3D camera views and overviews. See *The CAD Drawing Tools on page 295*.

In contrast, architectural objects such as walls, cabinets, doors, windows, and stairs display in 2D and 3D views. Architectural objects can be created and edited in 2D and 3D views but not in CAD Detail windows or on layout pages.

Some architectural objects, such as custom countertops and slabs, have some behaviors in common with CAD objects and are referred to as CAD-based.

---

## Defaults and Preferences

The ways that objects in the program behave as they are created and edited are affected by a number of default and preference settings. See *Preferences and Default Settings on page 76*.



It is a good idea to be familiar with these options and how they affect both drawing and editing in the program.

### SNAP SETTINGS

 Select **Edit> Snap Settings** to access the three categories of Snap Settings that determine how objects snap to one another and whether they snap to allowed angles or to points on a grid, as well as object bumping and pushing behaviors.

The available Snap Settings are:



**Object Snaps** - enables snapping to objects. See *Object Snaps on page 160*.



**Angle Snaps** - enables snapping at Allowed Angles. See *Angle Snaps on page 162*.



**Grid Snaps** - enables snapping to the Snap Grid. See *Grid Snaps on page 163*.



**Bumping/Pushing** - enables bumping and pushing behaviors. See *Bumping/Pushing on page 243*.

### EDIT BEHAVIORS

 Select **Edit> Edit Behaviors** to access the six global edit behavior modes that determine how dragging the edit handles with the left mouse button affects a selected object and may also affect how objects are drawn.

The available Edit Behaviors are:



**Default** - provides the most commonly used editing options. See *Default on page 206*.



**Alternate** - provides an alternative to the Default behaviors that may be more useful in some situations. See *Alternate on page 207*.



**Move** - allows you to move a selected object using the corner handles and the Move handle. See [Move on page 207](#).



**Resize** - scales an object as you drag a corner handle. See [Resize on page 208](#).



**Concentric** - allows you to resize objects so that the distance moved by each edge is the same as all other edges. See [Concentric on page 208](#).



**Fillet** - allows you to add a fillet at any corner of an object. See [Fillet on page 209](#).

## CONNECT CAD SEGMENTS



Select **Edit> Edit Behaviors> Connect CAD Segments** to toggle the ability to edit the individual segments of polyline-based objects and connected walls. See [Disconnect Edges on page 212](#).

Unlike Object Snaps, Connect CAD Segments also affects the ability to snap line- and arc-based objects together as they are drawn to form a polyline. See [Object Snaps on page 160](#).

## ROTATE/RESIZE ABOUT



Objects can be rotated or resized about either their own centers or the Current CAD point. See [Rotate/Resize About on page 259](#).

Specify which behavior is used by selecting **Edit> Edit Behaviors> Rotate/Resize About Current Point**  or in the Preferences dialog. See [Behaviors Panel on page 118](#).

## ARC CREATION MODES



Select **Edit> Arc Creation Modes** to access the five Arc Creation Modes that control how arcs and curved walls are drawn.

The available Arc Creation Modes are:



**Free Form Arc** - mode allows you to define an arc by clicking and dragging along the desired path. See [Free Form Arc on page 307](#).



**Center/Radius/End Arc** - mode allows you to define the center and radius of an arc, and then its length. See [Center/Radius/End Arc on page 308](#).



**Start/End/On Arc** - mode allows you to define the start and end points of an arc, then adjust the curvature. See [Start/End/On Arc on page 308](#).



**Start/Tangent/End Arc** - mode allows you to define the start and end points of an arc, its tangent and its curvature. See [Start/Tangent/End Arc on page 308](#).



**Arc About Center** - mode allows you to draw an arc by defining the center and then the start and end points. See [Arc About Center on page 309](#).

---

# Snap Behaviors

There are three categories of snap behavior in Chief Architect that affect how objects are created and how they can be edited:



**Object Snaps**, which snap CAD and architectural objects to other objects. See [Object Snaps on page 160](#).



**Angle Snaps**, which snap objects at specific angles. See *Angle Snaps on page 162*.



**Grid Snaps**, which snap objects to points on a grid. See *Grid Snaps on page 163*.

Snap behaviors can be controlled in the Preferences dialog and in the Plan or Layout Defaults dialogs. See *Snap Properties Panel on page 119* and *General Plan Defaults Dialog on page 92*.

You can select **Edit> Snap Settings**  to quickly turn Object, Angle and Grid Snaps on or off.

To temporarily disable Snap Behaviors and other move restrictions, press the Ctrl key while dragging an edit handle. See *Moving Objects on page 243*.

## HOTKEYS

You can also temporarily enable individual Snap Behaviors during a mouse editing operation using hotkeys. This can be helpful if you wish to use one particular type of snap behavior when you begin an operation, but a different behavior when you end it.

The Snap Behavior hotkeys are listed on the right side of the **Edit> Snap Settings**  submenu.

See *Hotkeys on page 137*.

### *To use snap behavior hotkeys*

1. Select **Edit> Snap Settings**  and toggle off the snap behavior category that you wish to control using hotkeys.
2. Select a tool that you wish to draw with or an object you wish to edit.
3. Begin drawing or editing and hold down the left mouse button without releasing.
4. Press and hold the appropriate key on your keyboard to enable the snap behavior associated with it.
5. When you are finished using the snap behavior, release the hotkey but continue holding down your left mouse button.
6. If you wish, you can press and hold a different hotkey on your keyboard and continue the drawing or editing operation.
7. When you are finished, release the left mouse button.

---

## Object Snaps



**Object Snaps** allow you to position objects precisely relative to each other; for example, to position lines so that their endpoints meet or roof plane edges so that they are collinear.

Object Snaps can be turned on or off by selecting **Edit> Snap Settings> Object Snaps** , by clicking the toggle button, or in the Preferences dialog. See *Snap Properties Panel on page 119*.

Object Snaps are indicated visually as you create or edit objects. To remove any object snap indicators that are visible on screen, press the 1 (one) key. As you continue drawing or editing, new indicators may appear.

With the exception of **On Object**  snaps, Object Snaps have priority over all other types of snapping in Chief Architect.

**Bumping/Pushing**  overrides Object Snaps, however. See *Bumping/Pushing on page 243*.



## OBJECT SNAP LOCATIONS

There are many locations on an object that other objects can snap to. In addition to snap points located on objects, Extension Snaps locate points away from objects. Each type of object snap can be toggled by selecting **Edit> Snap Settings**  or in the Preferences dialog. See *Snap Properties Panel on page 119*.

Regardless of which Object Snaps are active, when multiple objects are selected the selection set's only snap point is its midpoint.

## EXTENSION SNAPS

For some operations, it is helpful to snap to a point far away from an original object, while maintaining a relationship to a point on that object. For example, you may want to snap to a point exactly perpendicular to a line's endpoint. Extension Snaps are helpful in these situations.

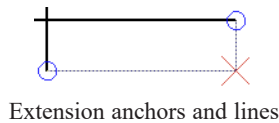



Extension anchors and lines

Extension Snaps are indicated by extension anchors, indicated by small blue circles.

Anchors display for Endpoint, Midpoint, and Quadrant snaps when these snap behaviors are enabled.

When an anchor is established, you can create **Tangent** , **Perpendicular**  and **Orthogonal**  extension lines relative to it.

### *To use extension snaps*

1. Toggle on **Object Snaps**  and make sure the extension snaps are enabled.
2. Draw a **Rectangular Polyline** .
3. Select the **Draw Line**  tool and move your pointer along the edges of the polyline.
4. When your pointer passes over an endpoint or midpoint, an extension anchor is created.
5. Move your pointer perpendicular edge displaying the anchor to create a blue, dashed extension line.

Only a limited number of anchors can exist at one time; creating a new anchor removes the oldest existing anchor. You can specify the number of possible anchors in the Preferences dialog. See *Snap Properties Panel on page 119*.

## WALL INTERSECTION EXTENSION SNAPS

As walls are drawn, extension lines identify points that are either collinear or orthogonal to the end points of other walls. These extension lines identify potential intersection points and display only when **Intersection Snaps**  are enabled. See *Creating Walls on page 357*.

## OBJECT SNAPS HOTKEYS

- Press the “1” key to clear out all current extension anchors.
- Hold down the “S” key to temporarily disable Object Snaps. You are still able to use Extension Snaps to existing anchors, so the “S” key can be used to avoid picking up unwanted extension anchors.

## THE “S” KEY - CASE STUDY

In the following example, there are several lines. Suppose we want to start a line at the intersection of two orthogonal extension lines drawn from two lines, **A** and **B**. To establish an extension anchor, we need to drag the mouse over line **A**'s endpoint, but there are several lines between the endpoints of lines **A** and **B**. We need to establish the two extension anchors without snapping to the intervening objects.

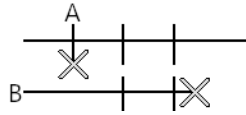

### *To establish two extension anchors*

1. Drag the mouse over the endpoint for line **A** to establish the first endpoint anchor.
2. Temporarily disable object snapping by holding down the “S” key.
3. Move the mouse to the end of line **B**.
4. Release the “S” key to establish the second endpoint anchor.
5. Move the mouse to the intersection of the two extension lines and draw the new object.

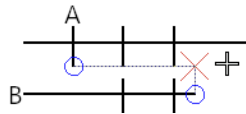

The S key can help establish Extension snaps when other objects may interfere

---

## Angle Snaps

It is often important that objects be drawn at exact angles. This can be accomplished using **Angle Snaps**. Angle Snaps allow you to draw walls, lines, and other objects at specified Allowed Angles. Angle Snaps also affect the way objects rotate, the radius of arcs, and a variety of other operations.

You can specify whether Angle Snaps use 15° increments or 7.5° increments plus any additional Allowed Angles that you may specify. See [General Plan Defaults Dialog on page 92](#).

Angle Snaps can be turned on or off by selecting **Edit> Snap Settings> Angle Snaps** , by clicking the toggle button, or in the Preferences dialog. See [Snap Properties Panel on page 119](#).

Because drawing at regular angles is extremely important, when Angle Snaps are disabled, the Angle Snaps  icon will display near and follow the pointer. See [Pointer Icons on page 16](#).

### ANGLE SNAP SETTINGS

You can change Allowed Angle settings for Angle Snaps in the Plan Defaults or Layout Defaults dialog. See [General Plan Defaults Dialog on page 92](#).

Specify **15 Degree** or **7 ½ Degree** angle snaps. You can also specify **Additional Angles**.

## ANGLE SNAPS AND OBJECT SNAPS

Angle Snaps have a higher priority than Grid Snaps and **On Object Snaps** , but a lower priority to all other Object Snaps. If a valid Object Snap exists, the program uses that instead of an Angle Snap.

 Walls are an exception to this snapping prioritization. When walls are drawn or edited, Angle Snaps take higher priority than Object Snaps. See [Creating Walls on page 357](#).

Sometimes both Angle Snaps and Object Snaps apply. For example, suppose a CAD line is drawn at 15° using Angle Snaps and another line is approached. You can draw the new line at 15° using **Intersection Snaps**  to snap to a point on the existing line.

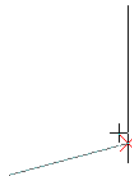

Use Object Snapping and Angle Snapping to draw a line at a 15° angle that intersects and existing line

Now suppose that we don't want the new line to end on the existing line. Hold down the “S” key to temporarily disable Object Snaps, allowing only Angle Snaps. See [The “S” Key - Case Study on page 162](#).

## ANGLE SNAP GRID

 The **Angle Snap Grid** is a visual reference aide that displays the Allowed Angles in the current plan when line-based objects are being drawn. Select **View> Angle Snap Grid** to toggle this feature on or off. The Angle Snap Grid can be also turned on and off in the Preferences dialog and is disabled by default. See [Snap Properties Panel on page 119](#).

When Grid Snaps are enabled, small perpendicular hatch lines display along the lengths of the Angle Snap Grid lines, indicating the Snap Grid Unit. See [Grid Snaps on page 163](#).

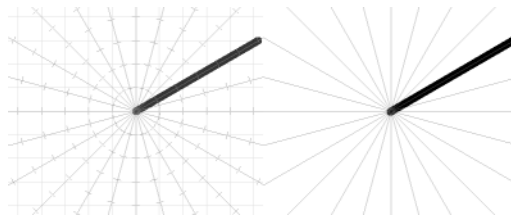

CAD Line drawn with Angle Snap Grid on, Grid Snaps on vs off

---

## Grid Snaps

 **Grid Snaps** allow you to snap objects to points on an on-screen grid as they are created, moved, and resized. See [Moving Objects on page 243](#) and [Resizing Objects on page 253](#).

It is recommended that you draw and position the exterior walls of your plan with **Grid Snaps** enabled. Once these walls are in place, you may choose to turn Grid Snaps off to finish the rest of the drawing.

Grid Snaps are turned on and off by selecting **Edit> Snap Settings> Grid Snaps**, by clicking the toggle button, or in the Plan or Layout Defaults dialog.

## REFERENCE GRID

 In addition to the Snap Grid, the **Reference Grid** is provided to give you a visual sense of scale. It is useful for zooming in and out, or for general layout guidelines, but is not used for snapping. The Reference Grid can be toggled on and off by selecting **View> Reference Grid**. See *View Tools on page 152*.

The appearance and size of the Snap and Reference Grids can be controlled in the Plan Defaults and Layout Defaults dialogs. See *General Plan Defaults Dialog on page 92*.

## GRID SNAPS AND ANGLE SNAPS

Of the three snap behaviors, Grid Snaps have the lowest priority and are overridden by Angle Snaps and Object Snaps.

When Grid snaps and Angle Snaps are both enabled, objects are drawn and edited using Polar Coordinates. For example, if the grid **Snap Unit** is set to 12" (1 foot), drawing a new wall at an Allowed Angle snaps the wall length to 0", 12", 24", and so on. The Angle Snap Grid illustrates this nicely: when Grid Snaps are enabled, small perpendicular hatch lines display along the lengths of the Angle Snap Grid lines. These hatches are at regular intervals equal to the Snap Grid Unit, but do not necessarily align with the Snap Grid itself. See *Angle Snap Grid on page 163*.

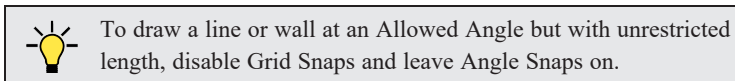

---

# Creating Objects

In Chief Architect Premier, there are five ways to add new objects to your drawing: by clicking to place an object, by clicking and dragging to draw an object, by entering coordinates, by placing a distribution path or region, or by importing custom symbols, CAD drawings, pictures or metafiles.

If you create an object using any of these methods and the layer it will go on is either locked or turned off, the program will ask you if you want to unlock or display the layer. Objects can be created on layers that are not set to display, but they cannot be created on locked layers. See *Object Creation and Layers on page 167*.

While the size of the drawing area in Chief Architect is limited only by the resources on your computer, it is best to begin your drawing near the origin, 0,0. The current position of your mouse pointer displays in the Status Bar at the bottom of the program window. See *3D Drafting on page 13*.

## CLICK-TO-CREATE



Many objects, including doors and windows, cabinets, library symbols, text, pictures, and images are created by clicking. Select a library object or one of the drawing tools mentioned above, then click in the drawing area to place the object at that location.

Continue clicking to place the selected object until another tool is selected.

If you click at a location where there is not enough room for the object to be placed, one of two things may happen:

- Some objects, notably cabinets, doors, and windows, will resize smaller to fit into the space.
- Most objects cannot resize in this manner, so the program will present a warning message indicating that there is not sufficient space at the current location.

When most drawing tools are active or library symbols selected for placement, a preview outline follows your mouse pointer, indicating the size and shape of the object to be created. If your pointer is positioned at a location where the object cannot be placed, this preview outline will not display.

As you move the mouse pointer, the center point of the object's back edge will snap to active snap points when **Grid Snaps**  or **Object Snaps**  are enabled. See *Snap Behaviors on page 159*.

Many architectural objects can be created in plan view or any 3D view. In order to place a stand-alone, click-to-create object in 3D, it is necessary to click near a wall or within the Terrain Perimeter as these objects help orient the new object within the 3D space.

## CLICKING AND DRAGGING

Other objects, including walls and railings, straight stairs, and CAD and CAD-based objects are created by clicking and dragging to define either a path or an enclosed area. Select a tool, then click and drag in the drawing area to draw an object between your start and end points.

Continue drawing the selected object until another tool is selected.

You can temporarily slow the movement of the mouse as you drag by holding down the Shift key on your keyboard.

You can cancel any click-and-drag drawing operation before it is completed by pressing the Esc key on your keyboard, or by pressing any two mouse buttons at the same time.

When the **Alternate**  edit behavior is active, a continuous drawing behavior is enabled, allowing you to click at the start and end points of line- and arc-based objects without dragging. See *Alternate on page 207*.

### ***To continuously draw by right-clicking***

1. Select a tool that creates line- or arc-based objects.
2. Right-click, drag, and release the mouse button to draw the first object.
3. Move the pointer to a different location and notice the drawing indicator that begins at the object's endpoint and follows your pointer as it moves.
4. Click to create a second object beginning at the first object's starting point and ending where you clicked.
5. Continue moving the pointer and clicking to create additional objects until:
  - Another tool is selected,
  - The Esc key is pressed,
  - Two mouse buttons are pressed at the same time,
  - The left mouse button is double-clicked,
  - A closed shape is formed.

 To keep the Alternate Drawing Mode enabled when a closed shape is formed, uncheck Stop When Connected in the Preferences dialog. See *Behaviors Panel on page 118*.

Polyline- and Spline-based objects can be created by snapping multiple Line-, Arc-, and/or Spline-based objects together. These objects will only snap together to form a polyline or spline if they are on the same layer and share identical attributes such as color, line style, and arrow specifications. See *Editing Objects on page 205*.

## ENTERING COORDINATES

Objects created by clicking and dragging can also be drawn by entering coordinates. See [3D Drafting on page 13](#).

Coordinates can be either absolute or relative. Absolute coordinates refer to a fixed point of origin at 0,0, while relative coordinates treat the current location of the selected object as the point of origin.

### *To use the Enter Coordinates dialog*

1. Select any tool that requires you to click and drag to create an object.
2. Click and begin dragging to draw the object.
3. Before you finish dragging and with the mouse button pressed, press either the Tab or Enter key on your keyboard.
4. In the Enter Coordinates dialog:

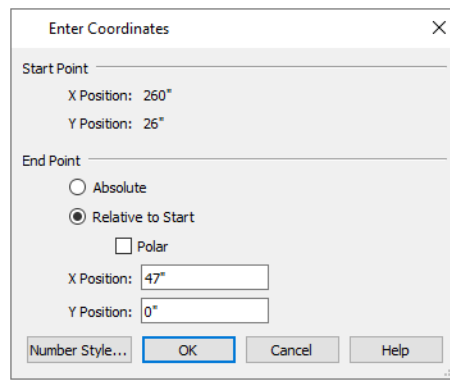

- The **Start Location**, where you clicked and began dragging, displays at the top.
5. Specify the method used to define the **New Location**, or end point.
    - Select **Absolute** to define the end point using absolute coordinates on the snap grid.
    - Select **Relative to Start** to define the end point relative to the start point, as though the start point was at (0,0).
    - Check **Polar** to define the end point of the new line by its **Distance** and **Angle** from the start point rather than as X and Y coordinates.
    - The program remembers which option you last used in this dialog.
  6. Specify the position of the end point, either as X and Y Position coordinates, or as Distance and Angle.
  7. Click OK to close the dialog and create the object.

CAD lines, arcs and points can also be created using the Input Line, Input Arc and Input Point dialogs. See [Input Point on page 296](#), [Input Line on page 301](#), or [Input Arc on page 309](#).

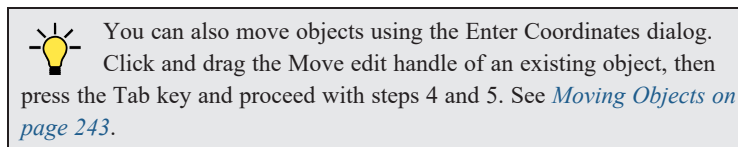

## AUTO REBUILD

A number of objects, notably foundations, roofs, and framing, can be automatically generated and rebuilt as changes are made to the model. Objects created in this manner can be edited just like other objects; however, the Auto Rebuild

functionality will be disabled.

## DISTRIBUTING OBJECTS

You can place multiple copies of any object in an evenly-spaced array either within a region or along a path using the **Distributed Objects**  tools. See *Distributed Objects on page 1042*.

## IMPORTING OBJECTS

Custom symbols, CAD drawings, pictures and metafiles can be imported into the program and placed in the drawing area with a click. See *Importing and Exporting on page 1222* and *Pictures, Images, and Walkthroughs on page 1184*.

## CONVERTING OBJECTS

A variety of objects can be created by converting existing CAD objects and many CAD-based objects into another type of object. See *Converting Objects on page 262*.

## OBJECT CREATION AND LAYERS

When it is created, every object is placed on a layer which controls whether and how it displays. See *Layers on page 176*.

If you try to create an object on a layer that is not set to display in the current view, the program will ask if you want to turn that layer on. See *Message Boxes on page 25*.

- Click **Yes** to create the object and turn on its layer in the current view.
- Click **No** to create the object but leave its layer turned off in the current view.
- Click **Cancel** to not create the object and leave the layer turned off.

If you try to create an object on a layer that is locked, the program will prompt you to unlock the layer. If you choose to leave the layer locked, the object will not be created. See *Locking Layers on page 178*.

Similarly, if you try to insert an object into another object that is on a locked layer, nothing will be created. See *Inserted Objects on page 973*.

If you place an object on a renamed or custom layer and then paste it into a new plan or layout file, a new layer will be created in the destination file. See *Copying and Pasting Objects on page 167*.

---

# Copying and Pasting Objects

New objects can also be created by cutting, copying, and pasting existing objects, either individually or in groups. Objects can be copied from one floor to another, one view window to another, and one file to another. Because copying uses your system's clipboard, some objects can be pasted into other applications, as well.

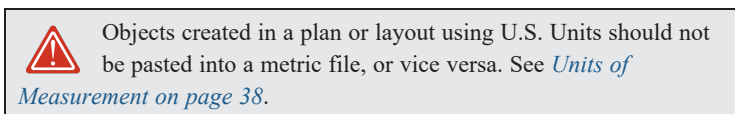

Objects cannot be pasted into any views that they cannot be created in normally. For example, CAD objects cannot be pasted into a 3D camera view or overview, while Architectural objects cannot be pasted onto a layout page or into a CAD Detail window.

If an object on a custom layer or one that inherits properties from a Saved Dimension Default or Saved Text Style is pasted into a different plan or layout file:

- That Saved Default, Text Style, or layer will be created in the destination file if it does not already exist.
- If a Saved Default, Text Style, or layer with the same name does exist in the destination file, the object will inherit its attributes from the existing settings.

See *Multiple Saved Defaults on page 79* and *Layers on page 176*.

Note: Terrain Perimeters can be copied and pasted, but the pasted copy will be a Standard Polyline which can then be converted into a Terrain Perimeter or other type of polyline. See *Convert Polyline on page 262*.

There are a number of ways that objects can be cut, copied, and pasted:

## CUT, COPY, AND PASTE

The Cut, Copy, and Paste tools allow you to copy a selection to the system clipboard and then paste it into a different view window, onto a different floor level, or even into a different application.



Select **Edit> Cut** or press **Ctrl + X** to remove the selected object(s) from the file and save them in the system clipboard so that the selection can be pasted in a different location in Chief Architect or in another application, depending on the type of selection.



Select **Edit> Copy** or press **Ctrl + C** to save a copy of the selected object(s) to the system clipboard while maintaining the original(s). The selection can then be pasted in a different location in Chief Architect or in another application, depending on the type of selection.



Select **Edit> Paste** or press **Ctrl + V** to enable Paste mode, then left- or right-click in the current view to paste the selected object(s) previously copied to the system clipboard at that location. If pasting from another application, click in the destination view in Chief Architect first to make sure it is active.

### *To Cut, Copy, and Paste*

1. Select an object or objects to copy, then:
  - Select **Edit> Cut** or press **Ctrl + X** to remove the original selection from the file and copy it to the system clipboard.
  - Select **Edit> Copy** or press **Ctrl + C** to copy the selection to the clipboard while retaining the original.
2. If you wish to paste the copy in a different view or program window, open that window and click in it to make it active.
3. Select **Edit> Paste** from the menu or press **Ctrl + V**.
4. When pasting in Chief Architect, the mouse pointer will display the Copy/Paste  icon. Left- or right-click once to paste a copy of the object at that location.

If the new object(s) are pasted into Chief Architect, they will be selected. Objects pasted in 3D views are selected on their top surfaces.

If the selection being pasted consists of text, it is placed in a Text object.

If the selection being pasted is an image, the Paste Image dialog opens.



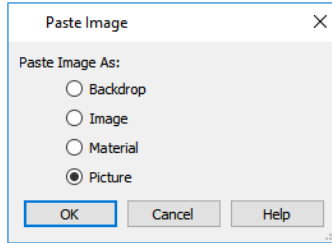



The options in the Paste Image dialog and their results are similar to those in the Screen Capture Setup dialog. See [Creating Screen Captures on page 1203](#).

## COPY/PASTE



 The **Copy/Paste** edit tool allows you to copy the selected object(s) to the system clipboard and immediately enable the Paste function so that a copy can be made in the current view. Edit handles and a variety of edit tools let you control the location, orientation, and size/shape of the pasted object(s).

### To Copy/Paste by clicking







1. Select an object or objects to copy.
2. Click the **Copy/Paste**  edit button. The cursor displays the Copy/Paste  icon.
3. Left- or right-click once to paste a copy of the selection at that point where you clicked.

The Copy/Paste edit tool can be used in combination with the original selection's edit handles to move, rotate, or reshape the copy relative to the original. The available edit handles will vary depending on the type and number of objects selected. See [Edit Handles on page 23](#).







### To Copy/Paste by dragging

1. Select an object or objects to copy.
2. Click the **Copy/Paste**  edit button. The cursor displays the Copy/Paste  icon.
3. Click and drag an edit handle:
  - Drag the Move edit handle to position the copy at a new location. As you drag, a preview of the selection follows the mouse pointer.
  - CAD lines and some line-based objects have a round Orthogonal Move edit handle. When dragged, movement is restricted to directions that are perpendicular to the selected line.
  - Other types of CAD and CAD-based objects have a round Concentric Resize edit handle. Click and drag this handle to create a concentric copy that is either larger or smaller than the original.
  - Drag a corner handle to create a copy in the same location as the original but with a different shape or size. The result depends on which **Edit Behavior**  you use. See [Defaults, Preferences, and Edit Behaviors on page 206](#).
  - Drag the Rotate handle to create a copy in the same location as the original, but rotated to a different angle.
4. You can resize or position the copy accurately with respect to the original by watching the moved distance in the Status Bar at the bottom of the screen.

The **Copy/Paste**  edit button activates Paste mode in which each available edit tool and handle makes a copy in addition to its primary function and seven new edit buttons display on the Edit Toolbar.



-  Click the **Sticky Mode** edit button to remain in the current mode and place multiple copies of the selected object (s). See *Sticky Mode on page 170*, below.
-  Click the **Paste Hold Position** edit button create a copy of the selection at the same location as the original. See *Paste Hold Position on page 171*, below.
-  Click the **Point to Point Move** edit button to make a copy of the selection at a specific location. See *Point to Point Move on page 245*.
-  Click the **Point to Point Center** edit button to make a copy of the selection centered between two points. See *Point to Point Center on page 251*.
-  Click the **Center Object** edit button to make a copy of the selection and center it relative to another object. See *Center Object on page 250*.
-  Click the **Reflect About Object** edit button to make a copy of the selection reflected about another object. See *Reflect About Object on page 261*.
-  Click the **Main Edit Mode** edit button or press the Esc key to return to the selection's main edit toolbar.

### To use Copy/Paste with other edit tools

1. Select the object(s) to be copied and click the **Copy/Paste**  edit button.
2. Notice that the options in the Edit Toolbar change and include several tools for moving and centering:
  - Click the **Point to Point Move**  edit button, then click at the start and end points to position the copy at a particular point. After your click on the start point, an extension line, selection preview outline, and Point B  icon follow the mouse pointer.
  - Click the **Point to Point Center**  edit button, then click on the two points that you would like to center the copy between.
  - Click the **Center Object**  edit button, then mouse over the object you want to center the copy relative to and click once when the desired centering axis and selection preview outline displays.
  - Click the **Reflect About Object**  edit button, then mouse over the object you want to reflect the copy about and click once when the desired reflection axis and selection preview outline displays.
3. An exact copy of the selected object(s) is created and is positioned and oriented based on the actions performed using the second edit tool.

### STICKY MODE

 Normally, after an action is performed using the edit tools or handles while in an edit mode such as Paste mode, you return to the Main Edit Mode. Click the **Sticky Mode** edit button to remain in Paste mode and continue pasting copies of the selected object(s).

To exit Paste mode and return to the main edit toolbar for the selected object, click the **Main Edit Mode**  edit button or press the Esc key on your keyboard. If you have not pasted a copy of the selected object and immediately click **Copy/Paste**  after returning to the Main Edit Mode, **Sticky Mode**  is still enabled.

 Sticky Mode is available when the Trim Object(s), Extend Object(s), Copy/Paste or Multiple Copy edit button is clicked. See *Trim and Extend on page 272*.

## PASTE HOLD POSITION





Click the **Paste Hold Position** edit button to create a copy of the selected object(s) at the same location as the original. The copy remains selected so you can perform additional operations.

Because multiple walls, railing and fencing cannot share the same space, the **Paste Hold Position**  edit button is not available for these objects.

When copying between different floors or view windows, you can paste a copy at the same absolute position as the original selection using the **Paste Hold Position** command.

### *To use Paste Hold Position*

1. Select the object(s) to be copied.
2. Click the **Copy/Paste**  edit button.
3. Switch to the desired floor or plan file and select **Edit> Paste> Paste Hold Position** .
4. A copy is placed at the same X, Y coordinates on the new floor or in the new plan as the original's position.



When a CAD-based object is moved to a new floor, only its display in plan view is moved - its physical location in the model remains unchanged. See [Architectural vs CAD Objects on page 158](#).

## COPY AND PASTE IN PLACE



Select **Edit> Copy and Paste in Place** to create a copy of the selected object(s) at the same location as the original. The copy remains selected so you can perform additional operations.

Because multiple walls, railings, and fencing cannot share the same space, the **Copy and Paste in Place** command is not available for these objects.

## PASTE SPECIAL



The **Paste Special** tool allows you to choose a representation for the selection to be pasted.

Selections can be pasted as:

- Enhanced Windows Metafiles (EMF). See [Metafiles on page 1195](#).
- Device Independent Bitmaps (BMP). See [Importing Pictures on page 1192](#).
- Unformatted non-unicode text (TXT).
- File Name (a path to a file). Depending on the file type, it will be either opened or imported (if supported).
- Unformatted text (HTML). Pastes as text.
- Model Objects - Chief Architect format, not compatible with other programs.

### *To use Paste Special*

1. Select an object, image, text or file on your computer and copy it.
2. Switch to the desired Chief Architect view window and select **Edit> Paste> Paste Special** .



3. In the Paste Special dialog, select the desired representation for the selection and click OK.
4. Click in the drawing area to place the copy at that location.

## MULTIPLE COPY

➔ The **Multiple Copy** edit button makes it easy to create regularly spaced or concentric copies of any object or group of objects, including CAD Blocks and Architectural Blocks.



The copy intervals, or offsets, between copies can be specified in the Multiple Copy dialog. See [Multiple Copy Dialog on page 173](#).

### To use Multiple Copy

1. Select the object(s) to copy.
2. Click the **Multiple Copy**  edit button.
3. Click the **Sticky Mode**  edit button if you wish to make more than one set of multiple copies.
4. Regardless of the object type selected, these two edit handles will display on the selected object:
  - Click and drag the square Move edit handle. Copies of the selection are made at regular intervals between the original and the pointer's location.
  - Click and drag the triangular Rotate edit handle. Rotated copies of the selection are made at regular intervals.





The Rotate handle can create an array about the selection's center or about a CAD point. See [Rotate/Resize About on page 159](#).

5. Some CAD-based objects have a third edit handle:
  - CAD lines and some line-based objects have a round Orthogonal Move edit handle. Click and drag this handle to create an array of copies that is perpendicular to the original selection.
  - Other types of CAD and CAD-based objects have a round Concentric Resize edit handle. Click and drag this handle to create concentric copies of the selection at regular intervals either within or surrounding the selection.
6. Release the mouse button to place the copies. The dragged distance determines the number of copies placed.
7. If you clicked the **Sticky Mode**  edit button, you can drag the last object created to make additional copies.
8. Click the **Main Edit Mode**  edit button or press the Esc key to return to the selected object's main edit toolbar.

The **Multiple Copy**  tool can be used with the **Alternate**  edit behavior to create arrayed copies of objects. See [Alternate on page 207](#).

### To create an array of copies



1. Select the object(s) to copy.
2. Click the **Multiple Copy**  edit button.
3. Right-click to enable the **Alternate**  edit behavior and drag the either Move or the Rotate edit handle in any direction. The **Primary Offset** or **Primary Number of Copies** is used.

4. Release the mouse button and move the pointer in another direction. The **Secondary Offset** or **Secondary Copies** value is used.
5. Click the left or right mouse button to place the array of copies.

## MULTIPLE COPY DIALOG

The Multiple Copy dialog lets you specify separate multiple copy intervals for:

- General objects
- Roof and floor trusses
- Rafters
- Floor and ceiling joists, posts, and beams
- Wall studs

To open this dialog, click the **Multiple Copy**  button and then click the **Multiple Copy Interval**  button.

Note: The settings in the Multiple Copy dialog are global rather than file-specific and are retained between program sessions.

### 1 Offset Between Copies When Dragging

Click the **Offset Between Copies When Dragging** radio button to specify the offsets, or copy intervals, at which objects are copied as you drag with the mouse.



- **Primary Offset** - Specify the offset, or copy interval, for each object type.
- You can also specify a **Secondary Offset** for each object type that is used when the **Alternate**  edit behavior is active. See [Alternate](#) on page 207.
- **Rotation Of All Objects** - Specify the copy interval, in degrees, to be used when objects are rotated as they are copied.

### 2 Evenly Distribute Copies When Dragging

Click this radio button to specify a set number of copies to be made as you drag with the mouse. The further you drag, the wider the spaces between the copies. These settings apply to all object types.

- **Primary Number of Copies** - Specify the number of copies to be made.
- **Secondary Copies** - Specify the number of copies to be made when the **Alternate**  edit behavior is active.

### TRANSFORM/REPLICATE OBJECT

-   Objects and groups of objects can be copied and pasted using the Transform Replicate Object dialog. See
  - *Transform/Replicate Object Dialog on page 266.*

# Displaying Objects

## Chapter 8

The way that objects display is an important in all stages of the design process. There are two primary ways that the display of objects is controlled: Drawing Groups and Layers.

### TOPICS

<b>Displaying Objects</b> .....	<b>176</b>
<b>Layers</b> .....	<b>176</b>
<b>Layer Attributes</b> .....	<b>177</b>
<b>Layer Display Options Dialog</b> .....	<b>179</b>
<b>Layer Sets</b> .....	<b>182</b>
<b>Layer Set Defaults</b> .....	<b>183</b>
<b>Layer Set Management</b> .....	<b>184</b>
<b>Active Layer Display Options</b> .....	<b>185</b>
<b>Select Layer Dialog</b> .....	<b>186</b>
<b>Layer Panel</b> .....	<b>186</b>
<b>Object Layer Properties</b> .....	<b>187</b>
<b>Layer Painter, Eyedropper, and Hider</b> .....	<b>188</b>
<b>Exporting and Importing Layer Sets</b> .....	<b>189</b>
<b>Drawing Groups</b> .....	<b>190</b>
<b>Display Toggles</b> .....	<b>191</b>
<b>Fill Styles</b> .....	<b>192</b>
<b>Fill Style Panel and Dialogs</b> .....	<b>193</b>
<b>Custom Patterns</b> .....	<b>196</b>
<b>Line Styles</b> .....	<b>199</b>
<b>Line Style Specification Dialog</b> .....	<b>201</b>
<b>Color Chooser/Select Color Dialog</b> .....	<b>203</b>

---

## Displaying Objects

There are two broad categories of objects in Chief Architect: architectural objects and CAD objects. See *Architectural vs CAD Objects on page 158*.

CAD objects are two-dimensional and display only in the view in which they were drawn. Architectural objects, on the other hand, are 3D and are represented in 2D and 3D views in different ways.

### LAYER SETTINGS

By default, CAD and CAD-based objects use the settings assigned to their layer: including line style, color, and weight. They can be assigned custom line attributes in their specification dialogs. See *Line and Text Styles on page 178*.

In plan view, architectural objects are represented much like CAD objects, using the attributes assigned to their layer. In addition, the edge lines of architectural objects in Vector Views also use these layer settings. See *Vector View on page 1150*.

In addition, layers can be used to turn the display of objects on and off in different views. See *Layer Attributes on page 177*.

### FILL STYLES

Closed CAD objects can also be assigned a fill style for their interior areas. Fill styles may be a solid color or a pattern, and can be specified as transparent. See *Fill Styles on page 192*.

Many architectural objects can also be assigned a fill style; however, it is only used in plan view. In 3D views, architectural objects are represented using surfaces that have materials assigned to them.

### PATTERNS AND TEXTURES

The appearance of architectural objects in 3D views is determined by the materials applied to the objects' surfaces. See *Materials on page 1049*.

Material patterns display in Technical Illustration, Hand Drawn Lines, and Vector Views, while textures display in other types of rendered views. See *Rendering Techniques on page 1150*.

You can turn the display of patterns on or off in 3D views that use them by selecting **3D> Toggle Patterns** .

---

## Layers

Layers are used to organize and manage the display of all objects in all views and in the Materials List. A layer can be thought of as a transparency sheet with objects placed on it for viewing. Nearly all views use multiple layers, like a stack of transparencies put together to show different types of objects.

You can find out which layer an object is on in its specification dialog or by selecting the object and looking at the Status Bar. And, you can customize how each layer displays in the Layer Display Options dialog. See *The Status Bar on page 24* and *Layer Display Options Dialog on page 179*.

Multiple layers are organized into Layer Sets, which are designed to help you perform different tasks efficiently or produce specific views for your construction documents or for presentation purposes. You can customize the display settings for individual layer sets and can also copy, add and delete layer sets. See *Layer Sets on page 182*.

Different types of 2D and 3D views use their own layer sets. You can specify the initial layer set used by a particular type of view in the Layer Set Defaults dialog. See *Layer Set Defaults on page 183*.



# Layer Attributes

The display of objects in different views is controlled by layer sets and layers in the Layer Display Options dialog. See [Layer Display Options Dialog on page 179](#).

## IN-USE LAYERS

A layer is considered to be in use in the current plan or layout file if one or more objects are assigned to it; if it is selected in one or more defaults dialogs; or, if it is a system default layer for one or more drawing tools.

In the Layer Display Options dialog, the **Used** column identifies in use layers:



Indicates that one or more objects are assigned to the layer.



Indicates that there are no objects on the layer, but that it is specified in a defaults dialog.



Indicates that the layer is not used elsewhere, but is a system default layer.

Move your mouse pointer over an icon to display a tool tip summarizing where the layer is in use.

## PRIMARY AND SECONDARY LAYERS

Every object is placed on a layer which controls whether it displays in a given view. This layer is referred to as the object's primary layer, and you can see its name in the Status Bar when the object is selected. See [The Status Bar on page 24](#).

In addition, some objects have secondary layers which may alter the appearance of objects on the primary layer, but do not control whether the objects display or not.

For example, the default primary layer for base cabinets is "Cabinets, Base". In addition, base cabinets have a number of secondary layers that control the display of the countertop, face indicators, door opening indicators, module lines and labels.

Note: If an object's primary layer is turned off, information on its secondary layers will not display - even if those layers are turned on.

You can view a list of an object's primary and secondary layers by selecting it and clicking the **Object Layer Properties**  edit button. See [Object Layer Properties on page 187](#).

## IN PLAN AND 3D VIEWS

All layers with a check in the **Disp** column display when the current layer set is active. Objects that are not displayed cannot be seen or selected. If you try to place or draw an object on a layer that is hidden, the program asks if you want to turn the layer on.









Name	Used	Disp	Lock
Architectural Blocks	S	✓	
Architectural Blocks, Labels	S		
Audio/Video	S	✓	
Auto Dormers	Ⓚ	✓	
Cabinets, Base	Ⓚ	✓	

Some objects are designed to be inserted into another object rather than standing alone. If the display of an object that contains an inserted object is turned off, the inserted object’s display will be turned off, as well. For example, if the display of a wall is turned off, any doors and windows in that wall will not display either. See [Inserted Objects on page 973](#).

Only displayed objects are included when DXF/DWG and EMF files are exported, and only displayed objects print.

## LINE AND TEXT STYLES

A layer’s **Color**, **Weight**, **Line Style** and **Text Style** attributes determine how an object on that layer appears in plan view. These attributes also affect Surface Edge Lines in 3D views using the Vector View Rendering Technique. The Color attribute is also used for Surface Edge Lines in Technical Illustration renderings. See [3D View Defaults Dialog on page 1083](#).

Color	Weight	Line Style	Text Style
	25		Default Text Style
	25		Default Text Style
	10		Default Label Style
	25		Default Text Style

Many objects, including all CAD and text objects, allow you to override these settings for an individual instance without changing its layer. See [Line Style Panel on page 305](#).

## EDGE AND PATTERN LINES











In 3D Vector Views, objects are represented using lines to define their surface edges. By default, Edge Lines use the attributes set for the object’s layer, as described above.

Some CAD-based architectural objects, such as Slabs, have line style settings in their specification dialogs; however, these specifications are not used unless **Use Object Settings** is checked in the 3D View Defaults dialog. See [3D View Defaults Dialog on page 1083](#).

In addition, a material applied to an object surface may have a pattern associated with it. Pattern line color, weight, and spacing is set in the Define Material dialog. See [Pattern Panel on page 1067](#).

## LOCKING LAYERS

Objects on layers with a lock icon in the **Lock** column cannot be selected by the user.

Name	Used	Disp	Lock
Roofs, Gutters		<input type="checkbox"/>	
Roofs, Labels		<input type="checkbox"/>	<input type="checkbox"/>
Roofs, Openings		<input checked="" type="checkbox"/>	<input type="checkbox"/>
Roofs, Overhang Area		<input type="checkbox"/>	
Roofs, Ridge Caps		<input type="checkbox"/>	
Roofs, Trim		<input type="checkbox"/>	

New objects cannot be drawn on a locked layer, either. If you lock a layer and then attempt to draw a new object on that layer, a message box will ask you to unlock the layer.

Layers with objects that you need to see as a reference while working, but not select, are good candidates for locking. For example:

- Locking the “Rooms” layer can make it easier to select objects located inside rooms.
- Locking the “Roof Planes” layer can make it easier to select objects located under the eaves.

Another use for locking layers is to protect them from editing in plans opened by clients or others in select Home Designer programs. See [Opening Chief Architect Plans in Home Designer Programs on page 35](#).



Locking a layer does not prevent objects on that layer from being modified. In addition, most objects can be deleted using the Delete Objects dialog. Objects are also deleted if the floor they are placed on is deleted. See [Deleting Objects on page 284](#).

## COPYING AND PASTING

If you place an object on a renamed or custom layer and then paste it into a new plan or layout file, a new layer will be created in the destination file. See [Copying and Pasting Objects on page 167](#).

---



# Layer Display Options Dialog



The Layer Display Options dialog controls the display of layers in a selected layer set. From any view, select **Tools> Layer Settings> Display Options** to open this dialog.

The Layer Display Options dialog consists of a table that lists all layers and their attributes. See [Layer Attributes on page 177](#).

There are a number of dialogs similar to Layer Display Options in the program:

- The **Object Layer Properties**  edit tool allows you to access and edit the layer or layers associated with one or more selected objects. See [Object Layer Properties on page 187](#).
- Select **Tools> Layer Settings> Display Options**  in a layout to open the Layout Page Display Options dialog. See [Layout Page Display Options on page 1334](#).
- The Layer Display Options dialog is also available for views sent to layout. See [Displaying Layout Views on page 1344](#).
- The Layer Display Options dialog can also be accessed via the Materials List Specification dialog, in which case it will only have the **Name** and **Disp** columns in the table of layers. See [Options Panel on page 1314](#).

To edit the attributes of a Reference Floor Layer Set, click the **Define** button in the Change Floor/Reference dialog. See [The Reference Display on page 738](#).

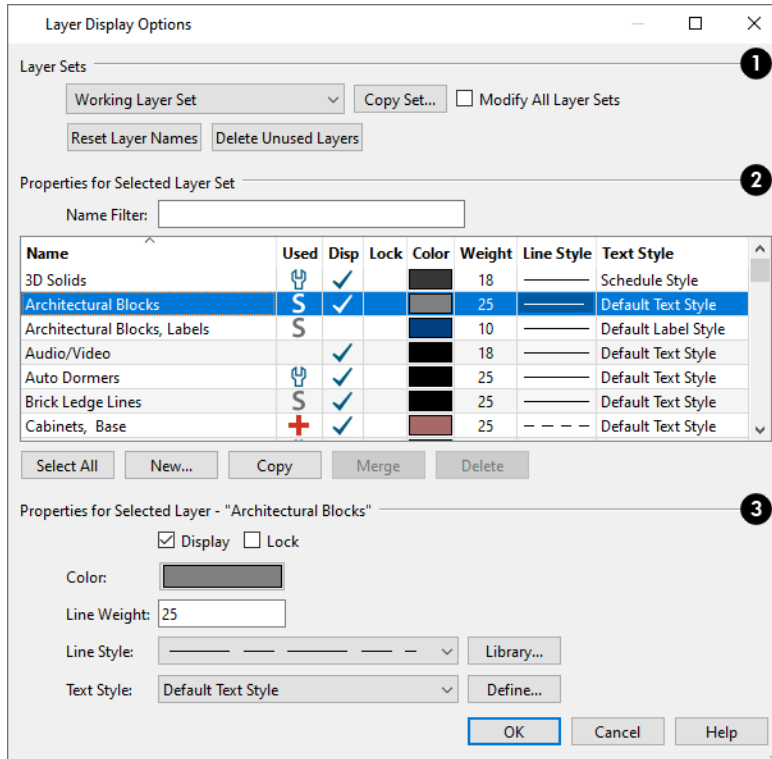

## 1 Layer Sets

The **Layer Sets** options let you specify which layer set - or sets - is affected by changes made in this dialog as well as which layer set is active in the current view. These options are not available in the Object Layer Properties dialog.

- The currently active layer set displays in the drop-down list.
- Click the **Copy Set** button to create a copy of the current layer set.
- Check **Modify All Layer Sets**, then make changes to one or more layer's attributes and click OK. The changes will be applied to the layer(s) in all layer sets. See *Modify All Layer Sets on page 183*.

 Modify All Layer Sets is a one-time action. It is always unchecked when the Layer Display Options dialog is opened.

- Click the **Reset Layer Names** button to restore the original names to any system layers that have been renamed in the current file. Not available in the Active Layer Display Options side window. See *Active Layer Display Options on page 185*.
- Click the **Delete Unused Layers** button to remove any layers in the current file that are not in use. Not available in the Active Layer Display Options side window. See *In-Use Layers on page 177*.

## 2 Properties for Selected Layer Set

The **Properties for Selected Layer Set** are presented in a table of layers and their attributes. You can filter the names that display in the list by typing in the **Name Filter** text field. When nothing is typed in this field, all layers display. You can also click a column header to sort all layers in the table by that column. An arrow above a column indicates that it is being used to sort the table, and in which direction it is being sorted.

The **Name** column is sorted alphabetically. Layers are named so that similar object types are listed near one another, and sorting is case sensitive to allow greater control over organization. Double-click a layer in the **Name** column to rename it.

- An icon in the **Used** column indicates that the layer is in use. The information in this column can be sorted, but not edited here. See *In-Use Layers on page 177*.
- A check in the **Disp** column indicates which layers are set to be visible. If a layer is turned off, this column is blank.
- A lock icon  in the **Lock** column indicates which layers are locked, preventing objects on that layer from being selected. See *Locking Layers on page 178*.
- The **Color** column shows the line color for each layer and can be sorted so that like colors are listed together.
- The **Line Style** column shows the line style for each layer and can be sorted so that like line styles are listed together.
- The **Line Weight** column displays the line weight used by each layer and can be sorted so that like line weights are listed together. See *Line Weights on page 1374*.
- The **Text Style** column shows the text style assigned to each layer and can be sorted so that layers using the same style are listed together. See *Text Styles on page 538*.

The buttons below the table offer additional control over the layers in the table.

- Click the **Select All** button or press Ctrl + A to select all layers in the table at once. This allows changes to be quickly applied to all layers.
- Click the **New** button to open the New Layer Name dialog and create a new layer with a unique name of your choice. Duplicate layer names are not allowed.

Note: New layers are added to all layer sets. However, in all but the current layer set, their display will be turned off.

- Click the **Copy** button to create a copy of the selected layer. The new layer is added directly below the original in the table.
- When two or more non-system layers are selected, click the **Merge** button to consolidate them into a single layer. The layer selected first is retained and the others are merged into it. Any objects on those merged layers or defaults set to use those merged layers are moved to the remaining layer.
- Click the **Delete** button to delete the selected layer. You cannot delete used layers or any of the system layers used by Chief Architect.
- Click the **Reset Names** button to revert layer names for system layers back to the original names that installed with Chief Architect. This does not affect layers you created.
- Click **OK** to close the dialog and apply your changes.
- Click **Cancel** to close the dialog, ignoring any edits.

Layers are selected by clicking on them in the table. Hold down the Shift key or the Ctrl key to select multiple layers at once. Press Ctrl + A or click the **Select All** button to select all layers in the table. When selected, a layer's attributes display and can be edited below.

 The program remembers what layer(s) are selected when you click OK and selects them again when you return to this dialog.

### **3** Properties for “Selected Layer”

The **Properties for “Selected Layer”** options let you modify the attributes of one or more selected layers. Line Color,

Style, and Size affect lines in plan view and surface edge lines in Vector Views. When multiple layers are selected, “No Change” may display for attributes that are not shared by the selected layers.

- To turn off a selected layer, uncheck **Display**. See *Layer Attributes on page 177*.
- To protect the objects on a selected layer from accidental changes, check **Lock**. Items on locked layers can display but cannot be selected. See *Locking Layers on page 178*.
- To change the color of lines on a selected layer, click the **Color** bar to open the Select Color dialog. See *Color Chooser/Select Color Dialog on page 203*.
- Specify the default **Line Weight**, or thickness, for objects on the selected layer. See *Line Weights on page 1374*.
- To change the **Line Style** of a selected layer, click the drop-down arrow or the **Library** button to select a line style from the library. See *Line Styles on page 199*.
- To change the **Text Style** of a selected layer, click the drop-down arrow or click the **Define** button to open the Text Style Defaults dialog. The **Define** button is not available when multiple layers with different Text Styles are selected. See *Text Styles on page 538*.

Note: Not all objects display in all views. For instance, invisible walls do not appear in camera views or materials lists, regardless of the layer they are placed on or whether that layer is turned on or not.

---

## Layer Sets

**Layer Sets** are used to control the layer settings for different views in a plan or layout file. All views associated with a plan file - including views sent to layout - make use of layer sets stored in that **.plan** file.

A layer set consists of a complete list of the layers in the current plan or layout along with the display settings for each layer as set for a particular type of view or purpose. These display settings can be modified, and can be different for each layer set. See *Layer Display Options Dialog on page 179*.

Any changes made to a layer set in one view affects all other views using the same layer set. If this is not desired, you can create a unique layer set for a particular view. See *Layer Set Management on page 184*.

Layer sets are file specific, which means that changes made in one plan or layout file have no effect on the settings in other files. If you find that you use the same settings often, you should consider adding these layer sets to your template files. See *Template Files on page 87*.

Layer sets are also view specific, so you can use a different layer set in each plan view, camera view, cross section/elevation view, and CAD Detail if you wish. See *View Windows on page 144*.

### ACTIVATING A LAYER SET

There are five ways to activate a Layer Set:

- Select a Layer Set from the **Active Layer Set Control**  **Layer Set** ▾ drop-down. This control is available in camera views and can be added to the toolbars for other view types as well. See *To add a button to a toolbar on page 132*.
- Activate a Default Set. See *Default Sets on page 83*.
- Open a saved view in which the Layer Set was previously active.

- Select a **Layer Set** in the Active Layer Display Options side window. See *Active Layer Display Options on page 185*.
- Select a **Layer Set** in the Active Defaults dialog. See *Active Defaults Dialog on page 82*.

## LAYOUT LAYER SETS

Views sent to layout use layer sets saved with the plan, rather than with the layout. See *Displaying Layout Views on page 1344*.

## LAYER SETS AND TEMPLATES

Layers and layer sets are plan-specific. A custom layer set that you created in one plan file may not be available in another. To include a custom layer set in all new plan files, add it to your template plan. See *Exporting and Importing Layer Sets on page 189* and *Template Files on page 87*.

## MODIFY ALL LAYER SETS

If you want changes made in one layer set to apply to all other layer sets in the current plan, check **Modify All Layer Sets** in the Layer Display Options dialog before making changes. The layer name and display attributes are applied to all other layer sets.

For example, if you check **Modify All Layer Sets** and then change the color and line style for the Text layer of the Electrical Set, the same changes are applied to the Text layer of the Framing Set of the same plan.

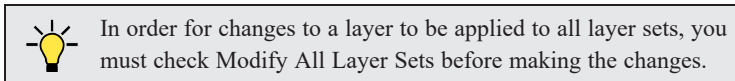

## LAYER SET DEFAULTS

Whenever a particular type of view is created, such as floor plan view or a framing overview, a specific layer set is activated for that view. Which layer set becomes active depends on the type of view created.

The default layer sets for nine different view types, including the Reference Floor, are specified in the Layer Set Defaults dialog.

Each of these layer sets can be edited as needed in the Layer Display Options dialog. See *Layer Display Options Dialog on page 179*.

Normally, it is best to change the settings in the existing default layer sets rather than select different default layer sets, but you can do so if needed. See *Layer Set Defaults on page 183*.

---

# Layer Set Defaults



The Layer Set Defaults dialog is used to specify the initial layer sets for a variety of special view types. Select **Edit> Default Settings** to open the Default Settings dialog, then select “Layer Sets” from the list and click the **Edit** button. See *Default Settings on page 77*.

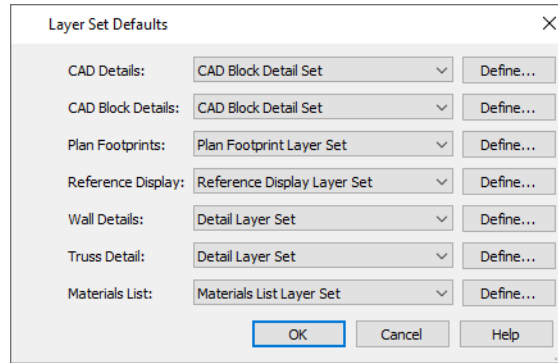

When a new view window is created, Chief Architect sets the default layer set listed here as the active layer set for that view type. See [View Windows on page 144](#).

- Click the drop-down list to change the initial layer set for each type of view.
- Select “Use Active Layer Set” from the list to use whatever layer set is currently active in the new view when it is created.
- Click the **Define** button to open the Layer Display Options dialog and change the layer settings for the layer set. See [Layer Display Options Dialog on page 179](#).

The default layer sets for camera views can be set in the Camera Defaults dialogs. See [Camera Defaults Dialogs on page 1081](#).

## Layer Set Management

The Layer Set Management dialog lists the layer sets available in the current plan or layout file and lets you add and remove layer sets and modify and copy existing layer sets. Select **Tools> Layer Settings> Layer Set Management** to open this dialog.

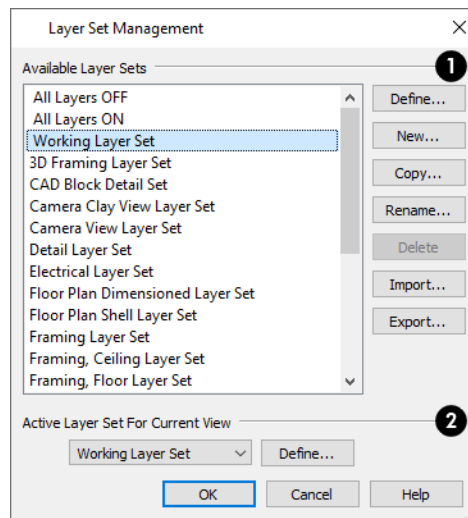

### 1 Available Layer Sets

Use the **Available Layer Sets** options to manage the layer sets saved with the current plan or layout file.



- Click on a layer set name in the list to select it.
- Click the **Define** button or double-click on the layer set name to open the Layer Display Options dialog and make changes to the selected layer set.
- Click the **New** button to open the New Layer Set Name dialog and create a new layer set based on system default settings.
- Click the **Copy** button to open the New Layer Set Name dialog and create a new layer set based on a copy of the currently selected layer set.
- Click the **Rename** button to open the Rename Layer Set dialog and type a new name for the selected layer set. Not available for the Default Set.
- Click the **Delete** button to delete the selected layer set from the current file. The Delete button is enabled if the layer set can be deleted: you cannot delete the active layer set, the Default Set, or any layer set in use as a default.

Do not delete any layer sets that are used by a layout.

- Click the **Import** button to import layer settings from a .layers file. See [Exporting and Importing Layer Sets on page 189](#).
- Click the **Export** button to export the layer settings in the current plan in a .layers file.

## 2 Active Layer Set for Current View

The **Active Layer Set for Current View** options affect only the layer set used in the view that was active when the Layer Set Management dialog was opened.

- Select a new **Active Layer Set** from the drop-down list or click the **Define** button to make changes to the active layer set in the Layer Display Options dialog.

---

## Active Layer Display Options



The **Active Layer Display Options** side window allows you to access the layer settings for the currently active Layer Set or the Object Layer Properties for the currently selected object. Select **View> Active Layer Display Options** to open or close this side window.

- When no object is selected, the settings for the active Layer Set are shown. See [Layer Sets on page 182](#).
- When one or more objects are selected, the objects' Object Layer Properties are shown. See [Object Layer Properties on page 187](#).

The list of layers and the options for editing their attributes are similar to those in the Layer Display Options dialog. See [Layer Display Options Dialog on page 179](#).

Click the **Options**  button at the bottom of the side window to specify what settings and information are presented:

- Select **Layer Set Control** to display the Layer Set drop-down list at the top of the side window. The name of the active layer set is stated and can be changed here.
- Select **Layer Management** to display the Reset Layer Names and Delete Unused Layers buttons.
- Select **Layer Name Filter** to display the Name Filter text box above the layer table. Type in this field to filter the names shown in the table; when nothing is typed, all relevant layers are listed.
- Select **Layer Edit Buttons** to display the Select All, New, Copy, Merge, Delete, and Reset Names buttons below the layer table.
- Select **Layer Properties** to display the Properties for Selected Layer settings below the label table.

- Select **Show All Layers** to list all layers in the table, even when an object is selected.
- Select which **Columns** to include in the table.

By default, when the Active Layer Display Options side window is opened, it will be docked on the right side of the program window. Like other side windows, though, it can be moved. See [Side Windows on page 17](#).

## Select Layer Dialog

The Select Layer dialog allows you to select a layer for one of two purposes:





Select **CAD> Current CAD Layer** to open this dialog and specify which layer is the Current CAD Layer. See [Current CAD Layer on page 326](#).



This dialog also opens when the **Layer Painter** tool is used. See [Layer Painter, Eyedropper, and Hider on page 188](#).

The Current CAD Layer and Layer Painter buttons can be added to your toolbars. See [To add a button to a toolbar on page 132](#).

The Select Layer dialog contains the table of layers and Name Filter found in the Layer Display Options dialog. See [Layer Display Options Dialog on page 179](#). Click on a layer in the table to select it, then click OK.

- If the dialog was opened using the **Current CAD Layer**  tool, the selected layer will become the Current CAD Layer.
- If the dialog was opened using the **Layer Painter**  tool, you can click on objects in the current view to assign them to the selected layer.

## Layer Panel

The LAYER panel is found in the specification dialogs for many different objects. Here you can specify the layer that the program uses to display the selected object.

Note: In some specification dialogs, layer information is located on the Line Style or Appearance panel rather than the Layer panel.

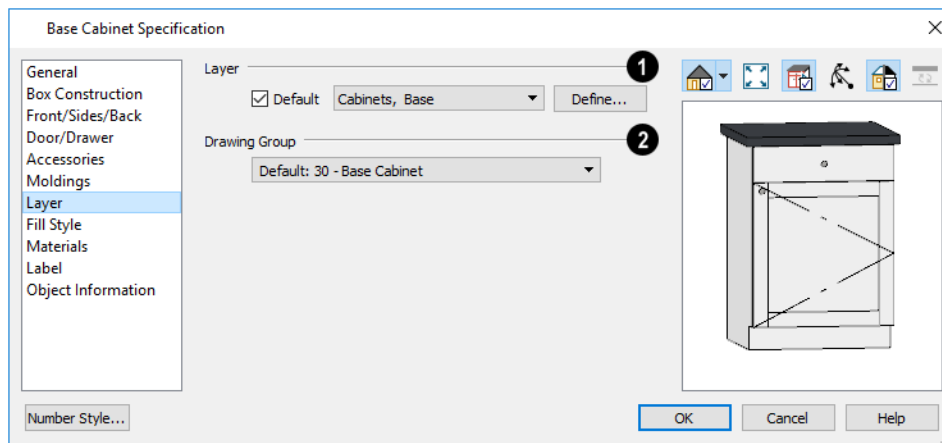

### 1 Layer

Specify the layer that the selected object(s) is located on.

- Check **Default** to place the selected object on the default layer for that object type. See *Dynamic Defaults on page 79*.
- Click the drop-down list to select a layer from those available in the current file.
- Click **Define** to open the Layer Display Options dialog and select, modify, or add a new layer. See *Layer Display Options Dialog on page 179*.

## 2 Drawing Group

See *Drawing Groups on page 190*.

# Object Layer Properties

 The **Object Layer Properties** edit tool allows you to access and edit the layer or layers associated with one or more selected objects. See *Primary and Secondary Layers on page 177*.

Some objects, such as CAD lines, only have one layer associated with them. Other objects, including many architectural objects like cabinets, have multiple layers that affect their display in various views. A few objects, such as active camera symbols and layout boxes, do not have this edit tool.

When you click the **Object Layer Properties**  edit button, the Object Layer Properties dialog opens.

The settings in this dialog are similar to those in the Layer Display Options dialog. See *Layer Display Options Dialog on page 179*.

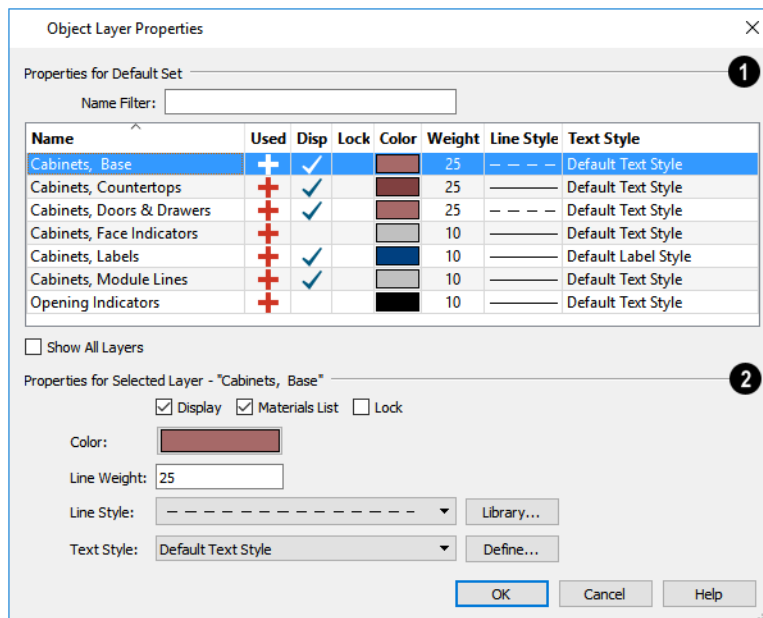

## 1 Properties

The **Properties** of the selected object(s) layers in the currently active layer set display in the table. The name of the currently active layer set is included in this heading. See *Layer Sets on page 182*.

- Type in the **Name Filter** text field to filter the names that display in the list below. When nothing is typed in the field, no layers are suppressed.

- A table listing the layers associated with the selected object(s) displays here. This sortable table functions like that in the Layer Display Options dialog.
- Check **Show All Layers** to list all layers in the current file rather than just those associated with the selected object. When unchecked, only the layers associated with the selected object(s) display.

## 2 Properties for Selected Layer

The **Properties** of the selected layer(s) display and can be edited here.

- As in the Layer Display Options dialog, when multiple layers with different properties are selected, drop-down lists may display “No Change” and check boxes may have a solid fill. See [Dialogs on page 19](#).

---

## Layer Painter, Eyedropper, and Hider





The **Layer Painter** and **Layer Eyedropper** tools allow you to move an object to any layer in any view without opening its specification dialog.





The **Layer Hider** tool lets you turn off the display of any layer in the currently active layer set by clicking on an object on that layer.



### To use the Layer Painter

1. In any view, select **Tools> Layer Settings> Layer Painter** .
2. In the Select Layer dialog, choose a layer and click OK. Your cursor will display the painter  icon. See [Select Layer Dialog on page 186](#).
3. Note that the name of the layer being painted is noted on the left side of the Status Bar at the bottom of the program window. See [The Status Bar on page 24](#).
4. Move your cursor over an object and notice that the Status Bar now states both the layer being painted and the current layer of the target object.
5. Click on objects in the view to move them to the selected layer.

### To use the Layer Eyedropper

1. In any view, select **Tools> Layer Settings> Layer Eyedropper** .
2. Click on an object to load the layer it is on into the Layer Painter.
3. Your cursor will display the painter  icon, and you can click on other objects to place them on the selected layer.

### To use the Layer Hider

1. In any view, select **Tools> Layer Settings> Layer Hider** .
2. Your cursor will display the layer  icon.
3. Move your cursor over an object and notice that the Status Bar states the object's primary layer.
4. Click on the object to turn off the display of its primary layer in the currently active layer set. See [Layer Sets on page 182](#).

## Exporting and Importing Layer Sets

Layer sets created in one plan can be exported as a **.layers** file and imported into other plans. This is a convenient alternative to re-creating one or more layer sets that may already exist in another plan.

### EXPORTING LAYER SETS



To export layer sets from the current plan or layout file, select **File> Export> Export Layer Sets** or click the **Export** button in the Layer Set Management dialog.

The Save Layer Set File dialog is a typical Save File dialog. Exported layer set files use the **.layers** file extensions. See [Exporting Files on page 41](#).

### IMPORTING LAYER SETS



To import layer sets into the current plan or layout, select **File> Import> Import Layer Sets** or click the **Import** button in the Layer Set Management dialog.

The Import Layer Set File dialog is a typical Open File dialog. See [Importing Files on page 45](#).

When the desired **.layers** file is selected, click **Open**. The Import Layer Sets dialog will open next.

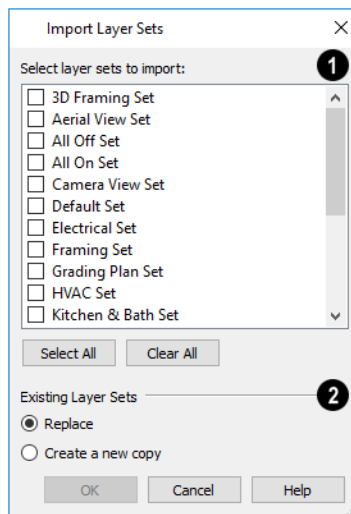

#### 1 Layer Sets to Import

Specify which layer sets you would like to import.

- Check the box beside the name of each layer set that you would like to import.
- Click the **Select All** button to select all sets in the list.
- Click the **Clear All** button to deselect all sets in the list.

#### 2 Existing Layer Sets

Specify how to handle **Existing Layer Sets** in the current file that have the same names as layer sets being imported.

- When **Replace** is selected, any layer sets in the current file with names identical to those being imported are deleted and replaced with imported sets.
- Select **Create a New Copy** to retain all existing layer sets and rename imported layer sets by appending them with a 2. If a layer set with the same name is imported later, this number is increased.

## Drawing Groups

Each object in a plan or layout file belongs to a Drawing Group, which influences whether it displays in front of or behind other objects. Drawing Groups control the display of objects in plan view, CAD Details, and on the layout page. They also control the display of CAD objects drawn in cross section/elevation views. They do not affect the display of objects in camera views and overviews.

Most categories of objects have their own Drawing Group; however, a few objects are instead placed in the Front or Back Group. Imported pictures, which are placed in the Back Group, are a notable example. A selected object's Drawing Group is reported in the Status Bar. See [The Status Bar on page 24](#).

Within a given Drawing Group, drawing order is determined by the order in which objects are placed. By default, an object will display in front of any objects that were created before it was. For example, if you place a chair and then a table, the table will display in front of the chair; if you instead place a table and then the chair, the chair will display in front.

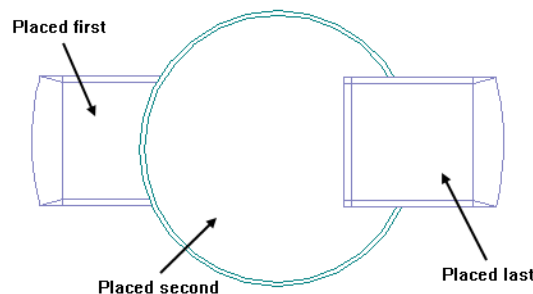

Drawing order also affects how objects are selected. If two objects are positioned so that they overlap one another, and you click at a point that they both share, the frontmost object will become selected first. See [Select Next Object on page 211](#).

### DRAWING GROUP EDIT TOOLS

 Once an object has been placed, its position in the drawing order can be modified. To do this, select one or more objects and click the **View Drawing Group Edit Tools** edit button.

There are two options for moving a selection towards the back of the drawing order:



Click the **Send to Back** edit button to move the selected object(s) to the back of the Back Group so it displays behind all other objects.



Click the **Send Backward** edit button to move the selected object(s) to the back of its current Drawing Group. If it is already at the back of its current group, it will be moved to the next group down in the drawing order.

There are two options for moving a selection towards the front of the drawing order:



Click the **Bring to Front** edit button to move the selected object(s) to the front of the Front Group so that it displays in front of all other objects.



Click the **Bring Forward** edit button to move the selected object(s) to the front of its current Drawing Group. If it is already at the front of its current group, it will be moved to the next group up in the drawing order.

## SELECT DRAWING GROUP DIALOG

The **Select Drawing Group** edit button reports the Drawing Group number that the selected object(s) is in. When multiple objects are selected, a horizontal line may display instead. Click this button to open the Select Drawing Group dialog.

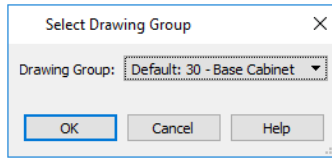

- Select a Drawing Group from the drop-down list to place the selected object(s) into that group. The default group for the selected object is noted as such.
- When multiple objects in different groups are selected, “No Choice” will initially display. You can select “Default: Multiple Values” to return each object to its respective default group.

You can specify the default Drawing Group for most types of objects in their defaults dialogs. See [Default Settings on page 77](#).

You can also assign a selected object to a particular **Drawing Group** in its specification dialog. See [Line Style Panel on page 305](#) and [Layer Panel on page 186](#).

# Display Toggles

There are a number of toggles and tools that can be used to affect the appearance of the on-screen display.

## PRINT PREVIEW



**Print Preview** and its related display toggles allow you to get a sense of what the current view will look like when it is printed. See [Print Preview on page 1371](#).

## REFRESH DISPLAY



**Refresh Display** redraws the current window to clean up extra lines, show missing items, and correct random on-screen effects caused by changes to a model. Select **View > Refresh Display** or press the F5 key to refresh the on-screen display.

## COLOR ON/OFF





The display of color on-screen can be toggled on and off in any view by selecting **View > Color** or by clicking the toggle button.



- If **Color** is toggled off in any 3D view other than a Vector View or a Hand Drawn Lines rendering, the view will be displayed in grayscale.
- If **Color** is toggled off in any line based view, including plan view, Vector Views, Hand Drawn Lines rendering, CAD Details, and layout, the view will be displayed either in black and white or grayscale, depending on the **Color Off Is** setting in the Preferences dialog. See [Appearance Panel on page 95](#).

The Color toggle can be set on a view by view basis and can be saved in the Plan View Specification dialog, Camera Specification and Cross Section/Elevation Specification dialogs. See [General Panel on page 149](#), [Camera Panel on page 1117](#) and [Camera Panel on page 1125](#).

### ***To display views in grayscale***

1. Select **View> Color**  to toggle color off.
2. Select **Edit> Preferences**  to open the Preferences dialog.
3. On the APPEARANCE panel, select **Grayscale** as the **Color Off Is** setting. See *Appearance Panel on page 95*.

### ***To display views in black and white***

1. Select **View> Color**  to toggle color off.
2. Select **Edit> Preferences**  to open the Preferences dialog.
3. On the APPEARANCE panel, select **Black and White** as the **Color Off Is** setting.

When **Color**  is toggled off and **Black and White** is specified, all lines appear as black, regardless of their color. Solid fill colors appear as either white or black, depending on which is closer to the actual fill color when Color is turned on. The background remains as defined in the Preferences dialog. See *Colors Panel on page 98*.

You can specify whether cross section/elevations, camera views, and overviews using the Vector View Rendering Technique are generated with colors turned on in the 3D View Defaults dialog. See *3D View Defaults Dialog on page 1083*.

You can also print in color, black and white, or grayscale. See *Print View Dialog on page 1380*.

## **ARC CENTERS AND ENDS**

 The display of arc center- and endpoints, and the display of circle center points can be toggled by selecting **View> Arc Centers and Ends**, by clicking the toggle button, or in the CAD Defaults dialog. See *Arc Centers and Ends on page 223*.

## **DELETE SURFACE**

 In any 3D view, select **3D> Delete Surface**, then click a surface in the view to temporarily remove the surface from the current view. See *Delete 3D Surface on page 1099*.

---

# **Fill Styles**

Fill styles are CAD-based patterns that can be used to fill the interiors of closed CAD shapes. In plan view, fill styles can also be applied to a variety of architectural objects. See *Fill Style Panel and Dialogs on page 193*.

The Fill Styles library contains fill styles that can be applied to objects individually in their specification dialogs, by default in their defaults dialogs, as well as using the **Fill Style Painter** tools.

You can use the **Place Library Object**  tool to create a custom toolbar button that has a fill style associated with it. See *Place Library Object Button on page 975*.

## **FILL STYLE EYEDROPPER AND PAINTER TOOLS**

 The **Fill Style Eyedropper** tool allows you to load a fill style assigned to an existing object into the Fill Style Painter and apply that fill style to other eligible objects.

Select **Tools> Fill Style Painter** to access the **Fill Style Painter** tools, which are used to apply fill styles to closed CAD objects. In plan view, the Fill Style Painter tools can be used to apply fill styles to a variety of architectural objects, as well.



These tools are similar to other Painter Tools in the program. See *Eyedropper and Painter Tools on page 277*.



## CUSTOM PATTERNS



If you do not find a pattern in the Library Browser that meets your needs, select **CAD> Patterns** to create your own custom patterns for use as fill styles and material patterns. See *Custom Patterns on page 196*.

## IMPORT PATTERNS



Select **File> Import> Import Patterns** to open the Import Custom Patterns file and import a **.pat** file. See *Importing Files on page 45*.

Patterns are imported directly to the User Catalog in the Library Browser and can be edited like other custom patterns. See *The User Catalog on page 961*.

---

# Fill Style Panel and Dialogs

The FILL STYLE panel is found in the specification dialogs for a variety of objects in the program. This panel is not available for Connect Electrical splines or Sprinkler Lines as these objects cannot be used to form closed shapes.

The settings on this panel are also found in a number of dialogs:

- To open the Fill Style Specification dialog, right-click on a fill style in the library and select **Open Object** or right-click on an unlocked library folder and select **New> Fill Style**. See *Using the Contextual Menu on page 951*.
- You can also create a new fill style by clicking the **Add New Fill Style**  button in the Select Library Object dialog. See *Select Library Object Dialog on page 974*.
- To open the Layer Fill Style dialog, click in the Fill column in the Wall Type Definitions or any Material Layers Definition dialog. See *Wall Type Definitions Dialog on page 387* and *Material Layers Definition Dialogs on page 1040*.
- The Default Framing and Default Header Fill Style dialogs can be accessed by clicking the **Fill Style** button on the PLAN DISPLAY and OPENINGS panels of the Build Framing dialog. See *Build Framing Dialog on page 860*.

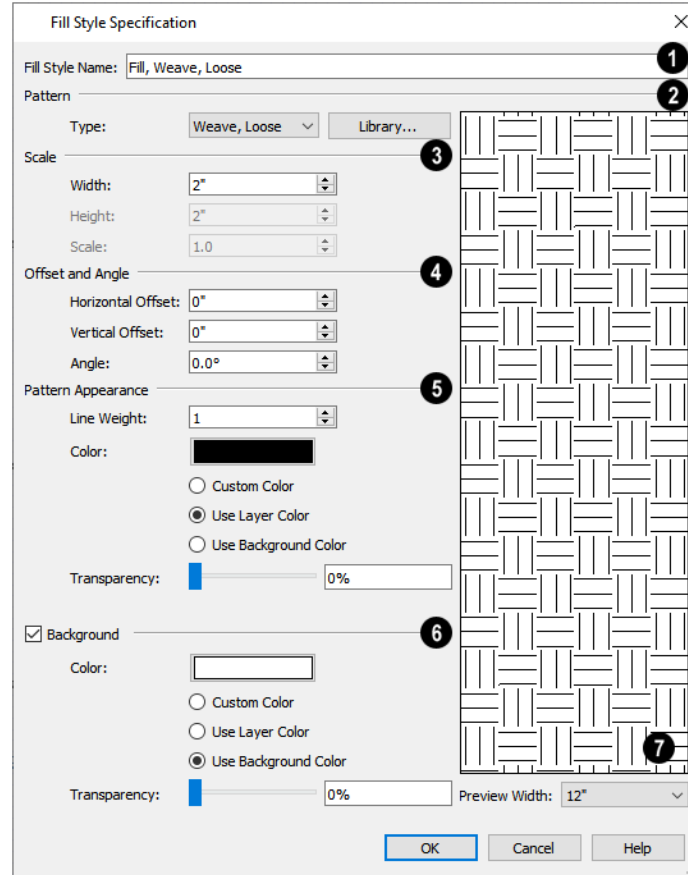

### 1 Fill Style Name

In the Fill Style dialog only, specify the **Fill Style Name**.

### 2 Pattern

Select a **Pattern Type** from the drop-down list and specify its characteristics.

- Select “Library” from the list or click the **Library** button to choose a pattern from the library. When a Library fill style is selected, a custom name may display in the list instead of a system default Type. See *Assigned Items on page 974*.

 When a fill style from the library is selected, it is possible for some or all of the settings in this dialog to change.

### 3 Scale

Specify the fill style’s **Scale**.

- Specify the **Width** of the selected fill pattern. For Concrete and Sand fills, instead adjust the overall **Spacing**. Not available for Solid fill.
- Specify the **Height** of the selected fill pattern. Only available for the Grid fill Types, as well as Herringbone and U’s.

- Specify a **Scale** for the selected fill pattern. Only available when the name of a library fill style from the library is listed as the fill Type, above.

#### 4 Offsets and Angle

Specify the fill's **Offsets and Angle**.

- Specify the **Horizontal** and **Vertical Offsets**. See *Mapping Patterns and Textures on page 1062*.
- Specify the **Angle** of the selected fill pattern. Not available for Solid fill.

#### 5 Appearance

Additional **Pattern Appearance** settings control the fill's line weight and color.

- Set the **Line Weight** for the selected fill pattern. Not available for "Solid" fill.
- Specify a custom **Pattern Color** for the lines that make up the fill pattern or Solid fill by clicking the color bar. The Layer Color is used by default. See *Color Chooser/Select Color Dialog on page 203*.
- **Custom Color** is selected automatically if you click the color bar above.
- Select **Use Layer Color** to have the fill pattern use the layer color for the pattern lines or solid fill.
- Select **Use Background Color** to use the view's background color for the pattern lines or solid fill.
- Use the **Transparency** slider bar or text field to control how transparent the fill pattern lines are. This setting also affects the transparency of Solid fill colors.

#### 6 Background

Check **Background** to add a solid background color to the fill pattern and enable the settings below. When unchecked, the fill pattern has a transparent background. Not available when "Solid" is the selected Pattern Type.

- Specify a custom **Background Color** by clicking the color bar. The Background Color set in the Preferences dialog is used by default. See *Colors Panel on page 98*.
- **Custom Color** is selected automatically if you click the color bar above.
- Select **Use Layer Color** to have the fill pattern use the layer color for the pattern lines or solid fill.
- Select **Use Background Color** to use the view's background color for the pattern lines or solid fill.
- Use the **Transparency** slider bar or text field to control how transparent the background color is.
- On the FILL STYLE panel only, click the **Add to Library** button to add the fill pattern as it is currently defined to the User Catalog. See *Add to Library on page 965*.

#### 7 Preview

A preview of the selected pattern displays to the right. As changes are made to the settings on this panel, the preview will update.

- Choose a **Preview Width** from the drop-down list. This value controls how large an area the preview represents. The selected value indicates the horizontal width of the preview pane in actual plan inches (mm).

## Custom Patterns

If you do not find a pattern in the Library Browser that meets your needs, you can create your own custom patterns for use as fill styles and material patterns. See *Fill Styles on page 192* and *About Materials on page 1050*.

### CREATING CUSTOM PATTERNS

 To create a custom pattern for fill styles and material patterns, begin by drawing one tile of the pattern to scale using the CAD Tools, then group-select the objects that form the pattern tile and click the **Create Pattern** edit button to open the Pattern Specification dialog.

You can also create a new pattern by selecting **CAD> Patterns> Create New Pattern** or by right-clicking on the User Catalog in the Library Browser or a folder within it and selecting **New> Pattern** from the contextual menu. These options open a Pattern Window in which you can draw and edit a custom pattern.

The similar Edit Pattern Repeat Box dialog for an existing Pattern can be opened while in its Pattern Window either by selecting **CAD> Patterns> Edit Pattern Repeat Dimensions** by selecting the pattern tile's Repeat Box and clicking the **Open Object**  edit button. See Editing Custom Patterns, below.

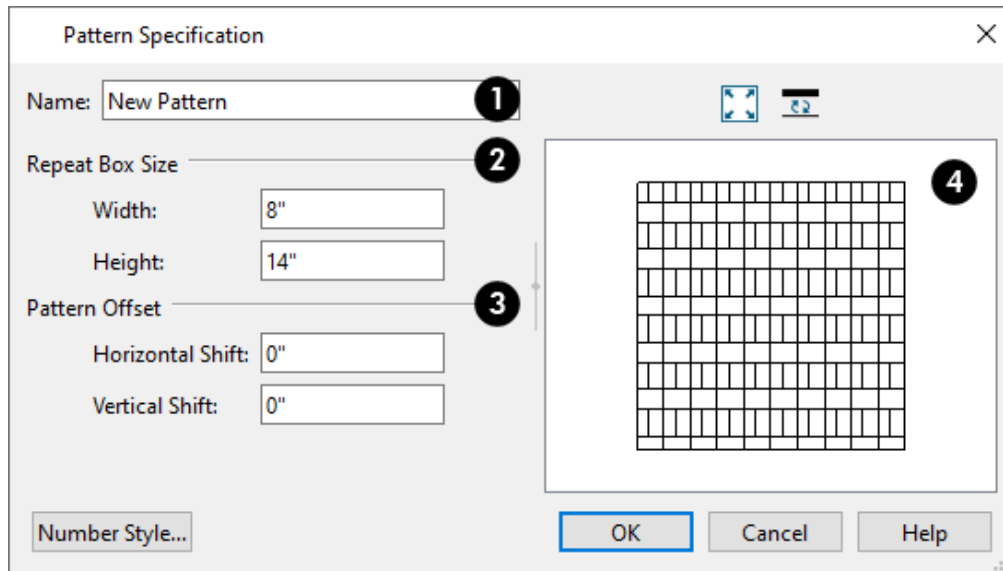

#### 1 Fill Name

In the Pattern Specification dialog only, specify a short, descriptive name for the new pattern. Not available in the Edit Pattern Tile dialog.

#### 2 Pattern Dimensions

- Specify the **Width** and **Height** of the pattern's Repeat Box.

#### 3 Pattern Offset

When these values are 0, the pattern tiles are laid out in a regular grid.

- Specify the **Horizontal Shift**, which offsets the rows of the pattern.
- Specify the **Vertical Shift**, which offsets the columns of the pattern.

#### 4 Preview

A preview of the pattern displays on the right. As changes are made to the settings in this dialog, the pattern in the preview will update. See *Dialog Preview Panes on page 22*.

When you click OK in the Pattern Specification dialog, the new pattern is created and added to the User Catalog in the Library Browser. See *The User Catalog on page 961*.

### EDITING CUSTOM PATTERNS



The **Edit Pattern** tool lets you make changes to a pattern once it has been created. To access this edit tool:

- Right-click on a pattern in the User Catalog of the Library Browser. See *Using the Contextual Menu on page 951*.
- Select an object using the pattern as its Fill Style. See *Editing Closed Polyline-Based Objects on page 228*.

When you click the **Edit Pattern** edit button, a Pattern window opens in which a single pattern tile is represented using the CAD objects used to create it. A Pattern window is similar to a CAD Detail: the objects in the view can be selected and edited, and the CAD, Dimension, and Text tools are available for use. See *CAD Details on page 337*.

Unlike regular CAD Details, however, the CAD Detail Management dialog is not available when a Pattern window is open. Layer settings in this view are customizable; however, when opened via the Library Browser, no changes are retained when the view is saved or closed. In addition, when you select Save Active View, the program updates the definition of the pattern: either assigned to the selected object or in the Library Browser.



If you would like your edited pattern to be available for future use, select **CAD> Patterns> Add Pattern to Library**. See *Add to Library on page 965*.

Pattern windows have three features: an uneditable Pattern Preview, an editable Pattern Tile composed of CAD objects, and a Pattern Repeat Box which is also editable.

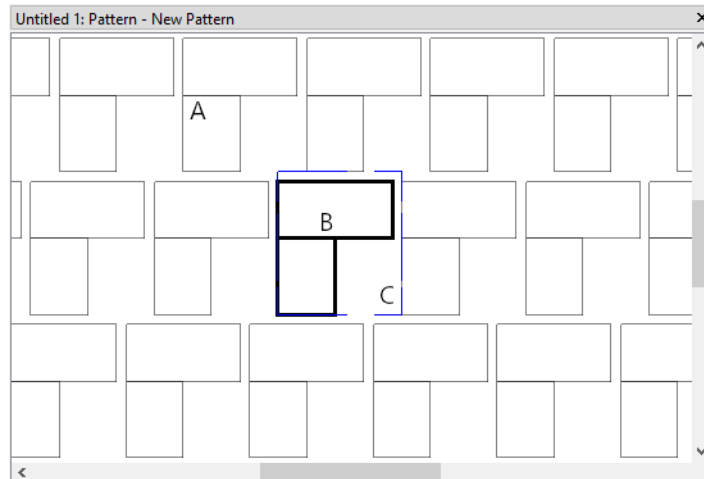

### A. Pattern Preview

- The Pattern Preview shows what the pattern looks like, including any offsets and space between tiles. The preview updates as changes are made to the Pattern Tile and Repeat Box. It can be toggled on/off by selecting **CAD> Patterns> Display Pattern Preview**  and its color and transparency can be set in the Preferences dialog. See *Pattern Editor Panel on page 101*.

### B. Pattern Tile

- The Pattern Tile is composed of CAD objects which you can select and edit to change the appearance of the pattern's lines. The Pattern Tile is drawn on the "CAD, Defaults" layer by default, and you can change the Pattern Tile's layer settings if you wish; however, your changes will not be saved with the pattern. See *Editing Line-Based Objects on page 216*.

### C. Pattern Repeat Box

- The Pattern Repeat Box controls how the pattern tiles. You can add spacing between tiles or create overlap either in its specification dialog or using its edit handles, and you can shift the pattern's rows and columns in its Pattern Repeat Box Specification dialog. Its color and line weight can be customized in the Preferences dialog. See *Creating Custom Patterns, above*.



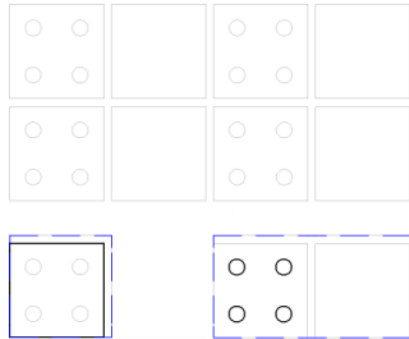

## PATTERN TILE GROUPS

Custom Patterns can be composed of multiple Pattern Tile Groups, each of which has its own tile pattern and Repeat Box. Although all groups are shown in the Pattern Preview, only one group is active and editable at a time.





This pattern has two Pattern Tile Groups with different tile patterns and Repeat Boxes

When a Pattern window is active, a selection of tools in the **CAD> Patterns** submenu allow you to create and navigate a pattern's Pattern Tile Groups:

-  **Next Pattern Tile Group** allows you to switch to groups that were created more recently than the current group.
-  **Previous Pattern Tile Group** allows you to switch to groups created before the current group.
-  **Add Pattern Tile Group** allows you to add a new Pattern Tile Group to the pattern.
-  **Delete Pattern Tile Group** removes the current group from the pattern.

## INFINITE PATTERN LINES

 In addition to the CAD, Dimension, and Text tools available in a Pattern window, you can select **CAD>Patterns> Infinite Pattern Line**, then click and drag to create an infinite line that draws and is replicated independent of any

Pattern Repeat Boxes. Select an Infinite Pattern Line and click the **Open Object**  edit button to open the Infinite Pattern Line Specification dialog.

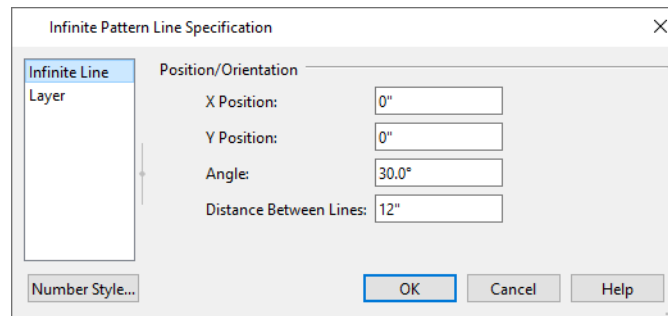

- When the **X** and **Y Position** values are 0, the Infinite Line passes through the lower left corner of the Pattern Repeat Box of the group that was active when it was drawn.
- Specify the Infinite Line's **Angle**.
- Infinite Pattern Lines are replicated within their pattern. Specify the **Distance Between Lines**.

---

## Line Styles

Line styles can be applied to objects by layer in the Layer Display Options dialog. See [Layer Display Options Dialog on page 179](#).

CAD and CAD-based objects can also be assigned a line style in their specification dialogs. See [Line Style Panel on page 305](#).

### LINE STYLES IN THE LIBRARY

A selection of line styles is available in the library, and additional styles can be created or imported into the User Catalog. You can draw a line that uses a selected style directly from the library. See [Line Tools on page 300](#).

#### *To draw with a line style from the library*

1. Select a line style in the Folders tree list or Filter Results list in the Library Browser. See [The Library Browser on page 946](#).
2. Click and drag in a 2D view to produce a CAD line with the selected style.
3. Continue drawing CAD lines with the same style until another line style or drawing tool is selected.

You can use the **Place Library Object**  tool to create a custom toolbar button that has a line style associated with it. See [Place Library Object Button on page 975](#).

### LINE STYLE MANAGEMENT

 Once a line style has been assigned to an object or a layer, it is saved in the plan or layout file. Select **CAD> Lines> Line Style Management** to access a list of the line styles saved in the current file in the Line Style Management dialog.

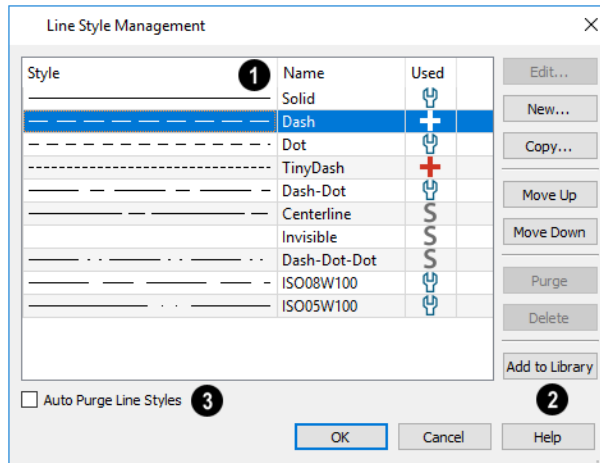

## 1 Line Styles

All line styles saved in the current file are presented in a table. Click a column header to sort all line items in the table by that column. An arrow above the column indicates that it is being used to sort the table, and in which direction it is being sorted. Line Styles that are not currently assigned to a layer, an object, or a default may also be included in the list.

- Click on a line style to select it. Multiple line items can be selected, as well. See *Shift and Ctrl Select on page 214*.
- The **Style** column shows a sample of each line style.
- The **Name** of each line style is listed. Click in this column and type a letter to locate names that begin with that letter.
- Line styles with at least one instance in the current file have a plus sign in the **Used** column. See *In Use Line Styles on page 201*, below.
- Move your mouse pointer over a plus sign. A tool tip will summarize where the line style in question is in use.
- Unused line styles have no icons in the Used column and can be deleted.

## 2 Edit Buttons

The buttons on the right allow you to add, edit, remove, and reorganize the items in the list.

- Click the **Edit** button to open the Line Style Specification dialog for the selected line style. See *Line Style Specification Dialog on page 201*.
- Click the **New** button to open the Line Style Specification dialog and create a new line style.
- Click the **Copy** button to make a copy of the selected line style and add it to the list. The new line style has the same name as the original, appended with a number.

Note: Line styles created in Chief Architect are not retained in views exported to .dxf/.dwg. See *Exporting 2D DXF/DWG Files on page 1235*.

The items in this list and their order are also found in the Style drop-down list found in various object specification dialogs. See *Line Style Panel on page 305*.

- Click the **Move Up** button to move one or more selected line styles up one position in the list.
- Click the **Move Down** button to move one or more selected line styles down one position in the list.



- Click the **Purge** button to delete all unused line styles from the list.
- Select an unused line style and click the **Delete** button to remove it from the list.
- Click the **Add to Library** button to add the selected line style to the User Catalog. See *Adding Library Content on page 965*.

### 3 Auto Purge Line Styles

When Auto Purge Line Styles is unchecked and all instances of a line style are removed from the current file, it will continue to be saved in the file and listed here. Check this box to remove unused line styles from the file.

## IN USE LINE STYLES

A line style is considered to be in use in the current plan or layout file if it is assigned to one or more objects; if it is selected in one or more defaults dialogs; or, if it is a system default line style.

In the Line Style Management dialog, these icons are shown **Used** column:



A red plus sign indicates that the line style is assigned to one or more objects.



A white wrench indicates that the line style is specified in a defaults dialog but is not assigned to any objects currently.



A grey S indicates that the line style is not used elsewhere, but is a system default.

Move your mouse pointer over an icon to display a tool tip summarizing where the line style is in use.

These icons are also used in the CAD Block Management dialog. See *CAD Block Management on page 333*.

## IMPORT LINE STYLES





Select **File> Import> Import Line Styles** to open the Import Line Styles dialog and import a **.lin** or **.dat** file. See *Importing Files on page 45*.

Line styles are imported directly to the User Catalog in the Library Browser. See *The User Catalog on page 961*.

---

# Line Style Specification Dialog

The Line Style Specification dialog allows you to create new line styles for use in Chief Architect Premier. There are several ways to open this dialog:

- Click the New or Copy button in the Line Style Management dialog. See *Line Style Management on page 199*.
- Right-click on an unlocked library folder and select **New> Line Style**. See *Adding Library Content on page 965*.
- Click the **Add New Line Style**  button in the Select Library Object dialog. See *Select Material/Library Object Dialog on page 1056*.
- Right-click on a line style in the User Catalog, then select **Open Object**  from the contextual menu. See *Using the Contextual Menu on page 951*.

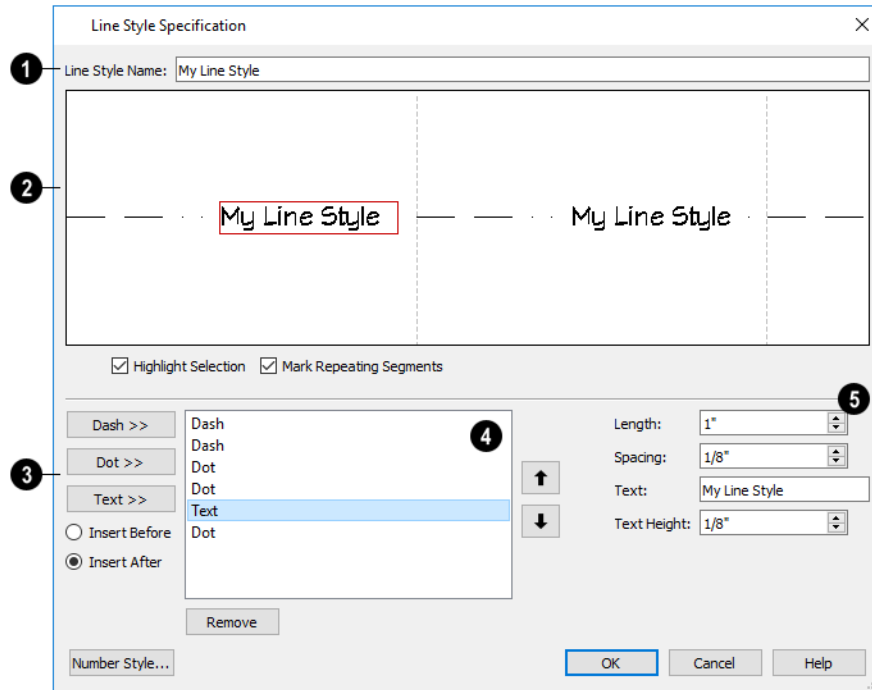

### 1 Line Style Name

Type the name of your **Line Style Name** in the text field. This is the name that will be listed in the Library Browser.

### 2 Line Style Preview

A preview diagram of the line style displays here.

- Click on a line style component in the preview to select it and edit it below.
- Check **Highlight Selection** to display a red rectangle around the currently selected line style component.
- Check **Mark Repeating Segments** to display vertical dashed lines indicating the division between the last component of one segment and the first component of the next in the preview diagram.

### 3 Line Style Components

These options allow you to add new components to your line style.

- Click the **Dash** button to add a line segment to the line style.
- Click the **Dot** button to add a single point to the line style.
- Click the **Text** button to add a section of text to the line style.
- Select the **Insert Before** radio button to add the new component before the component that is currently selected.
- Select the **Insert After** radio button to add the new component after the currently selected component.

### 4 Component Order

A list of the line style's individual components displays here.

- Click on the name of a component in the list to select it. When **Highlight Selection** is checked, above, a red rectangle displays around this component in the preview diagram.

- Click the **Up** arrow to move the selected component up one position in the list and one position to the left in the preview diagram.
- Click the **Down** arrow to move the selected component down one position in the list and one position to the right in the preview diagram.
- Click the **Remove** button to remove the selected component from the line style.

## 5 Component Specifications

Control the appearance of the selected component. The Length, Spacing, and Text Height values are all subject to the current Drawing Scale. See *Line Weights and Scaling on page 1375*.

- Specify the **Length** of a selected Dash or Text component when printed. If the Length exceeds that required by a Text component, empty space is added on each side of the text.
- Specify the **Spacing** of the selected component by defining the length of an empty space to the component's right.
- Type the **Text** of a selected Text component.
- Specify the **Text Height** of a selected Text component. Each text component can have its own height.

 Text inserted into a line style uses the font and transparency setting of the Text Style of the layer that it is on when assigned to an object. See *Text Styles on page 538*.

# Color Chooser/Select Color Dialog



The Color Chooser dialog is opened by selecting **Tools> Color Chooser**.

The similar Select Color dialog can be opened by clicking on the Color bar that can be found in many dialogs throughout the Windows version of the program.

 Mouse over a Color bar to display a tool tip reporting the selected color's RGB values.

In the Mac version, the standard Colors dialog, or Color Picker, is used instead.

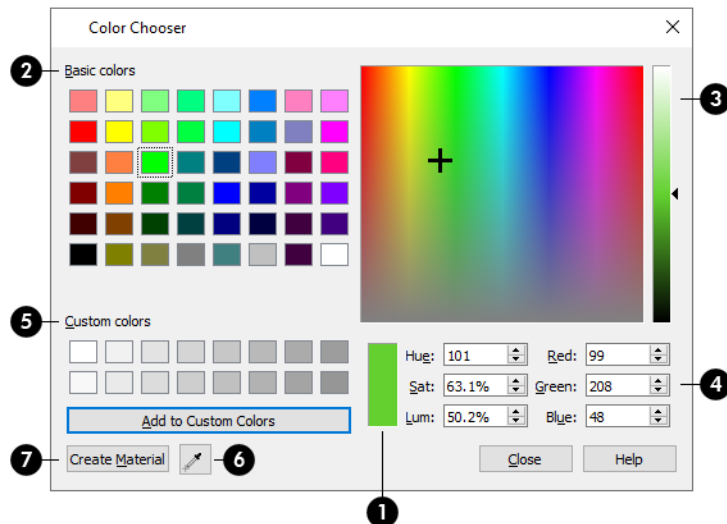

### 1 Current Color

The currently selected color displays in the rectangle at the lower center of the dialog. There are a number of ways to select a color in this dialog.

### 2 Basic Colors

Click in any one of the color boxes to select it.

### 3 Color Spectrum

- Click anywhere in the color spectrum area to select a color. The location of the selected color is identified by crosshairs.
- Click anywhere in the vertical bar or drag the arrow to adjust the selected color's Luminosity and RGB values.

### 4 Color Definition

- Define a color by specifying its **Hue**, **Saturation**, and **Luminosity** (HSL) or its **Red**, **Green**, and **Blue** (RGB) values.
- Specify the color's **Alpha channel** percentage, which is its degree of transparency. 100% is totally transparent. Only available when specifying a custom Toolbar Button/Image Background color for a Color Theme. See *Colors Panel on page 98*.
- Specify the color's **Opacity**. 0% is totally transparent. Only available when Selection and Edit Handle colors are being set via the COLORS panel of the Preferences dialog. See *Colors Panel on page 98*.

### 5 Custom Colors

- Click in one of the **Custom colors** boxes to either select it or to specify it as the box for a new custom color to be defined.
- Click the **Add to Custom Colors** button to add the selected color to the Custom Colors group.

### 6 Color Chooser Eyedropper

Click this button, then click anywhere on your monitor to select the color displaying at that location.

### 7 Create Material

Click this button to create a new material that uses the selected material as its Material Color. The new material is saved in the User Catalog of the Library Browser. See *The User Catalog on page 961*.

If the Select Color dialog was opened via another dialog panel, click OK to apply the currently selected color to the object's line or fill style, or to the material's pattern color.

# Editing Objects

## Chapter 9

Just as the methods used to create different objects in Chief Architect are similar, the options for moving, rotating, resizing, and otherwise editing them are also alike.

Edit handles allow objects to be resized, relocated, or rotated using the mouse. Edit toolbar buttons and the contextual menus access edit tools relevant to the selected object(s). Most objects have a specification dialog that allows you to edit it in ways that are specific to that type of object.

The editing characteristics common to most objects are described in this chapter. Unique, object-specific editing behaviors and the specification dialogs are covered in their respective chapters.

### TOPICS

<b>Defaults, Preferences, and Edit Behaviors</b> .....	<b>206</b>
<b>Selecting Objects</b> .....	<b>210</b>
<b>Selecting Multiple Objects</b> .....	<b>213</b>
<b>Editing Line-Based Objects</b> .....	<b>216</b>
<b>Editing Arc-Based Objects</b> .....	<b>219</b>
<b>Editing Open Polyline-Based Objects</b> .....	<b>224</b>
<b>Editing Closed Polyline-Based Objects</b> .....	<b>228</b>
<b>Editing Box-Based Objects</b> .....	<b>232</b>
<b>Editing Spline-Based Objects</b> .....	<b>235</b>
<b>Editing Circles, Ovals and Ellipses</b> .....	<b>239</b>
<b>Editing Multiple Objects</b> .....	<b>242</b>
<b>Moving Objects</b> .....	<b>243</b>
<b>Aligning Objects</b> .....	<b>246</b>
<b>Resizing Objects</b> .....	<b>253</b>
<b>Reshaping Objects</b> .....	<b>254</b>
<b>Rotating Objects</b> .....	<b>259</b>
<b>Reflecting Objects</b> .....	<b>261</b>
<b>Converting Objects</b> .....	<b>262</b>
<b>Transform/Replicate Object Dialog</b> .....	<b>266</b>
<b>Edit Area Tools</b> .....	<b>269</b>
<b>Stretch CAD</b> .....	<b>271</b>
<b>Trim and Extend</b> .....	<b>272</b>
<b>Union, Intersection, and Subtraction</b> .....	<b>274</b>
<b>Eyedropper and Painter Tools</b> .....	<b>277</b>
<b>Style Palettes</b> .....	<b>279</b>
<b>Matching Properties</b> .....	<b>282</b>
<b>Deleting Objects</b> .....	<b>284</b>
<b>Delete Objects Dialog</b> .....	<b>285</b>
<b>Undo and Redo</b> .....	<b>289</b>

## Defaults, Preferences, and Edit Behaviors

The same defaults and preference settings that affect how objects are drawn also influence how they can be edited. See [Defaults and Preferences on page 158](#).

 In addition, the **Edit Behavior** modes that determine how edit handles affect an object, and may also affect how objects are drawn. The currently active Edit Behavior is a global preference setting, affecting all plan and layout files.

Two of these modes, **Default** and **Alternate**, are useful for most drawing and editing needs and can be considered primary editing modes. Default mode, in particular, accesses the most commonly used behaviors and is the best choice in most circumstances.

When an Edit Behavior other than Default is active, its icon displays near the mouse pointer. For example, when **Connect CAD Segments** is disabled, CAD objects cannot connect to form polylines and the Connect CAD Segments  icon follows the mouse pointer to remind you that this behavior is active. See [Pointer Icons on page 16](#).

Regardless of which Edit Behavior is active, the Default behavior is restored when you close the program.

The other modes, **Move**, **Resize**, **Concentric**, and **Fillet**, offer special editing behaviors that may be useful only in certain situations and can be considered secondary.

Each edit behavior can be temporarily enabled using the different buttons on your mouse or by pressing the keyboard keys associated with each. See [Using Input Devices on page 14](#) and [Hotkeys on page 137](#).

You can also specify which edit behavior mode is active when the left mouse button is used in the Preferences dialog, by selecting **Edit> Edit Behaviors** , or by clicking the corresponding toggle button, which can be added to your toolbar.

See [Behaviors Panel on page 118](#).

### DEFAULT

 The **Default** mode is one of the primary edit behavior modes. It offers access to the most commonly used edit behaviors and should be selected as your preference in most situations.

 When the use of a tool is described in this manual, it is assumed that the Default edit behavior mode is active.

- **Drawing** - Standard click and drag drawing behavior is enabled. See [Creating Objects on page 164](#).
- **Resize/Reshape** - Default allows you to adjust the angle of any corner of a polyline without affecting adjacent corners, changing the object's shape.

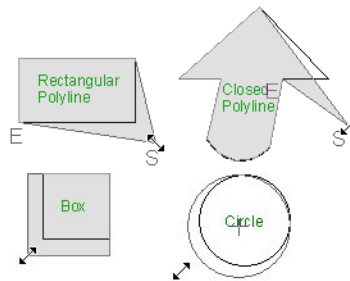

- For box-based objects, the Default mode functions the same as the Alternate mode.

- **Movement** - Default allows you to move objects orthogonal, or at a right angle, to any of their edges.
- **Rotation** - In Default mode, objects snap at Allowed Angles as they are rotated.

You can temporarily enable the **Default**  edit mode when another mode is active by pressing **Alt + Z** or **Alt + /** while performing an edit or drawing operation.



## ALTERNATE

**Alt** The **Alternate** mode is the second primary edit behavior mode. When this mode is active, the Alternate Alt icon displays near the mouse pointer.

Note: Not all commands have an Alternate edit behavior. If a selected tool does not, it will not work when this edit mode is active.

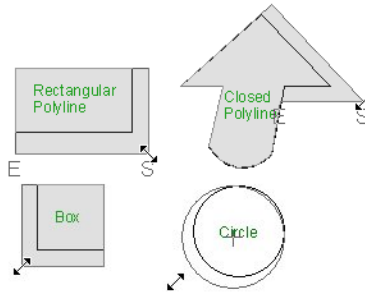

- **Drawing** - Continuous drawing behavior is enabled. See *Clicking and Dragging on page 165*.
- **Resize/Reshape** - Alternate allows you to keep the angle between adjacent edges fixed when a corner edit handle is moved. Instead, adjacent corners move and adjacent edges lengthen or shorten.



- Alternate allows you to drag an end handle on an open polyline to change it from a line to an arc or vice versa.
- Alternate overrides the **Lock Center**  setting of arc-based objects.
- **Movement** - Alternate allows you to move objects at Allowed Angles when **Angle Snaps**  are enabled, or orthogonal to any of its edges when they are not. See *Angle Snaps on page 162*.
- **Rotation** - Alternate snaps objects at Allowed Angles as they are rotated.

You can temporarily enable the **Alternate** edit mode when another mode is active by pressing **Alt** or using the right mouse button while performing an edit or drawing operation.



## MOVE

 The **Move** mode allows you to move an object using edit handles that would otherwise be used for resizing, as well as with the Move handle. When this mode is active, the Move  icon displays near the mouse pointer.

- **Drawing** - Standard click and drag drawing behavior is enabled.
- **Resize/Reshape** - Move allows you to move the selected object when any edit handle is used.
- **Movement** - Move mode allows you to move objects at Allowed Angles.
- **Rotation** - In Move mode, objects snap at Allowed Angles as they are rotated.

You can temporarily enable the **Move** edit mode when another mode is active by pressing **Z** or **/** while performing an edit or drawing operation.

## RESIZE

 The **Resize** edit behavior allows you to rescale an object. As you drag a corner edit handle of an object, you get an exactly scaled version of the original. For example, you can resize an object to 50% of its original size while maintaining the same proportions. When this mode is active, the **Resize**  icon displays near the mouse pointer.

- **Drawing** - Standard click and drag drawing behavior is enabled.
- **Resize/Reshape** - Resize allows you to keep the angle between adjacent edges fixed when a corner handle is moved.

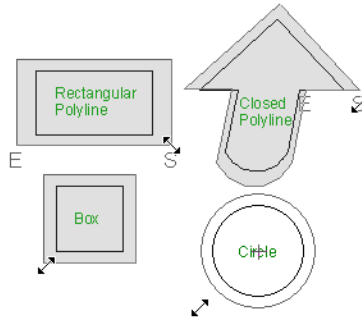



To proportionally resize an object, always drag a corner edit handle and not an edge handle.

- **Movement** - Resize allows you to move an object orthogonal, or at a right angle, to any of its edges.
- **Rotation** - In Resize Mode, objects snap at Allowed Angles as they are rotated.

You can temporarily enable the **Resize** edit mode when another mode is active by pressing **X** or the period key, or using the X2 button on a five-button mouse while performing an edit or drawing operation. See [Using Input Devices on page 14](#).

## CONCENTRIC

 The **Concentric** mode allows you to resize objects so that the distance moved by each edge is the same. For example, you can resize an irregularly shaped polyline so that each edge is exactly ten feet in from the original position, which is useful for creating site plans with setbacks. When this mode is active, the Concentric  icon displays near the mouse pointer.

- **Drawing** - Standard click and drag drawing behavior is enabled.
- **Resize/Reshape** - Concentric allows you to resize an irregularly-shaped polyline so that each edge is moved the same distance from its original location.

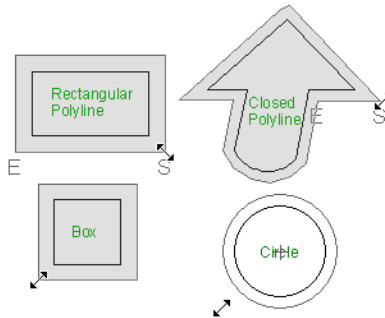

- Concentric mode also allows you to move opposite edges of an object so that each edge is moved the same distance from its original location.



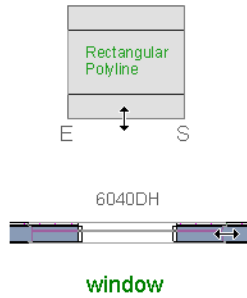

- **Movement** - Concentric mode allows you to move an object orthogonal, or at a right angle, to any of its edges.
- **Rotation** - In Concentric mode, objects snap at Allowed Angles as they are rotated.

In some cases, the Concentric and Resize edit behaviors have the same result, such as when a circle is resized. Usually, though, the two behaviors are different because concentric resizing does not maintain the original ratio between an irregular polyline’s edges.

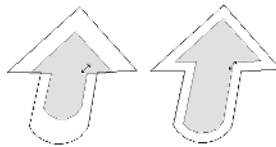

In Concentric mode, objects resize in **Concentric Jump** increments specified in the Preferences dialog. See [Behaviors Panel on page 118](#).

When the **Concentric Jump** distance is set at 0", objects resize according to the **Snap Unit** specified in the Plan Defaults dialog. See [Grid Snaps on page 163](#).

To concentrically resize an object with no restrictions, set the Concentric Jump value on the Behaviors panel of the Preferences dialog to zero and turn off Grid Snaps.

You can temporarily enable the **Concentric** edit mode when another mode is active by pressing **C** or the command key, or using the X1 button on a five-button mouse while performing an edit or drawing operation. See [Using Input Devices on page 14](#).

## FILLET

The **Fillet** mode allows you to add a fillet, or curve, at any corner of an object. Dragging a corner edit handle adjusts the fillet radius at that corner. When this mode is active, the Fillet icon displays near the mouse pointer.

- **Drawing** - Standard click and drag drawing behavior is enabled.
- **Resize/Reshape** - Fillet allows you to create a fillet at by dragging a corner edit handle inward.

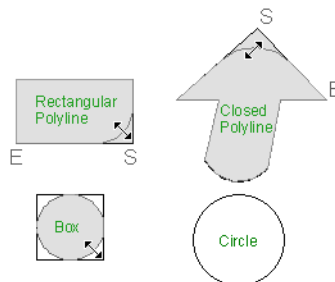

- **Movement** - Move mode allows you to move objects at Allowed Angles.
- **Rotation** - In Move mode, objects snap at Allowed Angles as they are rotated.

The **Fillet** edit behavior adjusts all the corners of a box at once. The radius of each corner is the same.

**Fillet** does not have an effect on circles, ovals, ellipses or arc segments.

You can temporarily enable the **Fillet** edit mode when another mode is active by pressing **F** while performing an edit or drawing operation.

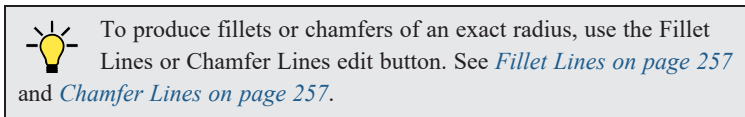

## CONNECT CAD SEGMENTS



 Typically, when two CAD objects share the same properties and Endpoint Snaps are enabled, they can be snapped end-to-end to form a polyline. **Connect CAD Segments** controls whether CAD objects with the same properties can be snapped together to form polylines. It also controls whether spline segments can be snapped together. See [Polylines on page 316](#) and [Splines on page 324](#).

Select **Edit > Edit Behaviors > Connect CAD Segments** to toggle this behavior on or off. You can also turn **Connect CAD Segments** on or off in the Preferences dialog. See [CAD Panel on page 114](#).

In addition to CAD objects, **Connect CAD Segments** also affects stairs, ramps, and road objects. See [Stairs, Ramps, and Landings on page 742](#) and [Roads, Driveways, and Sidewalks on page 1283](#).

When **Connect CAD Segments** is disabled, CAD objects cannot connect to form polylines and the Connect CAD Segments  icon displays near the mouse pointer. See [Pointer Icons on page 16](#).

## ROTATE/RESIZE ABOUT CURRENT POINT

 Objects can be rotated or resized about either their own centers or the current CAD point. See [The Current Point on page 298](#). When this mode is active, the **Rotate/Resize About Current Point**  icon displays near the mouse pointer. See [Rotate/Resize About on page 259](#).

---

# Selecting Objects

“Select” refers to selecting an object for editing. An object must be selected before it can be edited. There are a number of ways that objects can be selected:

In order for an object to be selected, it must be both unlocked and visible in the current view. See [Layers on page 176](#).

When an object is selected, it displays edit handles and a selection fill color. See [Colors Panel on page 98](#).

In 3D views, a selected object will also display lines representing the selected edge or surface. The size of the edit handles does not change as you zoom in or out and is set in the Preferences dialog. See [Edit Panel on page 115](#). To prevent them from stacking on one another, some edit handles may not display as you zoom away from the selected object.

When an object is selected, its edit toolbar also displays, typically at the bottom of the Chief Architect program window just above the Status Bar. See [The Edit Toolbar on page 130](#).





Groups of objects can also be selected simultaneously. See [Selecting Multiple Objects on page 213](#).

Information about the selected object or objects will also display in the Status Bar. See *The Status Bar on page 24*.

A selected object remains selected until another object is selected, a different tool is activated, the Esc key on the keyboard is pressed, or any two mouse buttons are pressed at the same time.

## FINDING OBJECTS

In order to select an object for editing, you may first need to find it. There are a variety of tools in the program designed to help you locate specific objects. These tools often open a new view window in which the object in question is either highlighted or selected.

- To find out where a line item in a schedule or the Materials List is located in the model, select its row or any cell in its row and click the **Find Object in Plan**  edit button. See *Find Object in Plan on page 691*.
- To locate a string of text, select **Edit> Find/Replace Text**. See *Find/Replace Text on page 516*.
- To find objects that are similar to a selected object in the current view, click the **Match Properties**  edit button. See *Matching Properties on page 282*.
- In a Wall Detail, Framing Overview or other 3D view in which wall framing can be seen, select a wall framing member and click the **Find Wall**  edit button to locate its owner wall in plan view. See *Selecting Walls on page 368*.
- In the Truss Detail, select a truss and click the **Find Trusses**  edit button to switch to a plan view in which the truss is selected. See *Truss Details on page 901*.
- In the Project Browser, right-click on a schedule or Layout Table and select **Find in Project** from the contextual menu. The view in which the schedule is located opens, if necessary, and the schedule or table is selected. See *Project Browser on page 58*.

Additional tools are available to help you find files referenced by your plans and layout files.

- Select **Tools> Checks> Missing Files Check** to identify and locate any missing referenced files. See *Linked and Referenced Files on page 51*.
- Select **Tools> Layout> Referenced Plan Files** to identify and locate any plans linked to the current layout file. See *Managing Layout Links on page 1353*.

## SELECT OBJECTS

 With the exception of temporary CAD points, any object created using Chief Architect Premier's drawing tools can be selected using the **Select Objects** tool. Select **Edit> Select Objects**, click the toolbar button or press the **Space** bar on your keyboard to activate this tool, then click on an object or its label to select it. See *Object Labels on page 699*.



You can also select objects or open context sensitive menus using the right mouse button when any tool is active.

By default, you can select an object by clicking within 12 pixels of it. You can adjust this distance by changing the **Snap Distance** in the Preferences dialog. A lower value, for example, can be helpful for working with small objects but can also make it very difficult to select larger objects. See *Snap Properties Panel on page 119*.

## SELECT NEXT OBJECT

 If there is more than one object in a particular space, it may be difficult to select the desired object. When a nearby object is selected, click the **Select Next Object** edit button or press the Tab key until the desired object becomes selected. This function cannot be applied to groups of selected objects.

## SELECTING SIMILAR OBJECTS

If a tool other than **Select Objects**  is active, you can only select objects of that type using the left mouse button. For example, if the **Straight Exterior Wall**  tool is active, you can only select walls using the left mouse button.

This can be useful for selecting an object when many objects of a different type occupy the same space in plan view.

Objects can be selected using the right mouse button, regardless of which tool is active.

## RIGHT-CLICKING

Regardless of which tool is active, you can select an object by right-clicking on it once. When you right-click to select an object a contextual menu also appears, displaying the object's edit tools. You can turn contextual menus on or off in the Preferences dialog. See [Contextual Menus on page 19](#).

If a drawing tool is active and you right-click to select an object, you can unselect it by left-clicking in an empty space in the drawing area. Although a drawing tool is active, it is not used. If you then left-click a second time, the active tool will be used.

## SELECTED EDGE

When you click on a polyline- or box-based object, the edge that you click nearest becomes the selected edge and displays an edit handle larger and of a different color than those on other edges. The handle on this edge may also display at the point where you clicked to select it. You can specify the **Selected Edge Handle Fill** color in the Preferences dialog. See [Colors Panel on page 98](#).

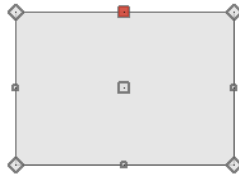

This edge can be edited on the **SELECTED LINE** or **SELECTED ARC** panel of the object's specification dialog, as well as using a variety of edit toolbar buttons. It can also be moved using dimensions. See [Moving Objects Using Dimensions on page 483](#), [Line Panel on page 304](#) and [Arc Panel on page 312](#).

The Start and End points of a CAD-based object's selected edge or of a wall can be indicated by an S and an E when the object is selected. These Start and End indicators can be helpful when editing the selected edge in the object's specification dialog, and their display can be turned on and off in the Preferences dialog. See [Edit Panel on page 115](#).



## DISCONNECT EDGES



 Polyline-based objects are composed of lines and arcs that are connected end to end. The individual edges of open and closed polylines can be selected and edited independently of the object's other edges when **Disconnect Edges** is in use. Select **CAD> Lines> Disconnect Edges** to enable this ability.

**Disconnect Edges** also affects terrain paths and molding polylines, but does not affect Walkthrough Paths, Connect Electrical or Sprinkler splines, or closed polyline-based objects such as slabs and roof planes.

### To use *Disconnect Edges*

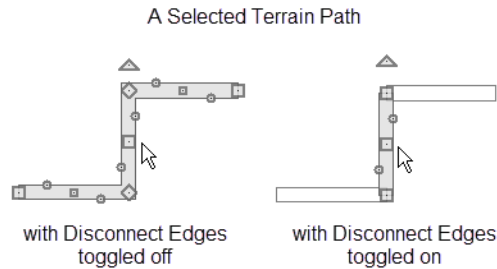
1. Select **CAD> Lines> Disconnect Edges** .
2. Click on an individual edge of an eligible polyline-based object to select it.



3. Notice that it is no longer connected to the rest of the polyline.
4. The individual segment can now be edited entirely independent of its neighbors.
5. Continue clicking on polyline edges to disconnect them from their polyline.
6. When you are finished, click the **Select Objects**  button or activate another tool.
7. To connect the segment to the polyline again, move the end handles so that they snap to the ends of adjacent segments.
8. When **Disconnect Edges**  is used, only edges that you click on are actually affected by it. Any polylines that you do not click on will remain intact.

You can also separate the selected edge of an open or closed polyline from the rest of the polyline by clicking the **Disconnect Selected Edge**  edit button. See [Selected Edge on page 212](#).

### SELECTED SIDE

Most architectural objects can be selected in 3D views. When selected, the outline of their bounding box displays, and edit handles are located on the side where you clicked to select the object. The edit handles can be used to move, resize, or rotate the object in different directions, depending on which side is selected. Depending on which side is selected, the available edit handles may vary, as well.



If the currently selected side of an object is not the one you need, click the **Select Next Side** edit button to select a different side of the object. You can cycle through all sides of the object until the one you need is selected.

---

## Selecting Multiple Objects

Multiple objects can be selected and edited in groups. The options available for editing them will vary depending on the type or types of objects selected. See [Editing Multiple Objects on page 242](#).

### MARQUEE SELECT

Groups of objects can be selected by holding down either the Shift or Ctrl key when the **Select Objects**  tool is active and then dragging a marquee around the objects to be selected.

When using the marquee-select method, both CAD and architectural objects included in the marquee are selected. To remove an object from the selection set, hold down the Ctrl key and click on it.

If an object is selected and a selection marquee is drawn around it using the Ctrl key, that object becomes deselected. If the Shift key is used instead, the original object remains selected and the other objects are added to the selection set.

The Shift key can be used to marquee-select objects of a similar type when the drawing tool used to create those objects is active.

### ***To marquee-select objects by type***

1. Select a drawing tool used to create the type of object you wish to select: for example, the **Hinged Door**  tool.
2. Hold down the Shift key, then click and drag a rectangular selection marquee in the drawing area.
3. When you release the mouse button, objects of the selected drawing tool's type - here, door objects - located in the marquee will be selected.







You can specify whether objects must be totally contained in or intersected by the marquee, or whether an object's center point must be contained in the marquee, in the Preferences dialog or using the **Selection Mode**  buttons, which can be added to your toolbars. See [Edit Panel on page 115](#).

 To make marquee selection easier, you can turn off the display of objects you do not want to include in your selection set. See [Layers on page 176](#).

## **MARQUEE SELECT SIMILAR**

 The **Marquee Select Similar** edit tool lets you group-select objects in the current plan view or CAD Detail that are similar to the selected object(s).

### ***To use Marquee Select Similar***

1. In plan view, select one or more objects, then click the **Marquee Select Similar**  edit button.
2. The **Restrictive Selection**  toggle controls whether objects are selected by similar type(s) only, or if additional attributes are taken into account.
  - **Restrictive Selection**  is disabled by default, so objects of the same type will be selected.
  - Click the **Restrictive Selection**  edit button to toggle it on and select only objects with additional attributes like materials or layer in common.
3. Click and drag a rectangular selection marquee in the drawing area to select similar objects within its area.
4. Alternatively, click the **Select All Similar**  edit button to select all similar objects in the current view.
5. The **Marquee Select Similar**  tool is not available for all object types in all views. For example, it is not available for wall framing in plan view, although it is in Wall Detail views.

## **SHIFT AND CTRL SELECT**

You can select a group of objects by adding them to the selection set one by one. Select an object, hold down either the Shift or Ctrl key, and click additional objects to select them.

More than one type of object can be selected using this method, but the ability to edit the group-selected items is limited to attributes that all selected objects have in common.

To remove an object from a selection set, click on it once more with the Ctrl key pressed.

The Shift and Ctrl keys can be used to select multiple items in a variety of contexts, such as: the and Project Browsers, lists in dialog boxes, and files to be imported. They can also be used to marquee-select objects in plan view. See [Marquee Select on page 213](#), above.

## SELECT ALL

Select **Edit> Select All** to select all objects drawn on the current floor, in the current cross section/elevation view or CAD Detail window, or on the current layout page.

## EDIT AREA

 The **Edit Area Tools** allow you to define an area of your plan and select the objects within that area for editing. See [Edit Area Tools on page 269](#).

## USING A FENCE

 The **Fence Select** edit tool allows you to group-select multiple CAD and CAD-based objects in contact with the selected CAD line, arc, polyline or spline.

Using a Fence to make a group-selection can be helpful in a number of situations, for example:

- When many CAD objects must be selected, particularly when they occupy the same area.
- When a selection marquee would be the wrong shape or include too many objects.
- When a selection group needs to be selected more than once.

The **Fence Select**  edit tool cannot be used to select architectural objects - only CAD and CAD-based objects. See [Architectural vs CAD Objects on page 158](#).

Fences are often used with the **Trim Objects**  and **Extend Objects**  edit tools. See [Trim and Extend on page 272](#).

### ***To Fence Select a group of objects***

1. Draw a CAD line, arc, open polyline, closed polyline or spline that crosses or touches all the objects you wish to group-select.
2. Click the **Fence Select**  edit button.
3. The originally selected object serves as a fence to select the objects it touches, while becoming deselected itself.
4. You can hold either the Shift or Ctrl key and click objects to add or remove them from the selection set.



You can keep all fences on their own custom layer and turn off their display when not needed. See [Layers on page 176](#).

## MATCH PROPERTIES

 Rooms, cabinets, windows and doors on the current floor can be selected based on a set of attributes that you specify using the **Match Properties** edit tool. See [Match Properties on page 282](#).

## Editing Line-Based Objects

Objects are considered line-based when they can be edited similar to CAD lines using their edit handles.

CAD lines, framing members, straight walls and railings, straight stairs, and straight roads are examples of line-based objects.

Most line-based objects can be connected to the ends of other like objects to form polylines or polyline-based objects provided that they are on the same layer and have identical attributes such as line color and arrow specifications. See [Editing Open Polyline-Based Objects on page 224](#) and [Editing Closed Polyline-Based Objects on page 228](#).

Some objects, notably walls, have line-based editing behavior only when selected on certain surfaces. See [Editing Walls on page 368](#).

Wall openings such as doors and windows have line-based editing behavior in plan view only but cannot be rotated, reversed or converted to an arc. See [Editing Doors on page 551](#) and [Editing Windows on page 588](#).

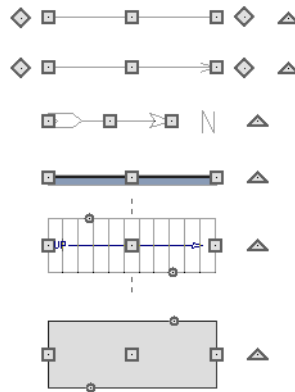

Other objects, such as stairs, foundation walls with footings, and roads, have additional edit handles that allow you to concentrically adjust the object's width.

### USING THE EDIT HANDLES

When selected, a typical line-based object displays six edit handles: a Move handle, two Extend/Change Angle handles, two Same Line Type handles, and a Rotate handle.

Any action performed using the edit handles can be canceled by pressing the Esc key or any two mouse buttons at the same time.



The behavior of the edit handles may depend on the currently active Edit Behavior. See [Defaults, Preferences, and Edit Behaviors on page 206](#).

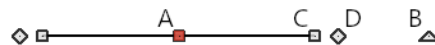

#### A. Move

- Click and drag the Move handle to move the object according to the currently active **Edit Behavior** . See [Defaults, Preferences, and Edit Behaviors on page 206](#).
- Movement may be limited or stopped by other objects or Snap Behaviors. Move restrictions can be overridden by holding down the Ctrl key while dragging. See [Unrestricted Movement on page 244](#).



### B. Rotate

- The **Rotate** handle is used to rotate the object, either about its center or about the current CAD point. See [Rotating Objects on page 259](#).

### C. Extend/Change Angle

- Drag a square end handle parallel to the selected line to change its length.
- Drag a square end handle at an angle to the selected line to change its angle. When **Angle Snaps**  are on, the line snaps to Allowed Angles. See [Angle Snaps on page 162](#).
- Right-click and drag it to change the adjacent line into an arc, or vice versa. See [Alternate on page 207](#).

### D. Same Line Type

- Drag a diamond-shaped end handle in any direction to draw a new line that shares the original's color, weight, line style, and layer. See [Same Line Type Edit Handles on page 303](#).

### Adjust Width

Some line-based objects, such as stairs and roads, have additional handles that allow the width of the object to be adjusted.

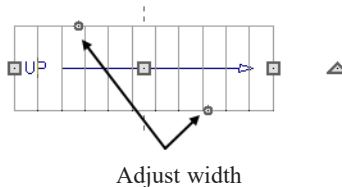

- Click and drag a small, round **Expand** handle to increase or decrease the object's width. By default, objects are resized in 1" increments. This Snap Unit is defined in the Plan Defaults dialog. See [General Plan Defaults Dialog on page 92](#).

## USING DIMENSIONS

-  Dimensions can be used to position line-based objects relative to other objects. See [Moving Objects Using Dimensions on page 483](#).

Dimensions cannot, however, be used to adjust the length of line-based objects, or the width of line-based objects such as stairs.

## USING EXTENSION LINE SNAPS

Extension line snaps can be useful when editing line-based objects. See [Extension Snaps on page 161](#).

## USING THE SPECIFICATION DIALOG

-  Line-based objects can be edited using their specification dialogs. See [Line Specification Dialog on page 304](#).

## USING THE EDIT TOOLBAR

A selected line-based object can be edited in a variety of ways using the buttons on the Edit Toolbar.

The following toolbar buttons may display on the Edit Toolbar for a selected line-based object:



**Select Next Object** selects nearby objects instead of the selected object. See [Selecting Objects on page 210](#).



**Open Object** opens the specification dialog for the selected object(s). See [Specification Dialogs on page 21](#).



**Copy/Paste** copies the selected object(s) to the system clipboard so they can be pasted elsewhere. See *Copying and Pasting Objects on page 167*.



**Delete** deletes the selected object(s). See *Deleting Objects on page 284*.



**Transform/Replicate Object** copies, moves, rotates, resizes, or reflects the selected object(s). See *Transform/Replicate Object Dialog on page 266*.



**Multiple Copy** make a series of copies at set intervals. See *Multiple Copy on page 172*.



**Make Parallel/Perpendicular** makes the selected object(s) parallel or perpendicular to a straight edge. See *Make Parallel/Perpendicular on page 250*.



**Point to Point Move** accurately moves the selected object(s). See *Point to Point Move on page 245*.



**Center Object** centers an object along a wall within a room or relative to a cabinet fixture. See *Center Object on page 250*.



**Reflect About Object** reflects the selected object(s) about another object. See *Reflecting Objects on page 261*.



**View Drawing Group Edit Tools** modifies the selected object's place in the drawing order. See *Drawing Group Edit Tools on page 190*.



**Add Break** adds a new corner or pivot point to the selected object. See *Add Break on page 254*.



**Complete Break** breaks the selected object into two separate objects. See *Add Break on page 254*.



**Reverse Direction** reverses the direction of the selected object(s). See *Reverse Direction on page 262*.



**Convert Polyline** converts the object into a special polyline-based object. See *Convert Polyline on page 262*.



**Revision Cloud(s) Around Objects** creates a revision cloud around each of the selected object(s). See *Revision Clouds on page 321*.



**Change Line/Arc** changes a line-based object to an arc, or vice versa. See *Change Line/Arc on page 256*.



**Fence Select** uses the selected object(s) as a selection fence. See *Using a Fence on page 215*.



**Object Layer Properties** accesses and edits layer information about the selected object. See *Object Layer Properties on page 187*.



**Intersect/Join Two Lines** joins two non-parallel lines or arcs. See *Intersect/Join Two Lines on page 256*.



**Fillet Lines** create an additional arc connecting two non-parallel lines or arcs. See *Fillet Lines on page 257*.



**Chamfer Lines** chamfers the corner between adjacent edges. See *Chamfer Lines on page 257*.



**Extend Object(s)** lengthens other object(s) until they intersect the selected object. See *Trim and Extend on page 272*.

Not available for Sun Angles or North Pointers.



**Trim Object(s)** shortens the length of object(s) intersected by the selected object. See *Trim and Extend on page 272*.

Not available for Sun Angles or North Pointers.



**Align/Distribute Objects** specifies how the selected objects are distributed. See *Align/Distribute Objects on page 246*.

Only available when multiple objects are selected.



**Align/Distribute Along Line** aligns the selected object(s) relative to another line. See [Align/Distribute Along Line on page 248](#).



**Set as Default** allows you to apply the settings in a selected object's specification dialog to the defaults for that type of object. Available for Construction Lines and various line-based architectural objects but not standard CAD objects. See [Set as Default on page 79](#).

## Editing Arc-Based Objects

Objects are considered arc-based when they can be edited similar to CAD arcs using their edit handles.

CAD arcs, curved walls and railings, curved stairs, and curved roads are examples of arc-based objects.

Most arc-based objects can be connected to other like objects to form polylines or polyline-based objects provided that they are on the same layer and have identical attributes such as line color and arrow specifications. See [Editing Open Polyline-Based Objects on page 224](#) and [Editing Closed Polyline-Based Objects on page 228](#).

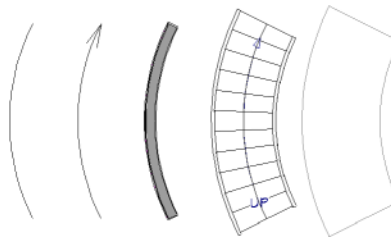

Some objects, notably curved walls, have arc-based editing behavior only when selected on certain surfaces. See [Editing Walls on page 368](#).

Other objects, such as curved stairs and roads, have additional edit handles that allow you to concentrically adjust the object's width.

The currently active **Arc Creation Mode**  determines how an arc-based object is drawn. Once an arc is drawn, the active Arc Creation Mode does not affect it. See [Drawing Arcs - Arc Creation Modes on page 307](#).

### USING THE EDIT HANDLES

When selected, a typical arc-based object displays seven edit handles.

Any action performed using the edit handles can be canceled by pressing the Esc key or any two mouse buttons at the same time.

 The behavior of the edit handles may depend on the currently active Edit Behavior. See [Defaults, Preferences, and Edit Behaviors on page 206](#).

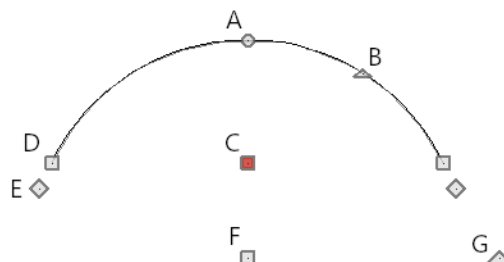

- A. Resize (changes radius)
- B. Reshape (moves center)

- C. Move Chord
- D. Extend (along arc or chord)
- E. Same Line Type
- F. Move Arc Center
- G. Rotate

### Move

- Two Move edit handles allow the arc to be relocated without changing its shape. One is located at the center of the chord and the other, at the arc center.
- If you would like to snap one of these center points to another point, use that handle when moving the arc. See [Aligning Arc Centers on page 253](#).
- Click and drag the Move handle to move the object according to the currently active **Edit Behavior** . See [Defaults, Preferences, and Edit Behaviors on page 206](#).
- Movement may be limited or stopped by other objects or Snap Behaviors. Move restrictions can be overridden by holding down the Ctrl key while dragging. See [Unrestricted Movement on page 244](#).

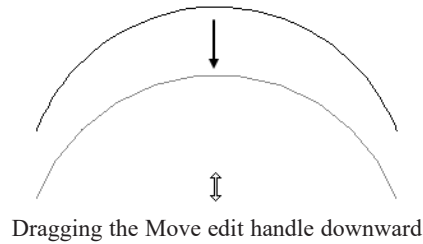

### Rotate

- The **Rotate** handle is used to rotate the arc, either about its center or about the current CAD point. See [Rotating Objects on page 259](#).

### Extend

- The end edit handles expand or contract the arc when moved along the arc radius or chord.
- If you follow the path of the arc, the end edit handles allow you to adjust the arc length.
- The angle formed by the center point of the arc and its two endpoints is referred to as the Included Angle. If **Angle Snaps** are on, the Included Angle of the arc, as measured in degrees, can be rotated at Allowed Angles. See [Angle Snaps on page 162](#).
- Right-click and drag it to change the adjacent arc into a line, or vice versa. See [Alternate on page 207](#).

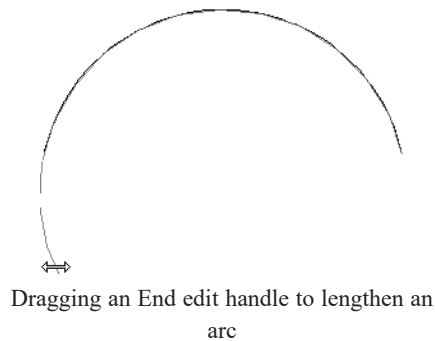

### Resize

- Drag the small, round **Resize** edit handle to change the radius and included angle of the arc while maintaining its center.

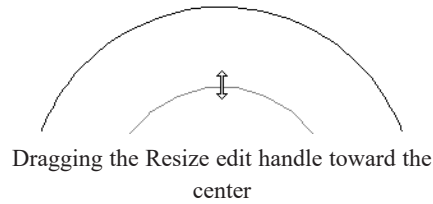

### Reshape

- Drag the small triangular **Reshape** handle to change the length and location of the center without moving the endpoints.

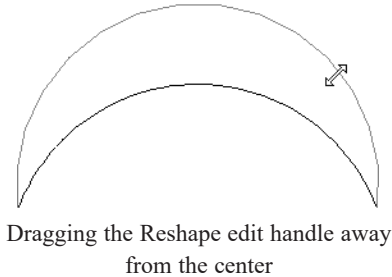

- If the object has a locked center, the **Reshape** edit handle does not display. See [Lock Center on page 223](#).

### Same Line Type

- Drag a diamond-shaped end handle in any direction to draw a new line that shares the arc's color, weight, line style, and layer. See [Same Line Type Edit Handles on page 303](#).

### Adjust Width

Some arc-based objects, such as stairs, have additional handles that allow the width of the object to be adjusted.

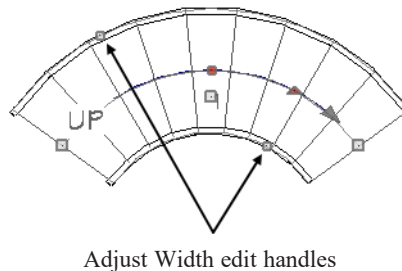

- Click and drag a small, round edit handle to increase or decrease the object's width. By default, objects are resized according to the Snap Unit defined in the Plan Defaults dialog. See [General Plan Defaults Dialog on page 92](#).

## USING DIMENSIONS

 Dimensions can be used to position arc-based objects. Dimension lines typically locate tangent extension lines and any extension lines that may be parallel to those lines rather than the arc itself. See [Moving Objects Using Dimensions on page 483](#).

## USING EXTENSION LINE SNAPS

Extension line snaps can be useful when editing arc-based objects. See [Extension Snaps on page 161](#).

## USING THE SPECIFICATION DIALOG

 Arc-based objects can be edited using their specification dialogs. See *Arc Specification Dialog on page 311*.

## USING THE EDIT TOOLBAR

A selected arc-based object can be edited in a variety of ways using the buttons on the Edit Toolbar.

The following toolbar buttons may display on the Edit Toolbar for a selected arc-based object:



**Select Next Object** selects nearby objects instead of the selected object. See *Selecting Objects on page 210*.



**Open Object** opens the specification dialog for the selected object(s). See *Specification Dialogs on page 21*.



**Copy/Paste** copies the selected object(s) to the system clipboard so they can be pasted elsewhere. See *Copying and Pasting Objects on page 167*.



**Delete** deletes the selected object(s). See *Deleting Objects on page 284*.



**Transform/Replicate Object** copies, moves, rotates, resizes, or reflects the selected object(s). See *Transform/Replicate Object Dialog on page 266*.



**Multiple Copy** makes a series of copies at set intervals. See *Multiple Copy on page 172*.



**Point to Point Move** accurately moves the selected object(s). See *Point to Point Move on page 245*.



**Center Object** centers an object along a wall within a room or relative to a cabinet fixture. See *Center Object on page 250*.



**Reflect About Object** reflects the selected object(s) about another object. See *Reflecting Objects on page 261*.



**View Drawing Group Edit Tools** modifies the selected object's place in the drawing order. See *Drawing Group Edit Tools on page 190*.



**Add Break** adds a new corner or pivot point to the selected object. See *Add Break on page 254*.



**Complete Break** breaks the selected object into two separate objects. See *Add Break on page 254*.



**Reverse Direction** reverses the direction of the selected object(s). See *Reverse Direction on page 262*.



**Convert Polyline** converts the object into a special polyline-based object. See *Convert Polyline on page 262*.



**Revision Cloud(s) Around Objects** creates a revision cloud around each of the selected object(s). See *Revision Clouds on page 321*.



**Change Line/Arc** changes an arc-based object to a line, or vice versa. See *Change Line/Arc on page 256*.



**Convert Curve to Polyline** converts the selected arc into a polyline. See *Convert Curve to Polyline on page 258*.



**Lock Center** locks the selected arc-based object's center. See *Lock Center on page 223*.



**Make Arc Tangent** adjusts the arc and attached line(s) so they transition smoothly. See *Make Arc Tangent on page 252*. Only available when a selected arc is attached on one or both ends to another line or arc.



**Fence Select** uses the selected object(s) as a selection fence. See [Using a Fence on page 215](#).



**Object Layer Properties** accesses layer information about the selected object. See [Object Layer Properties on page 187](#).



**Intersect/Join Two Lines** joins two non-parallel lines or arcs. See [Intersect/Join Two Lines on page 256](#).



**Fillet Lines** creates an additional arc connecting two lines. See [Fillet Lines on page 257](#).



**Chamfer Lines** creates an additional edge connecting two lines. See [Chamfer Lines on page 257](#).



**Extend Object(s)** lengthens other object(s) until they intersect the selected object. See [Trim and Extend on page 272](#).



**Trim Object(s)** shortens the length of object(s) intersected by the selected object. See [Trim and Extend on page 272](#).



**Align/Distribute Objects** specifies how the selected objects are distributed. See [Align/Distribute Objects on page 246](#). Only available when multiple objects are selected.



**Align/Distribute Along Line** aligns the selected object(s) relative to a line-based object. See [Align/Distribute Along Line on page 248](#).

## ARC CENTERS AND ENDS

 When working with arc-based objects or circles, it can be helpful to see their center points. Similarly, when snapping arcs together to form a polyline, seeing their endpoints can be helpful. Select **View > Arc Centers and Ends** to toggle the display of both on the current floor. You can also turn on their display in the CAD Defaults dialog. See [CAD Defaults Dialog on page 291](#).

Arc-based objects can be aligned using their center points. See [Aligning Arc Centers on page 253](#).

## LOCK CENTER



Click the **Lock Center** edit button to lock or unlock the selected arc-based object's center. When an arc's center is locked, it cannot be moved except by using one of its Move edit handles or when the **Alternate** **Alt** edit behavior is enabled.

An arc-based object with a locked center lengthens and shortens along its curve when it is resized. When this is not possible, its radius changes. In either case, its center remains locked in the same place.

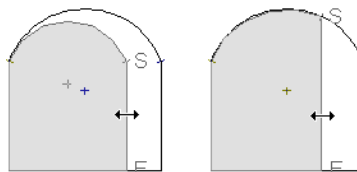

Resizing with center unlocked vs with center locked

Locked-center arcs do not display a **Reshape** edit handle when selected. See [Using the Edit Handles on page 219](#).

When it is part of a polyline, a locked-center arc resizes along its arc rather than its chord when an adjacent line or arc is moved. Thus, the radius remains constant for an unlocked center arc, while the center does not change for a locked-center arc.

## Editing Open Polyline-Based Objects

Open polyline-based objects are composed of individual line- and arc-based objects that are connected at their end points but do not form an enclosed area. See [Polylines on page 316](#).

Objects are considered open polyline-based when they can be edited similar to open CAD polylines using their edit handles.

Open CAD polylines, connected walls, stairs, and connected roads are examples of open polyline-based objects.

For information about editing closed polyline-based objects, see [Editing Closed Polyline-Based Objects on page 228](#).

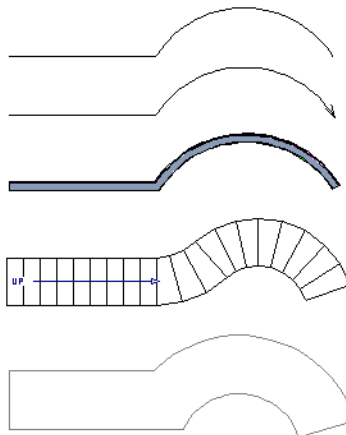

Other objects, such as connected stair and road segments, have additional edit handles that allow you to concentrically adjust the width of all segments of the object.

	<p>If Connect CAD Segments is disabled, clicking on a CAD polyline edge selects the individual edge rather than the entire polyline. See <a href="#">Disconnect Edges on page 212</a>.</p>
---	--

### USING THE EDIT HANDLES

A polyline can be composed of many segments. See [Polylines on page 316](#).

When selected, an open polyline-based object displays a Move handle, a Rotate handle, a Reshape handle at the intersection of each segment, and an Extend handle at each end.

Each straight, line-based segment also has a Move edit handle along its length.

Each curved, arc-based segment has its own Move handle at the center of its chord, a Resize handle and, if it has an unlocked center, a Reshape handle. See [Editing Arc-Based Objects on page 219](#).

When a polyline is selected, the edge that you click nearest is called the selected edge, and certain operations affect only this edge. The Move handle of the selected edge is larger than that of other edges. It displays along the length of a line segment, or at the center of the chord on an arc segment. See [Selected Edge on page 212](#).

Any action performed using the edit handles can be canceled by pressing the Esc key or any two mouse buttons at the same time.



 The behavior of the edit handles depends on the currently active Edit Behavior. See *Defaults, Preferences, and Edit Behaviors on page 206*.

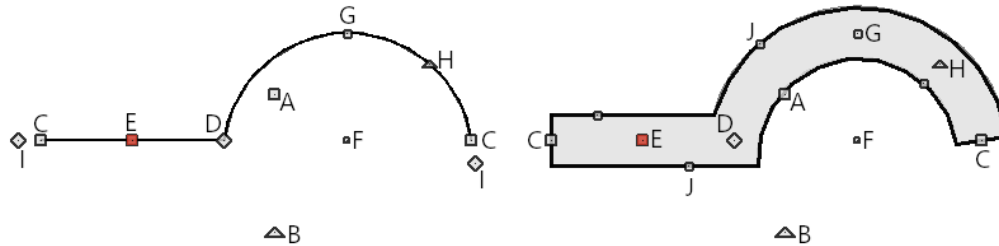

### A. Move

- Click and drag the Move handle to move the object according to the currently active **Edit Behavior** .
- Movement may be limited or stopped by other objects or Snap Behaviors. Move restrictions can be overridden by holding down the Ctrl key while dragging. See *Unrestricted Movement on page 244*.

### B. Rotate

- The **Rotate** handle is used to rotate the object, either about its center or about the current CAD point. Its position varies depending on which edge is currently selected. See *Rotating Objects on page 259*.

### C. Extend

- Click and drag an Extend handle to lengthen or shorten the unconnected end of the selected line or arc segment, or to change the radius of the selected arc. See *Editing Arc-Based Objects on page 219*.
- Right-click and drag it to change the adjacent line into an arc, or vice versa. See *Alternate on page 207*.

### D. Reshape

- Click and drag a Reshape edit handle to change the angle and/or length of the segments on either side of it, or the size of the object, depending on the currently active **Edit Behavior** .

### E. Move Line Segment

- The **Move Line Segment** edit handle is found on straight segments of open polylines and moves the straight section according to the currently active **Edit Behavior** . Adjacent segments may extend or contract in their original directions to maintain their connections.

### F. Move Arc

- Click and drag the Move Arc edit handle to change the radius and/or chord length or position, depending on the currently active **Edit Behavior**  and whether the arc has a locked center. Adjacent segments may extend, contract, or change angle to maintain their connections.

### G. Resize Arc

- Click and drag the Resize Arc edit handle to change the radius, chord length and chord position of the arc segment, depending on the currently active **Edit Behavior**  and whether the arc has a locked center. Adjacent segments may extend, contract, or change angle to maintain their connections.

### H. Reshape Arc

- Click and drag the Reshape Arc edit handle to change the radius of the arc without moving its end points. Only available if the arc has an unlocked center.

### I. Same Line Type

- Drag a diamond-shaped end handle in any direction to draw a new line that shares the original polyline's color, weight, line style, and layer. See [Same Line Type Edit Handles on page 303](#).

### J. Adjust Width

Some open polyline-based objects, such as stairs and roads, have additional handles that allow the width of the object to be adjusted.

- Click and drag a small, round edit handle to increase or decrease the object's width. By default, objects are resized in 1" increments. This Snap Unit is defined in the Plan Defaults dialog. See [General Plan Defaults Dialog on page 92](#).

## USING DIMENSIONS



Dimensions can be used to move or reshape polyline-based objects. See [Moving Objects Using Dimensions on page 483](#).

## USING EXTENSION LINE SNAPS

Extension line snaps, especially tangent snaps, can be useful when editing polyline vertices. See [Extension Snaps on page 161](#).

## USING THE SPECIFICATION DIALOG



Open polyline-based objects can be edited using their specification dialogs. See [Polyline Specification Dialog on page 317](#).

## USING THE EDIT TOOLBAR

A selected open polyline-based object can be edited in a variety of ways using the buttons on the Edit Toolbar.

The following toolbar buttons may display on the Edit Toolbar for a selected open polyline-based object:



**Select Next Object** selects nearby objects instead of the selected object. See [Selecting Objects on page 210](#).



**Open Object** opens the specification dialog for the selected object(s). See [Specification Dialogs on page 21](#).



**Copy/Paste** copies the selected object(s) to the system clipboard so they can be pasted elsewhere. See [Copying and Pasting Objects on page 167](#).



**Delete** deletes the selected object(s). See [Deleting Objects on page 284](#).



**Disconnect Selected Edge** disconnects the selected edge of the polyline, turning it into a separate object. See [Disconnect Edges on page 212](#).



**Transform/Replicate Object** copies, moves, rotates, resizes, or reflects the selected object(s). See [Transform/Replicate Object Dialog on page 266](#).



**Multiple Copy** makes a series of copies at set intervals. See [Multiple Copy on page 172](#).

















**Make Parallel/Perpendicular** makes the selected straight edge parallel or perpendicular to another straight edge. See [Make Parallel/Perpendicular on page 250](#). Not available when the selected edge is an arc.



**Point to Point Move** accurately moves the selected object(s). See [Point to Point Move on page 245](#).



**Add to Library** adds the selected object(s) to the library. See [Add to Library on page 965](#).

-  **Center Object** centers an object along a wall within a room or relative to a cabinet fixture. See *Center Object on page 250*.
-  **Reflect About Object** reflects the selected object(s) about another object. See *Reflecting Objects on page 261*.
-  **View Drawing Group Edit Tools** modifies the selected object's place in the drawing order. See *Drawing Group Edit Tools on page 190*.
-  **Add Break** adds a new corner or pivot point to the selected object. See *Add Break on page 254*.
-  **Complete Break** breaks the selected object into two separate objects. See *Add Break on page 254*.
-  **Reverse Direction** reverses the direction of the selected object(s). See *Reverse Direction on page 262*.
-  **Close Polyline** converts the selected open polyline into a closed polyline. See *Close Polyline on page 228*.
-  **Convert to Spline** changes the selected polyline into a spline. See *Splines on page 324*.
-  **Convert Polyline** converts the object into a special polyline-based object. See *Convert Polyline on page 262*.
-  **Revision Cloud(s) Around Objects** creates a revision cloud around each of the selected object(s). See *Revision Clouds on page 321*.
-  **Change Line/Arc** changes a line-based polyline edge to an arc, or vice versa. See *Change Line/Arc on page 256*.
-  **Convert Curve to Polyline** converts the selected arc into a polyline. See *Convert Curve to Polyline on page 258*. Only available when the selected edge is an arc.
-  **Lock Center** locks the center of the selected curved edge. See *Lock Center on page 223*. Only available when the selected edge is an arc.
-  **Make Arc Tangent** adjusts the selected curved edge and attached edge(s) so they form a smooth shape. See *Make Arc Tangent on page 252*. Only available when the selected edge is an arc attached on one or both ends to another line or arc.
-  **Fence Select** uses the selected object(s) as a selection fence. See *Using a Fence on page 215*.
-  **Object Layer Properties** accesses layer information about the selected object. See *Object Layer Properties on page 187*.
-  **Intersect/Join Two Lines** joins two a non-parallel lines or arcs. See *Intersect/Join Two Lines on page 256*.
-  **Fillet Lines** creates an arc connecting two non-parallel lines. See *Fillet Lines on page 257*. Cannot be used if the adjacent edge is an arc.
-  **Chamfer Lines** creates a line connecting two non-parallel lines. See *Chamfer Lines on page 257*.
-  **Extend Object(s)** lengthens other object(s) until they intersect the selected object. See *Trim and Extend on page 272*.
-  **Trim Object(s)** shortens the length of object(s) intersected by the selected object. See *Trim and Extend on page 272*.
-  **Align/Distribute Objects** specifies how the selected objects are distributed. See *Align/Distribute Objects on page 246*. Only available when multiple objects are selected.
-  **Align/Distribute Along Line** specifies how the selected objects are distributed relative to a line. See *Align/Distribute Along Line on page 248*.

## CLOSE POLYLINE

 An open polyline-based object can be converted into a closed polyline using the **Close Polyline** edit tool. This tool adds an edge to the open polyline, connecting its two ends and closing the gap between them.

**Close Polyline** is not available when **Connect CAD Segments**  is enabled. See [Disconnect Edges on page 212](#).

## Editing Closed Polyline-Based Objects

Closed polyline-based objects are composed of individual line- and arc-based objects joined end-to-end and forming an enclosed area. See [Polylines on page 316](#).

Objects are considered closed polyline-based when they can be edited similar to closed CAD polylines using their edit handles.

Closed CAD polylines, slabs and roof planes are examples of closed polyline-based objects.

Some objects, notably walls, have closed polyline-based editing behavior only when they are selected on certain surfaces in 3D views. See [Editing Walls on page 368](#).

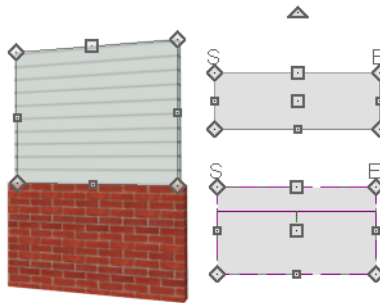

For information about editing open polyline-based objects, see [Editing Open Polyline-Based Objects on page 224](#).

 If **Connect CAD Segments** is disabled, clicking on a polyline edge selects the individual edge rather than the entire polyline. See [Disconnect Edges on page 212](#).

## USING THE EDIT HANDLES

A polyline can be composed of many segments. See [Polylines on page 316](#).

When selected, a closed polyline-based object displays a Move handle, a Rotate handle, and a Reshape handle at the intersection of each segment.

Each straight, line-based segment has a Move edit handle along its length.

Each curved, arc-based segment has its own Move handle at the center of its chord, a Resize handle and, if it has an unlocked center, a Reshape handle. See [Editing Arc-Based Objects on page 219](#).

When a polyline is selected, the edge that you click nearest is called the selected edge, and certain operations affect only this edge. The Move handle of the selected edge is larger than that of other edges. It displays along the length of a line segment, or at the center of the chord on an arc segment. See [Selected Edge on page 212](#).

Any action performed using the edit handles can be canceled by pressing the Esc key or any two mouse buttons at the same time.

 The behavior of the edit handles may depend on the currently active Edit Behavior. See [Defaults, Preferences, and Edit Behaviors on page 206](#).

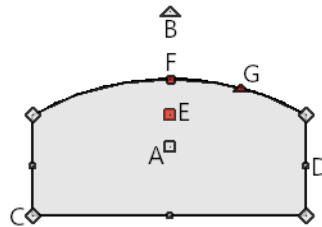

#### A. Move

- Click and drag the Move handle to move the object according to the currently active **Edit Behavior** .
- Movement may be limited or stopped by other objects or Snap Behaviors. Move restrictions can be overridden by holding down the Ctrl key while dragging. See [Unrestricted Movement on page 244](#).

#### B. Rotate

- The **Rotate** handle is used to rotate the object, either about its center or about the current CAD point. Its position varies depending on which edge is currently selected. See [Rotating Objects on page 259](#).

#### C. Reshape

- Click and drag a Reshape edit handle to change the angle and/or length of the segments on either side of it, or the size of the object, depending on the currently active **Edit Behavior** .

#### D. Move Line Segment

- The **Move Line Segment** edit handle is found on straight segments of closed polylines and moves the straight section according to the currently active **Edit Behavior** . Adjacent segments may extend or contract in their original directions to maintain their connections.

#### E. Move Arc

- Click and drag the Move Arc edit handle to change the radius and/or chord length or position, depending on the currently active **Edit Behavior**  and whether the arc has a locked center. Adjacent segments may extend, contract, or change angle to maintain their connections.

#### F. Resize Arc

- Click and drag the Resize Arc edit handle to change the radius, chord length and chord position of the arc segment, depending on the currently active **Edit Behavior**  and whether the arc has a locked center. Adjacent segments may extend, contract, or change angle to maintain their connections.

#### G. Reshape Arc

- Click and drag the Reshape Arc edit handle to change the radius of the arc without moving its end points. Only available if the arc has an unlocked center.

Other objects, such as connected road segments, have additional edit handles that allow you to concentrically adjust the width of all segments of the object.

## USING DIMENSIONS

 Dimensions can be used to move or reshape closed polyline-based objects. See *Moving Objects Using Dimensions on page 483*.

## USING EXTENSION LINE SNAPS

Extension line snaps, especially tangent snaps, can be useful when editing polyline vertices. See *Extension Snaps on page 161*.

## USING THE SPECIFICATION DIALOG

 Closed polyline-based objects can be edited using their specification dialogs. See *Polyline Specification Dialog on page 317*.

## USING THE EDIT TOOLBAR

A selected closed polyline-based object can be edited in a variety of ways using the buttons on the Edit Toolbar.

The following toolbar buttons may display on the Edit Toolbar for a selected closed polyline-based object:



**Select Next Object** selects nearby objects instead of the selected object. See *Selecting Objects on page 210*.



**Open Object** opens the specification dialog for the selected object(s). See *Specification Dialogs on page 21*.



**Copy/Paste** copies the selected object(s) to the system clipboard so they can be pasted elsewhere. See *Copying and Pasting Objects on page 167*.



**Delete** deletes the selected object(s). See *Deleting Objects on page 284*.



**Disconnect Selected Edge** disconnects the selected edge of the polyline, turning it into a separate object. See *Disconnect Edges on page 212*.



**Transform/Replicate Object** copies, moves, rotates, resizes, or reflects the selected object(s). See *Transform/Replicate Object Dialog on page 266*.



**Multiple Copy** makes a series of copies at set intervals. See *Multiple Copy on page 172*.



**Make Parallel/Perpendicular** makes the selected straight edge parallel or perpendicular to another straight edge by either rotating the selected edge or the entire polyline. See *Make Parallel/Perpendicular on page 250*. Not available when the selected edge is an arc.



**Point to Point Move** accurately moves the selected object(s). See *Point to Point Move on page 245*.



**Edit Pattern** allows you to edit a selected object's custom fill pattern. See *Editing Custom Patterns on page 197*. Only available when a single object with a custom fill pattern is selected.



**Add to Library** adds the selected object(s) to the library. See *Add to Library on page 965*.



**Center Object** centers an object along a wall within a room or relative to a cabinet fixture. See *Center Object on page 250*.



**Reflect About Object** reflect the selected object(s) about another object. See *Reflecting Objects on page 261*.





**View Drawing Group Edit Tools** modifies the selected object's place in the drawing order. See *Drawing Group Edit Tools on page 190*.

-  **Add Break** adds a new corner or pivot point to the selected object. See [Add Break on page 254](#).
-  **Complete Break** breaks an edge of the selected object into two separate objects. See [Add Break on page 254](#).
-  **Reverse Direction** reverses the direction of the selected object(s). See [Reverse Direction on page 262](#).
-  **Convert to Spline** changes the selected polyline into a spline. See [Splines on page 324](#).
-  **Union** joins two or more objects. See [Union, Intersection, and Subtraction on page 274](#). Not available for objects specified as holes.
-  **Intersection** creates a new object defined by the areas shared by the original objects. See [Union, Intersection, and Subtraction on page 274](#). Not available for objects specified as holes.
-  **Subtract** removes the area shared by two objects. See [Union, Intersection, and Subtraction on page 274](#). Not available for objects specified as holes.
-  **Convert Polyline** converts the object into a special polyline-based object. See [Convert Polyline on page 262](#).
-  **Revision Cloud(s) Around Objects** creates a revision cloud around each of the selected object(s). See [Revision Clouds on page 321](#).
-  **Change Line/Arc** changes a line-based polyline edge to an arc, or vice versa. See [Change Line/Arc on page 256](#).
-  **Convert Curve to Polyline** converts the selected arc into a polyline. See [Convert Curve to Polyline on page 258](#). Only available when the selected edge is an arc.
-  **Lock Center** locks the center of the selected curved edge. See [Lock Center on page 223](#). Only available when the selected edge is an arc.
-  **Make Arc Tangent** adjusts the selected curved edge and attached edge(s) so they form a smooth shape. See [Make Arc Tangent on page 252](#). Only available when the selected edge is an arc attached on one or both ends to another line or arc.
-  **Fence Select** allows you to use the selected object(s) as a selection fence. See [Using a Fence on page 215](#).
-  **Object Layer Properties** accesses layer information about the selected object. See [Object Layer Properties on page 187](#).
-  **Intersect/Join Two Lines** joins two non-parallel lines or arcs. See [Intersect/Join Two Lines on page 256](#).
-  **Fillet Lines** creates an arc connecting two non-parallel lines. See [Fillet Lines on page 257](#). Cannot be used if the adjacent edge is an arc.
-  **Chamfer Lines** creates a straight line between two non-parallel lines. See [Chamfer Lines on page 257](#).
-  **Extend Object(s)** lengthens other object(s) until they intersect the selected object. See [Trim and Extend on page 272](#).
-  **Trim Object(s)** shortens the length of object(s) intersected by the selected object. See [Trim and Extend on page 272](#).
-  **Align/Distribute Objects** specifies how the selected objects are distributed. See [Align/Distribute Objects on page 246](#). Only available when multiple objects are selected.
-  **Align/Distribute Along Line** specifies how the selected objects are distributed relative to a line. See [Align/Distribute Along Line on page 248](#).
-  **Create Hole** creates a rectangular hole in the selected object. See [Polyline Holes on page 232](#), below.

## POLYLINE HOLES

Most closed polyline-based objects can contain one or more holes. There are several ways to create a hole; the methods available may vary depending on the object type.

- Some closed polyline-based object drawing tools have an associated Hole drawing tool.
- Many closed polyline-based objects have a **Hole in** check box on the GENERAL panel of their specification dialog that will convert the object into a hole if it is located within a larger object of the same type.
- Click the **Create Hole**  edit button, then click and drag to draw a rectangular hole in the selected object. If the selected object has an associated Hole tool or Hole in check box, the Create Hole will create an object of that type; if the selected object does not, a standard closed polyline will be created.
- Using the **Convert Polyline**  tool, a CAD Polyline can be converted into a variety of different types of objects, some of which may contain holes. If the selected CAD polyline contains any holes, those holes will be converted to holes in the converted object, when appropriate. See [Convert Polyline on page 262](#).
- A CAD Polyline can be converted into a hole in a floor, ceiling, or roof assembly using the **Convert Polyline**  tool.

Holes in polyline-based objects can be selected, edited, and deleted independent of their containing object. Bear in mind that by definition, a hole cannot exist where its containing object does not. It must be drawn entirely within the extents of its containing object without touching or crossing over an edge.

A few closed polyline-based objects cannot have holes: notably, Molding Polylines and Rope Lights.

---

## Editing Box-Based Objects

Objects are considered box-based when they can be edited similar to CAD boxes using their edit handles.

Box-based objects are similar to closed polyline-based objects, but must always have four sides with right-angled corners.

In addition to the CAD Box tools, Text objects, many library symbols, CAD blocks, pictures and images are examples of box-based objects.

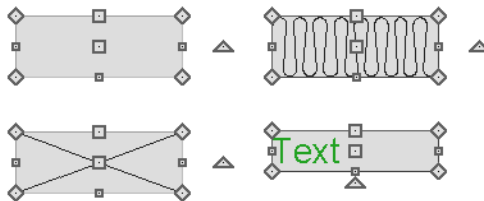

### USING THE EDIT HANDLES

When selected, a box-based object displays ten edit handles. Unlike polylines, boxes must always have four sides with right-angled corners.

Any action performed using the edit handles can be canceled by pressing the Esc key or any two mouse buttons at the same time.



The behavior of the edit handles may depend on the currently active Edit Behavior. See [Defaults, Preferences, and Edit Behaviors on page 206](#).



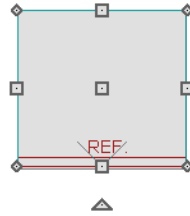

- Click and drag the Move handle to move the object according to the currently active **Edit Behavior** . See *Defaults, Preferences, and Edit Behaviors on page 206*.

Movement may be limited or stopped by other objects or Snap Behaviors. Move restrictions can be overridden by holding down the Ctrl key while dragging. See *Unrestricted Movement on page 244*.

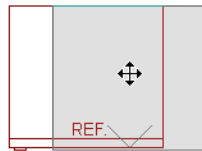

- The four **Resize** handles located at each corner are used to increase or decrease the size of the object.

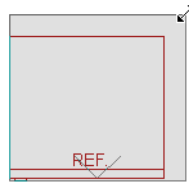

- The four **Extend** handles display along each edge. If you select an object on an edge, the Extend handle displays at the point where you clicked; otherwise, it displays at the center of the edge.

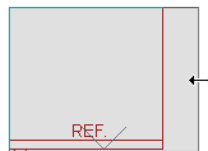

- The triangular **Rotate** handle located near the selected edge of the object is used to rotate it either about its center or the current CAD point. The pointer changes to a circular arrow  when moved over this handle. See *Rotating Objects on page 259*.

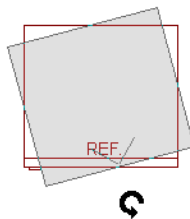

## USING DIMENSIONS



Dimensions can be used to move or reshape box-based objects. See *Moving Objects Using Dimensions on page 483*.



















## USING THE SPECIFICATION DIALOG

 Box-based objects can be edited using their specification dialogs. See *Box Specification Dialog on page 320*.

## USING THE EDIT TOOLBAR

A selected box-based object can be edited in a variety of ways using the buttons on the Edit Toolbar.

The following toolbar buttons may display on the Edit Toolbar for a selected box-based object:

-  **Select Next Object** selects nearby objects instead of the selected object. See *Selecting Objects on page 210*.
-  **Open Object** opens the specification dialog for the selected object(s). See *Specification Dialogs on page 21*.
-  **Copy/Paste** copies the selected object(s) to the system clipboard so they can be pasted elsewhere. See *Copying and Pasting Objects on page 167*.
-  **Delete** deletes the selected object(s). See *Deleting Objects on page 284*.
-  **Transform/Replicate Object** copies, moves, rotates, resizes, or reflects the selected object(s). See *Transform/Replicate Object Dialog on page 266*.
-  **Multiple Copy** makes a series of copies at set intervals. See *Multiple Copy on page 172*.
-  **Make Parallel/Perpendicular** makes the selected straight edge parallel or perpendicular to another straight edge. Not available when the selected edge is an arc. See *Make Parallel/Perpendicular on page 250*.
-  **Point to Point Move** accurately moves the selected object(s). See *Point to Point Move on page 245*.
-  **Center Object** centers an object along a wall within a room or relative to a cabinet fixture. See *Center Object on page 250*.
-  **Reflect About Object** reflects the selected object(s) about another object. See *Reflecting Objects on page 261*.
-  **View Drawing Group Edit Tools** modifies the selected object's place in the drawing order. See *Drawing Group Edit Tools on page 190*.
-  **Convert Polyline** converts the object into a special polyline-based object. See *Convert Polyline on page 262*.
-  **Revision Cloud(s) Around Objects** creates a revision cloud around each of the selected object(s). See *Revision Clouds on page 321*.
-  **Extend Object(s)** lengthens other object(s) until they intersect the selected object. See *Trim and Extend on page 272*.
-  **Trim Object(s)** shortens the length of object(s) intersected by the selected object. See *Trim and Extend on page 272*.
-  **Align/Distribute Objects** specifies how the selected objects are distributed. See *Align/Distribute Objects on page 246*. Only available when multiple objects are selected.
-  **Object Layer Properties** accesses layer information about the selected object. See *Object Layer Properties on page 187*.
-  **Align/Distribute Along Line** aligns the selected object(s) relative to a line-based object. See *Align/Distribute Along Line on page 248*.

## Editing Spline-Based Objects

A Spline is a curve that passes smoothly through a set of points, or vertices. Splines are typically used in situations where an irregular, free-flowing curve is needed.

Objects are considered spline-based when they can be edited similar to CAD splines using their edit handles. See *Splines on page 324*.

Sprinkler lines, spline terrain curbs, spline terrain walls and both round and kidney-shaped terrain features are spline-based objects. See *Terrain on page 1243*.



### USING THE EDIT HANDLES

When a spline is selected, several different types of handles display. How many handles display depends on whether the **Advanced Splines**  edit button is on or not. See *Advanced Splines on page 237*.

Any action performed using the edit handles can be canceled by pressing the Esc key or any two mouse buttons at the same time.

 The behavior of the edit handles may depend on the currently active Edit Behavior. See *Defaults, Preferences, and Edit Behaviors on page 206*.

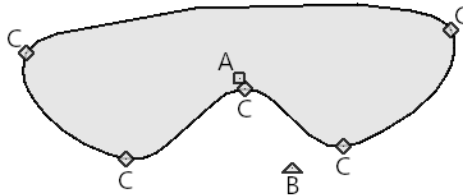

#### A. Move

- Click and drag the Move handle to move the object according to the currently active **Edit Behavior** . See *Defaults, Preferences, and Edit Behaviors on page 206*.
- Movement may be limited or stopped by other objects or Snap Behaviors. Move restrictions can be overridden by holding down the Ctrl key while dragging. See *Unrestricted Movement on page 244*.

#### B. Rotate

- Click and drag the Rotate edit handle to rotate the entire spline.

#### C. Vertex

- The Vertex edit handles display along the spline at each vertex. Click and drag a Vertex edit handle to change the length, angle and curve of adjacent segments without affecting other vertices.

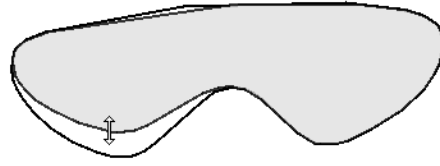

### Same Line Type

- Drag a diamond-shaped end handle in any direction to draw a new spline segment that shares the original spline's color, weight, line style, and layer. See *Same Line Type Edit Handles on page 303*.



### Advanced Splines

- Additional edit handles, called Control Handles, display beside each spline vertex when **Advanced Splines** is enabled. See *Advanced Splines on page 237*.



- A. Vertex
- B. Control Handle
- C. Tangent Line

## USING THE SPECIFICATION DIALOG

 Spline-based objects can be edited using their specification dialogs. See *Polyline Specification Dialog on page 317*.

## USING THE EDIT TOOLBAR

A selected spline-based object can be edited in a variety of ways using the buttons on the Edit Toolbar.

The following toolbar buttons may display on the Edit Toolbar for a selected spline-based object:



**Select Next Object** selects nearby objects instead of the selected object. See *Selecting Objects on page 210*.



**Open Object** opens the specification dialog for the selected object(s). See *Specification Dialogs on page 21*.



**Copy/Paste** copies the selected object(s) to the system clipboard so they can be pasted elsewhere. See *Copying and Pasting Objects on page 167*.



**Delete** deletes the selected object(s). See *Deleting Objects on page 284*.











**Transform/Replicate Object** copies, moves, rotates, resizes, or reflects the selected object(s). See *Transform/Replicate Object Dialog on page 266*.



**Multiple Copy** makes a series of copies at set intervals. See *Multiple Copy on page 172*.



**Make Parallel/Perpendicular** makes the selected spline edge parallel or perpendicular to another straight edge. See *Make Parallel/Perpendicular on page 250*.

-  **Point to Point Move** accurately moves the selected object(s). See *Point to Point Move on page 245*.
-  **Add to Library** adds the selected object(s) to the library. See *Add to Library on page 965*.
-  **Center Object** centers an object along a wall within a room or relative to a cabinet fixture. See *Center Object on page 250*.
-  **Reflect About Object** reflects the selected object(s) about another object. See *Reflecting Objects on page 261*.
-  **View Drawing Group Edit Tools** modifies the selected object's place in the drawing order. See *Drawing Group Edit Tools on page 190*.
-  **Add Break** adds a new corner or pivot point to the selected object. See *Add Break on page 254*.
-  **Complete Break** breaks an edge of the selected object into two separate objects. See *Add Break on page 254*.
-  **Trim Object(s)** shortens the length of object(s) intersected by the selected object. See *Trim and Extend on page 272*.
-  **Extend Object(s)** lengthens other object(s) until they intersect the selected object. See *Trim and Extend on page 272*.
-  **Reverse Direction** reverses the direction of the selected object(s). See *Reverse Direction on page 262*.
-  **Convert Polyline** converts the object into a special polyline-based object. See *Convert Polyline on page 262*.
-  **Revision Cloud(s) Around Objects** creates a revision cloud around each of the selected object(s). See *Revision Clouds on page 321*.
-  **Fence Select** uses the selected object(s) as a selection fence. See *Using a Fence on page 215*.
-  **Convert Spline to Polyline** converts the selected spline into a polyline. See *Convert Spline to Polyline on page 266*.
-  **Object Layer Properties** accesses and edits layer information about the selected object. See *Object Layer Properties on page 187*.
-  **Advanced Splines** enables advanced spline editing for the selected spline. See *Advanced Splines on page 237*.
-  **Straighten Spline Segment** straightens a segment of an Advanced Spline. See *Straighten Spline Segment on page 239*. Only available when Advanced Splines is turned on.
-  **Lock Control Handle Angle** maintains the relative angle between the vertex and its control handles. See *Lock Control Handle Angle on page 238*. Only available when Advanced Splines is turned on.
-  **Align/Distribute Objects** specifies how the selected objects are distributed. See *Align/Distribute Objects on page 246*. Only available when multiple objects are selected.
-  **Align/Distribute Along Line**- Click this, then click on a line-based object align the selected object(s) relative to that line. See *Align/Distribute Along Line on page 248*.

## ADVANCED SPLINES

-  Click the **Advanced Splines** edit button to display additional edit handles called Control Handles on the selected spline. These edit handles allow you to reshape the spline with more control at each vertex.



- A. Vertex
- B. Control Handle
- C. Tangent Line

The line between the two Control Handles is tangent to the spline's curvature at the point of the vertex.

- Move a Control Handle around the vertex to change the direction of the spline's curvature at the vertex point.

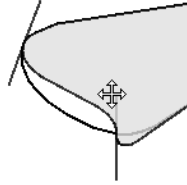

- Move a Control Handle away from the vertex to increase the curvature of the spline segment adjacent to that handle.

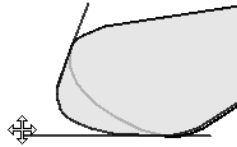

- Move a Control Handle towards the vertex to decrease the curvature.

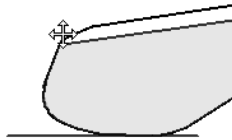

You can specify that splines be Advanced Splines by default in the Preferences dialog. See [CAD Panel on page 114](#).

### LOCK CONTROL HANDLE ANGLE



The **Lock Control Handle Angle** edit button is available when Advanced Splines is enabled, and is turned on by default. This tool maintains the relative angle between the vertex and its Control Handles.

Clicking to uncheck the **Lock Control Handle Angle**  edit button frees the control of the relative edit angles between each vertex and its Control Handles. The Control Handles can now be adjusted independent of one another.

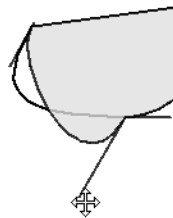

Rechecking **Lock Control Handle Angle**  will again lock the handles at their current angles.

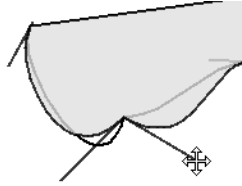

### STRAIGHTEN SPLINE SEGMENT

 The **Straighten Spline Segment** edit button allows you to straighten the selected segment of an Advanced Spline between two vertex points.

To use, click on the spline segment that you would like to straighten, then click the **Straighten Spline Segment**  edit button. See *Selected Edge on page 212*.

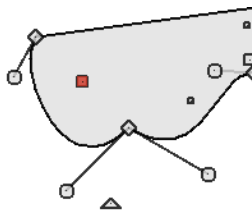

When a spline segment has been straightened, the Control Handles and tangent lines associated with it are aligned with the segment. If either Control Handle is moved around the vertex, the straightened edge will become curved again.

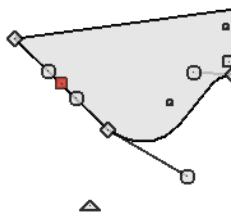



---

## Editing Circles, Ovals and Ellipses

 Objects created using the **Circle Tools** are unusual in that no architectural objects share their functionalities.

### USING THE EDIT HANDLES

When selected, circles, ovals and ellipses display eleven edit handles.

Unlike **Ovals**  and **Ellipses** , a **Circle**  cannot be edited into any other shapes; it can only be a circle unless it is converted into a polyline. See *Convert Curve to Polyline on page 258*.

Any action performed using the edit handles can be canceled by pressing the Esc key or any two mouse buttons at the same time.

 The behavior of the edit handles may depend on the currently active Edit Behavior. See *Defaults, Preferences, and Edit Behaviors on page 206*.

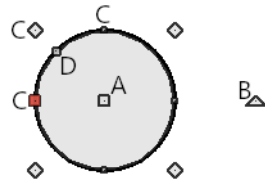

- A. Move
- B. Rotate
- C. Reshape
- D. Concentric Resize

### Move

- Click and drag the Move handle to move the object according to the currently active **Edit Behavior** . See *Defaults, Preferences, and Edit Behaviors on page 206*.
- Movement may be limited or stopped by other objects or Snap Behaviors. Move restrictions can be overridden by holding down the Ctrl key while dragging. See *Unrestricted Movement on page 244*.

### Rotate

- Click and drag the Rotate handle of an oval or ellipse to change its orientation.

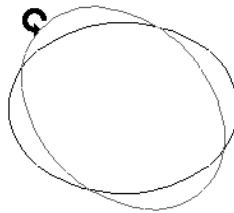

### Reshape

- The eight edit handles beyond the perimeter are Reshape edit handles. Move them in or out to resize and reshape an oval or ellipse.

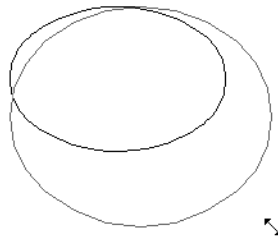

- Unlike ovals and ellipses, circles cannot be reshaped. When a Reshape handle is dragged on a circle, it is only resized.

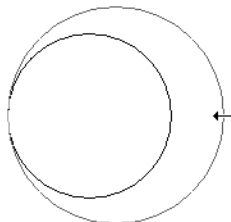



### Concentric Resize

- The Concentric Resize edit handle displays on the perimeter of a circle between a corner Reshape handle and the center. Click and drag this handle to resize the circle without moving its center point.

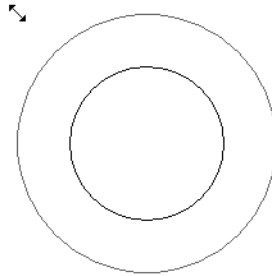

### USING DIMENSIONS



Dimensions can be used to move or resize circle-based objects. See [Moving Objects Using Dimensions on page 483](#).

### USING THE SPECIFICATION DIALOG



Circles, ovals and ellipses can be edited using their specification dialogs. See [Circle/Oval/Ellipse Specification Dialog on page 315](#).

### USING THE EDIT TOOLBAR

A selected circle, oval or ellipse can be edited in a variety of ways using the buttons on the Edit Toolbar.

The following toolbar buttons may display on the Edit Toolbar for a selected circle, oval or ellipse:



**Select Next Object** selects nearby objects instead of the selected object. See [Selecting Objects on page 210](#).



**Open Object** opens the specification dialog for the selected object(s). See [Specification Dialogs on page 21](#).



**Copy/Paste** copies the selected object(s) to the system clipboard so they can be pasted elsewhere. See [Copying and Pasting Objects on page 167](#).



**Delete** deletes the selected object(s). See [Deleting Objects on page 284](#).



**Transform/Replicate Object** copies, moves, rotates, resizes, or reflects the selected object(s). See [Transform/Replicate Object Dialog on page 266](#).



**Multiple Copy** makes a series of copies at set intervals. See [Multiple Copy on page 172](#).



**Make Parallel/Perpendicular** makes the selected edge parallel or perpendicular to another straight edge. See [Make Parallel/Perpendicular on page 250](#).











**Point to Point Move** accurately moves the selected object(s). See [Point to Point Move on page 245](#).



**Center Object** centers an object along a wall within a room or relative to a cabinet fixture. See [Center Object on page 250](#).



**Reflect About Object** reflects the selected object(s) about another object. See [Reflecting Objects on page 261](#).

-  **View Drawing Group Edit Tools** modifies the selected object's place in the drawing order. See *Drawing Group Edit Tools on page 190*.
-  **Extend Object(s)** lengthens other object(s) until they intersect the selected object. See *Trim and Extend on page 272*. Not available for ellipses.
-  **Trim Object(s)** shortens the length of object(s) intersected by the selected object. See *Trim and Extend on page 272*. Not available for ellipses.
-  **Convert Polyline** converts the object into a special polyline-based object. See *Convert Polyline on page 262*.
-  **Revision Cloud(s) Around Objects** creates a revision cloud around each of the selected object(s). See *Revision Clouds on page 321*.
-  **Convert Curve to Polyline** converts the selected circle, oval or ellipse into a polyline. See *Convert Curve to Polyline on page 258*.
-  **Align/Distribute Objects** specifies how the selected objects are distributed. See *Align/Distribute Objects on page 246*. Only available when multiple objects are selected.
-  **Object Layer Properties** accesses layer information for the selected object. See *Object Layer Properties on page 187*.
-  **Align/Distribute Along Line** aligns the selected object(s) relative to a line-based object. See *Align/Distribute Along Line on page 248*.

---

## Editing Multiple Objects

There are a number of options for accurately and efficiently editing multiple objects at once. See *Selecting Multiple Objects on page 213*.

### DYNAMIC DEFAULTS

Dynamic defaults are a useful way to apply certain attributes to multiple objects of the same type throughout a plan. They are found in the defaults dialogs for a variety of different architectural objects, and when these default values are changed, all objects that are set to use them throughout the current plan will update automatically. Dynamic defaults are particularly valuable for applying critical defaults like ceiling heights and floor structure. See *Dynamic Defaults on page 79*.

### IN THE SPECIFICATION DIALOG

When multiple objects are selected, the **Open Object** edit button is often available. The settings available in a shared specification dialog will vary, depending on the types of objects that are selected. If the objects are of the same type, their shared specification dialog will have many of the settings that their individual specification dialogs have; if they are not similar, the dialog may have only a few settings. When multiple objects are selected, their shared specification dialog may also have settings in a “No Change” state. See *Specification Dialogs on page 21*.

### USING THE EDIT TOOLBAR

Group-selected objects can also be edited using the buttons on edit toolbar. The available tools will vary, depending on which types of objects are selected. See *The Edit Toolbar on page 130*.

### OBJECT PAINTER

 The **Object Eyedropper** tool allows you to apply selected attributes of one object to other, similar objects. See *Object Eyedropper on page 282*.

## Moving Objects

Objects can be moved using the edit handles as well as a variety of edit tools. Multiple selected objects can also be moved as a group. See [Selecting Objects on page 210](#).

### USING THE EDIT HANDLES



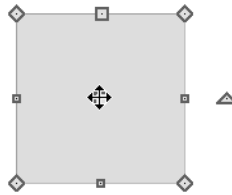



Select an object, then click the **Move** edit handle and drag it to a new location. When your pointer is over the Move handle, it displays a four-headed arrow .



As an object is moved, it jumps at set increments when **Grid Snaps**  are enabled. See [Grid Snaps on page 163](#).

When **Object Snaps**  are enabled, a selected object snaps to its original location if it passes over that location while being moved.

The behavior of the Move edit handle varies depending on the currently active **Edit Behavior** . See [Defaults, Preferences, and Edit Behaviors on page 206](#).

- If the **Default** , **Resize** , **Concentric**  or **Fillet**  edit behavior is active, the object moves orthogonal, or at a right angle to, any of its edges.
- If the **Alternate** **Alt**  edit behavior is active, the selected object(s) can be moved at Allowed Angles if **Angle Snaps**  are enabled, or orthogonal to any of its edges if they are not. See [Alternate on page 207](#).
- If the **Move** edit behavior is active, the selected object(s) can be moved by clicking and dragging any edit handle that would otherwise be used for resizing. See [Move on page 207](#).

You can temporarily slow the movement of your mouse as you drag an edit handle by holding down the Shift key on your keyboard.

### BUMPING/PUSHING

 When **Edit> Snap Settings> Bumping/Pushing** is enabled, architectural objects will bump into and can push one another as they are moved. This setting also affects CAD and CAD-based objects with **CAD Stops Move** and/or **Wall Stops Move** enabled. See [Line Style Panel on page 305](#).

When an object bumps into another object while it is being moved, it stops. If you do not release the mouse button and continue to drag, however, the selected object resumes movement and continues past the obstructing object.

Instead of dragging through and past obstructing objects, you can instead push them. To do this, bump an object into an obstructing object and release the mouse button. Then, click and drag the Move edit handle a second time in the same direction.

Walls, wall openings, cabinets, furnishings and fixtures, and CAD and CAD-based objects are examples of objects that can bump into as well as push other objects.

By default, **Bumping/Pushing**  does not affect objects moved using dimensions or the Enter Coordinates dialog. See *Moving Objects Using Dimensions on page 483* and *Entering Coordinates on page 166*.

The **Maximum Bump Distance**, which is the distance you must drag to override bumping, is set in the Preferences dialog. **Bumping/Pushing for Type-in Movement** can also be enabled there. See *Snap Properties Panel on page 119*.

Certain types of objects, notably roof planes, and objects on locked layers can be bumped but cannot be pushed. See *Layer Display Options Dialog on page 179*.

## CAD STOPS MOVE/WALL STOPS MOVE

CAD and CAD-based objects can be set to stop at other CAD objects and/or at walls as they are being moved. See *Line Style Panel on page 305*.

Some objects, such as cross boxes, framing members and insulation, are automatically set to stop when moved against other CAD objects.

**CAD Stops Move** and **Wall Stops Move** do not function if **Bumping/Pushing**  is turned off.

## UNRESTRICTED MOVEMENT

Many objects have restrictions placed on their movement by their own properties or specification settings. Architectural objects, for example, bump into other 3D objects as they are being moved when **Bumping/Pushing**  is enabled.

CAD-based objects can be set to stop at other CAD objects or at walls. See *Line Style Panel on page 305*.

Other move restrictions are activated by the **Snap Settings** . See *Snap Behaviors on page 159*.

These restrictions can be overridden when necessary by holding down the Ctrl key while dragging to move an object.

### *To move an object freely*

1. Select the object.
2. Hold down the Ctrl key.
3. Click the Move edit handle and drag it to the new location.

You can also press the Ctrl key while dragging an object's Move handle to override move restrictions.

## NUDGING

You can use your keyboard to move a selected object or objects by single **Snap Grid** increments in 2D and 3D views. This is referred to as nudging. See *Grid Snaps on page 163*.

By default, the Nudge commands are not assigned hotkeys and the arrow keys are programmed to nudge a selected object. If you press an arrow key when no object is selected, you will instead pan the view window. See *Panning the Display on page 154*.

If you wish, you can program assign hotkeys to the Nudge commands. When Nudge hotkeys are assigned, they cannot also be used to pan the display. See *Hotkeys on page 137*.

### *In Plan View*

To nudge an object in plan view, select it and press any of the four arrow keys: Up, Down, Left, or Right. These directions are relative to the Snap Grid: if **Rotate Plan View**  is used to rotate plan view, the definitions of up, down, left, and right are affected. See *Rotate Plan View on page 147*.

### ***In 3D Views***

To nudge an object in camera views, overviews, and cross section/elevation views, you can program the keys of your choice for use as nudging hotkeys. See [Hotkeys on page 137](#).

In 3D views, nudging is relative to the selected surface. If, for example, you select the front of a cabinet in 3D and nudge it to the left, it will move to the left in plan view. If you instead select the back of a cabinet in 3D and nudge it to the left, it will move to the right in plan view.

When multiple objects are selected, the surface that was clicked on last is considered the selected surface. When nudged, all selected objects will move relative to that surface. See [Shift and Ctrl Select on page 214](#).

If an object is rotated, the directions that it can be nudged in 2D are not affected; however, in 3D, they are. If, for example, a cabinet is rotated 45°, it will nudge to the left as defined by the Snap Grid in plan view. When nudged in 3D, however, it will move at a 45° angle to the Snap Grid: or parallel to the selected surface.





## **POINT TO POINT MOVE**



The **Point to Point Move** edit button allows a selected object or group of objects to be accurately moved.

The Point to Point Move tool is often most effective when used in combination with Object Snaps. Bear in mind that it is also affected by Grid Snaps, and that in some situations you may want to toggle snaps off. See [Snap Behaviors on page 159](#).

### ***To use Point to Point Move***

1. Select one or more objects that you would like to move, then click the **Point to Point Move**  edit button.
2. A temporary CAD point  preview follows the mouse pointer, which displays the Point A  icon. Click on a point that you want to accurately reposition: a temporary point is placed at that location.
3. Move the mouse pointer:
  - An extension line extends from Point A to the pointer, which now displays the Point B  icon and is followed by a preview outline of the selection and another temporary point preview.
  - You can move the mouse at any angle, making it easier to use Object Snaps.
  - Hold down the Shift key to moved at Allowed Angles only. See [Angle Snaps on page 162](#).
4. Click on the point on an object or in the plan where you would like the selected point to be relocated when it is moved.
5. The selected object(s) are moved so that they maintain their position relative to the point and both temporary points are deleted.

To retain a copy of the selected object(s) in the original location, the **Copy/Paste**  edit button before clicking the **Point to Point Move** button. See [To use Copy/Paste with other edit tools on page 170](#).

**Point to Point Move** can also be used with the **Edit Area**  tools. See [Edit Area Tools on page 269](#).

## **USING CENTER OBJECT**



The **Center Object** edit button allows you to move walls, cabinets and other objects so that they are centered along a wall within a room or relative to a window or cabinet. See [Center Object on page 250](#).

## MOVE TO FRAMING REFERENCE



Framing members can be positioned relative to a Framing Reference using the **Move to Framing Reference** edit tool. See [Framing Reference Markers on page 875](#).

## USING DIMENSIONS



Objects or the selected edges of some objects can be moved using dimensions. See [Moving Objects Using Dimensions on page 483](#).

When **Bumping/Pushing for Type-in Movement** is checked in the Preferences dialog, adjacent objects can be pushed when an object is moved using dimensions.

## ENTER COORDINATES

Objects or the selected edges of some objects can be moved using the Enter Coordinates dialog. See [Entering Coordinates on page 166](#).

To push additional objects using the Enter Coordinates dialog, check **Bumping/Pushing for Type-in Movement** in the Preferences dialog, then bump an object into another object. Click and drag a second time to begin pushing and press the Tab key to open the Enter Coordinates dialog.

Note: By default, objects moved using either the Enter Coordinates dialog or dimensions are not subject to Bumping/Pushing. See [Bumping/Pushing on page 243](#).

## USING THE TRANSFORM/REPLICATE OBJECT DIALOG



Objects and groups of objects can be moved relative to themselves or an absolute location using the Transform  
••• Replicate Object dialog. See [Transform/Replicate Object Dialog on page 266](#).

---

# Aligning Objects

It is often important to align objects such as text boxes, roof plane edges, or walls, or to align objects on different floors. There are several methods to choose from.

## ALIGN/DISTRIBUTE OBJECTS



Select two or more objects and click the **Align/Distribute Objects** edit button to open the Align/Distribute Objects dialog and specify how to align or distribute the selected objects vertically and/or horizontally.

**Align/Distribute Objects** is available in all views for most CAD objects. For architectural objects, it is only available in plan view.

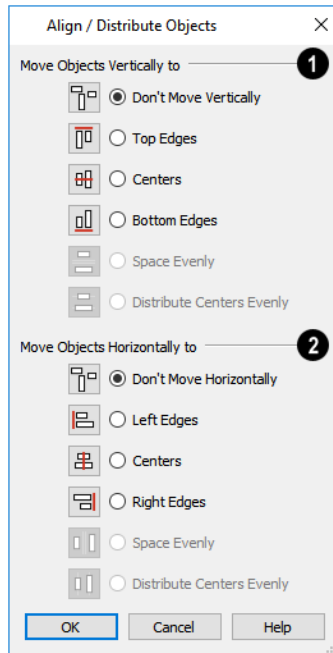

## 1 Move Objects Vertically to

Specify what edges or points on the selected objects to **Move Objects Vertically to**.

- Select **Don't Move Vertically** to make no changes to the vertical alignment of the selected objects.
- Select **Top Edges** to move the selected objects so their top edges are aligned. The object with the highest top edge in the selection set does not move.
- Select **Centers** to move the selected objects so their centers are aligned vertically. The object with the center closest to the vertical center of the selection set does not move.
- Select **Bottom Edges** to move the selected objects so their bottom edges are aligned. The object with the lowest bottom edge in the selection set does not move.
- Select **Space Evenly** to produce consistent vertical spacing between the top and bottom edges of the objects in the selection set. The highest and lowest objects on screen do not move and the ones in between move up or down as needed. Only available if three or more objects are selected.
- Select **Distribute Centers Evenly** to produce consistent on-center vertical spacing between the objects in the selection set. The highest and lowest objects on screen do not move and the ones in between move up or down as needed. Only available if three or more objects are selected.

## 2 Move Objects Horizontally to

Specify what edges or points on the selected objects to **Move Objects Horizontally to**.

- Select **Don't Move Horizontally** to make no changes to the horizontal alignment of the selected objects.
- Select **Left Edges** to move the selected objects so their left edges are aligned. The object in the selection set with the leftmost edge does not move.
- Select **Centers** to move the selected objects so their centers are aligned horizontally. The object with the center closest to the horizontal center of the selection set does not move.

- Select **Right Edges** to move the selected objects so their right edges are aligned. The object in the selection set with the rightmost edge does not move.
- Select **Space Evenly** to produce consistent horizontal spacing between the left and right edges of the objects in the selection set. The left- and rightmost objects on screen do not move and the ones in between move left or right as needed.
- Select **Distribute Centers Evenly** to produce consistent on-center horizontal spacing between the objects in the selection set. The left- and rightmost objects on screen do not move and the ones in between move left or right as needed.

## ALIGN/DISTRIBUTE ALONG LINE



Select one or more objects, click the **Align/Distribute Along Line** edit button, then click on a line or line-based object to open the Align To Line dialog and specify how to align the selected objects relative to the line.

**Align/Distribute Along Line**  is available in all views for most CAD objects. For architectural objects, it is only available in plan view.

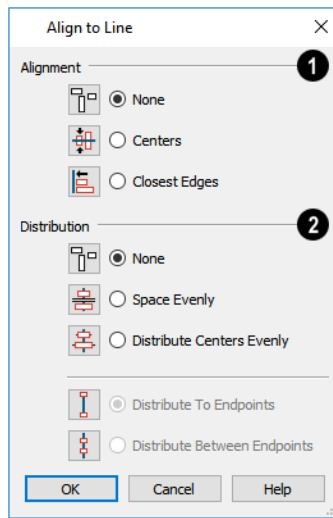

### 1 Alignment

Specify the **Alignment** to apply to the selected object(s) relative to the line.

- Select **None** to make no changes to the alignment of the selected objects.
- Select **Centers** to move the selected objects so their centers are aligned with the line.
- Select **Closest Edges** to move the selected objects so the edges closest to the line are aligned with the line.

### 2 Distribution

Specify the **Distribution** of the selected objects relative to the line.

- Select **None** to make no changes to the spacing of the selected objects.
- Select **Space Evenly** to produce consistent spacing between the edges of the objects in the selection set in the same direction as the line. The outermost objects in the group do not move and the ones in between move as needed.



- Select **Distribute Centers Evenly** to produce consistent on-center spacing in the same direction as the line between the objects in the selection set. The outermost objects in the group do not move and the ones in between move as needed.

Specify, too, how the first and last objects align with the line's endpoints. These options are only available if three or more objects are selected.

- Select **Distribute To Endpoints** to position the first and last objects in the array so they align with the line's endpoints.
- Select **Distribute Between Endpoints** to position the first and last objects in the array so inside the line's endpoints, spaced as though there were additional objects aligned with the endpoints.
- Select **None** to make no changes to the alignment of the selected objects.
- Select **Centers** to move the selected objects so their centers are aligned with the line.
- Select **Closest Edges** to move the selected objects so the edges closest to the line are aligned with the line.

## USING THE CROSSHAIRS

Objects can be aligned by eye using the mouse pointer crosshairs as a reference. This method can help you draw, place and edit objects quickly, easily, and with reasonable accuracy, but is not necessarily as accurate as some of the other approaches described here. See [Crosshairs on page 16](#).

The mouse pointer crosshairs can be turned on and off and their size and aperture set in the Preferences dialog. See [Edit Panel on page 115](#).

## USING SNAP SETTINGS



With **Object Snaps** on, you can snap the edge of a selected object to that of another. Select an edge of an object. Drag it to the edge of another object to reveal an Object Snap point, then release the mouse.



With **Grid Snaps** on and **Angle Snaps** off, select the left side of the object, and drag from the center move handle. This snaps the selected side to the grid.

When both **Grid Snaps** and **Angle Snaps** on, objects snap at increments equal to the **Snap unit** specified in the Plan Defaults dialog rather than onto the grid itself. This does not align objects to the grid unless they were already snapped to the grid. See [Snap Behaviors on page 159](#).

## USING DIMENSIONS



Create a temporary or manual dimension relative to an object such as a wall or line, and relocate the objects to the same dimension. See [Moving Objects Using Dimensions on page 483](#).



Text objects can be aligned using settings in the Text Specification dialog. See [Aligning Text on page 513](#).

## CAD STOPS MOVE/WALL STOPS MOVE

CAD and CAD-based objects can be aligned using another CAD object or a wall as a guide. Check the **CAD Stops Move** and/or **Wall Stops Move** boxes in the objects' specification dialogs, then move them until they bump into the CAD object or wall that you wish to use as a guide for alignment. See [Line Style Panel on page 305](#).

## MAKE PARALLEL/PERPENDICULAR

 The **Make Parallel/Perpendicular** edit button allows you to make a selected object parallel or perpendicular to any straight line or edge.

If you select an edge of a polyline-based object, adjacent edges extend or contract to maintain contact, but other edges remain unchanged. The selected edge rotates about its endpoint if selected near the end, or about its center if you click within its middle third.

The **Make Parallel** edit button displays for a selected CAD block instance when a line, including a straight polyline edge, or box edge within a block instance, straight polyline edge is selected. The entire block is rotated to make the selected line or edge perpendicular or parallel to the item subsequently clicked on.

A few objects, such as camera symbols, are not eligible to be used as an axis for the **Make Parallel/Perpendicular** tool.

### To use *Make Parallel/Perpendicular*

1. Select an object such as a roof plane on the edge that you would like to make parallel or perpendicular to another object.
  - Click near the center of the edge to rotate it about the center.
  - Click near an end to rotate the edge about that end.
2. Click the **Make Parallel/Perpendicular**  edit button.
3. Click on a straight edge of an eligible object such as a wall.
4. If the first object is within 45° of parallel to the second object, it is made parallel. Otherwise, it is made perpendicular to the second object.

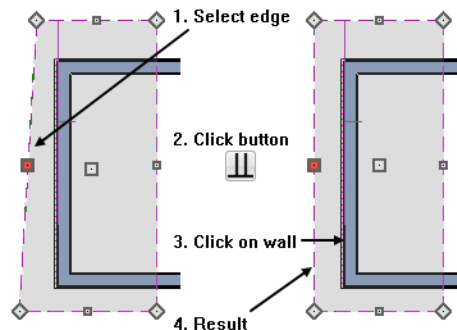

You can also make the selected edge parallel by rotating the entire object. See [Make Parallel/Perpendicular with Polyline-Based Objects on page 260](#).

## CENTER OBJECT

 The **Center Object** edit button can be used to center a variety of objects either relative to another object or between two points. Center Object can be used to center architectural objects in plan view, cross section/elevation, and 3D views. It can also be used to center CAD objects in plan view, cross section/elevation views, layout, and CAD Details.

A few objects, such as camera symbols, are not eligible to be used as a centering axis.

### ***To center an object***

1. Select an object.
2. Click the **Center Object**  edit button.
3. Move the mouse pointer over the object you would like to center the selected object relative to.
  - As the pointer passes over an eligible object, it becomes highlighted and a dashed centering axis line displays.
4. When the desired centering axis displays, click once to center the selected object along that axis line.

### ***To center an object in a room***

1. Select an object such a cabinet.
2. Click the **Center Object**  edit button.
3. Move the mouse pointer in the room that you would like to center the selected object relative to.
  - As you move the pointer, a centering axis will display along the wall it is closest to.
  - The selected object does not have to be inside a room in order to be centered relative to that room.
4. When a centering axis displays along the correct wall, click once.
5. The object is moved perpendicular to the centering axis.
  - As you move the pointer, a centering axis will display along the wall it is closest to.
  - The selected object does not have to be inside a room in order to be centered relative to that room.
6. When a centering axis displays along the correct wall, click once.
7. The object is moved perpendicular to the centering axis.

If you click outside an exterior wall instead of clicking inside, the selected object is centered along the edge of the Exterior Room. See *The Exterior Room on page 418*.





To retain a copy of the selected object(s) in the original location, the **Copy/Paste**  edit button before clicking the **Center Object** button. See *To use Copy/Paste with other edit tools on page 170*.

## **POINT TO POINT CENTER**



The **Point to Point Center** edit button can be used to center an object between two points.

### ***To center an object between two points***

1. Select an object and click the **Center Object**  edit button.
2. Click the **Point to Point Center**  edit button.
3. The mouse pointer displays the **Point A**  icon. Move the mouse pointer over one of the points you want to center the selection between and click once.
  - Object Snaps like the Center, Midpoint or Endpoint of an object can be used, although any point in the drawing area is valid. See *Object Snaps on page 160*.
4. An extension line extends from **Point A** to the mouse pointer, which now displays the **Point B**  icon.

5. When the mouse pointer is over the second centering point, click once more.
6. When the two centering points are defined, a set of temporary CAD points are created, identifying the points that the selected object can be moved to.
  - When the extension line is either horizontal or vertical, two CAD points are created.
  - If the line is angled, five CAD points are created.
7. Move your mouse pointer over a CAD point and click one more time to move the selected object to that location.

To retain a copy of the selected object(s) in the original location, the **Copy/Paste**  edit button before clicking the **Point to Point Center Object** button. See *To use Copy/Paste with other edit tools on page 170*.

## MAKE ARC TANGENT

-  If a selected arc is attached on one or both ends to another line or arc, the **Make Arc Tangent** edit button displays. Click this button to adjust the arc and attached lines so they transition smoothly.

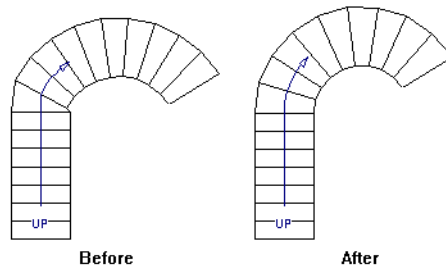

### To use Make Arc Tangent

1. Select an arc-based object attached to like objects on one or both ends.
2. Click the **Make Arc Tangent**  edit button.
  - If the arc is attached to an object on one end, it will adjust so that it is tangent to that object.
  - If the arc is attached to objects on both ends, the Radius of Tangent Arc dialog opens.

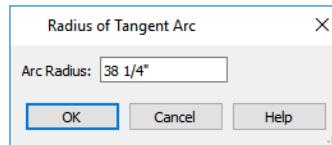

3. The radius from the center of curvature to the middle of the arc-based object displays.
  - If the arc is attached to an object on one end, it will adjust so that it is tangent to that object.
  - If the arc is attached to objects on both ends, the Radius of Tangent Arc dialog opens.

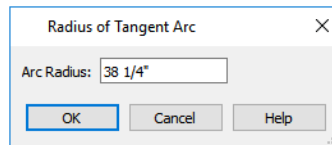

4. The radius from the center of curvature to the middle of the arc-based object displays.



- If the objects attached to each end of the arc are parallel to one another, this value displays for reference only.
  - Keep this radius or change it, and click **OK**.
5. The arc and attached segments adjust so that the arc radius matches the target as closely as possible and the arc is made tangent to the attached segments.

## ALIGNING ARC CENTERS

The center points of circles and arc-based objects can be aligned, even if the objects are on different floors, when the Reference Display is turned on and **Arc Centers and Ends**  is toggled on. Note that Arc Centers and Ends is a floor-specific toggle. See *The Reference Display on page 738* and *Arc Centers and Ends on page 223*.

To align center points easily, it is helpful to turn on **Object Snaps**  and turn off **Angle Snaps** . See *Object Snaps on page 160* and *Angle Snaps on page 162*.

## ALIGNING OBJECTS ON DIFFERENT FLOORS

Objects on different floors can be aligned with one another using **Object Snaps**  and the **Reference Display** . See *Object Snaps on page 160* and *The Reference Display on page 738*.

---

# Resizing Objects

Objects can be resized using the edit handles, specification dialogs, and the Transform/Replicate Object dialog.

## USING THE EDIT HANDLES

Depending on the currently active **Edit Behavior** , the end, corner and/or side edit handles can be used to resize a selected object. See *Defaults, Preferences, and Edit Behaviors on page 206*.

When the **Concentric**  edit behavior is active, dragging an object's corner or end handle resizes it according to the **Concentric Jump** value set in the Preferences dialog. See *Concentric on page 208*.

Objects can be resized about either their center points or the current CAD point. See *Rotate/Resize About on page 259*.

To override any movement restrictions caused by snap settings or the presence of other objects, press the Ctrl key while dragging an edit handle.

As an object is resized, any dimensions indicating its size will update to reflect your changes. You can use dimensions as references to help you achieve the correct size for most objects.

You can temporarily slow the movement of your mouse as you drag an edit handle by holding down the Shift key on your keyboard.

## USING THE SPECIFICATION DIALOG

 Most objects can be accurately resized in their specification dialogs. Some objects, such as images and some symbols, have a Retain Aspect Ratio option that lets you easily resize the object without distorting its shape. See *Specification Dialogs on page 21*.

## USING DIMENSIONS

-  Many objects can be resized by selecting an edge and then moving that edge using dimensions. See [Moving Objects Using Dimensions on page 483](#).

Walls can also be resized using dimensions; however, it is important to understand that the selected edges of other objects cannot be resized using dimensions - they can only be moved. To resize an edge, select an adjacent edge and move that edge instead.

## USING THE TRANSFORM/REPLICATE OBJECT DIALOG

-  Most objects can be resized about either their centers or an absolute point using the Transform Replicate Object dialog. See [Transform/Replicate Object Dialog on page 266](#).

---

# Reshaping Objects

There is a variety of ways to reshape objects using the edit handles, specification dialogs and edit toolbar buttons.

Some objects, notably circles and box-based objects, cannot be reshaped - only resized. See [Resizing Objects on page 253](#).

## USING THE EDIT HANDLES

Depending on the **Edit Behavior**  in use, the end, corner and/or side edit handles can be used to reshape a selected object. See [Defaults, Preferences, and Edit Behaviors on page 206](#).

When a line-based, arc-based, or open polyline-based object is selected, you can right-click and drag an end handle to change a line into an arc or vice versa. This behavior does not apply to closed polylines.

To override any movement restrictions caused by snap settings or the presence of other objects, press the Ctrl key while dragging an edit handle.

You can temporarily slow the movement of your mouse as you drag an edit handle by holding down the Shift key on your keyboard.

## USING THE SPECIFICATION DIALOG

-  A variety of CAD and CAD-based objects can be reshaped by editing values on either the SELECTED LINE or SELECTED ARC panel of their specification dialogs. See [Polyline Specification Dialog on page 317](#).

## USING DIMENSIONS

-  Both temporary and manually drawn dimensions can be used to increase or decrease the distance between the edge a line- or polyline-based object and another, parallel edge or line. See [Moving Objects Using Dimensions on page 483](#).

**Angular Dimensions**  can be used to adjust the angle where two polyline segments meet. See [Using Angular Dimensions on page 260](#).

## ADD BREAK







-  The **Add Break** edit tool can be used to break an individual line-, arc-, or spline-based object into two segments. The edges of a polyline-based object can also be broken.

The **Add Break** edit tool can also be used to create stepped cross section cutting planes. See [Stepped Cutting Planes on page 1092](#).

Note: The Add Break edit button is not available for box-based objects, objects created with the Circle Tools, North Pointers, Sun Angles, Joist Direction Lines, or some architectural objects such as stairs and trusses.

There are two types of breaks: partial and complete. A partial break creates a new corner or pivot point between two connected segments, while a complete break actually severs an edge into two disconnected segments.

### ***To create a partial break***

1. Select the object, object edge, or the centerline of the object that you want to add a pivot point or corner to.
2. Click the **Add Break**  edit button once or press the 3 key.
3. If you would like to create more than one break, click the **Sticky Mode**  edit button.
4. If you would like to move the edges of the object as you add breaks, click the **Edge Edit Handles**  edit button to toggle on their display.
5. If you want, you can click the **Corner Edit Handles**  edit button to toggle off their display.
6. Click the edge to create a new corner edit handle at that location and two separate edges on either side of that handle.
7. If you enabled **Sticky Mode** , continue clicking to place additional breaks.
8. Click the **Main Edit Mode**  edit button or press the Esc key to return to the selected object's main edit toolbar.





If you click and drag one of the edit handles on either side of the partial break, the edge moves at a right angle to itself and another edge forms, connecting the moved edge with the one on the other side that does not move.



You can remove an edge from a polyline-based object by clicking and dragging a corner handle until it snaps to an adjacent corner handle.

When a complete break is created, the object or edge is totally severed at that point.

With the exception of framing members, complete breaks cannot be created on CAD-based architectural objects. In the case of framing members, only complete breaks can be created.

### ***To create a complete break***



1. Click the object, object edge, or object centerline that you want to break into two segments.
2. Click the **Add Break**  edit button.
3. Click the **Complete Break**  edit button.
4. If you would like to create more than one complete break, click the **Sticky Mode**  edit button.
5. If you would like to move the edges of the object as you add breaks, click the **Edge Edit Handles**  edit button to toggle on their display
6. If you want, you can click the **Corner Edit Handles**  edit button to toggle off their display.
7. Click on an edge to create a complete break at that location.

- If you enabled **Sticky Mode** , continue clicking to place additional breaks.
- Click the **Main Edit Mode**  edit button or press the Esc key to return to the selected object's main edit toolbar.

The edge that you clicked on will be divided into two separate sections, one of which will be selected. You can now move or edit the selected edge completely independent of the object or edge on the other side of the break. Click on the other edge to select it instead.

When **Object Snaps**  are enabled, breaks can be placed at snap locations such as midpoints. See [Object Snaps on page 160](#).

### To remove a break from an edge

- Make sure that **Object Snaps**  are enabled. See [Object Snaps on page 160](#).
- Select the object that has a break that you want to remove.
- Click on the corner edit handle associated with the break that you want to remove and drag it to an adjacent corner handle.
- When you see an **Endpoint**  snap indicator, release the mouse button. The handle that you selected will be removed.

## CHANGE LINE/ARC

 Select an individual line-based or arc-based object or a segment of a polyline-based object and click the **Change Line/Arc** edit button to convert the selected segment from a line to an arc or vice versa.

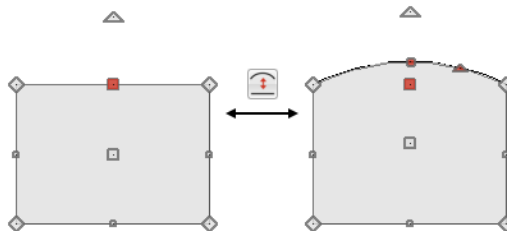

## USING MAKE PARALLEL/PERPENDICULAR

 The **Make Parallel** edit button can be used to reshape a polyline by making a selected edge parallel or perpendicular to another straight edge. See [Make Parallel/Perpendicular on page 250](#).

## INTERSECT/JOIN TWO LINES

 The **Intersect/Join Two Lines** edit tool allows you to connect two non-parallel line- and/or arc-based objects or to join two edges of an open or closed polyline-based object. The lines or edges will shorten or lengthen as need to intersect at a point and join. If one or more edges exists between the two polyline edges, they will be removed.

### To use Intersect/Join Two Lines

- Click on a line, arc, or polyline segment that you would like to connect to another line or segment.
- Click the **Intersect/Join Two Lines**  edit button.



3. Click on the other line or polyline edge.
4. If there are intervening polyline edges, a message will confirm that you would like them to be removed. Click **Yes**.

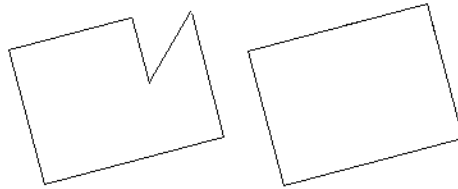



## FILLET LINES





 The **Fillet Lines** edit tool allows you to replace the angled corner where two polyline edges meet with an arc.

Fillet Lines can also be used to join two non-parallel line-based objects with an arc. If one or both of the two objects is an arc, both will extend or contract as needed to become connected. No additional arc is created.

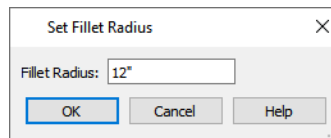
### To use Fillet Lines

1. Click on a line or polyline segment that you would like to connect to another line or segment with a fillet, or arc.
2. Click the **Fillet Lines**  edit button, then click the **Fillet Radius**  edit button.
3. In the Set Fillet Radius dialog, specify the desired **Fillet Radius** and click OK. If this value is 0, no fillet will be created.



4. To apply the specified radius to all corners of a selected polyline, click the **Fillet All Corners**  edit button. If the selected polyline is a Custom Countertop or Molding Polyline, any corners that touch a wall will not be filleted by this tool.
5. To apply a fillet to more than one corner of the selected polyline, click the **Sticky Mode**  edit button.
6. Click on the line or polyline segment that you want the selected line or edge to connect to with a fillet.
7. If you enabled **Sticky Mode** , continue clicking on edges to create additional fillets.
8. Click the **Main Edit Mode**  edit button or press the Esc key to return to the selected object's main edit toolbar.

Once two lines are filleted, the arc between them can be edited. See [Editing Arc-Based Objects on page 219](#).

## CHAMFER LINES

 The **Chamfer Lines** edit tool allows you to create a straight corner bevel of a specified size connecting any two non-parallel lines or polyline edges. The Chamfer Distance set in the Chamfer Distance dialog describes the distance both lines that form the corner are shortened to produce the bevel: not the length of the bevel itself.

The Chamfer Lines tool can also be used to extend an arc so that it joins to another arc or line. If one or both of the two objects is an arc, both will extend or contract as needed to become connected. No additional chamfer is created.

The Chamfer Lines edit tool is used much the way the Fillet Lines edit tool is. See [To use Fillet Lines on page 257](#), above.

 The Fillet Lines and Chamfer Lines edit tools can also be used the same way as the Intersect/Join Two Lines tool to join lines and polyline edges and remove any intervening polyline edges.

## USING CLOSE POLYLINE



An open polyline-based object can be converted into a closed polyline using the **Close Polyline** edit tool. See [Close Polyline on page 228](#).

## SIMPLIFY POLYLINE



The **Simplify Polyline** edit button is available for an open or closed polyline or polyline-based object with a segment that is unusually short and can cause problems when editing the polyline's shape. Click this edit button to remove the segment.

## CONVERT CURVE TO POLYLINE



The **Convert Curve to Polyline** edit button allows you to convert a selected arc- or circle-based object or object edge to a polyline composed of line segments. Not available for some architectural objects such as walls or stairs.

### *To convert curve to polyline*

1. Select an arc-based object or circle.
2. Click the **Convert Curve to Polyline**  edit button.
3. In the Convert Curve to Polyline dialog, specify the number of sides you would like the converted arc or circle-based object to have.

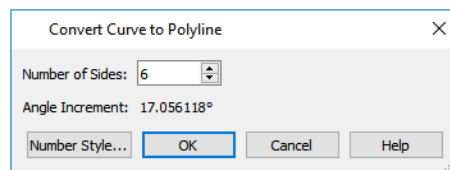

- The initial values in this dialog may vary depending on the type of object selected.
- Click **OK** to convert the selected arc or circle-based object into a polyline with the specified number of edges.

## CONVERT TO SPLINE



CAD polylines, most 3D Solids, as well as some CAD-based objects such as Slabs can be converted to splines or spline-based objects using the **Convert to Spline** edit tool. See [Editing Spline-Based Objects on page 235](#).

Unlike polylines, splines form smooth curves rather than angled corners where their direction changes. See [Splines on page 324](#).

Line- and arc-based objects cannot be converted to splines, nor can polylines with one or more curved edges.

## USING UNION, INTERSECTION, SUBTRACT



Closed polyline-based objects, including Primitives, can be used to create new shapes using the **Union**, **Intersection** and **Subtract** edit buttons. See [Union, Intersection, and Subtraction on page 274](#).

## Rotating Objects

Objects can be rotated using the edit handles as well as a variety of edit tools. Multiple selected objects can also be rotated as a group. See [Selecting Objects on page 210](#).

By default, an object or group of objects rotate about the center point of the selection set. You can instead specify that objects rotate about the current CAD point. See [The Current Point on page 298](#).

### USING THE EDIT HANDLES

Select an object, then click the triangular **Rotate** edit handle and drag it in any direction. When your pointer is over the Rotate handle, it displays a curved arrow .

The angles of line-based objects can also be changed by dragging an end handle in a direction other than parallel to the object. The object rotates about the opposite end point. See [Editing Line-Based Objects on page 216](#).

When **Angle Snaps**  are enabled, objects snap to Allowed Angles as specified in the Plan Defaults dialog as they are rotated. See [Angle Snaps on page 162](#).

To override any movement restrictions caused by snap settings or the presence of other objects, press the Ctrl key while dragging an edit handle.

You can temporarily slow the movement of your mouse as you drag an edit handle by holding down the Shift key on your keyboard.

### USING THE SPECIFICATION DIALOG

 The exact angle of some objects such as lines, arcs, walls and the selected edges of polylines can be specified on either the GENERAL panel, SELECTED LINE panel, or SELECTED ARC panel of that object's specification dialog. See [Polyline Specification Dialog on page 317](#).

### ROTATE/RESIZE ABOUT

 Objects can be rotated about either their own centers or the current CAD point. See [The Current Point on page 298](#).

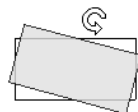

Rotate About Object Center



Rotate About Object Center

You can specify which behavior is used by selecting **Edit> Edit Behaviors> Rotate/Resize About Current Point** .

When this option is selected, objects rotate about the current CAD point; when it is not selected, object rotate about their centers.

The Rotate/Resize About behavior can also be specified in the Preferences dialog. See [Behaviors Panel on page 118](#).

### ENTERING COORDINATES

Objects can be rotated by entering coordinates or a distance and angle in the Enter Coordinates dialog. See [Entering Coordinates on page 166](#).

## USING ANGULAR DIMENSIONS

 **Angular Dimensions** are useful for adjusting the angles of a variety of objects with straight edges. See [Angular Dimensions on page 470](#).

### To change an angular dimension

1. Draw an **Angular Dimension**  between the objects you want to move.
  - Begin and end as close as possible to the two objects you wish to locate.
2. Select the edge that you want to move.
3. Click the dimension value to open the Set Angular Dimension dialog.
  - The **Previous Value** is indicated degrees, minutes and seconds.

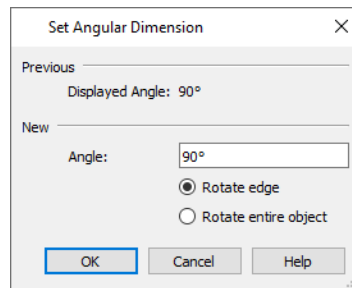

4. Enter a value in the **New Value** field.
5. Select **Rotate Edge** to move the selected edge when OK is clicked or select **Rotate entire polyline** to rotate the entire object the selected edge is a part of, maintaining the Previous Value of the angle.
6. Click **OK** to apply the change.

When an entire polyline is rotated using the Set Angular Dimension dialog, it rotates around the vertex of the angle.

## MAKE PARALLEL/PERPENDICULAR WITH POLYLINE-BASED OBJECTS

 The **Make Parallel/Perpendicular** edit button usually adjusts the angle of a selected polyline edge. See [Make Parallel/Perpendicular on page 250](#).

To rotate the entire polyline instead, double-click the **Make Parallel**  edit button to open the Make Parallel dialog.

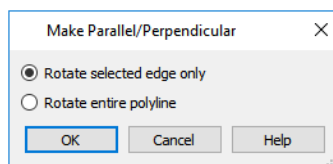

Choose to either **Rotate Selected Edge Only**, or **Rotate Entire Polyline**. This setting is global, affecting all files, and is retained during the current program session.

Polylines rotate according to the current **Rotate/Resize About** setting. See [Behaviors Panel on page 118](#).

## USING THE TRANSFORM/REPLICATE OBJECT DIALOG

 Objects and groups of objects can be rotated to a relative or absolute angle using the Transform Replicate Object dialog. See [Transform/Replicate Object Dialog on page 266](#).

## USING MULTIPLE COPY

 A rotated array of copies of the selected object(s) can be created using the **Multiple Copy** edit tool. See *To create an array of copies on page 172*.

---

# Reflecting Objects

There are several ways to reflect an object, group of objects, or an entire plan about an axis or another object. Either the original object(s) or copies of the original(s) can be reflected.

## REFLECT ABOUT OBJECT

 A selected object or objects can be reflected about another object, regardless of its angle, using the **Reflect About Object** edit tool.

Line-based objects are often used for reflecting a selection, but most objects have an axis that can be used.

- When an open or closed polyline-based object is used as the reflective object, the edge that is clicked on acts as the axis.
- When a circle or box-based object such as a CAD box or cabinet is used as the reflective object, the axis runs down the center of the object from back to front.
- In 3D views, architectural objects can only be reflected about a vertical axis - not a horizontal axis.
- A few objects, such as camera symbols, are not eligible to be used as a reflective object.

### *To use Reflect About Object*

1. Draw a CAD line to act as the reflection line.
2. Select the object(s) to be reflected.
3. Click the **Reflect About Object**  edit button.
4. Move your mouse pointer over a CAD line, object edge, or other object that you would like to reflect the selection about.
5. When the mouse pointer is over a valid reflection axis, a preview of the selection to be pasted will display on the opposite side of the axis as the original.
6. Click once when the preview meets your needs. The selection is reflected around the CAD line, and the original is no longer there.

To retain a copy of the selected object(s) in the original location, click the **Copy/Paste**  edit button before clicking the **Reflect About Object** button. See *To use Copy/Paste with other edit tools on page 170*.

## USING TRANSFORM/REPLICATE OBJECT

 Objects and groups of objects can also be reflected horizontally or vertically using the Transform Replicate Object dialog. See *Transform/Replicate Object Dialog on page 266*.

## REVERSE DIRECTION

 Select a line-based, arc-based, open spline-based, or open polyline-based object and click the **Reverse Direction** edit button to reverse its direction. Not available for Terrain Path objects.

Reversing an object's direction switches its Start and End points and can be useful with certain line styles or if the selected object has an arrow at one end. The **Reverse Direction** tool also reverses the direction in which a selected Walkthrough Path is recorded. See [Walkthrough Paths on page 1207](#).

## REVERSE PLAN

 The **Reverse Plan** tool reflects architectural and CAD objects on all floors of an entire plan, as though they were flipped about a vertical line. See [Reverse Plan on page 147](#).

Note: Reverse Plan does not affect the Terrain objects. See [Terrain on page 1243](#).

---

# Converting Objects

CAD objects and many CAD-based objects can be converted into a variety of other types of objects.

## CAD TO WALLS

 **CAD to Walls** allows you to convert a 2D line drawing into a 3D model. Double CAD lines and arcs drawn to represent wall layers and other structural items can be converted to actual Chief Architect walls, railings, windows, or doors. See [CAD to Walls on page 383](#).

## CAD DETAIL FROM VIEW

 Select **CAD > CAD Detail from View** to create a CAD drawing of the current view. See [CAD Detail from View on page 338](#).

**CAD Detail from View** does not truly convert objects in the current view into CAD objects; instead, it creates a copy of the original view composed of CAD objects instead of architectural objects, leaving the original view intact.

## CONVERT POLYLINE

 The **Convert Polyline** edit tool lets you turn CAD objects into CAD-based architectural objects such as countertops and stair landings, special polylines such as Materials List Polylines, and a variety of slab, hole and terrain objects.

To convert a CAD object into one of these 3D objects, select the object and click the **Convert Polyline**  edit button to open the Convert Polyline dialog.

If the selected CAD polyline contains any holes, those holes will be converted to holes in the converted object, when appropriate. See [Polyline Holes on page 232](#).

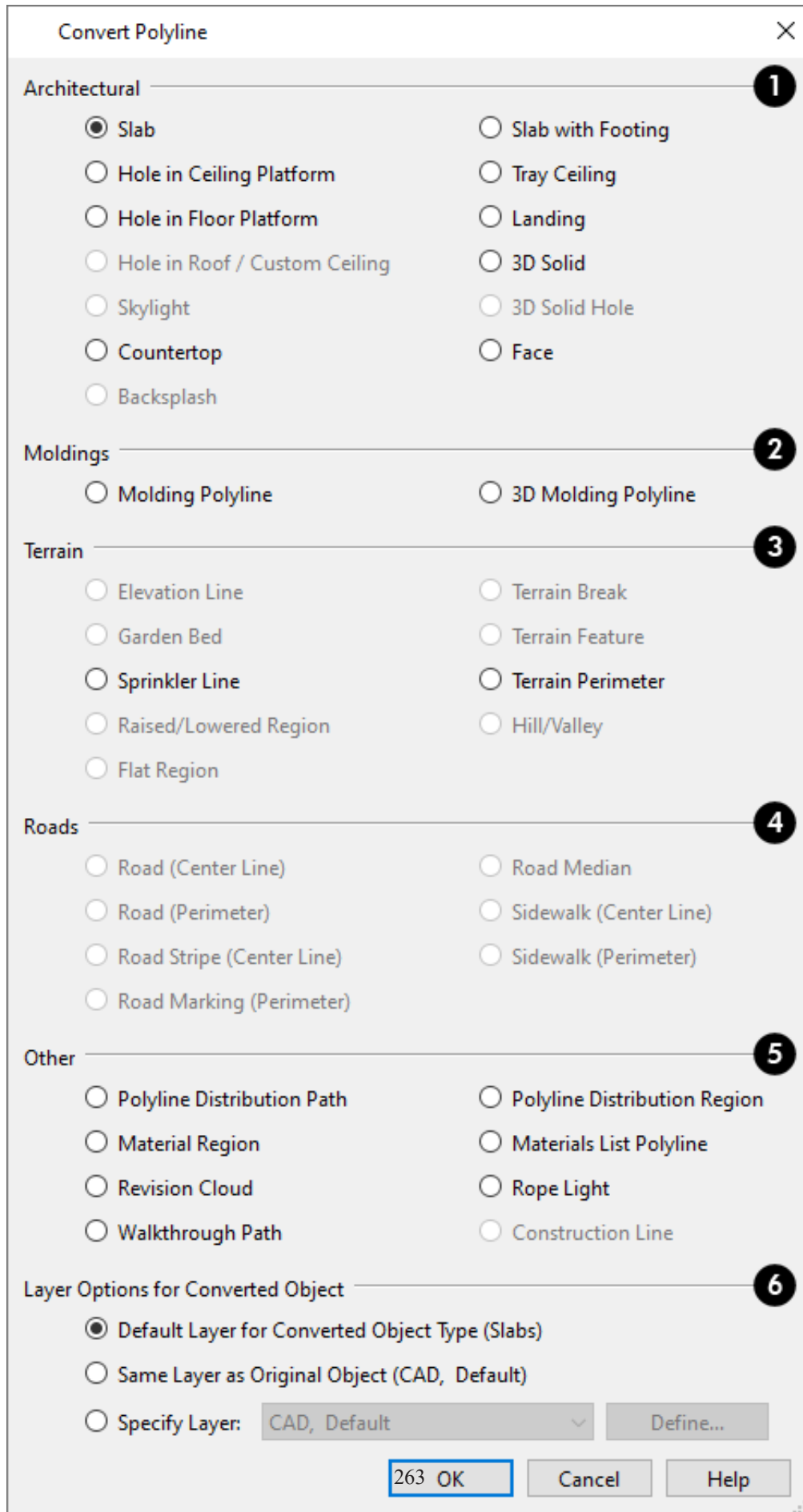

Click the radio button beside one of the objects in this dialog, then click OK. The options that are available will depend on whether a plan view is active or a cross section/elevation view.

## 1 Architectural

The **Architectural** settings are only available if the selected polyline is closed. See *Polylines on page 316*.

- **Slab and Slab with Footing** - See *The Slab Tools on page 719*.
- **Hole in Ceiling Platform** - Only available when the selected polyline is contained inside a single ceiling platform. See *Floor and Ceiling Platforms on page 428*.
- **Hole in Floor Platform** - Only available when the selected polyline is contained inside a single floor platform.
- **Hole in Roof/Custom Ceiling** - Only available when the selected polyline is contained inside a single roof plane or ceiling plane. See *Skylight/Roof Hole Specification Dialog on page 835*.
- **Tray Ceiling** - See *Tray and Coffered Ceilings on page 430*.
- **Countertop** - See *Countertops on page 627*.
- **Landing** - Not available if the polyline is a spline. See *Landings on page 755*.
- **3D Solid** - See *3D Solid on page 1015*.
- **3D Solid Hole** - See *3D Solid Feature on page 1017*.
- **Backsplash** - Only available in cross section/elevation views. See *Floor and Wall Material Regions on page 1037*.

## 2 Moldings

- **Molding Polyline** - See *Molding Polylines on page 935*.
- **3D Molding Polyline** - See *3D Molding Polyline on page 936*.

## 3 Terrain

Most of the **Terrain** options are only available when a Terrain Perimeter is present.

- **Elevation Line** - See *Elevation Lines on page 1248*.
- **Garden Bed** - Only available when the selected object is a closed polyline. See *Terrain Features on page 1252*.
- **Sprinkler Line** - See *Sprinkler Tools on page 1301*.
- **Raised/Lowered Region** - Only available when the selected object is a closed polyline. See *Terrain Modifier Tools on page 1251*.
- **Flat Region** - Only available when the selected object is a closed polyline. See *Terrain Modifier Tools on page 1251*.
- **Terrain Break** - See *Elevation Data Tools on page 1246*.
- **Terrain Feature** - Only available when the selected object is a closed polyline. See *Terrain Features on page 1252*.
- **Terrain Perimeter** - See *Terrain Perimeter on page 1244*. This option is only available when: the polyline is closed, a terrain perimeter does not yet exist, and only one polyline is currently selected.
- **Hill/Valley** - Only available when the selected object is a closed polyline. See *Terrain Modifier Tools on page 1251*.

## 4 Roads

The **Roads** options are only available when a terrain perimeter is present. See *Road Tools on page 1285* and *Sidewalk Tools*



on page 1286.

- **Road (Perimeter)** - Only available when the selected polyline is closed.
- **Road (Center Line)** - Convert to a road where the polyline represents the center line of the road.
- **Road Median** - This is helpful for creating medians on curved roads.
- **Road Marking (Perimeter)** - Convert to a road marking where the polyline represents the perimeter of the road marking. Only available when the selected polyline is closed.
- **Road Stripe (Center Line)** - Convert to a road stripe where the polyline represents the center line of the road stripe.
- **Sidewalk (Perimeter)** - Convert to a sidewalk polyline where the polyline represents the perimeter of the sidewalk. Only available when the selected polyline is closed.
- **Sidewalk (Center Line)** - Convert to a sidewalk where the polyline represents the center line of the sidewalk.

## 5 Other

- **Walkthrough Path** - See *Walkthrough Paths on page 1207*.
- **Material Region** - See *Floor and Wall Material Regions on page 1037*.
- **Materials List Polyline** - Only available when the selected object is a closed polyline. See *Materials List Polylines on page 1322*.
- **Revision Cloud** - Only available when the selected object is a closed polyline. See *Revision Clouds on page 321*.
- **Construction Line** - Only available when the selected object is composed of a single line segment. See *Construction Lines on page 65*.

## 6 Layer Options for Converted Object

The **Layer Options for Converted Object** let you control which layer the selected object is on once converted. See *Layers on page 176*.

- Select **Default Layer for Converted Object Type** to put the object on the default layer for its type. That layer is reported in parentheses for reference.
- Select **Same Layer as Original Object** to keep the object on the same layer it was on before it was converted. That layer is also reported for reference.
- Select **Specify Layer** to select the desired layer from the drop-down list.
- Click the **Define** button modify the attributes of the selected layer. See *Layer Display Options Dialog on page 179*.

Click **OK** to convert the object or objects.

The specification dialog appropriate to the newly converted object opens, allowing you to specify its height, material and other information.

## CONVERT TO PLAIN POLYLINE



Click the **Convert to Plain Polyline** edit button to convert a special polyline-based object to a plain 2D CAD polyline. See *Polylines on page 316*.

When a special polyline is converted into a plain polyline, it is placed on the Current CAD Layer, and it can be converted into a special polyline of the same or different type.

Bear in mind that some special polylines such as Custom Backsplashes can only be converted to a plain polyline in the view type that they were created in. If a special polyline is selected and converted in a 3D view, the resulting plain polyline will be created in plan view.

### CONVERT TO SOLID



Click the **Convert To Solid** edit button to convert the selected object into a Primitive object, or solid, so that it can be used with other solids to create complex structures. See *Primitive Tools on page 1015*.

### CONVERT TO SYMBOL



Create a 3D view of a custom object, then select **Tools> Symbol> Convert to Symbol** to convert the object into a symbol. See *Convert to Symbol on page 1002*.

### CONVERT TO SPLINE



Click the **Convert to Spline** edit button to convert CAD polylines as well as some CAD-based objects such as Slabs to spline-based objects. See *Editing Spline-Based Objects on page 235*.

Unlike polylines, splines form smooth curves rather than angled corners where their direction changes. See *Splines on page 324*.



### CONVERT SPLINE TO POLYLINE



Click the **Convert Spline to Polyline** edit button to convert the selected spline-based object into a polyline.

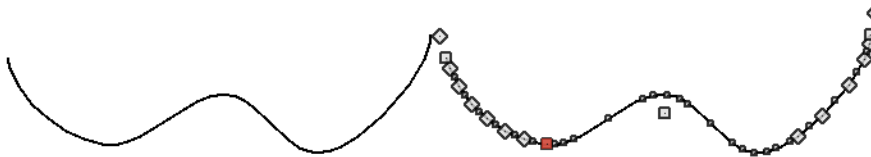

A curved portion in a spline is represented as a number of smaller straight lines. You can change a spline into a normal polyline that is made up of these straight lines using this edit tool.

---

## Transform/Replicate Object Dialog

 Select any object or group of objects and click the **Transform/Replicate Object** edit button to open the **Transform/Replicate Object** dialog.

If multiple options are selected in the Transform/Replicate Object dialog, they are performed in the order they appear in the dialog, from top to bottom.

 Always double-check values entered in the Transform/Replicate Object dialog. Large offset values, resize factors, or numbers of copies can result in objects that are time-consuming to create or may be off the screen.

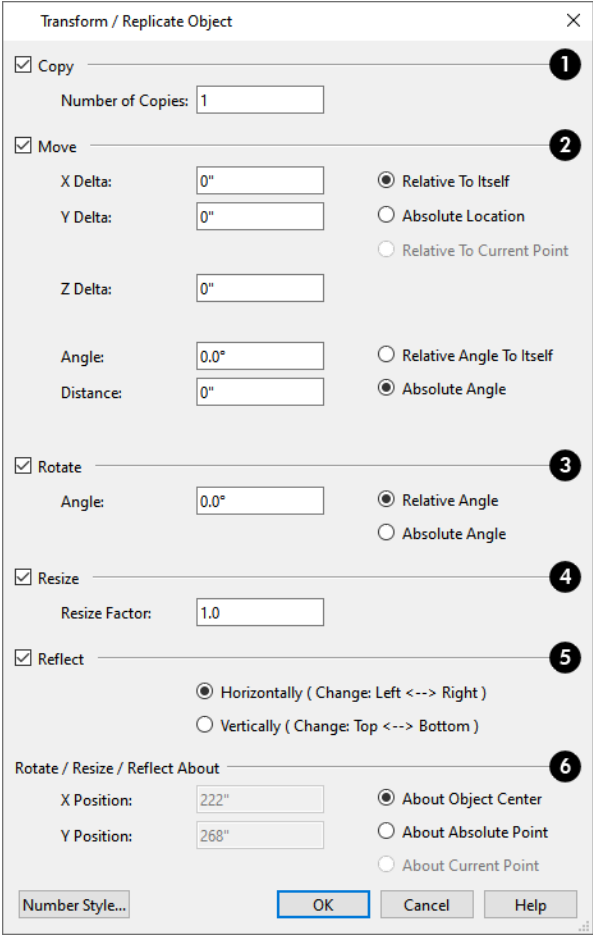

**1 Copy**

Check **Copy**, then specify the **Number of Copies** to make.

**2 Move**

Check **Move**, then specify how far and in what direction to move the selected object(s).

There are three ways to define where you want to move the selection in the horizontal XY plane:

- Specify the desired **X Delta** and **Y Delta** values, which are the object’s changes in position along the X and Y axes. Only available when the **Relative to Itself** or **Relative to Current Point** radio button is selected as the movement reference. See *The Current Point on page 298*.
- Specify the desired **X Position** and **Y Position** values, which define a point along the X and Y axes. Only available when **Absolute Location** is selected as the movement reference. See *3D Drafting on page 13*.

- Specify the **Angle** of movement and the **Distance** that you want the selection to move.
- Select **Relative Angle to Itself** to move the selection relative to its current orientation. When this option is selected, the selection's current absolute orientation is reported in the Angle field and can be changed.
- Select **Absolute Angle** to move the selection relative to an imaginary horizontal line drawn in the positive X direction from the origin.



When the X/Y Delta or X/Y Position settings are changed, the information in the Angle and Distance fields will update automatically, and vice versa.

You can also specify the **Z Delta**, which is the selection's elevation on the vertical Z axis. This setting is always relative to the selection's original elevation.

### 3 Rotate

Select this option, then specify the **Angle** to rotate the object(s).

- Select **Absolute Angle** to rotate the object relative to an imaginary horizontal line drawn in the positive X direction from the origin.
- Select **Relative Angle** to rotate the object the specified angle relative to its current orientation.

You can also specify the point the selected object(s) rotate about, below.

### 4 Resize

Specify the **Resize Factor** in decimals. A resize factor of 2 doubles the size of the object, while a resize factor of 0.5 halves the object's size. Not available for all objects, including line- and arc-based objects and Primitives.

You can also specify the point the selected object(s) is resized about, below.

### 5 Reflect

Select this option, then specify which axis to reflect about.

- **Horizontally** - Select this option to reflect the object horizontally.
- **Vertically** - Select this option to reflect the object vertically.

You can also specify the point the selected object(s) is reflected about, below.

### 6 Rotate/Resize/Reflect About

This section is enabled when the **Rotate**, **Resize** and/or **Reflect** functions are selected.

- **X Position** - Specify the X coordinate of the point to perform the selected edit function(s) about when **About Absolute Point** is selected.
- **Y Position** - Specify the Y coordinate of the point to perform the selected edit function(s) about when **About Absolute Point** is selected.
- **About Object Center** - Select this option to perform the selected edit function(s) about the object's center.
- **About Absolute Point** - Select this option to perform the selected edit function(s) about the specified point.
- **About Current Point** - Select this option to perform the selected edit function(s) about the current CAD point.

---

## Edit Area Tools

-  The **Edit Area Tools** allow you to quickly define an area of your plan and select the objects in that area. Once selected, they can then be repositioned, copied or deleted. Select **Edit> Edit Area** to access the **Edit Area Tools**.

Unlike other selection methods, the **Edit Area Tools** cut walls, railing and fencing where the selection marquee intersects them, allowing you to edit only the selected portion of these objects.

Some objects, such as cabinets, are included in the selection only if more than half of the object is contained within the marquee.

Camera and cross-section/elevation symbols are included in the selection and can be moved with it. While cameras can also be rotated as well as copied, cross section/elevations cannot. See *Editing 3D Views on page 1105*.

A few objects, notably CAD points, are not affected by the **Edit Area Tools**.



The Edit Area tools can cause wide-spread changes across an entire plan and should always be used with caution.

### EDIT AREA

-  Select **Edit> Edit Area> Edit Area** and draw a rectangular marquee around the area of the plan to be edited.

**Edit Area** affects all objects included in the selection marquee that are located on the current floor, regardless of whether they are displaying in plan view or not.

### EDIT AREA VISIBLE

-  Select **Edit> Edit Area> Edit Area Visible** and draw a marquee around the area of the plan to be edited.

**Edit Area Visible** only affects visible objects included in the selection marquee: objects not currently displayed in plan view are unaffected.

### EDIT AREA (ALL FLOORS)

-  Select **Edit> Edit Area> Edit Area (All Floors)** and draw a marquee around the area of the plan to be edited.

**Edit Area (All Floors)** affects all objects on all floors of the plan that are included in the selection marquee, regardless of whether they display in plan view.

### EDIT AREA (ALL FLOORS) VISIBLE

-  Select **Edit> Edit Area> Edit Area (All Floors) Visible** and draw a marquee around the area of the plan to be edited.

**Edit Area (All Floors) Visible** affects all visible objects on all floors of the plan that are included in the selection marquee. Objects not currently displaying in plan view are not affected.

### EDIT AREA POLYLINE

If a rectangular marquee's shape does not allow you to define an area precisely, use a closed polyline instead.

Select a polyline that defines the desired area in plan view and then select one of the **Edit Area Tools** . The polyline becomes temporarily highlighted and acts as an Edit Area marquee.

## USING THE EDIT HANDLES

An Edit Area marquee displays edit handles that are similar to those of a closed polyline. See *Using the Edit Handles on page 228*.

- Click the **Move** edit handle to move the entire selection set. See *Moving Objects on page 243*.
- Click the **Rotate** edit handle to rotate the entire selection set. See *Rotating Objects on page 259*.
- Click and drag the **Reshape** and **Resize** edit handles at each corner and along each edge to adjust the size and shape of the marquee. See *Using the Edit Handles on page 228*.

Adjusting the size or shape of an Edit Area marquee may change which objects are included in the selection set but does not otherwise affect those objects.

## USING THE EDIT TOOLBAR

A selected Edit Area marquee and/or the objects within it can be edited in a variety of ways using the buttons on the Edit Toolbar. See *Using the Edit Toolbar on page 230*.

The following toolbar buttons may display on the Edit Toolbar for an Edit Area marquee:



**Copy/Paste** copies the selection set to the system clipboard so it can be pasted elsewhere. See *Copying and Pasting Objects on page 167*.



**Delete** deletes the selection set. See *Deleting Objects on page 284*.



**Transform/Replicate Object** copies, moves, rotates, resizes, or reflects the selection set. See *Transform/Replicate Object Dialog on page 266*.



**Multiple Copy** makes a series of copies of the selection set at regular intervals. Concentric copies are not possible using the Edit Area tools. See *Multiple Copy on page 172*.



**Make Parallel/Perpendicular** rotates the Edit Area marquee and the selection set so that the selected marquee edge is parallel or perpendicular to another straight edge. See *Make Parallel/Perpendicular on page 250*.



**Point to Point Move** accurately moves the selection between two points. See *Point to Point Move on page 245*.



**Center Object** centers the selection relative to another object. See *Center Object on page 250*.



**Reflect About Object** reflects the selection set about another object. See *Reflecting Objects on page 261*.



**Allowed Angles** opens the Place at Allowed Angles dialog.

## PLACE AT ALLOWED ANGLES DIALOG



If more than one percent of the straight walls included in an Edit Area marquee are not at an Allowed Angle, the **Allowed Angles** edit button displays.

Click the **Allowed Angles** edit button to display the Place at Allowed Angles dialog.

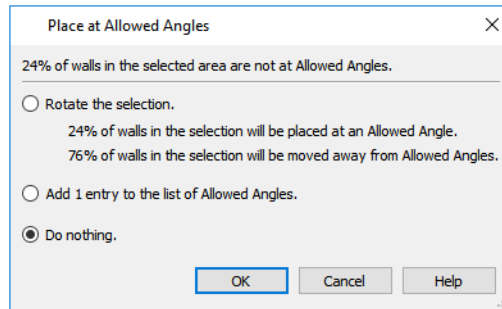

Select the first option and click **OK** to rotate the plan so that the largest group of off-angle walls move to an Allowed Angle. This may place this largest group at Allowed Angles, but has two disadvantages.

- First, other groups of off angle walls remain off angle.
- Second, any walls that were at an allowed angle before this action will move to an off angle. The dialog shows how much (weighted by length) of the selected walls are in each category.

Select the second option and click **OK** to add new entries to the Allowed Angles list and allow new walls to be placed at these angles. Walls already at Allowed Angles remain so. See [Angle Snaps on page 162](#).

Select the third option and click **OK** to do nothing, which is the same as clicking **Cancel**.

You may want to rotate the majority of the walls to one of the normal allowed angles. Then, use an **Edit Area**  tool to select everything again and select the second option to provide new angle entries to cover the remaining walls.

## Stretch CAD

 The **Stretch CAD** tool allows you to reshape or move a variety of CAD-based objects using a temporary closed polyline.

### *To use the Stretch CAD tool*

1. Select **Edit> Stretch CAD** .
2. Click and drag to draw a rectangular polyline through the CAD objects that you would like to stretch.
3. You can edit the shape of the Stretch CAD polyline so that it intersects the objects you want to stretch along the desired planes. See [Editing Closed Polyline-Based Objects on page 228](#).
  - An edge of the polyline must extend through each of the objects that you would like to stretch.
  - The opposite polyline edge should be located outside those objects.
4. When the Stretch CAD polyline's shape and position meet your needs, click and drag its Move edit handle.
5. As you drag, intersected objects will either stretch, contract, or move.
  - An edge of the polyline must extend through each of the objects that you would like to stretch.
  - The opposite polyline edge should be located outside those objects.
1. When the Stretch CAD polyline's shape and position meet your needs, click and drag its Move edit handle.
2. As you drag, intersected objects will either stretch, contract, or move.

Not all CAD-based objects can be reshaped using the **Stretch CAD**  tool:

- Road and Text objects are examples of objects that can be moved but not reshaped by this tool.
- Stairs, Ramps, and Sun Shadows are examples of objects that are not affected by this tool at all.

## Trim and Extend

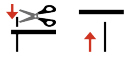

The **Extend Object(s)** and **Trim Object(s)** edit tools allow you to use the edge of a selected CAD-based object as a baseline for lengthening or shortening a variety of other CAD objects and framing members. See

[Editing Framing on page 882](#).

When either the **Extend Object(s)** or **Trim Object(s)** edit button is clicked, its edit mode is enabled and three new edit buttons display on the Edit Toolbar:



**Sticky Mode** allows you to remain in the current mode and edit multiple objects or select multiple fences.



Click the **Select Fence** edit button, then click on an object to use it as a fence for selecting objects to either trim or extend. See [Using a Fence on page 215](#).



**Main Edit Mode** or the Esc key returns you to the selected object's main edit toolbar. If **Sticky Mode** is enabled when you click this button, it will still be enabled if you click either the **Extend Object(s)** or **Trim Object(s)** edit button after returning to the Main Edit Mode.

Note: Trim Objects and Extend Objects cannot be used to modify closed polyline-based objects. See [Editing Closed Polyline-Based Objects on page 228](#).

### TRIM OBJECTS



Lines, arcs, open polylines, circles and framing items can be trimmed. The trimming, or cutting, object may be any CAD-based object, a group of CAD objects, or even a CAD block. Select the trimming object(s) and click the **Trim Object(s)** edit button.

The **Trim Object(s)** edit tool can be used in three different ways:

- Individually clicking on objects to be trimmed.
- Selecting objects to be trimmed using a fence. See [Using a Fence on page 215](#).
- Selecting objects to be trimmed using a temporary fence.



#### *To trim by clicking*

1. Draw the cutting line(s) or polyline(s) through the objects to be trimmed.
2. Select the cutting line(s) and click the **Trim Object(s)** edit button.
3. Click the **Sticky Mode** edit button if you wish to click multiple objects to trim them.
4. Click each segment intersected by a cutting line one-by-one to trim it back to the cutting line.



#### *To trim using a fence*

1. Draw the cutting line(s) or polyline(s) through the objects to be trimmed.
2. Draw a fence through the object segments to be trimmed. Be sure that the fence intersects the objects on the side of the cutting line(s) that you want to edit. See [Using a Fence on page 215](#).



3. Select the cutting line(s) and click the **Trim Object(s)**  edit button.
4. Click the **Sticky Mode**  edit button if you wish to trim objects using multiple fences.
5. Click the **Select Fence**  edit button.
6. Click the fence(s) to trim the object segments intersected by the fence.

### ***To trim using a temporary fence***

1. Draw the cutting line(s) or polyline(s) through the objects to be trimmed.
2. Select the cutting line(s) and click the **Trim Object(s)**  edit button.
3. Click the **Sticky Mode**  edit button if you wish to trim objects using multiple temporary fences.
4. Click and drag a temporary line to act as a fence, trimming the object segments intersected by it. Be sure to draw this fence on the side of the cutting object(s) that you wish to edit.



## **EXTEND OBJECTS**

 Lines, arcs, open polylines, and framing items can also be extended to any CAD-based object, group of CAD objects, or CAD block.



As with Trim Objects, there are three ways to use **Extend Objects**:

- Individually clicking on objects to be extended.
- Selecting objects to be extended using a fence.
- Selecting objects to be extended using a temporary fence.



### ***To extend by clicking***

1. Draw the boundary line(s) or polyline(s) you want the objects to extend to.
2. Select the boundary line(s) and click the **Extend Objects**  edit button.
3. Click the **Sticky Mode**  edit button if you wish to extend multiple objects.
4. Click an object that you would like to extend to the boundary line(s).

### ***To extend using a fence***

1. Draw the boundary line(s) or polyline(s) you want the objects to extend to.
2. Draw a fence through the objects to be extended. See [Using a Fence on page 215](#).
3. Select the boundary line(s) and click the **Extend Objects**  edit button.
4. Click the **Sticky Mode**  edit button if you wish to extend objects using multiple fences.
5. Click the **Select Fence**  edit button.
6. Click the fence to extend the objects segments intersected by the fence until they meet the boundary line(s).

### *To extend using a temporary fence*

1. Draw the boundary line(s) or polyline(s) you want the objects to extend to.
2. Select the boundary line(s) and click the **Extend Objects**  edit button.
3. Click the **Sticky Mode**  edit button if you wish to extend objects using multiple temporary fences.
4. Click and drag a temporary line to act as a fence, trimming the object segments intersected by it.

---

## Union, Intersection, and Subtraction



New closed polyline-based objects of varying shapes can be created based on the shapes of existing closed polyline-based objects using the **Union**, **Intersection** and **Subtraction** edit tools. See [Editing Primitives and 3D Solids on page 1017](#).

The type of object that gets created by a Union, Intersection, or Subtraction operation depends on the types of objects that were involved in that operation:

- If the original objects are of the same type, the new object that is created will also be of that same type.
- If the initially selected object is a CAD polyline and other objects are not, the resulting object will be a CAD polyline.
- If the objects are of different types and a CAD polyline is not the initially selected object, the new object will be a 3D Solid.

Note: The Union Intersection and Subtraction edit tools are not available for objects specified as holes, such as Slab Holes or Custom Countertop Holes.

### UNION



Use the **Union** edit button to combine two or more closed polylines or solids into a single object.

The following example shows three closed polylines and the single polyline that results when the three are merged using the **Union** edit button.

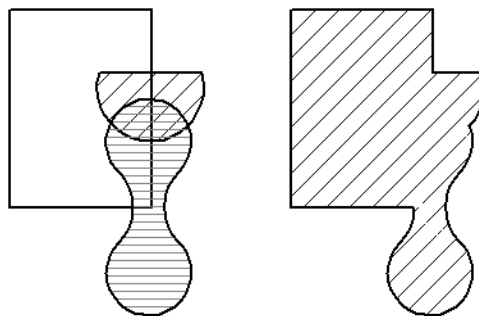

Three separate closed polylines merges into a single object

There are two methods of combining closed polylines or solids using the **Union** edit button: the single selection and group selection methods.

Begin by creating two or more overlapping objects of the same type. If one object is a countertop, for example, the others should be countertops, as well.

If the original objects do not overlap, they will either not produce a new object or will be duplicated on top of themselves.

***To use the single selection method***

1. Select a single closed polyline or solid object.
2. Click the **Union**  edit button.
3. Click another closed polyline or solid.
4. If the object is a polyline, a message box will let you choose to either retain or delete the original objects.
5. A new polyline of the same type as the originals is created and is selected. Its shape is defined by the boundaries of the original objects. If the original objects were retained, it is superimposed over them and can be moved.

***To use the group selection method***

1. Group-select two or more closed polylines or solid objects.
2. Click the **Union**  edit button.
3. If the object is a polyline, choose to retain or delete the original objects in the dialog that opens.
4. A new object of the same type as the originals is created, is selected, and is superimposed over the originals if they were retained.

This second method allows you to combine more than two polylines simultaneously.

Note: If the original objects do not overlap, the Union edit tool duplicates them and then either deletes or retains the originals.

**INTERSECTION**

 Use the **Intersection** edit button to create a single polyline based on the overlap area of two or more closed polyline-based objects or solids.

The following shows two polylines and the single polyline that results when the **Intersection** edit tool is used.

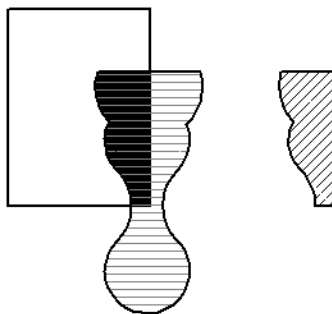

A single polyline is created based on the space where two polylines overlap

There are two methods of combining closed polylines or solids using the **Intersection** edit button: the single selection and group selection methods. The second method allows you to work with more than two objects simultaneously.

Begin by creating two or more overlapping objects of the same type. If one object is a countertop, for example, the others should be countertops, as well.

If the original objects do not intersect, no new object is created.

***To use the single selection method***

1. Select a single closed polyline or solid object.
2. Click the **Intersection**  edit button.
3. Click another closed polyline or solid.
4. If the object is a polyline, choose to retain or delete the original objects in the dialog that opens.
5. A new object of the same type as the originals is created and is selected. Its shape is defined by the area shared by the original objects and, if the originals were retained, it is superimposed over them and can be moved.

***To use the group selection method***

1. Group select two or more closed polylines or solid objects.
2. Click the **Intersection**  edit button.
3. If the object is a polyline, choose to retain or delete the original objects in the dialog that opens.
4. A new object of the same type as the originals is created, is selected, and is superimposed over the originals if they were retained.

**SUBTRACTION**

 Use the **Subtraction** edit button to subtract the area of one object that overlaps another object of the same type to create a third, new object.

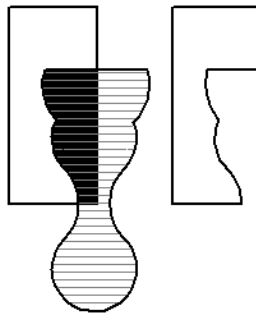

A new polyline is created when the area defined by two overlapping polylines is deleted from one of them

There is one method for using the **Subtraction** edit button.



***To use the Subtraction edit tool***

1. Draw two or more closed polyline-based objects or solids that overlap. One object can be completely enclosed by another.
2. Select the object or objects that you want to **remove** a portion from.
3. Click the **Subtraction**  edit button and then click the unselected object that defines the area you want to remove.
4. When prompted, choose to retain or delete the original objects in the dialog that opens.
5. A new object of the same type as the originals is created, is selected, and is superimposed over the originals if they were retained.

Note: If the original objects do not overlap, the Subtraction edit tool duplicates the first object selected and then either deletes or retains it.

## Eyedropper and Painter Tools

There are a number of tools in Chief Architect that allow you to apply attributes to objects by clicking on them.

- The Eyedropper tools allow you to load attributes from one object and apply them to other objects.
- The Painter tools allow you to apply attributes to one or more objects. Depending on the tool, attributes may be loaded from another object using an Eyedropper tool or selected from a dialog.
- Some object attributes can also be replaced directly from the library. See *To replace an inserted object on page 976*.
- The **Match Properties**  and **Apply Properties**  edit tools allow you to apply attributes from a selected object to other objects. See *Matching Properties on page 282*.

Attributes cannot be either loaded from or painted onto objects on locked layers or on layers that are not set to display. They can be used to modify automatically generated objects such as roof planes and framing; however, the associated Auto Rebuild function will be turned off. See *Auto Rebuild on page 166*.

### EYEDROPPER TOOLS

The Eyedropper tools allow you to select attributes from one object and apply them to other objects. There are four Eyedropper tools in the program:



**Material Eyedropper**, see *Material Eyedropper on page 1053*



**Object Eyedropper**, see *Object Eyedropper on page 282*







**Fill Style Eyedropper**, see *Fill Style Eyedropper and Painter Tools on page 192*



**Layer Eyedropper**, see *Layer Painter, Eyedropper, and Hider on page 188*





### *To use an eyedropper tool*

1. Select the Eyedropper tool that you want to use and notice that the mouse pointer displays an eyedropper  icon.
2. Move the mouse pointer over an object in the current view. If the object is eligible for use with the selected Eyedropper:
  - It will become highlighted in the view.
  - The left side of the Status bar will report information about that object or the attribute that the Eyedropper can load from it.
3. Click once to load the object's attributes so they can be applied to other, similar objects.
4. Notice that your mouse pointer now displays a spray can  icon. This means that the Painter tool associated with the selected Eyedropper is now active.
5. Depending on the tool in use, additional buttons may now display on the Edit Toolbar. Select the option or options that you need:

- The **Painter Scoping Mode** buttons. See *Painter Scoping Modes on page 278*, below.
  - **Blend Colors with Materials**. See *Material Painter Tools on page 1052*.
  - **Select Properties to Paint** . See *Object Eyedropper on page 282*.
  - **Toggle Library Replacement Mode** . See *Replace From Library on page 976*.
6. Move your mouse pointer over an object that is similar to the one selected in step 2. If it is eligible to receive the loaded attribute(s):
    - It will become highlighted in the view.
    - The left side of the Status bar will report information about the attribute to be painted or loaded.
  7. Click on an eligible object to apply the specified attributes to it as well as to any other identical objects, depending on which Painter Scoping Mode is active.
  8. Continue clicking to apply attributes until the Esc key is pressed or another tool is activated.

## PAINTER TOOLS

The Painter Tools let you apply attributes to a wide variety of objects by clicking on them. When a Painter tool is active, the mouse pointer will display a spray can  icon. There are a number of ways to load attributes into a Painter tool.

- Click on an object using any Eyedropper tool to load its attribute(s). The associated Painter tool will become active, ready to paint the loaded attributes.
- Select a material or fill style in the Library Browser and move the mouse pointer into the current view window. If that item can be applied in the current view type, the associated Painter will be active and you can apply the selection to eligible objects in that view.
- When you select the **Material Painter**  tool, the Select Material dialog will open, allowing you to choose a material from the library. See *Select Material/Library Object Dialog on page 1056*.
- When you select the **Fill Style Painter**  tool, the Select Library Object dialog will open, allowing you to choose a fill style from the library. See *Select Library Object Dialog on page 974*.
- When you select the **Layer Painter**  tool, the Select Layer dialog will open, allowing you to choose a layer. See *Select Layer Dialog on page 186*.
- When you activate the Object Painter, click the **Select Properties to Paint**  button to open the Select Properties to Load dialog and select the attributes that you want to apply to other objects. See *Matching Properties on page 282*.
- When you select a Style Palette in the User Catalog of the Library Browser, the Style Painter tool will become active, ready to paint the specified attributes. See *Style Palettes on page 279*.

Once a Painter tool is loaded, simply click on an object to apply the selected attributes. See *To use the Material Painter tool on page 1053*.

## PAINTER SCOPING MODES

There are five Painter Scoping Modes that control how broadly or narrowly a selected Painter tool will apply an attribute or attributes to objects in the current plan. These modes are listed in the same submenu as the associated Eyedropper and/or Painter tool. When a Painter tool is active, they are also found on the Edit Toolbar. In both locations, a small check mark will display at the lower left of the active Mode's button icon.



Depending on the type of object attributes have been loaded from, not all Object Painter Scoping Modes may be available. The Layer Painter does not have scoping modes: it always paints individual target objects one at a time.

Rather than modify instances of an object type, the Material Painter Scoping Modes replace instances of a material based on the selected scope.



**Object Mode** applies attributes to or replaces a material on individual target objects, one at a time. All instances of the original material on a target object are replaced by the one being painted.



**Marquee Mode** is available in plan view for the Style Palette Painter, Fill Style Painter, and Object Painter tools. In addition, it is available in CAD Detail views for the Fill Style and Object Painter tools. To use this mode, click and drag a marquee around the objects you would like to paint instead of clicking on them.



**Room Mode** applies attributes to a target object as well to all instances of that object type in the same room with a single click. All instances of the original material throughout the room are replaced by the one being painted.



**Floor Mode** applies attributes to a target object as well as all instances of that object type on the same floor with a single click. All instances of the original material on the current floor are replaced by the one being painted.



**Plan Mode** applies attributes to a target object as well as all instances of that object type in the entire plan with a single click. All instances of the original material throughout the plan are replaced by the one being painted.



An additional mode, the **Component Mode**, is only available for the Material Painter and Adjust Material Definition tools. It is also available when replacing an inserted object with another from the library. See [Material Painter Scoping Modes on page 1053](#), [Adjust Material Definition on page 1058](#), and [Replace From Library on page 976](#).

Chief Architect will remember your Painter Scoping Mode selection until you quit the program. The next time you launch the program, Object Mode will be active.

---

## Style Palettes

A **Style Palette** is a collection of object properties that you can use to quickly change the appearance of doors, windows, cabinets, Custom Countertops and Backsplashes, any of these objects included in Architectural Blocks, and/or rooms in a plan as a group. These objects are referred to collectively as Style Palette Objects. Style Palettes can potentially modify a large number of object properties, allowing you to make considerable changes to a plan's appearance very quickly. They can be used in plan view, but are particularly effective in camera views.

Style Palettes are saved in the library, making them available for use in any plan. See [Adding Library Content on page 965](#).

### To use the Style Painter

1. Select a Style Palette in the Library Browser. See [Assigned Items on page 974](#).
2. Move your mouse pointer into the active plan or camera view window and notice that it displays a spray can  icon.
3. Select the desired Painter Scoping Mode:



**Object Mode** applies relevant properties to an individual Style Palette Object.



**Marquee Mode** applies relevant properties to Style Palette Objects located inside a marquee that you draw in plan view.



**Room Mode** applies relevant properties to all Style Palette Objects in a room.



**Floor Mode** applies relevant properties to all Style Palette Objects on the current floor level.



**Plan Mode** applies relevant properties to all Style Palette Objects in the current plan file.

4. Apply the properties of the selected Style Palette to objects in the current plan:
5. If you selected Marquee Mode, click and drag a rectangular marquee around the objects you that would like to apply the selected Style Palette's properties to.
6. For all other Painter Scoping Modes, click on a door, window, cabinet, Custom Countertop, Custom Backsplash or room surface to apply properties according to the active Painter Scoping Mode.

## CREATING A STYLE PALETTE

There are three ways to create a Style Palette:

- Select a door, window, cabinet, any combination of these objects, or a room, and click the **Add Object(s) to Style Palette**  edit button. In the Add to Style Palette dialog, click the **Create New** button. A new Style Palette with the selected objects loaded into it is created. The **Add Object(s) to Style Palette** edit button is also available in the contextual menu for Style Palette Objects in the Library Browser. See *Using the Contextual Menu on page 951*.
- Right-click on the User Catalog or a folder within it and select **New> Style Palette** from the contextual menu. A new, blank Style Palette is created.
- You can also create a copy of an existing Style Palette in the library and then customize it.

## USING STYLE PALETTES

In order to apply a particular property using a Style Palette, two conditions must be met:

- The object saved in the Style Palette must have that property set in its specification dialog. The easiest way to do this is to select an object that has the desired attributes and then click the **Add Object(s) to Style Palette** edit button.
- The Style Palette must be set to apply that property when the Style Painter is used.

You can make changes to both the properties of a Style Palette's objects and which of those properties will be applied using the Style Painter in the Style Palette Dialog.

While most object properties are eligible to be applied using Style Palettes, a few are not, for example: waterfall edges on Custom Countertops. In addition, interior and exterior door properties are only applied to doors of the same Type as the one in the selected Style Palette.

## STYLE PALETTE SPECIFICATION DIALOG

 To open the Style Palette Specification dialog, right-click on a Style Palette in the User Catalog and select **Open Object** from the contextual menu. This dialog also opens when you create a new Style Palette or add an object to a Style Palette.



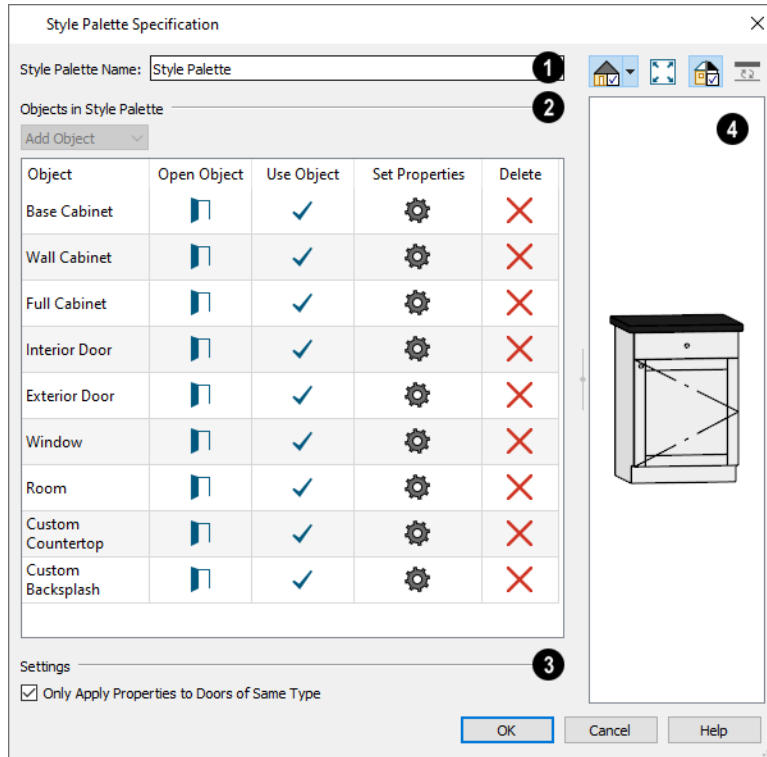

### 1 Style Palette Name

Type a short, descriptive **Style Palette Name** in the text field.

### 2 Objects in Style Palette

The **Objects in Style Palette** are listed in a table and can be managed here.

- Select an object type from the **Add Object** drop-down list. When all Style Palette Objects are already represented in the Style Palette, this option will not be available.
- Select an item in the **Object** column to display it in the preview pane to the right.
- Click in the **Open Object** column to open the specification dialog for the object in that row and make changes to its properties. See [Specification Dialogs on page 21](#).
- When a check mark is present in the **Use Object** column for an object, its properties will be applied to objects of the same type when the Style Painter is used. When no check mark is present, objects of that type are unaffected when the Style Painter is used. Click in this column to add or remove the check mark for any of the objects in the table.
- Click in the **Set Properties** column to specify which of the associated object's properties are assigned to objects when the Style Painter is used. See [Select Properties to Load Dialog on page 283](#).
- Click in the **Delete** column to remove the object in that row from the Style Palette. A replacement can be added using the Add Item drop-down list if you wish.

### 3 Settings

- When **Only Apply Properties to Doors of Same Type** is checked, door properties are only applied to doors of the same type as that added to the selected Style Palette. If the selected Style Palette's door is a Sliding door, for example, only Sliding doors will be affected when this Style Palette is used. Uncheck this box to apply door properties to doors of all types. See *Door Tools on page 545*.

### 4 Preview

A preview of the selected Style Palette Object displays on the right side of the dialog. See *Dialog Preview Panes on page 22*.

---

## Matching Properties

A variety of attributes can be copied from one object to another using the Object Painter tools. In addition, the Match Properties and Apply Properties tools allow you to identify and select similar objects, as well as copy attributes from one object to another.

### OBJECT EYEDROPPER



Select **Tools > Object Painter > Object Eyedropper** to apply the attributes of one object to other objects. The Object Eyedropper functions like other Eyedropper tools. See *To use an eyedropper tool on page 277*.

When the Object Painter is active, you can specify which attributes are loaded by clicking the **Select Properties to Paint**  edit button. You can also choose a Painter Scoping Mode to control how broadly or narrowly the selected attributes are applied to other objects. See *Painter Scoping Modes on page 278*.

### MATCH PROPERTIES



The **Match Properties** edit tool allows you to quickly select all objects in the current view that share the same set of specified attributes as the selected object. This tool is available in plan view and CAD Details only.

### APPLY PROPERTIES



The **Apply Properties** edit tool can be used to apply the selected attributes to any other objects in the current view that do not yet share them.

**Apply Properties** becomes available only after the **Match Properties** edit tool has been used to select a group of objects sharing the same attributes.

#### *To use the Match and Apply Properties tools*

1. In plan view or a CAD Detail, select an object with attributes that you would like to apply to other like objects in the current view.
2. Click the **Match Properties**  edit button.
3. In the Match Properties dialog, check the box beside each attribute that you want to apply to other similar objects and click OK. See *Select Properties to Load Dialog on page 283*, below.
4. All objects sharing all of the specified attributes become selected.

5. Click the **Apply Properties**  edit button, then either:
  - Click on a like object that is not highlighted to apply the specified attributes to it and add it to the selection set.
  - Click and drag a rectangular selection marquee. Any like objects within its area will receive the specified attributes and be added to the selection set.
6. You can continue clicking on objects until the Esc key is pressed or another tool is activated.

## SELECT PROPERTIES TO LOAD DIALOG

 Select **Tools> Object Painter> Object Eyedropper**, click on an object, then click the **Select Properties to Paint** edit button.

 The settings in this dialog are also found in the Match Properties dialog. To open this version of the dialog, select an object and click the **Match Properties** edit button.

This dialog is also similar to the Set Properties dialog. To open this version, click a Set Properties button in the Style Palette Specification dialog. See [Style Palettes on page 279](#).

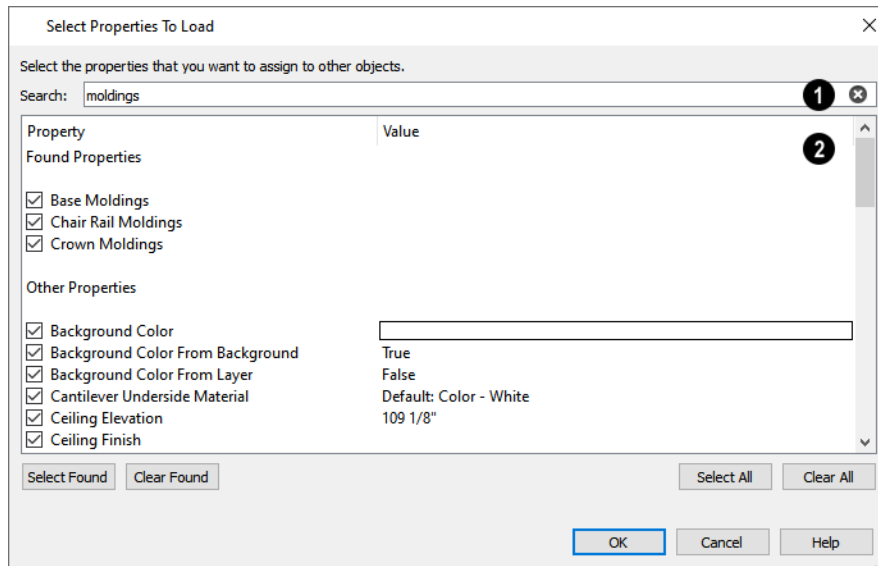

### 1 Search

Filter the attributes that display in the list below by typing in the **Search** field.

- When all or part of a keyword is typed in the Search field, this list is divided into two categories: Found Properties which match your Search criteria followed by the remaining Other Properties.
- Click the **Clear**  button on the right side of the Search field to remove anything typed in this field.

### 2 Properties

A list of the selected object's Properties and the associated Values displays here. The available Properties vary, depending on the type of object selected.

- Check the box beside a Property to apply its Value to similar objects. In the Match Properties dialog, checking boxes also allows you to select objects that share the same attributes when you click **OK**.
- Click the **Select All** button to select all Properties, regardless of whether they are shown in the list or filtered out.

- Click the **Clear All** button to deselect all Properties, regardless of whether they are shown in the list or filtered out.
- Line items can also be group-selected and then checked or unchecked together. See [Shift and Ctrl Select on page 214](#).

The **Select** and **Clear Transferrable** buttons are available in the Match Properties dialog only, and only when the Search field is empty, above.

- Click the **Select Transferrable** button to select all items that can be transferred to other objects. Non-transferrable properties are not selected.
- Click the **Clear Transferrable** button to deselect all items that can be transferred to other objects. Non-transferrable properties may remain selected.

The **Select** and **Clear Found** buttons are available when there is text in the Search field.



- Click the **Select Found** button to select all items shown in the search results.
- Click the **Clear Found** button to deselect all items shown in the search results.
- In the Set Properties dialog only, click the **Reset to Default** button to reset the selected attributes back to the defaults.

A few Properties can only be used for selecting objects and cannot be loaded from one object to another. These Properties display in the Match Properties dialog followed by an asterisk but do not display in the Select Properties to Load dialog at all.

---

## Deleting Objects

Objects can be deleted in a variety of ways:

- Select an object or group of objects, then: click the **Delete**  edit button; select **Edit> Delete**  from the menu; or press either the Delete or Backspace key on your keyboard.
- Entire categories of objects can be deleted using the Delete Objects dialog.
- Objects are deleted if the floor they are placed on is deleted. See [Deleting Floors on page 735](#).

If an object has a line with arrow attached to it, the line with arrow is deleted if the object is deleted. To prevent the arrow from being deleted, drag the attached end away from the object before deleting it.

A variety of objects in the program can be generated automatically, including roofs, the foundation, and framing. Automatically generated objects cannot be deleted unless the automatic creation option is disabled.



Objects such as roofs, framing, and Auto Exterior Dimensions that are set to automatically rebuild or refresh cannot be deleted while that behavior is enabled. Automatically generated objects cannot be deleted unless the automatic creation option is disabled.



Although objects on locked layers cannot be selected, most can nevertheless be deleted using the Delete Objects dialog.

### DELETING POLYLINE EDGES

There are a number of different ways to delete individual edges of polyline-based objects:

- Select **Connect CAD Segments** . Select the edge and delete. See *Disconnect Edges on page 212*.
- Drag a corner handle until it overlaps an adjacent corner handle to remove the edge between them and merge them into a single handle.
- Create a complete break at both ends. Select the edge and delete. See *To create a complete break on page 255*.
- The **Fillet Lines**  and **Chamfer Lines**  tools can be used to delete polyline edges. See *Reshaping Objects on page 254*.

## DELETE SURFACE



In any 3D view, select **3D> Delete Surface**, then click a surface in the view to temporarily remove the surface from the current view without permanently affecting the object. See *Delete 3D Surface on page 1099*.

---

## Delete Objects Dialog



The Delete Objects dialog lets you delete categories of objects in a plan or layout file. Select **Edit> Delete Objects** to access this dialog. The settings in the dialog vary depending on whether a plan or a layout file is active:

### IN PLAN VIEWS

The Delete Objects dialog only deletes objects in plan view - it does not delete CAD objects or schedules drawn in cross section/elevation views or CAD Details. If this dialog is opened while a camera view is active, CAD objects and schedules cannot be deleted.

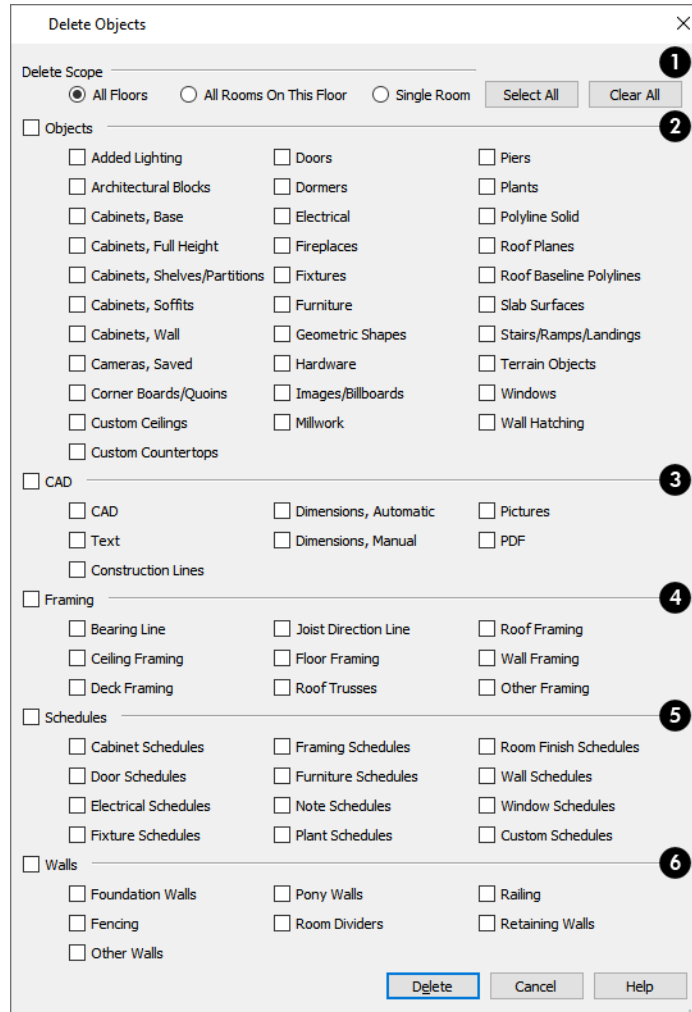

### 1 Delete Scope

- Choose **All Floors** to delete objects on all floors in the current plan.
- Choose **All Rooms on This Floor** to delete objects in all rooms on the current floor.
- Choose **Single Room** to delete objects only in rooms on the current floor that you specify.
- Click the **Select All** button to check all boxes in all categories.
- Click the **Clear All** button to uncheck all boxes.

### 2 Objects

Specify which types of architectural **Objects** you want to delete.

### 3 CAD

Specify which types of **CAD** objects you want to delete. See *CAD Objects on page 290*.

### 4 Framing

Specify which types of **Framing** objects you want to delete. See *Framing on page 850*.

## 5 Schedules

Specify which types of **Schedules** you want to delete. See *The Schedule Tools on page 682*.

## 6 Walls

Specify which kinds of **Walls** you want to delete. See *Walls, Railings, and Fencing on page 342*.

### *To use the Delete Objects dialog*

1. Specify the **Delete Scope** as **Single Room**, **All Rooms On This Floor**, or **All Floors**.
2. Click **Select All** to check all the boxes or **Clear All** to uncheck all boxes.
3. Check the box for each category of objects you want to delete.
  - Check the box beside any heading to select all of the categories within it; clear the box beside a heading to deselect all of its categories.
4. Check the box for each subcategory of objects that you want to delete.
  - If “Roof Planes” cannot be selected, they may be locked. See *Editing Roof and Ceiling Planes on page 808*.
5. When the scope is set to **Single Room**:
  - Move your cursor into the drawing area and click in a room of the plan to delete objects of the selected type within that room without closing the dialog.
  - Only objects with their center point located in the room are deleted.
  - Continue clicking on rooms or choose a different Delete Scope.
  - Click **Done** when all selections have been deleted.

Note: If you click in or try to switch to a view window other than the active view, the Delete Objects dialog will close.

6. If you select **All Rooms On This Floor** or **All Floors**, you do not need to click in plan view. The **Delete** button becomes available, and clicking it closes the dialog and deletes the specified objects.

## IN LAYOUT

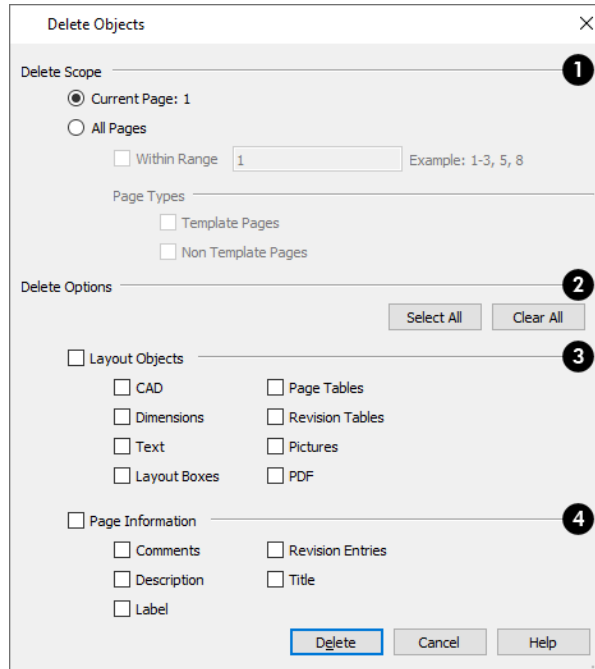

### 1 Delete Scope

- Choose **Current Page** to delete objects from the current page of the layout file.
- Choose **All Pages** to delete objects from all pages of the layout file and enable the additional scope options below.
- Check **Within Range** specify which pages to delete objects from, then specify the page numbers, separated by commas or by a dash.
- Specify which **Page Types** to delete objects from: check **Template Pages** to delete objects from Template pages, and/or, check **Non Template Pages** to delete objects from regular pages. See [Page Templates on page 1334](#).

### 2 Delete Options

- Click the **Select All** button to check all boxes in both categories.
- Click the **Clear All** button to uncheck all boxes.

### 3 Layout Objects

Specify which types of objects that you want to delete. See [On the Layout Page on page 1337](#).

### 4 Page Information

Specify the which types of Page Information that you would like to have cleared from the pages specified above. See [Layout Page Information on page 1358](#).



---

## Undo and Redo



The **Undo** and **Redo** commands allow you to both undo the last action performed, as well as redo actions that were recently Undone.

Undo files are stored in the Undo Directory, which can be specified in the Preferences dialog. See *Folders Panel on page 106*.

The 50 most recent actions can be Undone or Redone, depending on your settings in the Preferences dialog. See *General Panel on page 102*. Actions that can be Undone and Redone include creating, editing, and deleting objects as well as the Delete, Rename, and Copy actions in the Project Browser.

The maximum number of Undo files is specified in the **Maximum Undos** value in the Preference settings. If you have **Undo** enabled, be sure to define a directory on a hard drive with enough space for these files.

To Undo an action, select **Edit> Undo**, click the **Undo**  button, or press Ctrl + Z on your keyboard.

The Redo command is only available after Undo has been used. To Redo an Undone action, select **Edit> Redo**, click the **Redo**  button or press Ctrl + Y on your keyboard.

It is important to note that **Undo** and **Redo** do not affect all actions in the program, including:

- Save and Save As. See *Saving Plan and Layout Files on page 40*.
- Changes made in the Library Browser. See *The Library Browser on page 946*.
- Changes made in a dialog while the dialog box is open. See *Dialogs on page 19*.
- Changes made to lights using the Adjust Lights dialog. See *Adjust Lights Dialog on page 1140*.
- Changes made to Note Types in the Note Type Management dialog. See *Note Type Management Dialog on page 534*.
- Changes made to entries in the Time Log dialog. See *Time Log Dialog on page 61*.
- Changes made to the display by panning the display or zooming in or out. See *Zoom Tools on page 153*.
- Changes made to the position of a camera, or its Rendering Technique. See *Editing 3D Views on page 1105*.

# CAD Objects

## Chapter 10

The CAD tools allow you to add details to 2D views of your design to create complete working drawings. Custom details can be created, saved, and used in other plans.

CAD objects do not affect 3D objects or display in camera views or overviews, but they can be used to add details to layout pages, plan views and cross section/elevation views.

CAD polylines can be converted to 3D objects such as countertops and terrain data, and shown in 3D views. See [Convert Polyline on page 262](#).

CAD objects are edited much like other objects in Chief Architect. See [Editing Objects on page 205](#).

### TOPICS

<b>CAD Defaults and Preferences</b> .....	<b>291</b>
<b>The CAD Drawing Tools</b> .....	<b>295</b>
<b>Point Tools</b> .....	<b>296</b>
<b>Line Tools</b> .....	<b>300</b>
<b>Line Specification Dialog</b> .....	<b>304</b>
<b>Drawing Arcs - Arc Creation Modes</b> .....	<b>307</b>
<b>Arc Tools</b> .....	<b>309</b>
<b>Arc Specification Dialog</b> .....	<b>311</b>
<b>Circle Tools</b> .....	<b>314</b>
<b>Circle/Oval/Ellipse Specification Dialog</b> .....	<b>315</b>
<b>Polylines</b> .....	<b>316</b>
<b>Polyline Specification Dialog</b> .....	<b>317</b>
<b>Box Tools</b> .....	<b>319</b>
<b>Box Specification Dialog</b> .....	<b>320</b>
<b>Revision Clouds</b> .....	<b>321</b>
<b>Revision Cloud Specification Dialog</b> .....	<b>322</b>
<b>Splines</b> .....	<b>324</b>
<b>Displaying CAD Objects</b> .....	<b>325</b>
<b>Arrowheads</b> .....	<b>327</b>
<b>CAD Blocks</b> .....	<b>329</b>
<b>CAD Block Management</b> .....	<b>333</b>
<b>CAD Block Specification Dialog</b> .....	<b>334</b>
<b>CAD Details</b> .....	<b>337</b>
<b>CAD Detail Specification Dialog</b> .....	<b>338</b>
<b>Plot Plans and Plan Footprints</b> .....	<b>339</b>
<b>Plan Footprint Specification Dialog</b> .....	<b>340</b>

## CAD Defaults and Preferences



CAD Defaults can be accessed by selecting **Edit> Default Settings** from the menu and expanding the CAD category.



The behavior and appearance of CAD objects are also affected by settings on the CAD, LINE PROPERTIES, SUN ANGLE, BEHAVIORS, and SNAP PROPERTIES panels of the Preferences dialog. Unlike default settings, preference settings are global, affecting all plan and layout files. See [Preferences Dialog on page 95](#).

### REVISION CLOUD DEFAULTS

Settings in the Revision Cloud Defaults dialog determine the initial appearance of Revision Clouds. The settings in this dialog are similar to those in the Revision Cloud Specification dialog. See [Revision Cloud Specification Dialog on page 322](#).

**Revision Clouds** can support multiple Saved Defaults. In order to open the defaults dialog for this tool, you must first open its Saved Defaults dialog and choose an available saved defaults setup. See [Multiple Saved Defaults on page 79](#).

### CAD DEFAULTS DIALOG



The settings in the CAD Defaults dialog control the basic appearance of CAD objects. This dialog can also be opened by clicking the **CAD Defaults** button, which can be added to the toolbars. See [To add a button to a toolbar on page 132](#).

Each plan file has multiple CAD Defaults dialogs: one affecting each floor level in all plan views, one for every cross section/elevation view, and one for every CAD Detail and Wall Detail. Each layout file has its own CAD Defaults, as well. The CAD Defaults associated with a given view can be accessed by opening the CAD Defaults dialog while that view is active.

The CAD Defaults dialog cannot be opened when a camera view or overview is active.

Note: Although there are multiple CAD Defaults dialogs in each plan file, only one layer can be specified as the Current CAD Layer at any given time. When a new Current CAD Layer is selected, the change affects all views and view types.

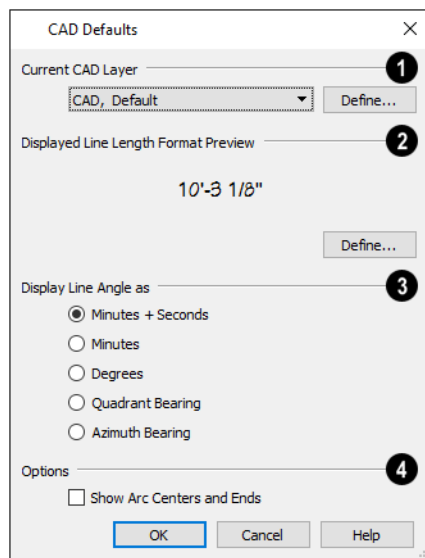

### 1 Current CAD Layer

Select the **Current CAD Layer** from the drop-down list. See *Current CAD Layer on page 326*.

- Click the **Define** button to open the Layer Display Options dialog. See *Layer Display Options Dialog on page 179*.

### 2 Displayed Line Length Format Preview

Line Length Indicators report the length of the edges of some CAD-based objects and only display when **Show Length** is checked in an object's specification dialog. See *Line Style Panel on page 305*.

- A preview of the format used by all Line Length Indicators in the current file displays here.
- Click the **Define** button to open the Displayed Number Style dialog and edit the Displayed Line Length format.

### 3 Display Line Angles as

Specify the format to use when **Show Angle** is checked in an object's specification dialog. See *Line Style Panel on page 305*.

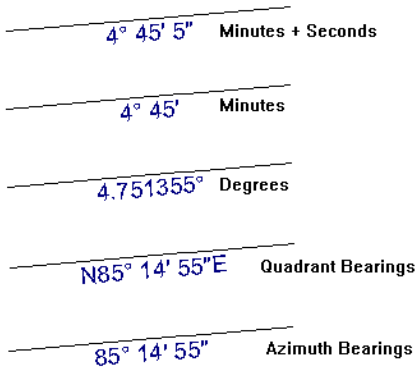

Line angles can be displayed using three basic methods:

- **Degrees/Minutes/Bearings** - Measured counterclockwise from a line drawn horizontally to the right of the angle's vertex. Useful for most drawing tasks. Select the level of accuracy that you require.
- **Quadrant Bearings** - Measured from a vertical line representing North/ South, Quadrant Bearings use directional bearings in their measurements. Useful for site drawings.
- **Azimuth Bearings** - Measured from a line drawn straight up from the angle's vertex (i.e., North on a site plan). Useful for site drawings, Azimuth Bearings use degrees, minutes, and seconds in their measurements.

 Line length and angle indicators use the Text Style of the layer that their object is on. See *Text Styles on page 538*.

### 4 Options

Select any combination of the available **Options**.

- Check **Show Arc Centers and Ends**  to show arc centers and ends on the current floor. Ends display as small lines where arcs connect to one another. Centers also acts as snap points. See *Arc Centers and Ends on page 223*.

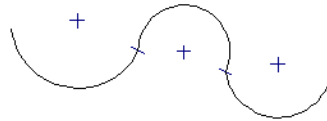

Show Arc Centers and Ends

## DISPLAYED LINE LENGTH DIALOG

The settings in the Displayed Line Length dialog control the appearance of CAD line length indicators, when set to display. See *Show Length and Angle on page 326*.

To access this dialog, click the **Define** button under the **Displayed Line Length Format** heading in the CAD Defaults dialog.

Most of the settings here are also found in the Number Formatting dialog accessible from the Materials List. They are also similar to settings found on the DIMENSION FORMAT panel of the Room Label Defaults dialog and the FORMAT panels of the Dimension Defaults dialog. See *Number Formatting Dialog on page 1321* and *Primary Format Panel on page 459*.

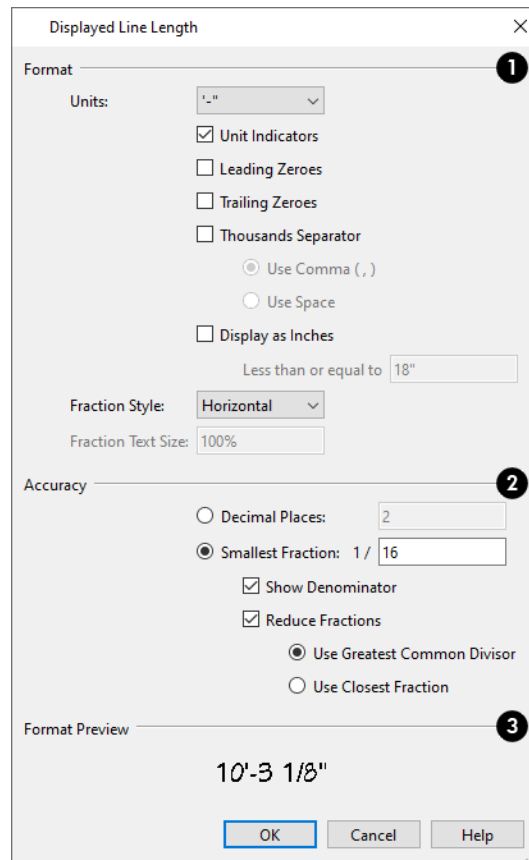

### 1 Format

Specify the numbering **Format** for CAD line length indicators.

- Select the **Units** of measurement to be used by line length indicators from the drop-down list.
- Check **Unit Indicators** to display the unit of measurement along with the dimension number.

- Check **Leading Zeros** to display the zero before a decimal less than 1 or to display 0' or 0" when the ft-in or '-"' unit formats are used.
- Check **Trailing Zeros** to display trailing zeros at the end of decimal values.
- Check **Thousands Separator** to use a thousands separator for values greater than 999.
- Select the **Use Comma** or **Use Dot** radio button to use a comma or a dot as the thousands separator. See *Region and Language Settings on page 78*.
- Select the **Use Space** radio button to use a space as the thousands separator.
- Check **Display as Inches** to display dimension line indicators of sufficiently short segments in inches rather than the Unit selected above. This option is only available when the specified Unit is a form of either feet or yards, or a format that includes feet. Not available in the Number Formatting dialog.
- The **Less than or equal to** value specifies how short a segment must be before its number uses inches rather than the specified Unit. Not available in the Number Formatting dialog.
- Select a **Fraction Style** from the drop-down list. This option affects the angle of the fraction's vinculum line.
- Specify the desired **Fraction Text Size** as a percentage of a selected dimension line's Number Height. Only available when either "Diagonal" or "Vertical" are selected as the Fraction Style. Not available in the Number Formatting dialog.

## 2 Accuracy

Specify the degree of accuracy used by line length indicators.

- Select the **Decimal Places** radio button for length indicators in decimal format. In the text field, specify the number of decimal places to use, from 0 to 20. If 0 is used, no decimal places are used.
- Select the **Smallest Fraction** radio button for length indicators using whole numbers and fractions. In the text field, specify the largest denominator to use, from 1 to 128. If 1 is entered, whole numbers are used. When Smallest Fraction is selected, the settings that follow are available:
  - Uncheck **Show Denominator** to turn off the display of fraction denominators used by line length indicators. Denominators are typically only turned off when eighths are desired.
  - Uncheck **Reduce Fractions** to always use the denominator specified above. When checked, the lowest possible denominator will be used and the two options below will be available.
  - Select the **Greatest Common Divisor** radio button to reduce fractions using the largest value that divides equally into the numerator and the denominator specified above. This option is best for fractional inches.
  - Select the **Closest Fraction** radio button to reduce fractions without referring to the denominator specified above. Not recommended when fractional inches are used.

A value of 0.33333 is represented by the fraction 5/16 when Greatest Common Divisor is used and the Smallest Fraction denominator is 16. When Closest Fraction is selected, this value is represented by 1/3.

## 3 Format Preview

A preview of the specified line length format displays here.

---





## The CAD Drawing Tools

The following CAD Tools are available in the CAD menu and the toolbars.

### POINT TOOLS







Select **CAD > Points** to access the Point Tools.

The **Place Point** , **Input Point** , **Point Marker** , and **Delete Temporary Points**  tools can be used to create or remove snap points for a variety of purposes. See [Point Tools on page 296](#).

### LINE TOOLS



Select **CAD > Line** to access the Line Tools.

The **Draw Line** , **Input Line** , **Line With Arrow** , **Sun Angle** , and the **North Pointer**  allow you to create various types of lines. See [Line Tools on page 300](#).

### ARC TOOLS



Select **CAD > Arcs** to access the Arc Tools.

The **Draw Arc** , **Input Arc** , and the **Arc With Arrow**  tools allow you to create arcs. See [Arc Tools on page 309](#).

### BOX TOOLS







Choose **CAD > Boxes** to access the Box Tools.

The **Rectangular Polyline** , **Regular Polygon** , **Box** , **Cross Box** , and **Insulation**  tools allow you to create a variety of polyline and box objects. See [Box Tools on page 319](#).

### CIRCLE TOOLS



Select **CAD > Circles** to access the Circle Tools.

The **Circle** , **Circle About Center** , **Oval** , and the **Ellipse**  tools are discussed in detail later in this chapter. See [Circle Tools on page 314](#).

### REVISION CLOUD



Select **CAD > Revision Cloud**, then click and drag to draw a rectangular shape with edges that display a series of arcs. See [Revision Clouds on page 321](#).

## SPLINE

 A Spline is a curve that passes smoothly through a set of points. Select **CAD> Spline** to draw connected line segments that form a spline. See *Splines on page 324*.

Once created, a spline can be selected and edited. See *Editing Spline-Based Objects on page 235* and *Polyline Specification Dialog on page 317*.

## DIMENSION TOOLS

 Select **CAD> Dimensions** or **CAD> Automatic Dimensions** to access the manually drawn and Automatic Dimension Tools. The **Dimension Tools** can be used with CAD and architectural objects and are discussed in their own chapter. See *Dimensions on page 448*.

## TEXT TOOLS

**T** Select **CAD> Text** to access the Text Tools. The Text Tools are discussed in their own chapter. See *Text, Callouts, and Markers on page 493*.

## CURRENT CAD LAYER

 Select **CAD> Current CAD Layer** to change the current default CAD layer. See *Current CAD Layer on page 326*.





## AUTO DETAIL

 Select **CAD> Auto Detail** while a cross section view is active to automatically generate CAD objects for commonly detailed structural components. See *Detailing Cross Section/Elevation Views on page 1094*.

---

# Point Tools

Select **CAD> Points**  to access the Point Tools.

Temporary points created using the **Place Point**  and **Input Point**  tools and permanent **Point Markers**  can be used with **Object Snaps**  to accurately position a variety of objects. See *Object Snaps on page 160*.

The size of temporary points is specified in the Preferences dialog. See *Snap Properties Panel on page 119*.

## PLACE POINT

 Select **CAD> Points> Place Point**, then click in the drawing area to place a temporary CAD point at that location. Temporary CAD points can be used for a variety of purposes: for example, as an anchor for snapping objects to a precise location. The Current CAD Point can be used for additional tasks. See *The Current Point on page 298*.

## INPUT POINT

 Temporary CAD points can be placed with precision by entering coordinates. See *3D Drafting on page 13*.



**To use the Input Point tool**

1. Select **CAD> Points> Input Point**  to open the New CAD Point dialog.
2. Select a **Location** option, and enter the desired location of the point.
3. Click **OK** to close the dialog and create the new point. The new point becomes the Current Point and is highlighted. See *The Current Point on page 298*.
4. Alternatively, click **Next** to create the new point but remain in the New CAD Point dialog and create additional points. As each is created, it becomes the Current Point.

**NEW CAD POINT DIALOG**

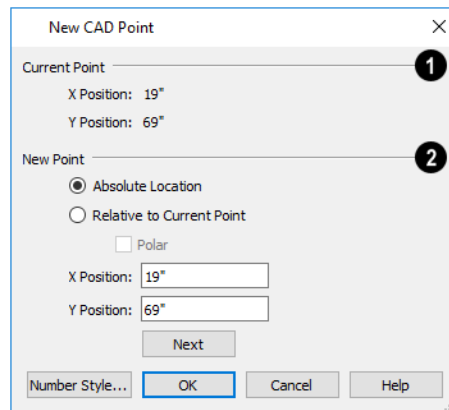

**1 Current Point**

The location of the **Current Point** displays here. If no CAD points are present, the origin (0, 0) displays. See *The Current Point on page 298*.

**2 New Point**

Specify the location of the **New Point**.

- **Absolute Location** - Define the point in **X Position** (horizontal) and **Y Position** (vertical) coordinates, relative to the origin at (0,0).
- **Relative to Current Point** - Define the new point in **X** and **Y** coordinates that are relative to the Current Point, as though that point was at (0,0). Only available when a Current Point exists.
- Check **Polar** to define the new point by its **Distance** and **Angle** from the Current Point rather than in **X** and **Y** coordinates. This is helpful when creating a plot plan. See *Plot Plans and Plan Footprints on page 1245*.

The position of the New Point is defined here. The options available depend on the method chosen to define it, above.

- **X Position** and **Y Position** coordinates relative to (0,0) are entered if the Absolute Location method is specified.
- **X Position** and **Y Position** coordinates relative to the Current Point are entered if the Relative to Current Point method is specified.
- **Distance** and **Angle** from the Current Point are entered if the Relative to Current Point: Polar method is specified.
- Click **Next** to create the new point without exiting the dialog so you can input data for the next point. The newly created point becomes the Current Point.



Click the Number Style button to change the units used in dialogs. See [Dialog Number/Angle Style Dialog on page 126](#).

## POINT MARKERS

 Use a permanent **Point Marker** as a snap point for dimension lines and other CAD objects. Select **CAD> Points> Point Marker** and click in the view to place a permanent point marker. Point markers display as a simple cross, with or without a text label. They can be opened for specification and modified to include a label or alter their attributes.

You can also place Point Markers using the **Marker**  tool, which lets you specify the marker label and type. See [Markers on page 529](#).

Point Markers are also created when the **Point to Point Dimension**  tool is used or when a dimension line is copied and pasted independent of the objects it locates. See [Point to Point Dimensions on page 470](#).

## DELETE TEMPORARY POINTS

 All temporary points in the current view can be deleted at once using **CAD> Points> Delete Temporary Points**. In plan view, Delete Temporary Points will delete all temporary points on all floors.

You can also press the **Delete** key when nothing is selected to delete the points one by one; however, **Delete Temporary Points**  can save time when there are many points.

## THE CURRENT POINT

In any view and on any floor, there may be multiple temporary CAD points. The Current Point is either the most recently created or most recently selected temporary CAD point. The Current Point has a variety of uses:

- As the starting point for objects as they are drawn by entering data. See [Entering Coordinates on page 166](#).
- As the point about which objects are rotated. See [Rotating Objects on page 259](#).
- To indicate the points at which roof planes can join. See [To find roof plane intersection points on page 812](#).

When multiple temporary points are on-screen, the Current CAD Point is highlighted so it can be easily identified.



### *To delete the Current Point*

1. Make sure no other objects are selected by clicking the **Select Objects**  button. You can also press the Esc key to deselect any selected objects.
2. Press the Delete key on the keyboard to delete the Current Point. The temporary point created prior to this one becomes the new Current Point.
3. If you continue pressing the Delete key, temporary points will be deleted in the reverse order that they were created.

## MOVE POINT DIALOG

A CAD Point can be repositioned relative to itself, another point, or a CAD object such as a line using the Move Point dialog. When a Point is moved, it becomes the Current Point.

For example, you can locate the point exactly one-quarter the distance along a given line, or exactly 6 inches from one end. This new location can then be used for the start point of a new line or other purpose.

To reposition a CAD Point, double-click on it using the **Select Objects**  tool. That point becomes the Current Point, and the Move Point dialog opens.

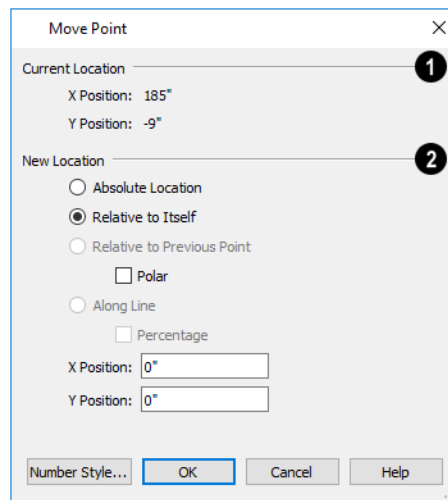

### 1 Current Location

The **Current Location** of the selected point displays at the top of the dialog for reference.

### 2 New Location

Specify the **New Location** of the point.

- **Absolute Location** - Define the new location in **X** (horizontal) and **Y** (vertical) **Position** coordinates, relative to the origin at (0,0).
- **Relative to Itself** - Define the new location in **X** and **Y Position** coordinates relative to the current location, as though that point were the origin.
- **Relative to Previous Point** - Define the new location relative to the point that was the Current Point prior to this one, as though that point was the origin. Only available if the selected point is located on a CAD object.
- Check **Polar** to define the new location's **Distance** and **Angle** from the previous point instead of using **X** and **Y** coordinates. Only available if Relative to Itself or to Previous Point is selected above.
- **Along Line** - Define the new location relative to the edge of a nearby CAD object. This option is enabled only when the point is located near a CAD object and refers to the end nearest to the point's original location.
- Check **Percentage (%)** to specify the Along Line value as a percentage of the total line or arc length rather than as a distance. 0% moves the point to the closest end of the nearest edge, 50% to the midpoint, and 100% to the other end. Negative numbers and percentages greater than 100 are allowed.
- Specify the new position of the point here. The options here depend on the method chosen to define the New Location.
- **X Position** and **Y Position** coordinates are entered if the Absolute Location method is specified or if either Relative method is used with Polar unchecked.
- **Distance** and **Angle** are entered if either Relative method is specified when Polar is checked.

- **From Edge** - When the Along Line method is used, specify the distance of the point's New Location to the end of the CAD object's edge that it was originally closest to. When **Percentage (%)** is checked, enter this value as a percentage instead.

If the point is near an arc, **Along Line** is measured along the curve.

If the point is near a box or polyline, **Along Line** is measured along the nearest side just as it does with an individual line or arc.

If the point is near an oval or circle, **Along Line** is measured along an (invisible) axis line that the item was originally drawn along.





Click the Number Style button to change the units used in dialogs. See [Dialog Number/Angle Style Dialog on page 126](#).

---

## Line Tools

 Select **CAD> Draw Lines** to access the Line Tools.



If **Object Snaps**  and **Connect CAD Segments**  are enabled, you can connect the ends of multiple lines and/or arcs to form a single entity called a polyline. See [Polylines on page 316](#).

### DRAW LINE

 There are three methods that you can use to draw lines with the **Draw Line** tool. The standard method is to select **CAD> Lines> Draw Line**, then click and drag from beginning to end.

An alternative method that allows you to draw multiple lines is also available. See [Alternate on page 207](#).

#### *To draw continuous lines*

1. Select **CAD> Lines> Draw Line** .
2. Press the Alt key on your keyboard (or use the right mouse button) and click and drag to draw a line. You can also toggle to alternative mode.
3. Move your cursor to a new location in the drawing area and click once. A new line is drawn beginning at end of the previous line.
  - Provided that **Connect CAD Segments**  is toggled on, a polyline will be formed. See [Connect CAD Segments on page 210](#).
4. To stop, press Esc on your keyboard or press two mouse buttons at the same time.

By default, this continuous drawing behavior will turn off when a closed shape is created. You can specify that this behavior remain on in the Preferences dialog. See [Behaviors Panel on page 118](#).

In addition, you can select a line style in the Library Browser and then click and drag in the drawing area to draw lines using that line style. See [Line Styles on page 199](#).





If you double-click the Draw Line tool, the Input Line dialog will open.

## INPUT LINE

↔ CAD lines can also be created using absolute values entered with the keyboard by selecting **CAD> Lines> Input Line**. This method is slower but more precise than using the mouse and is ideal when the desired length and angle of each line is known, such as with property lines.

Before any line is drawn using this method, a starting point must be defined. If a starting point has not been defined, Chief Architect assumes a starting point of 0,0.

### To use the Input Line tool

1. Select **CAD> Points> Place Point** , then click the screen to place a CAD point. This is the Current Point, and is the start point for the new line. See *The Current Point on page 298*.
2. Select **CAD> Lines> Input Line**  to open the New CAD Line dialog. This dialog can also be opened by double-clicking the **Line Tools**  parent button.
3. If necessary, specify the start point.
4. Specify the method used to define the location of the End Point, then define the End Point.
5. Click **OK** to close the dialog and draw the line, or click **Next** to draw the line but remain in the New CAD Line dialog and draw additional lines.

Note: If you accidentally click OK instead of Next and need to continue drawing a polyline using the New CAD Line dialog, select the Input Line tool again and continue.

## NEW CAD LINE DIALOG

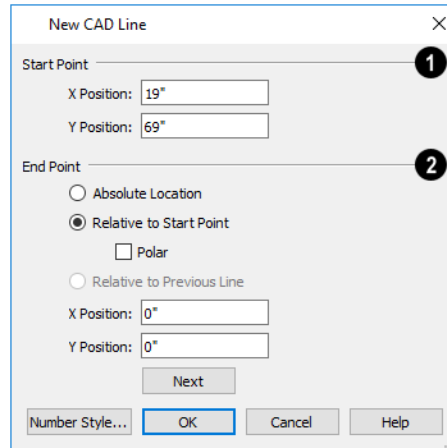

### 1 Start Point

The **X Position** (horizontal) and **Y Position** (vertical) coordinates of the start point for the new line display here. They can also be changed, if you wish.

### 2 End Point

The new line's **End Point** is defined here. Begin by specifying how you want to define the line **End Point Location**.

- **Absolute Location** - Define the end point of the new line in **X Position** (horizontal) and **Y Position** (vertical) coordinates, relative to (0,0).
- **Relative to Start Point** - Define the end point of the new line in **X** and **Y** coordinates that are relative to the line's Start Point, as though it were at (0,0).
- Check **Polar** to define the End Point of the new line by its **Distance** and **Angle** from the Start Point rather than in X and Y coordinates. This is helpful when creating a plot plan. See *Plot Plans and Plan Footprints on page 1245*.
- **Relative to Previous Line** - Define the End Point of the new line by its **Distance** and **Angle** relative to the end of the last line drawn, as though that line's angle were at 0° and its End Point, at (0,0).
- **X Position** (horizontal) and **Y Position** (vertical) coordinates relative to (0,0) are entered if the Absolute Location method is specified.
- **X Position** (horizontal) and **Y Position** (vertical) coordinates relative to the start point are entered if the Relative to Start Point method is specified.
- **Distance** and **Angle** from the start point are entered if the Relative to Start Point: Polar method is specified.
- **Distance** and **Angle** from the start point are entered if the Relative to Previous Line method is specified.
- Click **Next** to create the line without exiting the dialog so you can input data for the next line. The start point of the next line is the end point of this line.



Click the Number Style button to change the units used in dialogs. See *Dialog Number/Angle Style Dialog on page 126*.

### ***To enter an angle in bearings***

1. While not required, you may want to select **Quadrant** or **Azimuth Bearings** in the Dialog Number/Angle Style dialog.
2. For Quadrant Bearings, begin by typing *N* or *S* (for North or South).
3. Next, type the number of degrees followed by either a letter d or a space.
4. Type the number of minutes followed by either a ' or a space.
5. Type the number of seconds followed by either a " or a space.
6. Finally, for Quadrant Bearings, type either *E* or *W* (for East or West).

Following are some examples of Quadrant Bearings. It is not necessary to capitalize the letters. Spaces after each value are optional.

- N 20d 30' E
- S 45' W
- N 89d 48' 30" W
- N 90' E

### **ENTER COORDINATES**

Similar to **Input Line**, lines can also be specified by pressing the Tab key on the keyboard when a line is in the process of being drawn. This opens the Enter Coordinates dialog. See *Entering Coordinates on page 166*.

## LINE WITH ARROW

 Create a line or polyline with an arrow on one or both ends by selecting **CAD> Lines> Line With Arrow**, then clicking and dragging in the drawing area. The initial attributes of the line's arrow are set in the Arrow Defaults dialog. See *Arrow Defaults on page 495*.

As with other lines, lines with arrows can be edited after they are created and connected to form polylines provided that they share the same layer and style attributes. See *Editing Line-Based Objects on page 216* and *Line Specification Dialog on page 304*.

You can also create arcs with arrowheads. See *Arc with Arrow on page 311*.

 If either end of a Line with Arrow is snapped to an object, it maintains its connection if that object is moved. See *Text Arrows on page 519*.

## CONSTRUCTION LINE

 The **Construction Lines** tool allows you to create guide lines to help locate features of a design and ensure that objects are correctly aligned in plan view and cross section/elevation views. See *Construction Lines on page 65*.

## SUN ANGLE

 **Sun Angles** let you specify the date, time, latitude, and longitude that the program uses when calculating the angle of the Generic Sun as well as the direction and length of sun shadows. See *Sun Angles and Shadows on page 1143*.

## NORTH POINTER

 The **North Pointer** tool is used to define the direction of true north in a plan. The direction of north does not affect the orientation of the Snap and Reference grids, but it does determine the direction of bearing information as well as how shadows and conditioned area totals are calculated. See *North Pointer on page 1143*.

If a **North Pointer** is not used, north is assumed to be straight up on screen in plan view.

## DISCONNECT EDGES

 Select **CAD> Lines> Disconnect Edges**, then click on the edge of a polyline-based object to disconnect that edge from the rest of the polyline. See *Disconnect Edges on page 212*.

When **Connect CAD Segments**  is toggled off, CAD objects will not join to form a single polyline, either as they are drawn or when edited. See *Polylines on page 316*.

## LINE STYLE MANAGEMENT

 The Line Style Management dialog allows you to manage the line styles saved in the current plan or layout file. Select **CAD> Lines> Line Style Management** to access this dialog. See *Line Style Management on page 199*.

## SAME LINE TYPE EDIT HANDLES

A new CAD line can also be drawn using the Same Line Type edit handles on an existing CAD object. The start point of the new line is located at one end of the existing object and shares its line color, weight, style, and its layer. If the object has an arrow, its attributes are also inherited. See *Line Style Panel on page 305* and *Arrowheads on page 327*.

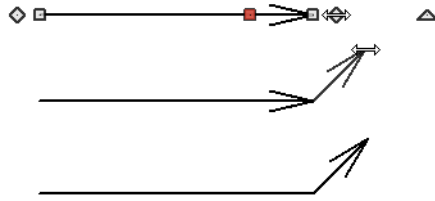

The Same Line Type edit handles are available for CAD lines, arcs, open polylines, and splines, but not for closed CAD shapes or CAD-based architectural objects. They can be turned off in the Preferences dialog if you wish. See [CAD Panel on page 114](#).

When **Connect CAD Segments**  is disabled, the new CAD line will snap to the existing object, forming an open polyline or spline. When **Connect CAD Segments** is enabled, on the other hand, the two will remain separate objects.

## Line Specification Dialog

Select a CAD Line, Line With Arrow, or Text Line With Arrow and click the **Open Object** edit button to open the Line Specification dialog.

The settings on the panels in this dialog are found in the specification and defaults dialogs for a variety of different objects in the program.

The Line Specification dialog has the following panels:

### LINE PANEL

The information on the LINE panel of the Line Specification dialog is similar to that found on the SELECTED LINE panels of various specification dialogs in the program.

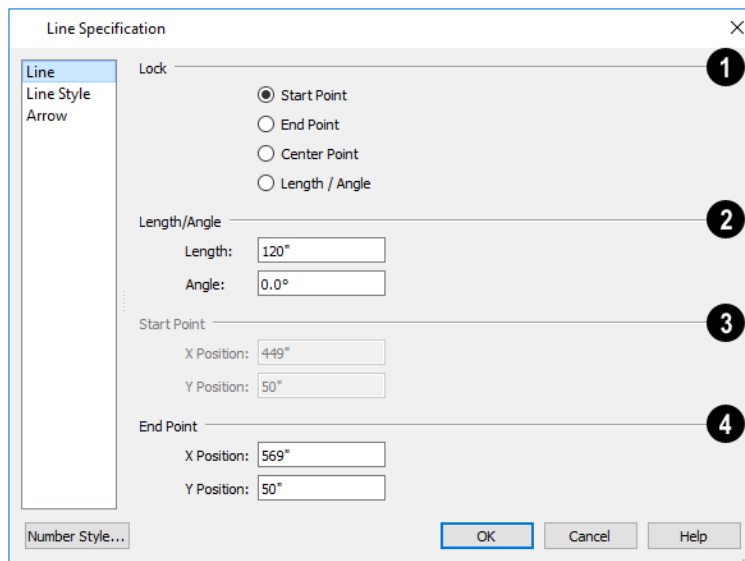

#### 1 Lock

These lock options control how changing properties on this dialog affect the line.



- Select **Start** to keep the start of the line fixed when changing the length, angle, and end.
- Select **End** to keep the end of the line fixed when changing the length, angle, and start.
- Select **Center** to keep the center of the line fixed. Changing the length of the line moves the start and end of the line equally. Changing the angle rotates the line around the center.
- Select **Length/Angle** to keep the length and angle of the line segment fixed. Moving the start or end moves the other end so the length and angle of the line do not change.

When editing a polyline, moving the Start of a line segment moves the end of the previous connected line, if there is one. Similarly, moving the End of a line segment moves the start of the next connected line, if there is one.

## 2 Length/Angle

Specify the **Length** and **Angle** of the selected line.

## 3 Start Point

Specify the X and Y coordinates of the line's **Start Point**. Not available when the Start or Center Point is locked.

## 4 End Point

Specify the X and Y coordinates of the line's **End Point**. Not available when the Center or End Point is locked.

The format used here can be changed by clicking the **Number Style** button. See *Dialog Number/Angle Style Dialog on page 126*.

## LINE STYLE PANEL

The LINE STYLE panel is found in the specification dialogs for many different objects. The settings here control the appearance of the lines and/or arcs that make up an object. Depending on the type of object selected, some settings may not be available. The available settings vary slightly depending on whether the object was drawn in a plan or a layout file. See *Line Styles on page 199*.

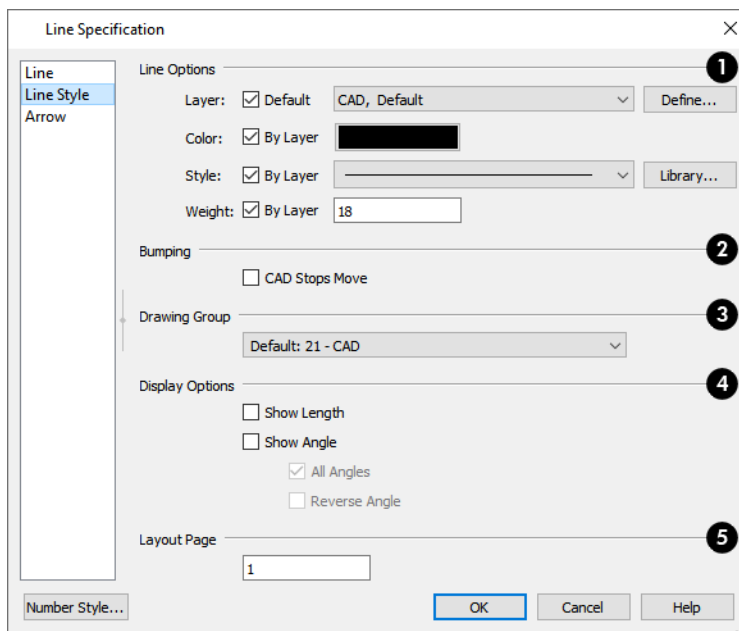

## 1 Line Options

- Check **Show Border** to display a border around the selected Picture file. Not available for other object types. See [Pictures on page 1191](#).
- Specify the **Layer** that the selected object should be located on. Check **Default** to use the default layer for the selected object's type or choose a layer from the drop-down list. If the selected object is an automatically generated dimension line, frieze molding, or shadow board that has been edited, Default will be unchecked.
- Click the **Define** button to open the Layer Display Options dialog. See [Layer Display Options Dialog on page 179](#).
- Specify the line **Color** used to represent the selected object. Check **By Layer** to use the color assigned to the object's layer or click the Color bar to select a different color. See [Color Chooser/Select Color Dialog on page 203](#).



Mouse over the Color bar to display a tool tip reporting the selected color's RGB values.

- Specify the line **Style** used to represent the selected object. Check **By Layer** to use the line style assigned to the object's layer or click the drop-down list or **Library** button to select a different style. The items in the drop-down list can be managed in the Line Style Management dialog. See [Line Style Management on page 199](#).
- Define the **Line Weight** or check **By Layer** to use the **Line Weight** assigned to the object's layer. See [Line Weights on page 1374](#).



Setting the line weight to zero makes the line weight print as thin as possible.

## 2 Bumping

Specify the desired **Bumping** behaviors for the selected object(s). These options are not available for Wall Material Regions and only function when **Bumping/Pushing** is enabled. See [Bumping/Pushing on page 243](#).

- Check **CAD Stops Move** to bump the selected object into other CAD or CAD-based objects as it is moved, and/or to push the other object(s).
- Check **Wall Stops Move** to stop the selected object when it bumps into a wall. Walls cannot be pushed by other objects. Not available in layout files.

## 3 Drawing Group

Specify which **Drawing Group** the selected object(s) is in. These options are not available in camera views. See [Drawing Groups on page 190](#).

## 4 Display Options

Select the desired **Display Options**. These options not available for CAD Box- or CAD Circle-based objects, or for Primitives, 3D Solids, Material Regions, North Pointers, or Sun Angles.

- Check **Show Length** to show the length of each line centered above the line.
- Check **Show Angle** to show the angle of each line centered below the line. If the object is an arc, its radius will also display.

The **Length** and **Angle** formats are specified in the CAD Defaults dialog. See [CAD Defaults Dialog on page 291](#).

- Uncheck **All Angles** to show only those angles that are neither horizontal nor vertical. This is automatically checked when **Show Angle** is checked.
- Check **Reverse Angle** to reverse the angle by 180°. This may be helpful when showing a line's bearing, since the direction a line is drawn from start point to end point defines its bearing.

An additional **Display Options** setting is available in the Picture File, Metafile, and PDF File Box Specification dialogs. See [Pictures, Images, and Walkthroughs on page 1184](#).

- Check **Show Border** to display the selected object's border polyline.

## 5 Layout Page

Specify the layout page that the selected object(s) is located on. Only available for objects drawn in layout files, but not in defaults dialogs for objects such as callouts and markers. See [Layout on page 1333](#).

## ARROW PANEL

The settings on ARROW panel allow you customize the style of arrowhead the selected object displays. See [Arrowheads on page 327](#).

# Drawing Arcs - Arc Creation Modes

There are five Arc Creation Modes that control how arcs and arc-based objects are drawn. Each mode allows you to specify a different aspect of the arc, such as its radius or tangent. Select **Edit> Arc Creation Modes** to select a mode.

The program remembers the last creation mode used between sessions. Once drawn, all arcs are edited similarly. See [Editing Arc-Based Objects on page 219](#).

Before deciding which Arc Tool or Arc Creation Mode is best for the project at hand, it is helpful to be familiar with the different components that make up an arc.

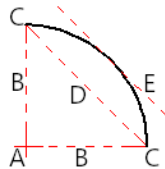

- A. **Center** - the point the arc is drawn about.
- B. **Radius** - the distance from the center to the arc.
- C. **Start / End** - where the arc begins and ends.
- D. **Chord** - the straight line between the start and end point.
- E. **Tangent** - a straight line that intersects an arc and is perpendicular to the radius of the arc at that point.

## FREE FORM ARC

**Free Form Arc** mode allows you to define an arc by clicking and dragging along the desired path. There are two methods for using this mode.

### ***To draw a Free Form arc***

1. Select **CAD> Arcs> Draw Arc** , then click at the arc's start point.
2. Move the pointer along the desired curve while dragging to curve the arc.
3. Release the mouse button at the end point to complete the arc.

### ***To draw continuous Free Form arcs***

1. Select **CAD> Arcs> Draw Arc** .
2. Press the Alt key on your keyboard and click and drag to draw an arc.
3. Move your cursor to a new location and click. A new arc is drawn that is connected to the end point of the previous arc.

By default, this continuous drawing behavior will turn off when a closed shape is created. You can specify that this behavior remain on in the Preferences dialog. See [Behaviors Panel on page 118](#).

## **CENTER/RADIUS/END ARC**



**Center/Radius/End Arc** mode allows you to define the center and radius of an arc, and then its length.

### ***To draw a Center/Radius/End arc***

1. Select **CAD> Arcs> Draw Arc** , then click at the center of the arc and drag to define the radius.
2. Release the mouse button, then move the mouse to the end of the arc and click again.

## **START/END/ON ARC**



**Start/End/On Arc** mode allows you to define the start and end points of an arc, then adjust the curvature.

### ***To draw a Start/End/On arc***

1. Select **CAD> Arcs> Draw Arc** , then click at the start point of the arc and drag to the end point.
2. Release the mouse button at the end point.
3. Move the mouse to adjust the curvature of the arc, then click to release the mouse and create the arc.

## **START/TANGENT/END ARC**



**Start/Tangent/End Arc** mode allows you to define the start and end points of an arc, its tangent and its curvature.

### ***To draw a Start/Tangent/End arc***

1. Select **CAD> Arcs> Draw Arc** , then click at the start of the arc and drag a line to define the arc's tangent at the start point.
2. Release the mouse button.
3. Move the mouse to adjust the length and curvature of the arc, then click to release the mouse and create the arc.

## ARC ABOUT CENTER

 **Arc About Center** mode allows you to draw an arc by defining the center and then the start and end points.

### *To draw an Arc About Center*

1. Select **CAD> Arcs> Draw Arc** , then click once to define the center point.
2. Click and drag from the start point of the arc to its end point.
3. Or, click and drag an arc. The Current Point is used as the center. See [The Current Point on page 298](#).

---

## Arc Tools

 Select **CAD> Arcs** to display the submenu of Arc Tools.



## DRAW ARC

 The method used to draw an arc using **Draw Arc** depends on which Arc Creation Mode is currently active. Once drawn, an arc can be edited. See [Editing Arc-Based Objects on page 219](#).

## INPUT ARC

 An arc can be drawn to exact specifications using the New CAD Arc dialog.

### *To use the Input Arc tool*

1. Select **CAD> Points> Place Point** , then click the screen to place a CAD point. This is the Current Point, and will be the start point for the new arc. See [The Current Point on page 298](#).
2. Select **CAD> Lines> Input Arc**  to open the New CAD Arc dialog.  
The New CAD Arc dialog can also be opened by double-clicking the **Arc Tools**  parent button.
3. If necessary, specify the Start Point.
4. Specify the method used to define the arc's Direction, then define its angle.
5. Define the arc's Radius. In order to create an arc, a value greater than 0 must be specified.
6. Define the arc's Extension, or length, using one of the three methods. In order to create an arc, one of these values must be greater than 0, and only one method should be used.
7. Click **OK** to close the dialog and draw the arc.

## NEW CAD ARC DIALOG

### 1 Start Point

The **X Position** (horizontal) and **Y Position** (vertical) coordinates of the **Start Point** for the new arc display here. They can also be changed, if you wish.

### 2 Direction

Specify how you want to define the arc's **Direction**, then specify its angle.

- The **Start Direction** defines the angle of the tangent from the arc's start point.
- The **Chord Direction** defines the angle of the arc's chord from the start point.

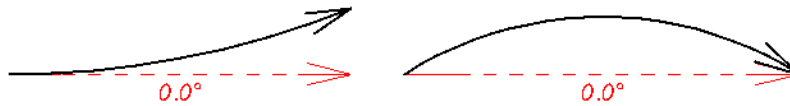

Start Direction at  $0^\circ$  vs Chord Direction at  $0^\circ$

### 3 Curve

- Define the arc's **Radius**.
- Select the direction that the arc curves: either to the **Right/Clockwise** or to the **Left/Counterclockwise**.

### 4 Length

Control the length of the arc by defining one of these:

- A. **Arc Angle** - the arc's central angle as measured between the radii of both start and end points.
- B. **Arc Length** - the length of the arc along its curve from one endpoint to the other.
- C. **Chord Length** - the linear distance between start and end point.

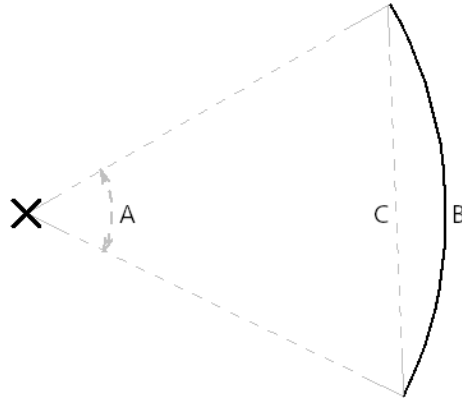

 Click the Number Style button to change the units used in dialogs. See [Dialog Number/Angle Style Dialog on page 126](#).

### ARC WITH ARROW

 You can create an arc with an arrow on one or both ends, using the **Arc With Arrow** tool. Draw an **Arc With Arrow** like a regular arc. When you release the mouse button, the arc has an arrowhead at the end. The default attributes of the arrow are determined by the settings in the Arrow Defaults dialog. See [Arrow Defaults on page 495](#).

As with regular arcs, arcs with arrows can be edited after they are created. See [Editing Arc-Based Objects on page 219](#) and [Arc Specification Dialog on page 311](#).

Continue to draw connected lines and arcs to form a polyline with an arrowhead at the end. The arrowheads display only at the free ends, not where the lines connect. See [Polylines on page 316](#).

Lines with arrowheads can also be created. See [Line With Arrow on page 303](#).

 A line can be converted to an arc or vice versa by selecting the line, pressing and holding down the Alt key, then using the edit handle at either end to bend the line.

---

## Arc Specification Dialog

 Select an arc and click the **Open Object** edit button to open the Arc Specification dialog.

The settings on the ARC panel are also found on the SELECTED ARC panels for many objects.

## ARC PANEL

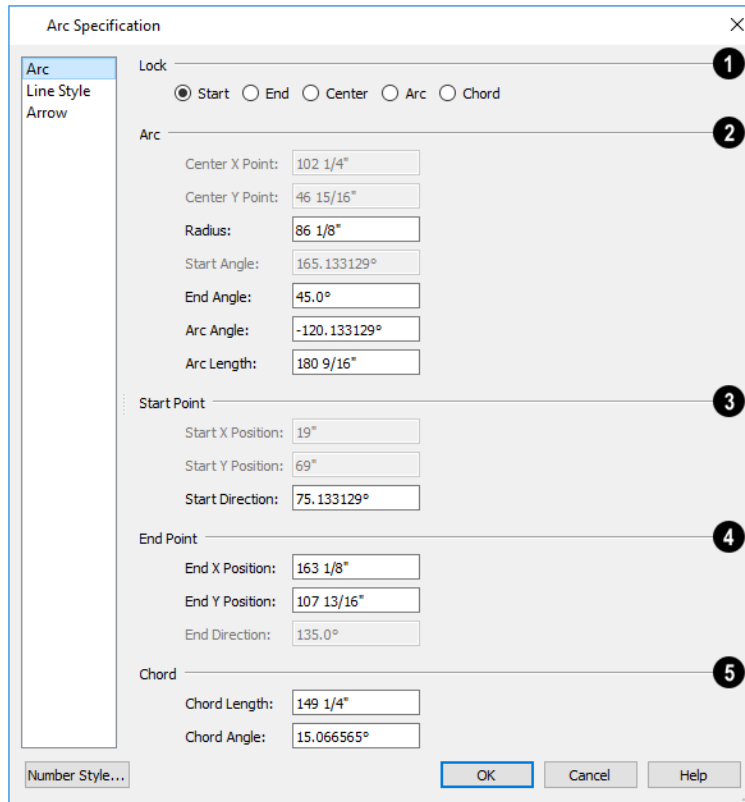

### 1 Lock

These options control how changing properties in this dialog affects the arc.

- **Start** - Select this option to keep the start fixed when changing the arc, chord, or end.
- **End** - Select this option to keep the end fixed when changing the arc, chord, or start.
- **Center** - Select this option to keep the center of the arc fixed when changing the arc.
- **Arc** - Select this option to keep the arc fixed when changing the arc location.
- **Chord** - Select this option to keep the arc chord fixed when changing the arc radius.

### 2 Arc

These parameters define the arc. Various controls are disabled depending on what lock option is used.

- **Center X Point** - Specify the X coordinate for the center of the arc.
- **Center Y Point** - Specify the Y coordinate for the center of the arc.
- **Radius** - The distance between the center of the arc and the arc surface.



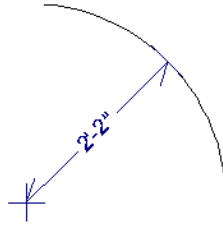

- **Start Angle** - Specify the angle that a line drawn from the arc center to the arc start makes with a horizontal line to the right.
- **End Angle** - Specify the angle that a line drawn from the arc center to the arc end makes with a horizontal line to the right.
- **Arc Angle** - The angle between the center of the arc and each end.

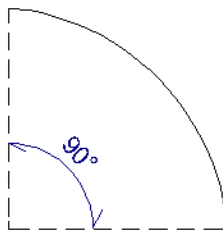

- **Arc Length** - The length of the arc along the curve.

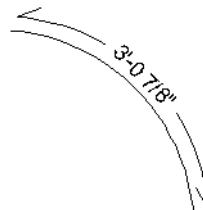

- Uncheck **Automatic Facet Angle** to specify the **Facet Angle**, which is the angle at which the surfaces of a curved 3D object are broken in 3D views. The default value is 7.5°; a smaller value produces a smoother curve while a larger value may generate more quickly in 3D views. These settings are only available on the SELECTED ARC panel for some CAD-based architectural objects such as Slabs. See *Architectural vs CAD Objects on page 158*.

### 3 Start Point

These values define the start point of the arc. The Position settings are disabled when the Start is locked.

- **Start X Position** - Specify the X coordinate for the beginning of the arc.
- **Start Y Position** - Specify the Y coordinate for the beginning of the arc.
- **Start Direction** - Specify the angle of a tangent line at the start of the arc.

### 4 End

These values define the end point of the arc. The Position settings are disabled when the End is locked.

- **End X Position** - Specify the X coordinate for the end of the arc.
- **End Y Position** - Specify the Y coordinate for the end of the arc.

- **End Direction** - Specify the angle of a tangent line at the end of the arc.

## 5 Chord

These values define the chord of the arc.

- **Chord Length** - The straight line distance between the two ends of the arc.

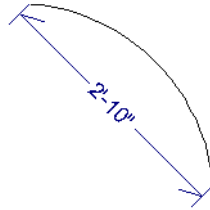

- **Chord Angle** - Specify the angle of the chord (the imaginary straight line going from the start of the arc to the end of the arc).

## LINE STYLE PANEL

For information about the LINE STYLE panel, see [Line Style Panel on page 305](#).

## ARROW PANEL

For information about the ARROW panel, see [Arrowheads on page 327](#).

---

# Circle Tools

 Select **CAD> Circles** to access the Circle Tools.

## CIRCLE



 To draw a circle, select **CAD> Circles> Circle**, then click and drag across the diameter, in any direction.

Once a circle is created, it can be edited. See [Editing Circles, Ovals and Ellipses on page 239](#) and [Circle/Oval/Ellipse Specification Dialog on page 315](#).

## DRAW CIRCLE ABOUT CENTER

 Select **CAD> Circles > Circle About Center** to create a circle by dragging the radius out from the center point.

### *To draw a Circle About Center*

1. Click the **Circle About Center**  tool.
2. Click the screen to define the center.
3. Drag the radial distance and release the mouse button. If you are using **Object Snaps** , both the center point and the radius snap to any appropriate nearby CAD object, intersection or point.

## OVAL

 An **Oval** is a four-arc approximation of an ellipse. To draw an oval, select **CAD> Circles> Oval**, then click and drag at an angle to define the oval's maximum height and width.

Once an oval is created, it can be edited. See *Editing Circles, Ovals and Ellipses on page 239* and *Circle/Oval/Ellipse Specification Dialog on page 315*.

## ELLIPSE

 An **Ellipse** is a set of points with a constant combined distance from two points called foci. An ellipse looks like a stretched circle, or a circular surface viewed at an angle. To draw an ellipse, select **CAD> Circles> Ellipse** and drag at an angle to define its maximum height and width.

Once an ellipse is created, it can be edited. See *Editing Circles, Ovals and Ellipses on page 239* and *Circle/Oval/Ellipse Specification Dialog on page 315*.

---

# Circle/Oval/Ellipse Specification Dialog

Select a circle, oval or ellipse and click the **Open Object**  edit button to open the CAD Circle, Oval or Ellipse Specification dialog.

The CAD Circle, Oval, and Ellipse Specification dialogs are almost exactly the same. The Oval and Ellipse Specification dialogs have an additional setting for **Angle** on the **GENERAL** panel.

## GENERAL PANEL

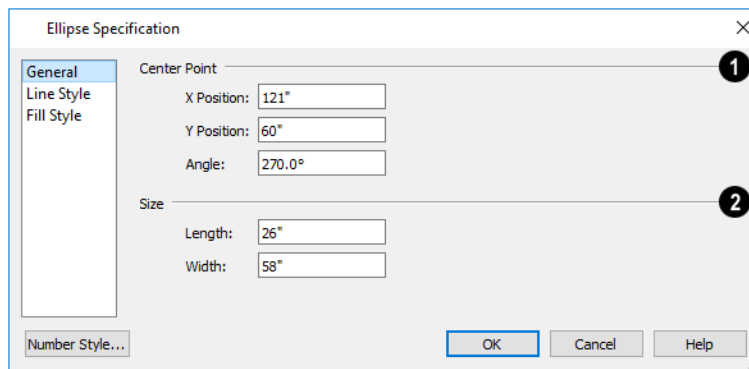

### 1 Center Point

Specify the position of the circle, oval or ellipse's **Center Point**.

- Specify the **X Position** and **Y Position** of the center of the circle, oval or ellipse.
- Specify an oval or ellipse's **Angle**. Not available for circles.

### 2 Size

- Specify the **Length** and **Width** of an oval or ellipse, or the **Diameter** and **Radius** of a circle.
- Specify the **Circumference** of a selected circle. Not available for ovals or ellipses.

## LINE STYLE PANEL



For information about the LINE STYLE panel, see [Line Style Panel on page 305](#).

## FILL STYLE PANEL

For information about settings on this panel, see [Fill Style Panel and Dialogs on page 193](#).

# Polylines

 A polyline consists of two or more line and/or arc segments that are attached at their endpoints. Select **CAD> Boxes> Rectangular Polyline**, then click and drag from corner to corner to create a rectangular-shaped, closed polyline. A closed polyline measuring 2'x 2' (600 mm x 600 mm) can also be created by clicking once while the **Rectangular Polyline** tool is active.

When **Object Snaps**  and **Connect CAD Segments**  are enabled, you can also create a polyline by drawing lines and/or arcs end-to-end, allowing the end of each new object to snap to the end of the previous one. See [Defaults, Preferences, and Edit Behaviors on page 206](#).

Line- and arc-based objects will only snap together to form a polyline if they are on the same layer and share identical attributes such as color, line style, and arrow specifications.

If one end of the polyline is connected to the other, it becomes a closed polyline. Closed polylines can be adjusted in a variety of ways that open polylines cannot. For example, closed polylines can be assigned a fill pattern and/or turned into special 3D objects such as slabs or countertops that display in 3D views.

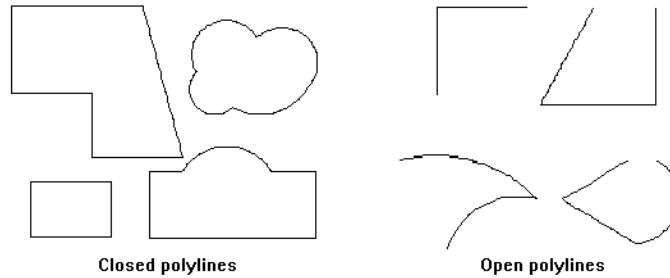

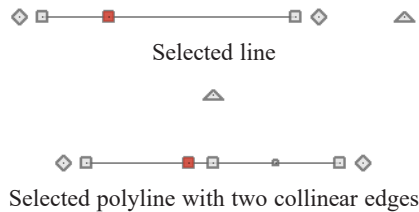

Lines and polylines can be distinguished by the edit handles that display when you select each. A line displays an edit handle at each end and one in the middle. If more than three edit handles display, the object is a polyline.

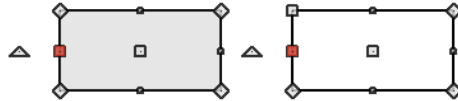

Lines that appear connected to a polyline may prove to be unconnected when selected.

For example, the two polylines in the following image appear identical until their left edges are selected. The entire polyline on the left is highlighted, showing it is a closed polyline. The polyline on the right, however, reveals that its left edge is not fully attached. In contrast, the left edge of the polyline on the left is part of the larger polyline unit.



The **Close Polyline**  edit tool can be used to connect the edges of an open polyline. This tool adds a segment between the two open ends, closing the gap between them. See [Close Polyline on page 228](#).

Polylines can be copied, moved, reshaped, or resized as a single unit. Additionally, the individual segments can be edited. See [Disconnect Edges on page 212](#).

Once created, polylines can be edited in a variety of ways. See [Editing Open Polyline-Based Objects on page 224](#) and [Editing Closed Polyline-Based Objects on page 228](#).

## POLYLINE HOLES

Closed CAD Polylines and a variety of closed polyline-based architectural objects can contain one or more holes. See [Polyline Holes on page 232](#).

---

# Polyline Specification Dialog

 Select an open polyline, closed polyline, spline, Sprinkler Line polyline, or Electrical connection and click the **Open Object** edit button to open the Polyline Specification dialog.

The panels that are available in the Polyline Specification dialog will vary, depending on the attributes of the selected polyline as well as those of its selected edge.

## POLYLINE PANEL

The POLYLINE panel is found in the specification dialogs for a variety of objects throughout the program. It states:

- The total number of **Polylines** or **Holes Selected**;
- The **Length** of an open polyline;
- The **Perimeter** of a closed polyline;
- The **Area** of a closed polyline;
- The **Volume** of a closed polyline;
- The **Number of Lines** that form an open polyline or the perimeter of a closed polyline or polyline hole;
- The **Number of Holes** located inside a closed polyline;
- The **Hole Perimeter** is the total length of the perimeter(s) of any holes inside a closed polyline;
- The **Hole Area** is the total area of the holes located inside a closed polyline.

If the polyline is not closed, the Area and Volume are described as “Not closed”. The Volume of a 2D polyline will always be 0, even if it is closed.

If the selected object is a closed polyline and has any Holes in it, they will be subtracted from the **Area** value and, if applicable, from its **Volume**. See [Polyline Holes on page 232](#).

If multiple objects of the same type are selected, the combined totals of these values are stated.

## SPLINE PANEL

The SPLINE panel has a single option and is only available when the selected object is a spline. See [Splines on page 324](#).

New Segment Angle:

- **New Segment Angle** - Specify the angle between line segments that are used to draw the spline. Specifying a smaller angle makes the spline smoother. Specify a larger angle to draw the spline faster.

## SELECTED LINE PANEL

The SELECTED LINE panel is available when the selected edge of the polyline is a line as opposed to an arc and is not available if the selected object is a spline. See [Editing Line-Based Objects on page 216](#).

Moving the Start of a line segment moves the end of the previous connected line, if there is one. Similarly, moving the End of a line segment moves the start of the next connected line, if there is one.

This panel is similar to the LINE panel of the Line Specification dialog. See [Line Panel on page 304](#).

## SELECTED ARC PANEL

The SELECTED ARC panel is available when the selected segment of the polyline is an arc as opposed to a line. It is not available if the selected object is a spline.

This panel is similar to the ARC panel of the Arc Specification dialog. See [Arc Panel on page 312](#).

## LINE STYLE PANEL

This panel is similar to the LINE STYLE panel in the Line Specification dialog. See [Line Style Panel on page 305](#).

## FILL STYLE PANEL

The FILL STYLE panel is found in the specification dialogs for a variety of objects in the program. Only available for closed polylines. See [Fill Style Panel and Dialogs on page 193](#).

## ARROW PANEL

The ARROW panel is available for most open polylines and splines and is similar to the ARROW panel of the Line Specification dialog. See [Arrowheads on page 327](#).

The ARROW panel is not available for closed polylines, Sprinkler Lines, or Electrical Connections.

## LABEL PANEL

Labels for CAD polylines display when the “Polylines, Labels” layer is turned on and use the Text Style assigned to that layer. See [Text Styles on page 538](#).

For more information about the settings on this panel, see [Label Panel on page 700](#).

## COMPONENTS PANEL

The COMPONENTS panel is available for a selected Sprinkler Line or Sprinkler Spline. See [Sprinkler Tools on page 1301](#).

The information on this panel can be used in the materials list. See [Components Panel on page 1330](#).

## COMPONENTS PANEL

The information on the COMPONENTS panel can be used in the materials list. For more information, see [Components Panel on page 1330](#).

## OBJECT INFORMATION PANEL

The information entered on the OBJECT INFORMATION panel can be used in schedules. Not available for Electrical Connections, Sprinkler Lines, or CAD polylines drawn in layout files. For more information, see [Object Information Panel on page 1331](#).

## SCHEDULE PANEL

The settings on the SCHEDULE panel determine which schedule categories the selected object is included in. Not available for Electrical Connections, Sprinkler Lines, or CAD polylines drawn in layout files. See [Schedule Panel on page 704](#).

---

# Box Tools

Select **CAD> Boxes** to access the Box Tools.

## RECTANGULAR POLYLINE

A **Rectangular Polyline** can be created in either of two ways:

- Click in the drawing area to place a 24" x 24" square polyline at that location.
- Click and drag from corner to corner to draw a rectangle of any size.

CAD polylines can also be created by connecting CAD lines and/or arcs. See [Polylines on page 316](#).

Once created, a rectangular polyline can be edited into any shape or converted to a 3D object. See [Editing Closed Polyline-Based Objects on page 228](#).

## REGULAR POLYGON

 You can draw a regular polygon based on the length of a side, or the length of the radius to a vertex or a side. Select your options in the New Regular Polygon dialog and click OK, then click in the drawing area to place the polygon.

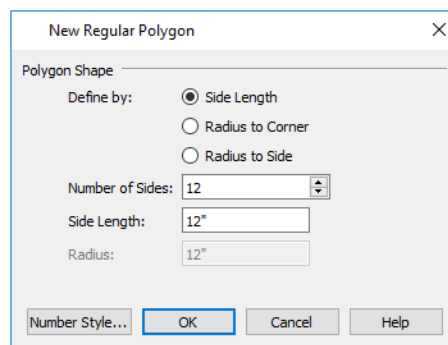

The settings in this dialog are similar to those in the Polygon Shaped Rooms dialog. See [Polygon Shaped Rooms and Decks on page 356](#).

## BOX

- Select **CAD> Boxes> Box** to draw a 2D rectangular polygon shape. CAD Boxes are drawn from corner to corner, forming a rectangle.

The sides of a Box can be resized, but unlike a polyline, a Box always has four 90° corners. See [Editing Box-Based Objects on page 232](#) and [Box Specification Dialog on page 320](#).

## CROSS BOX

- Use the **Cross Box** tool to create a 2D box with an X-shaped cross in the interior to represent framing in a cross section detail.

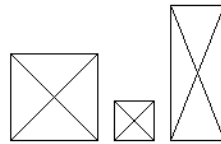

In cross section/elevation views, Cross Boxes are used to represent joists and rafters members that are perpendicular to and cut by the camera's clip plane. See [Cross Section/Elevation Views on page 1089](#).

## BLOCKING BOX

- Use the **Blocking Box** tool to create a 2D box with a diagonal line in the interior to represent blocking or bridging in a cross section detail.



## INSULATION

- Use the **Insulation** tool to draw insulation in cross section details. Insulation Boxes are like 2D boxes and Cross Boxes; however, unlike these other types of boxes, Insulation Boxes do not have perimeter lines: only the curves of the insulation pattern.

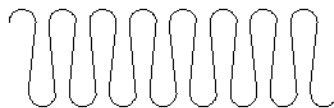

---

## Box Specification Dialog

- Select a CAD box, a framing box, a wall bridging box, a Cross box, a Blocking box, or an Insulation box and click the **Open Object** edit button to open the Box Specification dialog. See [Box Tools on page 319](#).



## GENERAL PANEL

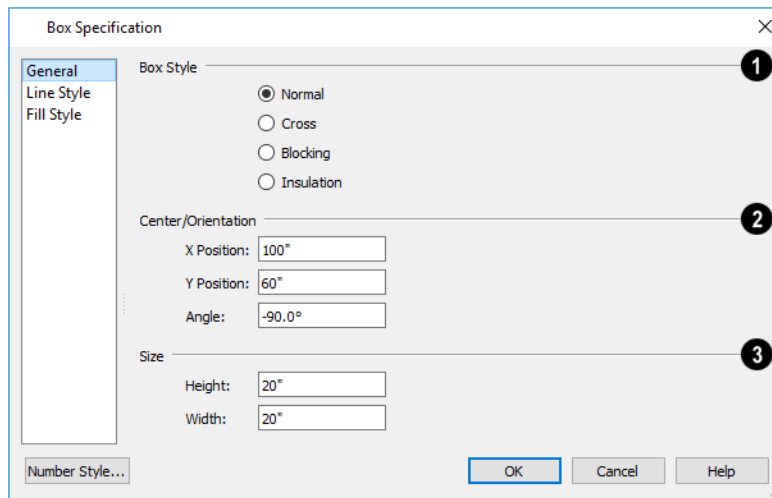

### 1 Box Style

Specify a **Box Style**. Select **Normal** to specify a normal box, **Cross** to specify a cross box, or **Insulation** to specify an insulation box. If multiple CAD boxes are selected, “No Change” may display.

### 2 Position

Define the **Position** of the box.

- Specify the **X Position** and **Y Position** of the center of the box.
- Specify the **Angle** of the box.

### 3 Size

Define the **Size** of the box by specifying its **Height** and **Width**.

## LINE STYLE PANEL

For information about the LINE STYLE panel, see [Line Panel on page 304](#).

## FILL STYLE PANEL



For information about the FILL STYLE panel, see [Fill Style Panel and Dialogs on page 193](#).

---

# Revision Clouds

 The **Revision Cloud** tool allows you to draw a closed polyline with a series of arcs or bulges displaying along each edge. Select **CAD> Revision Cloud**, then click and drag to draw a rectangular shape with edges that display a series of arcs.

There are several additional ways to create a Revision Cloud:

- Click and drag using the **Alternate**  edit mode to draw the first edge, then click to define the end points of subsequent edges. Click on the start point of the first edge to finish drawing the cloud. The **Revision Cloud**  tool is still active until you select a different tool. See [Alternate on page 207](#).
- Create Revision Clouds around one or more selected objects in plan view by clicking the **Revision Cloud(s) Around Objects**  edit button. A separate revision cloud will be drawn around each selected object. This edit tool is also available for CAD objects, text, and dimensions in cross section/elevation views, but not for architectural objects.
- Convert a closed CAD polyline into a Revision Cloud. See [Convert Polyline on page 262](#).

Revision Clouds are drawn based on the settings in the Revision Cloud Defaults dialog and are initially placed on the layer specified there. Unlike other CAD objects, they support multiple Saved Defaults and can be included in Default Sets. See [Multiple Saved Defaults on page 79](#).

Once created, Revision Clouds can be selected and edited much like other closed-polyline based objects. See [Editing Closed Polyline-Based Objects on page 228](#).

Unlike other closed polylines, however, the edges of a Revision Cloud can only be seen when it is selected. When it is not selected, only the arcs along its perimeter are visible.

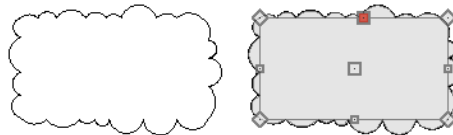

Unselected vs selected Revision Cloud

The arcs along a Revision Cloud are not its actual edges and cannot be individually selected, although you can control their size and frequency. See [Revision Cloud Specification Dialog on page 322](#).

If you wish to individually edit the arcs, convert it to a plain polyline. See [Convert to Plain Polyline on page 265](#).

---

## Revision Cloud Specification Dialog

 Select one or more Revision Clouds and click the **Open Object** edit button to open the Revision Cloud Specification dialog.

The settings in the Revision Cloud Defaults dialog are similar to those in the Revision Cloud Specification dialog, but determine the initial settings of revision clouds as they are drawn. See [Revision Cloud Defaults on page 291](#).

The Revision Cloud Specification dialog has the following panels:

## CLOUD PANEL

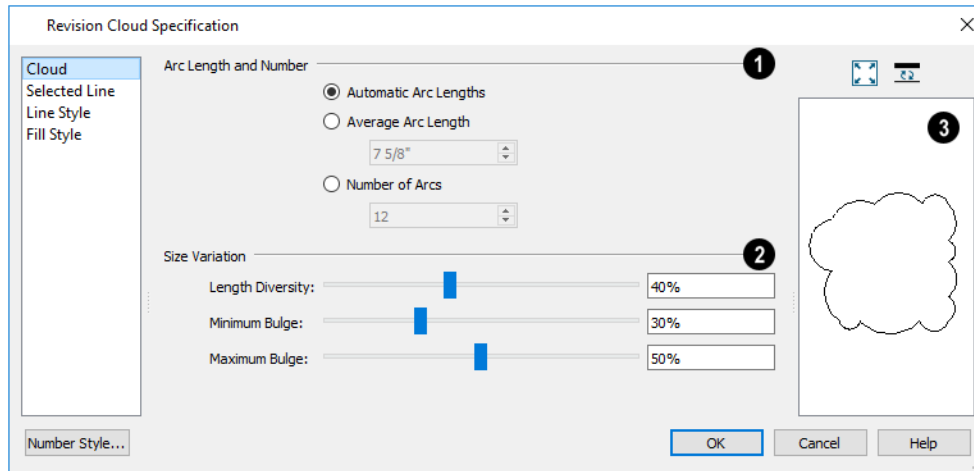

### 1 Arc Length and Number

Specify how the arcs on the selected revision cloud(s) are sized.

- Select **Automatic Arc Lengths** to have the program automatically size the selected cloud's arcs.
- Select **Average Arc Length** to specify the selected cloud's average arc length, which is measured along its chord.
- Select **Number of Arcs**, then specify the number of arcs on the selected cloud.

### 2 Size Variation

Use the slider bars or text fields to specify the **Size Variation** of the selected cloud's arcs.

- Specify the **Length Diversity**, which is the maximum amount that a given arc's length can deviate from the Average Arc Length, specified above.
- Specify the **Minimum Bulge**, which is the smallest amount that a given arc can extend out from its center. 0% allows arcs with a radius of 0, essentially flat lines; 50% allows 180° arcs, or half-circles; 100% only allows arcs of about 300°.
- Specify the **Maximum Bulge**, which is the largest amount that a given arc can extend out from its center. 100% allows arcs of about 300°; 50% allows 180° arcs; 0% only allows arcs with a radius of 0.

### 3 Preview

A preview of the selected revision cloud displays on the right side of this panel. See *Dialog Preview Panes on page 22*.

## SELECTED LINE/ARC PANEL

The **SELECTED LINE** panel is available when the selected cloud edge is a line as opposed to an arc. See *Line Panel on page 304*.

The **SELECTED ARC** panel is available when the selected segment of the cloud edge is an arc as opposed to a line. See *Arc Panel on page 312*.

See, too, *Selected Edge on page 212* and *Change Line/Arc on page 256*.

## LINE STYLE PANEL

For information about the settings on this panel, see [Line Style Panel on page 305](#).

## FILL STYLE PANEL

The FILL STYLE panel is found in various dialogs throughout the program. See [Fill Style Panel and Dialogs on page 193](#).



---

# Splines

 A Spline is a curve that passes smoothly through a set of points. Splines are typically used in situations where there is an irregular curve. A contour line is a typical example. Splines are useful wherever a free-flowing curve is needed.

Once created, splines can be selected and edited. See [Editing Spline-Based Objects on page 235](#) and [Polyline Specification Dialog on page 317](#).

### To use the Spline tool

1. Select **CAD> Spline** .
2. Make sure that **Connect CAD Segments**  are enabled so multiple spline segments can snap together. See [Connect CAD Segments on page 159](#).
3. Click and drag to draw the first spline segment just as you would a line. A single spline segment looks identical to a line, in fact. You may need to turn off **Angle Snaps**  to draw freely.

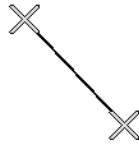

Spline line drawn between two points

4. Draw the second segment from the end of the first at a different angle. **Object Snaps**  should be on to assure that new segments attach correctly to the ends of previous segments.

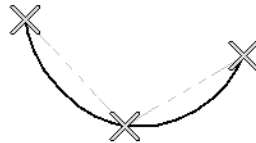

Spline polyline drawn between three points

5. As soon as two straight spline segments connect end-to-end, the straight segments become a curve that passes through the endpoints defined by the original segments. Each point is called a vertex.
6. Draw a few more segments, connecting each to the free end of a previously drawn segment.

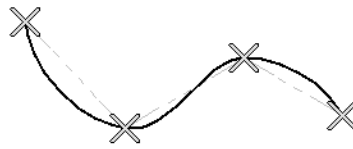

Spline polyline drawn between four points

7. Notice as additional segments are drawn that the spline changes the curvature of the previous segment to create a continuous curve between the last three points.



Spline polyline drawn between five points

8. Form a closed spline by drawing a segment between its two free ends.

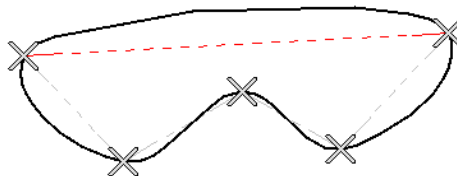

Draw additional segment to close polyline

9. The result is an irregular curve that flows smoothly through each vertex.



Spline-based objects will only snap together to form a single spline if they are on the same layer and share identical attributes such as color, line style, and arrow specifications.

Note: Spline-based objects with the same properties will only snap together when Connect CAD Segments is enabled. See [Connect CAD Segments on page 210](#).

You can also convert an open or closed polyline into a spline using the **Convert to Spline**  edit tool. See [Convert to Spline on page 258](#).

---

## Displaying CAD Objects

As with architectural objects, the display of CAD objects is controlled in the Layer Display Options dialog. See [Layer Display Options Dialog on page 179](#).

CAD objects can be drawn in plan views, CAD Details, layout, and cross section/elevation views. They are 2D objects only, though, so they cannot be seen in any view other than the one they are drawn in and are never visible in camera views or overviews. See *Architectural vs CAD Objects on page 158*.

Open and closed CAD Polylines can be listed in schedules. See *Schedule Categories on page 684*.

## CURRENT CAD LAYER

 When drawn, most CAD objects are automatically placed on the **Current CAD Layer**. In floor plan and cross section/elevation views, the name of this layer displays on the right side of the Status Bar at the bottom of the screen. See *The Status Bar on page 24*.

Initially, the “CAD, Default” layer is set as the Current CAD Layer, but this can be changed at any time in any of several ways:

- In the CAD Defaults dialog. See *CAD Defaults Dialog on page 291*.
- By selecting **CAD> Current CAD Layer**  from the menu. See *Select Layer Dialog on page 186*.
- Activate a different Default Set. See *Default Sets on page 83*.

Revision Clouds are placed on the layer specified in the Revision Cloud Defaults dialog - not on the Current CAD Layer. See *Revision Clouds on page 321*.

 Changing the Current CAD Layer affects subsequently-drawn objects, but existing CAD objects are unaffected by the change. As a result, you can efficiently produce CAD drawings on multiple layers.

## SAVED PLAN VIEWS AND DEFAULT SETS

The Current CAD Layer is among the items associated with Saved Plan Views and Default Sets, both of which can be customized and activated for specific drawing tasks. See *Plan Views on page 146* and *Default Sets on page 83*.

## DRAWING GROUPS

Each object in a plan or layout file is included in a Drawing Group, which influences whether it displays in front of or behind other objects. By default, CAD objects are placed in Drawing Group 21. Their drawing order relative to one another is based on the order in which they were placed: an object will display in front of any objects that were created before it was.

Once created, however, the drawing order of CAD objects can be customized. See *Drawing Groups on page 190*.

## SHOW LENGTH AND ANGLE

You can specify that line segment length and angle display along a CAD line, CAD arc, or along each segment of a CAD polyline. If the segment is an arc, its radius also displays. See *Line Style Panel on page 305*.

The format of the length and angle can be specified in the CAD Defaults dialog. See *CAD Defaults Dialog on page 291*.

Line length and angle indicators use the Text Style assigned to the layer that their CAD object is on. See *Text Styles on page 538*.

## ENDCAPS

Dashed lines often display endcaps, which are dashes of a particular length. You can specify the Printed Length of endcaps in the Preferences dialog. See *CAD Panel on page 114*.

## LINE STYLES

A selection of line styles is available in the Library Browser which you can apply to both CAD and architectural objects. See *Line Styles on page 199*.

If you do not see a line style that meets your needs, you can create your own custom line styles. See *Line Style Management on page 199*.

## FILL STYLES

A selection of fill styles can be applied to closed CAD and CAD-based architectural objects. See *Fill Styles on page 192*.

---

# Arrowheads

A variety of objects in Chief Architect can display arrows and be assigned various styles of arrowheads, including open CAD shapes, dimension lines, Callouts, Stairs, and Ramps. See *Callout Specification Dialog on page 526*, *Staircase Specification Dialog on page 771*, and *Ramp Specification Dialog on page 784*.

Some objects, notably Joist Direction Lines, do not have the Attach or Auto Position settings. Other objects, including closed polylines, Sprinkler Lines and Electrical connections cannot have arrows at all.

## ARROW PANEL

The defaults for arrowheads assigned to CAD objects are set in the Arrow Defaults dialog. See *CAD Defaults and Preferences on page 291*.

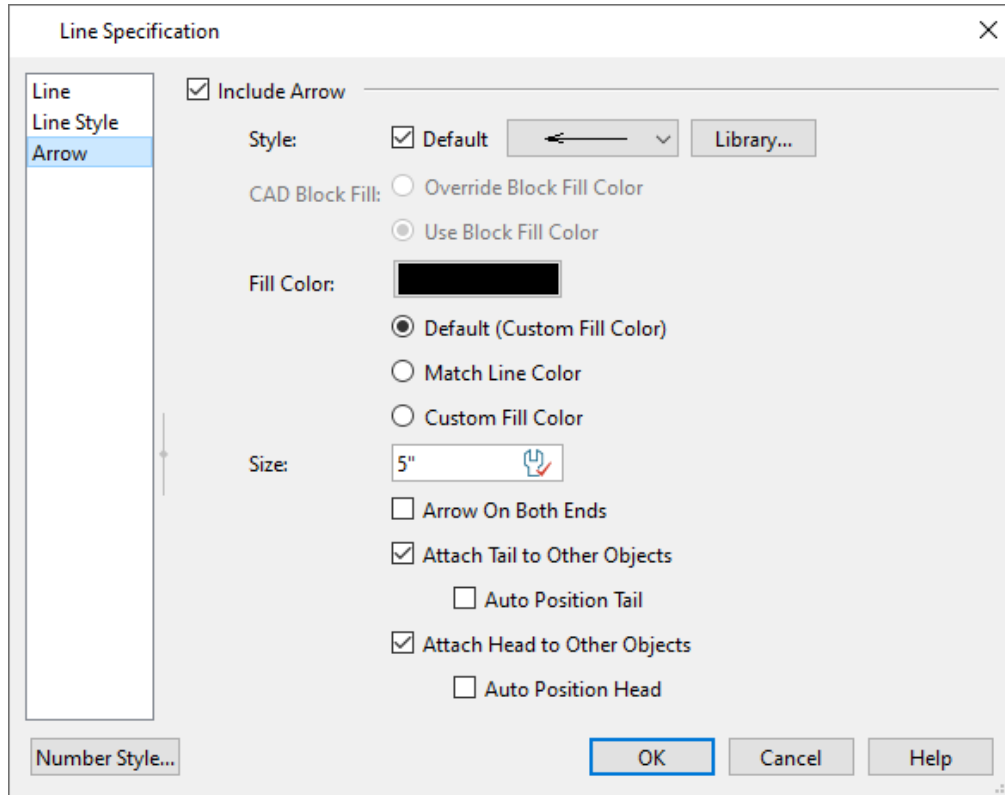

- Check **Include Arrow** to apply an arrow to the tail end of the selected object and enable the settings that follow. If a selected Callout does not have a Cross Section Line specified, one will be created.
- Select an arrowhead **Style** from the drop-down list or by clicking the **Library** button.
  - Check **Default** to use the default arrowhead.
  - Arrowheads with a white center have a transparent fill.
  - Arrowhead styles that draw perpendicular to the line are positioned at a positive 90° angle relative to the line's direction.

 You can create custom arrow styles using CAD blocks. See [Custom Arrowheads on page 329](#), below.

- The arrowhead's **Fill Color** displays in the Color bar. Click the bar to specify a custom color. See [Color Chooser/Select Color Dialog on page 203](#).
  - Select **Default Fill Color** to use the fill color specified in the Arrow Defaults or Callout Defaults dialog.
  - Select **Match Line Color** to use the color specified on the LINE STYLE panel. See [Arrowheads on page 327](#).
  - **Custom Color** is selected automatically if you click the Color bar above.
- Specify the arrowhead's **Size**, measured from its front to its back. The Default Size value also affects the size of the start circle for **Running Dimensions** . See [Running Dimensions on page 471](#).

The options that follow are not available for Callout Section Arrows:

- Check **Arrow on Both Ends** to place an arrowhead on both ends of the selected object.
- When **Attach Tail to Other Objects** is checked, the tail end of the arrow will attach to another object when snapped to it, and will maintain its attachment if the object is moved. When this is checked and the arrow is selected, its tail end edit handle will display the Selected Edge Handle Fill color.



- Check **Auto Position Tail** to have the tail end update its position on the object it is attached to if either object is moved. See [Auto Position Arrows on page 520](#).
- When **Attach Head to Other Objects** is checked, the head of the arrow will attach to another object when snapped to it, and will maintain its attachment if the object is moved. When this is checked and the arrow is selected, its arrow end edit handle will display the Selected Edge Handle Fill color.
- Check **Auto Position Head** to have the arrow end update its position on the object it is snapped to if either object is moved.

## CUSTOM ARROWHEADS



If you do not see an arrowhead style that meets your needs in the **Style** drop-down list, you can create one using the CAD tools: draw the desired shape, convert it into a CAD block, and add it the User Catalog. See [CAD Blocks on page 329](#).

When creating a custom arrowhead shape, bear in mind:

- By default, the left side of the shape will become the back of the arrowhead, where it meets its owner object.
- For the purposes of designing an arrowhead, its owner object is a horizontal line that runs through the shape's center.
- An arrowhead is oriented relative to the line it is assigned to, so a shape that is symmetrical and centered along a horizontal line gives best results.
- An arrowhead's owner line will extend to midpoint of the arrowhead shape unless a Backoff Point is specified.

Once an arrowhead has been converted to a CAD block, a Backoff Point can be added. This point is the location where the arrowhead's owner line ends and the arrowhead shape begins.

### *To add an Arrow Backoff Point*

1. Select an arrow CAD block and click the **Edit CAD Block**  edit tool. See [Edit CAD Block on page 330](#).
2. In the CAD Block window that opens, select **CAD> CAD Block> Add Arrow Backoff Point** .
3. A point marker will now follow the mouse pointer and you can click to place a Backoff Point. In most cases, the Backoff Point should be positioned along a horizontal line running through the center of the arrowhead shape.

When a Backoff Point is added to an arrowhead CAD block, an Insertion Point is also added at the block's midpoint. When an arrowhead is in use, its Backoff and Insertion Points are both located on imaginary line extending straight out from the owner object. You can, therefore, adjust the position of the Insertion Point to pivot the arrowhead about its Backoff Point:

- Move the Insertion Point upward in the CAD Block window to pivot the arrowhead shape downward when in use.
- Move the Insertion Point downward in the CAD Block window to pivot the arrowhead shape upward when in use.
- Move the Insertion Point to the left of the Backoff Point in the CAD Block window to reverse the direction of the arrowhead when in use.

Insertion Points have other uses, as well. See [Insertion Points on page 331](#).

---

## CAD Blocks

A CAD block is a group of 2D CAD objects, text objects, and/or dimensions that have been grouped together so that they behave as a single object. A CAD block can also contain other CAD blocks: these are referred to as “nested”.

CAD blocks can be imported into the program and can also be added to the library. See [Importing and Exporting on page 1222](#).

Dimension lines can only be included in a CAD block if they reference objects that are also included in the block. They will continue to inherit their attributes from the saved Dimension Defaults that they were associated with before the CAD block was created. See *Dimension Defaults Dialog on page 451*.

Terrain objects cannot be included in CAD blocks and, with the exception of a few CAD-based objects such as slabs, custom countertops and framing, CAD blocks cannot contain architectural objects. Such objects can instead be blocked in Architectural Blocks. See *Architectural Blocks on page 1007*.

CAD blocks can be selected, moved, rotated, resized, and deleted much like CAD boxes. They can also be exploded into their individual parts. See *Editing Box-Based Objects on page 232*.

A list of the CAD blocks present in the current file is available in the CAD Block Management dialog. See *CAD Block Management on page 333*.

## MAKE CAD BLOCK



To create a CAD block, group-select two or more eligible objects, and then click the **Make CAD Block** edit button. See *Marquee Select on page 213*.

Eligible CAD block component objects include:

- CAD objects
- Text objects
- Dimension lines
- CAD blocks
- CAD-based objects such as Slabs, Framing, and Custom Countertops.
- Distribution Paths and Regions that have CAD objects as their distributed object.

If the **Make CAD Block** edit button is not available, then the selection set may contain an object that is not an eligible CAD block component.

## EXPLODE CAD BLOCK



When a block is selected, click the **Explode CAD Block** edit button to separate it into its individual components.

If a CAD block includes nested blocks, these nested blocks are not exploded. They can, however, be selected and exploded separately.

When a selected CAD block is exploded, its definition is not affected: only the instance. See *CAD Block Definition on page 334*.

If a block has been resized so that its original aspect ratio is altered, it cannot be exploded. See *CAD Block Specification Dialog on page 334*.

## EDIT CAD BLOCK



The **Edit CAD Block** tool lets you make changes to a CAD block and then apply your changes to the selected CAD block instance or to all instances in the current plan or layout file. To access this edit tool:

- Select a CAD block or a symbol object that is represented by a CAD block in plan views. See *In Plan View on page 979*.

- Right-click on a CAD block or symbol represented by a CAD block in plan views in the User Catalog of the Library Browser. See *Using the Contextual Menu on page 951*.
- You can also select a CAD block in the CAD Block Management dialog and click the Edit button. See *CAD Block Management on page 333*.

When you click the **Edit CAD Block**  edit button, a CAD Block window opens. A copy of the selected block is created in that window, exploded into its component parts and ready to be edited. A CAD Block window is similar to a CAD Detail: the objects in the view can be selected and edited and the CAD, Text, and Dimension tools are available for use. See *CAD Details on page 337*.

Unlike regular CAD Details, however, neither the CAD Detail Management dialog, the CAD Detail from View tool, nor the Send to Layout tool are available when a CAD Block window is active. Layer settings in this view are customizable; however, when opened via the Library Browser, no changes are retained when the view is saved or closed. In addition, when you select **Tools> Active View> Save Active View** , the program updates the definition of the originally selected CAD block. If the selected block is present in a plan or layout file, a message box will first provide you with a count of all instances of it in the current file and will present you with a choice:

- Update **All Instances** of the CAD block in question throughout the current plan or layout file.
- Update **Only This Instance**, which refers to the instance that was selected when you clicked the **Edit CAD Block** button. When this option is used, a new CAD block definition is created and assigned to the selected block instance. The original CAD block definition is unchanged and remains assigned to any other CAD block instances in the plan that were using it. See *CAD Block Definition on page 334*.
- **Cancel** and do nothing.



## INSERTION POINTS

 By default, a CAD block has one Insertion Point located at its center. When placing the CAD block in a drawing or moving it to a new location, you can snap its Insertion Point to some other snap point for accuracy. See *Object Snaps on page 160*.

In some cases, it may be helpful to position a CAD block using an Insertion Point other than its center. For example, a CAD block representing a bolt or other fastener may be better positioned using the bottom center of its head or washer rather than its center. You can use the **Select Insertion Point**  edit button to replace the Insertion Point at the center with a different point.

Insertion Points can also be used to control the direction of custom arrowheads. See *Custom Arrowheads on page 329*.

### *To select an insertion point*

1. Make sure that **Object Snaps**  are enabled, then select the CAD block.
2. Click the **Select Insertion Point**  edit button.
3. Click at the location where you would like the Insertion Point.

The available snap points on a CAD block are located around the perimeter of its bounding box. If you need a different point, place a temporary **CAD Point**  at that location, and then snap to it when creating the Insertion Point.

A CAD block's Move edit handle displays at the location of its Insertion Point. If you place an Insertion Point at the midpoint of one of the bounding box edges, the Move edit handle may display instead of the Resize handle. CAD blocks also rotate about their Insertion Point.

You can also add an Insertion Point to a CAD block in its CAD Block window by selecting **CAD> CAD Block> Add Insertion Point** .

In addition, a CAD block's insertion point can also be specified relative to the block's center point in the CAD Block Specification dialog. See [General Panel on page 335](#).

## ADD TO LIBRARY

 Like a variety of other objects, CAD blocks can be added to the library for future use in other files. See [Adding Library Content on page 965](#).

Many manufacturers provide CAD details in DXF/DWG format. These drawings can be imported, blocked and added to the library. See [Importing 2D Drawings on page 1226](#).

If a CAD block contains an object on a custom layer or one that inherits properties from a Saved Dimension Default or Saved Text Style and that CAD block is placed from the library into a plan or layout file:

- That Saved Default, Text Style, or layer will be created in the destination file if it does not already exist.
- If a Saved Default, Text Style, or layer with the same name does exist in the destination file, the object will inherit its attributes from the existing settings.

See [Multiple Saved Defaults on page 79](#) and [Layers on page 176](#).

## CUSTOM 2D SYMBOLS

In plan views, 3D symbols and images are represented by 2D CAD blocks.

You can specify the CAD block used by a symbol in its Symbol Object Specification dialog. See [2D Block Panel on page 993](#).

The CAD block used by images and plant images is specified in the Image Specification dialog. See [Image Panel on page 1188](#).

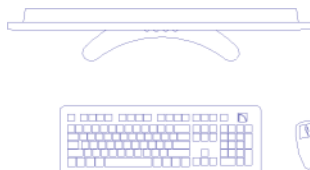

A CAD block representing a monitor,  
keyboard, and mouse

If you do not see an existing CAD block that suits your needs, you can create your own. For best results, follow these guidelines:

- The CAD block should have the same X and Y dimensions as the 3D symbol. An incorrect CAD block size will result in inconsistent placement of your symbol.
- It is usually best to build your CAD block with solid filled properties. This keeps background patterns and other objects from showing through. See [Fill Styles on page 192](#).
- So that your custom CAD block can be easily identified, assign it a short, descriptive name in the CAD Block Specification dialog. CAD blocks saved in the same plan or layout file must be unique: the program will append names with numbers to avoid duplicate names. See [General Panel on page 335](#).



CAD blocks that have nested blocks within them cannot be assigned to images.

# CAD Block Management

 A list of all CAD blocks present in the current plan or layout file can be accessed by selecting **CAD > CAD Block Management**.

The settings in this dialog are also found on the PLAN CAD BLOCKS panel of the Select CAD Block dialog for images and plant images. See *Image Panel on page 1188*.

## CAD BLOCK MANAGEMENT DIALOG

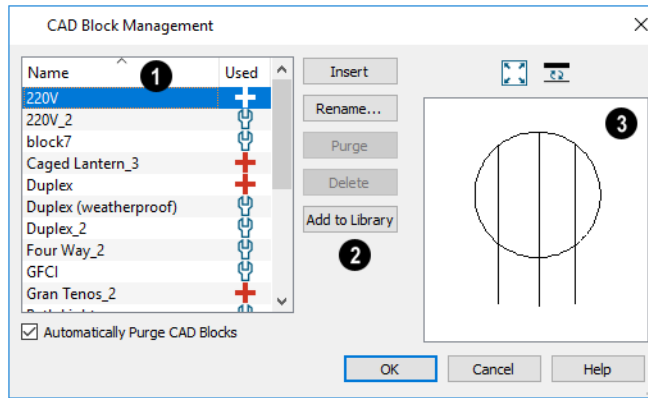

### 1 CAD Blocks

All CAD block definitions saved in the current file are listed here. CAD block definitions that currently have no instance anywhere in the file may be included.

Click on a column header to sort the table by the information in that column. An arrow above a header indicates that it is being used to sort the table, and in which direction it is being sorted.

- Click on the **Name** of a CAD block definition in the list to select it. The selected line item is highlighted in blue.
- CAD block definitions with at least one instance in the current file have a red plus **+** sign in the **Used** column, while those specified in a Defaults dialog have a white wrench  icon.
- Move your mouse pointer over an icon in the Used column for a summary of where the CAD block is in use. See *In Use Line Styles on page 201* for information about the different icons.
- Unused CAD block definitions with no instances in the current file have no icons in the Used column and can be deleted.
- When **Automatically Purge CAD Blocks** is unchecked and all instances of a CAD block are removed from the current file, its definition will continue to be saved in the file and will be listed here. Leave this box checked to remove unused CAD blocks from the list.

### 2 Management Options

The buttons on the right side of the list of CAD blocks allow you to manage the items in the list, as well as insert instances into the current view.

- Select one or more blocks in the list, click the **Insert** button, then click in the current view to place an instance of the block into that view. Not available in 3D camera views and overviews.

- Select a block in the list and click the **Edit** button to open a CAD Block Window where it can be edited. If multiple blocks are selected, a separate CAD Block Window is opened for each one. See *Edit CAD Block on page 330*.
- Select a block in the list, then click the **Rename** button to specify a new name for it.
- Click the **Purge** button to delete all unused block definitions from the list.
- Select an unused block and click the **Delete** button to remove it from the list. Not available for blocks that are Used.
- Click the **Add to Library** button to save a copy of the selected block in the User Catalog. See *Adding Library Content on page 965*.

### **3** Preview

A preview of the selected CAD block displays on the right side of the dialog. See *Dialog Preview Panes on page 22*.

## **CAD BLOCK DEFINITION**

There are two aspects to each CAD block:

- The block definition, which holds information about the block's component objects.
- The block instance, which holds information about its position, orientation, size, aspect ratio and other settings specific to an individual block placed in a file.

All instances of a given CAD block can have unique positions and sizes; however, the block definition that they share is the same regardless of the floor, view, or layout page that they display in.

Copying a block instance to a completely different file also copies the block definition to that file.

If all instances of a CAD block are deleted from a file, its definition will remain saved with the file. To control file size, it is a good idea to regularly purge files of unused CAD blocks or have the program do it for you automatically. Both options are available in the CAD Block Management dialog.

---

## **CAD Block Specification Dialog**



Select one or more CAD blocks and click the **Open Object** edit button to open the CAD Block Specification dialog.

## GENERAL PANEL

### 1 Name

Specify the CAD block’s **Name**. Not available when multiple CAD blocks are selected. If the CAD block has a copyright, information about it displays here.

This name is listed in the CAD Block Management dialog and is used when you export the block via DXF/DWG, and is also imported with DXF/DWG block definitions.

Unlike other settings in this dialog, which affect only the selected instance of the block, changing the name modifies the actual block definition. See *CAD Block Management on page 333*.

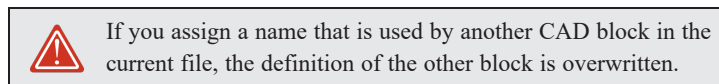

### 2 Position

Specify the **Position** and angle of the selected CAD block instance.

- Specify the **X and Y Positions**, which are the coordinates of the CAD block’s insertion point.
- Specify the **Angle** at which the CAD block instance is placed.

### 3 Line/Fill Style

Specify how line and fill styles are applied to the selected CAD block instance.

- Select **By Block Layer** to use the line and fill styles specified for the selected CAD block instance.
- Select **By Object** to use the line and fill styles of the individual objects in the selected CAD block instance.

New block instances use to By Block Layer unless **Use ‘By Object’ when creating new CAD blocks** is checked in the Preferences dialog. See [CAD Panel on page 114](#).

#### 4 Size

Specify the **Size** of the selected CAD block instance.

- Check **Retain Aspect Ratio of x** to retain the original ratio between the CAD block’s Height and Width. This only affects changes made in the dialog: it does not affect editing using the edit handles. If a block is resized so that its aspect ratio is changed, it cannot be exploded. See [Explode CAD Block on page 330](#).
- Specify the **Height** of the selected CAD block instance.
- Specify the **Height Factor**, which is the ratio of the current height of the CAD block instance to its original height.
- Specify the **Width** of the selected CAD block instance.
- Specify the **Width Factor**, which is the ratio of the current width of the CAD block instance to its original width.

Note: If the Height and Width Factors are set to different values, the selected CAD block instance cannot be exploded and ovals and arcs within it may appear distorted.

#### 5 Insertion Point (Relative to Center)

Specify the location of the selected CAD block instance’s **Insertion Point (Relative to Center)**. These offset values use the CAD block instance’s coordinate system rather than that of the drawing area, so if the block is rotated, its insertion point will remain in the same location relative to the block itself. See [Insertion Points on page 331](#).

- Specify the **X Offset**, the horizontal distance of the insertion point relative to the CAD block’s center point.
- Specify the **Y Offset**, the vertical distance of the insertion point relative to the CAD block’s center point.

#### 6 Copyright

Any **Copyright** information associated with the selected CAD block will be stated here.

#### LINE STYLE PANEL

Many of the settings on the LINE STYLE panel are only available if **By Block** is selected on the GENERAL panel of this dialog. For information about this panel, see [Line Style Panel on page 305](#).

#### FILL STYLE PANEL

The settings on the FILL STYLE panel are only available if **By Block** is selected on the GENERAL panel of this dialog. See [Fill Style Panel and Dialogs on page 193](#).

If **Always use “By Object” for CAD block fill style** is checked in the Preferences dialog, the settings on this panel are not used. See [CAD Panel on page 114](#).

#### LABEL PANEL

Labels for CAD blocks display when the “Polylines, Labels” layer is turned on and use the Text Style assigned to that layer. See [Text Styles on page 538](#).



For more information about the settings on this panel, see *Label Panel on page 700*.

## CAD Details

CAD Details are special view windows for drawing, saving and organizing 2D drawings associated with the current plan or layout file, such as site plans and section details. They are listed in the Project Browser and CAD Detail Management dialog, and can be created in both locations, as well. See *Project Browser on page 58*.

Like other views, CAD Details are saved in the file they are created in, have a specification dialog, use a Layer Set, and can be printed. CAD Details can also be sent to layout. A CAD Detail in a layout file can only be sent to layout pages in that same layout file. See *View Windows on page 144*.

2D CAD information can be copied into or out of a CAD Detail window using the group select and copy functions. See *Copying and Pasting Objects on page 167*.

### CAD DETAIL MANAGEMENT DIALOG



Select **CAD > CAD Detail Management** to open the CAD Detail Management dialog.

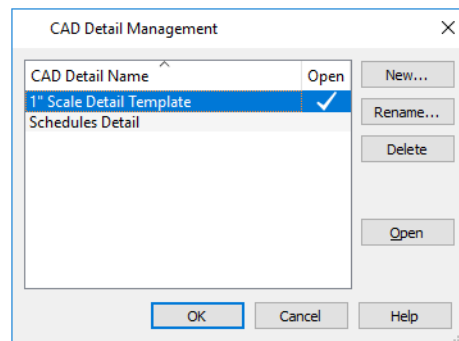



An alphabetical list of all CAD Details in the current file displays here.

- Click on a **CAD Detail Name** in the list to select it. The selected item's row is highlighted.
- If a CAD Detail is currently open, it will have a check mark in the **Open** column.
- Click **New** to open the Create New CAD Detail dialog. Type a short, descriptive name for the CAD Detail, click **OK**, and a new CAD Detail view window opens.
- To rename an existing CAD Detail, select it and click **Rename**.
- To create an exact copy of an existing CAD Detail, select it and click the **Copy** button.
- To delete a CAD Detail from the list, select it and click **Delete**. The automatically generated Truss Detail cannot be deleted if there are trusses in the current plan. See *Truss Details on page 901*.
- To open an existing CAD Detail, select it and click **Open**. CAD Details that are presently open have a check mark to the right of their name.

### SPECIAL CAD DETAILS

Some CAD details are created automatically by the program and function somewhat differently than regular CAD Detail windows:

- If any roof or floor trusses are present in a plan, the program creates a Truss Detail that includes an editable diagram of each truss type used and a count of each. See *Truss Details on page 901*.

- A Wall Detail is created for each wall with framing that has been automatically generated. Wall Details are listed in the Project Browser but not in the CAD Detail Management dialog. See [In Wall Detail Views on page 880](#).
- If you select a CAD Block and click the **Edit CAD Block**  edit button, the program creates a CAD Block window and pastes a copy of the block in that window where it can be edited. CAD Block windows are not listed in the CAD Detail Management dialog or in the Project Browser, however. See [Edit CAD Block on page 330](#).
- If you right-click on a Pattern in the library and select **Edit Pattern**  from the contextual menu, the program creates a Pattern window in which the pattern can be edited using CAD objects and edit tools. See [Editing Custom Patterns on page 197](#).
- If you select a Skylight and click the **Edit Skylight Shape**  edit button, the program creates a Skylight Detail window with a closed CAD polyline representing the skylight's shape. See [Edit Skylight Shape on page 835](#).

## CAD DETAIL FROM VIEW



**CAD> CAD Detail from View** converts the current view into a 2D CAD drawing composed of editable CAD objects.

**CAD Detail from View** is available in line-based views including most CAD Detail windows, plan views, and any 3D view using the Vector View Rendering Technique. It is not, however, available in CAD Block Windows. See [Rendered and Vector Views on page 1080](#).

Note: CAD Details are not dynamically linked to the model. Changes made to the view do not update in the detail or vice versa.

A CAD Detail created using **CAD Detail from View** inherits a variety of settings from the original view, including:

- The layer set used by the original view. See [Layer Sets on page 182](#).
- When the original view is a layout page with one or more layout boxes, a new "Layout Box Export Contents" layer is created for the contents of the layout boxes. See [Layout on page 1333](#).
- The Dimension Defaults settings used by the original floor plan or cross section/elevation view. See [Dimension Defaults Dialog on page 451](#).
- The rotation of the original view. See [Rotate Plan View on page 147](#).
- Any text objects using a specific Text Style in the original view will maintain the same settings in the CAD Detail; however they will use a Custom Text Style.

Camera views and overviews do not have Dimension Defaults, so the currently active defaults for plan view are inherited by CAD Details created from these types of views.

---

## CAD Detail Specification Dialog



To open the CAD Detail Specification dialog for any CAD Detail, right-click on its name in the Project Browser and select **Open Object** from the contextual menu. See [Project Browser on page 58](#).



You can also open this dialog for the currently active view by selecting **Tools> Active View> Edit Active View**.

## GENERAL PANEL

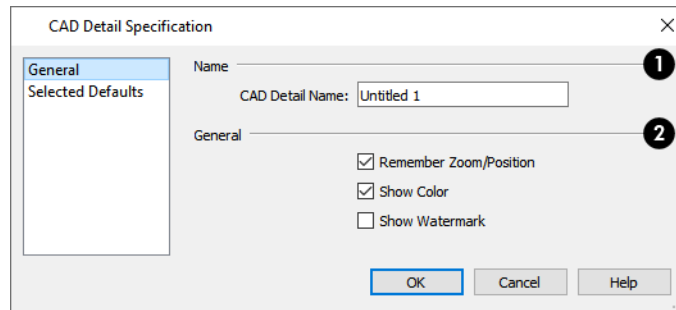

### 1 Name

Specify the **Name** of the view.

### 2 General

- Check **Remember Zoom/Rotation** to maintain the extents of the view and its rotation the next time the view is opened. See *Zoom Tools on page 153* and *Rotate Plan View on page 147*.
- Uncheck **Show Color** to turn color off in the selected view. See *Color On/Off on page 191*.
- Check **Show Watermark** to display the watermark specified for the current plan file in the selected view. See *Watermarks on page 1377*.

## SELECTED DEFAULTS PANEL

The settings on the **SELECTED DEFAULTS** panel control which Saved Defaults and layer settings are used in the view. These settings are also found in the Active Defaults dialog. See *Active Defaults Dialog on page 82*.

---

# Plot Plans and Plan Footprints

Using the CAD Tools and conventional survey information, you can create an accurate plot plan in plan view or a CAD Detail.

A plot plan can be sent to layout and included in construction documents. See *Dynamic Views on page 1341*.

A plot plan can also be converted into a terrain perimeter, allowing you to add elevation data and accurately position buildings for 3D modeling of home and lot.

## PLAN FOOTPRINT

-  Select **CAD> Plan Footprint** to create a CAD object representing the building footprint in a CAD Detail window. Once the Plan Footprint is created, you can control what information it displays.

### *To create a Plan Footprint*

1. Open the plan view that you want to create a Plan Footprint from.
2. Select **CAD> Plan Footprint** . The program creates a new CAD Detail with the footprint of the current floor.

- By default, this new CAD Detail uses the Plan Footprint layer set. You can control what displays in the footprint using the Layer Display Options dialog. See [Layer Sets on page 182](#).
- You can also control the appearance of a Plan Footprint in its specification dialog. See [Plan Footprint Specification Dialog on page 340](#).

### To insert a plan footprint in a CAD Detail

1. Open the CAD Detail in which you want to insert a Plan Footprint.
2. Select **CAD> Plan Footprint**.
3. Select the floor to use from the drop-down list and click **OK**.

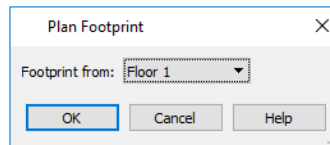

4. The floor plan appears in the CAD Detail window. Select **Window> Fill Window**  to center the footprint on screen.
5. The footprint can be rotated and moved anywhere in the window.

If the model consists of several buildings, a footprint is created for each. Moving one footprint automatically adjusts all the footprints in order to maintain their relationship.

If you edit a plan using **Reverse Plan**  or the **Edit Area**  tools, the plan footprint updates automatically.

Dimension lines can be drawn to locate the edges of a plan footprint polyline. Note that if changes to the plan cause the plan footprint polyline to update, any dimension lines that locate it may be deleted as a result. See [Dimensions on page 448](#).

## LAYER DISPLAY OPTIONS

When you create a plan footprint by selecting **CAD> Plan Footprint** while in plan view, the default layer set for Plan Footprints is used. See [Layer Set Defaults on page 183](#).

When a plan footprint is created by selecting **CAD> Plan Footprint** while in a CAD Detail, the current layer set is used. See [Layer Set Management on page 184](#).

Regardless of the layer set in use, the appearance of objects in a Plan Footprint is controlled in the Layer Display Options dialog. Individual objects are on the same layer as they are elsewhere, while the Plan Footprint itself is on the “CAD, Default” layer. See [Layer Display Options Dialog on page 179](#).

---

## Plan Footprint Specification Dialog



Select a plan footprint and click the **Open Object** edit button to open the Plan Footprint Specification dialog for the selected plan footprint.

## GENERAL PANEL

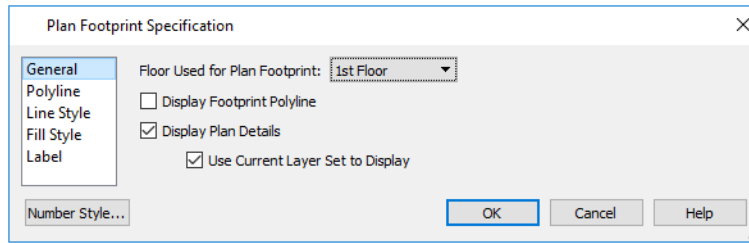

- Select the **Floor Used for Plan Footprint** from the drop-down list.
- Check **Display Footprint Polyline** to draw a polyline around the perimeter of the footprint. This option must be selected if you want to use a fill pattern or specify a line style. Note that the footprint polyline may not be visible if you also have Display Plan Details checked.
- Check **Display Plan Details** to show the walls and other details as they appear in plan view.
- Check **Use Current Layer Set to Display** to control what displays in the footprint using Layer Display Options. If you uncheck this box, you lose control of what displays and the program makes the determination for you. See [Layer Display Options on page 340](#).

## POLYLINE PANEL

The POLYLINE panel states the plan footprint polyline's **Perimeter** and its **Area**. See [Polyline Panel on page 317](#).

## LINE STYLE PANEL

The settings on the LINE STYLE panel do not affect the appearance of the plan footprint unless **Display Footprint Polyline** is checked on the GENERAL panel.

For information about using the LINE STYLE panel, see [Line Style Panel on page 305](#).

## FILL STYLE PANEL

The settings on the FILL STYLE panel do not affect the appearance of the plan footprint unless **Display Footprint Polyline** is checked on the GENERAL panel.

For more information about the FILL STYLE panel, see [Fill Style Panel and Dialogs on page 193](#).

# Walls, Railings, and Fencing

## Chapter 11

To draw a wall, select one of the *Wall Tools on page 347*, then click and drag in a line to the approximate length that you want. When you enclose an area with walls, a room is created, complete with floor and ceiling. The *Door Tools on page 545* and *Window Tools on page 577* can be used to add openings, while *Dimensions on page 448* are used to position walls and openings with accuracy.

Walls are the single most important structural component in Chief Architect. They define *Rooms on page 412*, are used to create *Foundations on page 705*, and even influence how *Roofs on page 791* are built. It is helpful to understand how Wall Type Definitions, wall connections, and wall alignment all affect your design.

### TOPICS

<b>Wall, Railing, and Fencing Defaults</b> .....	<b>343</b>
<b>Wall Tools</b> .....	<b>347</b>
<b>Railing and Deck Tools</b> .....	<b>349</b>
<b>Fencing Tools</b> .....	<b>351</b>
<b>Exterior and Interior Walls</b> .....	<b>351</b>
<b>Foundation Walls</b> .....	<b>352</b>
<b>Pony Walls</b> .....	<b>354</b>
<b>Room Dividers and Invisible Walls</b> .....	<b>355</b>
<b>Polygon Shaped Rooms and Decks</b> .....	<b>356</b>
<b>Wall Hatching</b> .....	<b>357</b>
<b>Creating Walls</b> .....	<b>357</b>
<b>Connecting Walls</b> .....	<b>361</b>
<b>Displaying Walls</b> .....	<b>363</b>
<b>Measuring Walls</b> .....	<b>366</b>
<b>Editing Walls</b> .....	<b>368</b>
<b>Edit Handles for Walls</b> .....	<b>372</b>
<b>Editing Straight/Curved Wall Combinations</b> .....	<b>374</b>
<b>Aligning Walls</b> .....	<b>375</b>
<b>Roof Directives in Walls</b> .....	<b>378</b>
<b>Attic Walls</b> .....	<b>380</b>
<b>Stepped and Raked Walls</b> .....	<b>381</b>
<b>Double Walls</b> .....	<b>382</b>
<b>CAD to Walls</b> .....	<b>383</b>
<b>Wall Type Definitions</b> .....	<b>384</b>
<b>Wall Type Definitions Dialog</b> .....	<b>387</b>
<b>Exporting and Importing Wall Types</b> .....	<b>391</b>
<b>Wall Specification Dialog</b> .....	<b>392</b>
<b>Railing and Fencing Specification Dialogs</b> .....	<b>406</b>
<b>Wall Hatching Specification Dialog</b> .....	<b>411</b>
<b>Wall Schedules</b> .....	<b>411</b>

---

## Wall, Railing, and Fencing Defaults

 There are several defaults dialogs for walls. Default Settings can be accessed by selecting **Edit > Default Settings**. Click the arrow next to “Walls” to display the walls sub-headings. Select a subheading and click the **Edit** button to open the Wall Defaults dialog associated with your selection:

The defaults dialog for each wall tool can also be accessed by double-clicking the tool’s toolbar button.

The settings in the various wall defaults dialogs determine what wall types are drawn when the different wall tools are used. It is a good idea to be familiar with these settings and how they relate to your style of building. See [Wall Type Definitions on page 384](#).

### SET AS DEFAULT

 You can set the attributes for a selected wall in your plan as a default wall type by clicking the **Set as Default** edit button. See [Set as Default on page 79](#).

Which Wall Defaults gets updated depends on the attributes of the selected wall. If the selected wall is specified as:

- A **Foundation** wall, its attributes will become the Foundation Wall Defaults.
- A **Slab Footing**, its attributes will become the Slab Footing Defaults.
- A Railing or Deck Railing that is not specified as **Solid** or set to **Follow Terrain**, its attributes will become the Railing or Deck Railing Defaults.
- A **Solid** Railing or Deck Railing, its attributes will become the Half Wall Defaults.
- A Railing or Deck Railing set to **Follow Terrain**, its attributes will become the Fencing Defaults.
- A wall specified as **Invisible**, its attributes will become the Room Divider Defaults.

If a wall does not have a setting listed above and defines:

- Only interior rooms, its attributes will become the Interior Wall Defaults.
- An exterior room or forms part of the structure’s exterior, its attributes will become the Exterior Wall Defaults.

The **Set as Default**  edit tool is not available for Pony Walls.

### GENERAL WALL DEFAULTS

 The General Wall Defaults dialog controls the general behavior and display attributes of all walls, railings and fencing.

For quick access, the **General Wall Defaults**  button can be added to the toolbar or you can press Alt+Q on your keyboard.

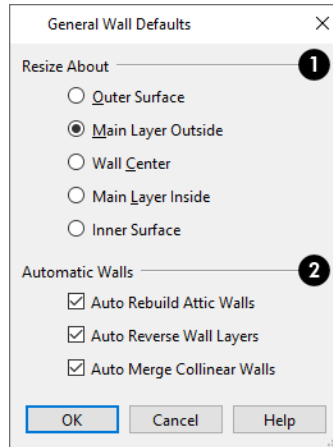

## 1 Resize About

These radio buttons determine what part of a wall retains its position when its wall type or wall type definition is changed. See [Resize About on page 375](#).

The **Resize About** location is also where any snap points will be located along a wall as it is drawn or connected to other walls, and is where a wall's length is measured.

- **Outer Surface** - Snap to and resize about the exterior surface. When a wall is resized, its exterior surface does not move.
- **Main Layer Outside** - Snap to and resize about the outer line of the Main Layer. When a wall is resized, the outer line of its Main Layer does not move. When multiple Main Layers are specified, the outer line of the outermost Main Layer is used.
- **Wall Center** - Snap to and resize about the center line. When a wall is resized, its center line does not move, but wall layers on either side may.
- **Main Layer Inside** - Snap to and resize about the inner line of the Main Layer. When a wall is resized, the inner line of its Main Layer does not move. When multiple Main Layers are specified, the inner line of the innermost Main Layer is used.
- **Inside Surface** - Snap to and resize about the interior surface. When a wall is resized, its interior surface does not move.

Note: In most circumstances, it is recommended that you Resize About the Main Layer Outside to avoid unexpected results.

## 2 Automatic Walls

- Uncheck **Auto Rebuild Attic Walls** to prevent Attic walls from automatically generating when the model changes. When checked, Attic Walls are automatically generated. See [Attic Walls on page 380](#).
- When **Auto Reverse Wall Layers** is checked, walls will automatically reverse their layers to ensure that exterior layers face the exterior of the structure. Uncheck this to leave the orientation of the wall layers unchanged. See [Creating Walls on page 357](#).
- When **Auto Merge Collinear Walls** is checked, collinear walls with the same wall type and specifications automatically merge to form a single wall. Uncheck this to force these walls to remain separate. See [Removing Wall Breaks on page 362](#).





## EXTERIOR AND INTERIOR WALL DEFAULTS DIALOGS

Specify the initial attributes of walls drawn using the **Exterior Wall**  and **Interior Wall**  tools in the Exterior and Interior Wall Defaults dialogs. See [Wall Tools on page 347](#).

The panels in this dialog are the same as their respective panels in the Wall Specification dialog. See [Wall Specification Dialog on page 392](#).

## FOUNDATION WALL DEFAULTS

Specify the initial attributes of walls created by the **Foundation Wall**  tool when it is either used manually or when a stem wall or pier foundation is generated in the Foundation Wall Defaults dialog. See [Foundation Walls on page 352](#).

The Foundation Wall Defaults dialog also controls the wall type drawn by the **Retaining Wall**  tool. Unlike other walls, **Retaining Walls**  are used to modify your terrain rather than build a structure. See [Terrain Wall and Curb Tools on page 1254](#).

Footing size and other information used when building stem wall or pier foundations is also specified here. For more information, see [Foundation Defaults Dialog on page 706](#).

The panels in this dialog are the same as their respective panels in the Wall Specification dialog. See [Wall Specification Dialog on page 392](#).

## SLAB FOOTING DEFAULTS

Specify the initial attributes of walls created by the **Slab Footing**  tool when it is either used manually or when a foundation is generated in the Slab Footing Defaults dialog. See [Foundation Walls on page 352](#).

Footing size and other information used when building a monolithic slab foundation is also specified here. See [Foundation Defaults Dialog on page 706](#).

The panels in this dialog are the same as their respective panels in the Wall Specification dialog. See [Wall Specification Dialog on page 392](#).

## PONY WALL DEFAULTS

Specify the initial attributes of walls drawn using the **Pony Wall**  tool. See [Pony Walls on page 354](#).

The **Display in Plan** and **Display of Openings in Non-Displayed Parts of Walls** settings on the WALL TYPES panel of the Pony Wall Defaults dialog are saved with and can be different in each Saved Plan View. See [Plan Views on page 146](#).

The panels in this dialog are the same as those in the Wall Specification dialog. See [Wall Specification Dialog on page 392](#).

## RAILING AND DECK RAILING DEFAULTS

Specify the types of railings created when the Railing and Deck Railing tools are used. See [Railing and Deck Tools on page 349](#).

Note: By default, Railings and Deck Railings are drawn using two separate wall types: “Interior Railing” and “Deck Railing/Fence”. See [Wall Type Definitions on page 384](#).

The panels in these dialogs are the same as their respective panels in the Wall Specification dialog. See [Wall Specification Dialog on page 392](#).

### GLASS WALL DEFAULTS

Specify the initial attributes of walls drawn using the **Straight Glass Wall**  tool. See [Glass Walls and Half-Walls on page 347](#).



The panels in this dialog are the same as their respective panels in the Wall Specification dialog. See [Wall Specification Dialog on page 392](#).

### GLASS PONY WALL DEFAULTS

Specify the initial attributes of walls drawn using the **Straight Glass Pony Wall**  tool. See [Glass Walls and Half-Walls on page 347](#).

The panels in this dialog are the same as their respective panels in the Wall Specification dialog. See [Wall Specification Dialog on page 392](#).

### HALF-WALL DEFAULTS

Specify the attributes of a solid railing drawn using either the **Straight Half Wall**  or **Curved Half Wall**  tool. See [Glass Walls and Half-Walls on page 347](#).

The panels in this dialog are the same as their respective panels in the Wall Specification dialog. See [Wall Specification Dialog on page 392](#).

### FENCING DEFAULTS

Specify the initial attributes of walls drawn using either of the **Fencing Tools** . See [Fencing Tools on page 351](#).

The panels in this dialog are the same as their respective panels in the Wall Specification dialog. See [Wall Specification Dialog on page 392](#).

### ROOM DIVIDER DEFAULTS

Specify the initial attributes of walls drawn using the **Room Divider**  tool. See [Room Dividers and Invisible Walls on page 355](#).

The panels in this dialog are the same as their respective panels in the Wall Specification dialog. See [Wall Specification Dialog on page 392](#).

### WALL HATCHING DEFAULTS

Specify the initial attributes of **Wall Hatching**  tool. See [Wall Hatching on page 357](#).

The panels in this dialog are the same as their respective panels in the Wall Hatching Specification dialog. See [Wall Hatching Specification Dialog on page 411](#).

## Wall Tools



Select **Build> Wall** to access the Wall Tools. The type of wall drawn by each wall tool is specified in its corresponding defaults dialog.



The **Curved Wall** tools are similar to their corresponding **Straight Wall Tools**. Select **Build> Wall** to access these tools as well.

### EXTERIOR WALLS



The **Exterior Wall** and **Curved Exterior Wall** tools draw walls using the default wall type specified for exterior walls in the Exterior/Interior Wall Defaults dialog. See [Exterior and Interior Walls on page 351](#).

### INTERIOR WALLS



The **Interior Wall** and **Curved Interior Wall** tools draw walls using the wall type specified for interior walls. The interior wall type is defined in the Exterior/Interior Wall Defaults dialog.

Note: Whether a wall is recognized as an exterior or interior wall by the program is determined by its position in the model, not by the tool used to draw it. See [Exterior and Interior Walls on page 351](#).

### FOUNDATION WALLS



The **Foundation Wall** and **Curved Foundation Wall** tools draw foundation walls according to the information specified in the Foundation Defaults dialog. Foundation walls normally have a footing and can be drawn on any floor of the model, not just the foundation floor. See [Foundation Walls on page 352](#).



The **Slab Footing** tool draws a single-layer concrete wall the same width as that specified for footings in the Foundation Defaults dialog. Rooms defined entirely by Slab Footings will have a Ceiling Height of 0 and a Monolithic Slab Foundation specified. See [Foundation Defaults on page 706](#).

### PONY WALLS



A **Pony Wall**, also called a split wall, is defined as a wall with two separate wall types, one for the upper portion and another for the lower portion.

The **Pony Wall** and **Curved Pony Wall** tools draw pony walls using the information specified in the Pony Wall Defaults dialog. You can also convert a normal wall into a pony wall and vice versa in the Wall Specification dialog. See [Pony Walls on page 354](#).

### GLASS WALLS AND HALF-WALLS



The **Straight Glass Wall** tool creates single-layer glass walls that do not cut the surfaces of the floor, ceiling, or adjacent walls. The wall type and other attributes of glass walls drawn with this tool are defined in the Straight Glass Wall Defaults dialog. See [Glass Wall Defaults on page 346](#) and [Partition Walls on page 362](#).



The **Straight Glass Pony Wall** tool creates a pony wall with a glass upper partition. The height and other attributes of walls drawn with this tool are defined in the Straight Glass Pony Wall Defaults dialogs. See [Glass Pony Wall Defaults on page 346](#).



The **Half-Wall** and **Curved Half-Wall** tools create solid railings: walls that are 36" (900 mm) high topped

with a handrail. The height and other attributes of solid railings drawn with this tool are defined in the Half-Wall Defaults dialog. See [Half-Wall Defaults on page 346](#).

## ROOM DIVIDERS

 **Room Dividers** are Invisible walls with a thickness of 0” (mm) that are used to define separate room areas in a plan. They can display in plan view but not in 3D views. See [Room Dividers and Invisible Walls on page 355](#).

## POLYGON SHAPED ROOM

 The **Polygon Shaped Room** tool opens the New Polygon Shaped Room dialog, where you can specify the exact size and number of sides of a new polygonal room and then click in plan view to create that room. See [Polygon Shaped Rooms and Decks on page 356](#).

## WALL HATCHING

 The **Wall Hatching** tool applies a hatch pattern to a wall that displays in plan views. You must click the wall that you want to apply the hatch pattern to. You can then select the hatch and resize it if you want to only hatch a portion of a wall. See [Wall Hatching on page 357](#).

## WALL MATERIAL REGIONS

 Select **Build> Wall> Wall Material Region** to create an area on a wall that has different materials than the wall. See [Floor and Wall Material Regions on page 1037](#).

## FIX WALL CONNECTIONS

 The **Fix Wall Connections** tool connects walls whose ends are within a few inches of each other but are not connected. See [Fix Wall Connections on page 362](#).

## WALL BREAK

 The legacy **Wall Break** tool divides walls into separate segments. It is similar to the Break edit tool, but can be used to modify multiple walls without having to select them first. The Wall Break tool has been deprecated but can be activated using the hotkey Ctrl + B. In addition, it may be available if legacy toolbars have been migrated into Version X15. It can also be added to the toolbars or assigned a custom hotkey if you wish. See [Add Break on page 254](#) and [Toolbars and Hotkeys on page 128](#).

## DEFINE WALL TYPES

 The **Define Wall Types** tool opens the Wall Type Definitions dialog, where wall types can be created, copied and edited. See [Wall Type Definitions Dialog on page 387](#).

## LIBRARY WALLS

 You can also add a wall to the library, and then draw a new wall in any plan using its wall type and specifications by simply selecting it and then clicking and dragging in the drawing area. See [Adding Library Content on page 965](#).

When a new wall is drawn, it inherits the wall type of the library wall. If a wall type of that name already exists in the plan and the two are not identical, a new wall type will be created in that plan, and its name appended with “\_2”. See [Wall Type Definitions on page 384](#).

## Railing and Deck Tools

 Railings are a special type of wall that have a specified height rather than building all the way to a room's ceiling height. Select **Build> Railing and Deck** to access the Railing and Deck Tools. Railings are typically used to define interior spaces, while the various Deck tools are used to define exterior Deck rooms.



With the exception of the Polygon Shaped Deck tool, each of the tools in this family have both Straight and Curved versions, and are created and edited just like walls. See [Creating Walls on page 357](#).

To create a break in a railing for a stairway or other access, use a **Doorway** . This keeps the railing continuous and maintains room definition. See [Room Definition on page 413](#).

When first drawn, railings are specified as **No Locate**, which prevents **Auto Exterior Dimensions**  from locating them. This attribute may also be helpful if you do not want a railing to divide an area into two separate rooms. See [General Panel on page 392](#).

The attributes for railings when they are first drawn are defined in the Railing Defaults dialog. See [Railing and Deck Railing Defaults on page 345](#).

### RAILINGS

  The **Railing** and **Curved Railing** tools create railings that are primarily used to define interior spaces. The style and height of railings drawn with this tool are defined in Railing Defaults dialog. See [Railing and Deck Railing Defaults on page 345](#).

Railings are ideal for a number of tasks:

- Creating changes in floor and/or ceiling height. See [Floor and Ceiling Heights on page 426](#).
- Creating stairwells. See [Creating a Stairwell on page 769](#).





### DECK RAILING

  The **Straight Deck Railing** and **Curved Deck Railing** tools draw decks, complete with framing and bounded by a railing. If a foundation level exists, supports for the deck are also created. See [Decks on page 425](#).

When a room is defined using deck railing, its **Room Type** is automatically set to "Deck". See [Decks on page 425](#).

### DECK EDGES

  The **Straight Deck Edge** and **Curved Deck Edge** draw decks complete with framing, but without a railing. No deck supports are created.



## POLYGON SHAPED DECK

 The **Polygon Shaped Deck** tool opens the New Polygon Shaped Deck dialog, where you can specify the exact size and number of sides of a new polygonal deck room and then click in plan view to create that deck room. See [Polygon Shaped Rooms and Decks on page 356](#).

## RAILING TYPES

A variety of railing types can be specified in the Railing and Deck Railing Specification dialogs. See [Rail Style Panel on page 407](#). Available types include:

- **Baluster** creates railings composed of newel posts, balusters, a railing, and an optional bottom rail.
- **Solid** produces a framed railing wall, or Half Wall. See [Glass Walls and Half-Walls on page 347](#).
- If **Panels** is selected, you can choose a panel style such as cable, glass, or ironwork from the library. See [Newels/Balusters Panel on page 409](#).

By default, newels and balusters do not display in plan view, but their display can be turned on. See [Newels/Balusters Panel on page 409](#).

## WALL TYPES AND RAILINGS

Just like regular walls, railings are assigned a wall type: “Interior Railing”. This wall type has three layers: a framing layer in the middle and a layer of drywall on each side. See [Wall Type Definitions on page 384](#).

You can use a different wall type definition for railings if you wish, but bear in mind that this wall type definition determines several important things:

- The railing’s appearance in plan view. See [Displaying Walls on page 363](#).
- The actual thickness of Solid railings in 3D views.
- The extent of the floor platform, if a platform edge is defined by the railing is defined by the outer surface of the wall type. See [Floor and Ceiling Platforms on page 428](#).
- If the railing is used to create a change in floor height, this wall type controls the structure and position of the partial wall built beneath the railing, if one is required. See [Floor and Ceiling Heights on page 426](#).

If the railing is a type other than Solid, its sizing is specified on the NEWELS/BALUSTERS panel of the Railing Specification dialog, and the railing is centered along the width of the wall type. This will not be evident in plan view unless newels and balusters are set to display.

Deck Railing is also assigned a wall type: “Deck Railing/Fencing”. This wall type has a single framing layer and is recommended for use only with deck railing and fencing.

## RAILINGS OVER WALLS

To produce a railing over a solid wall, specify it as both a Railing and a Pony Wall. See [Pony Walls on page 354](#).

To create a solid glass partition over a partial-height wall, specify the “Glass Shower” wall type as the Upper Wall.

### *To create a glass panel above a half wall*



1. Draw a **Half Wall**  and open its specification dialog.
2. On the WALL TYPES panel of the Railing Specification dialog, check the box beside **Pony Wall**.
3. On the WALL CAP panel, confirm that **Full Wall Width** is checked.
4. On the RAIL STYLE panel, select **Panel** and uncheck **Include Top Rail**, **Include Bottom Rail**, and **Raise Bottom**.
5. On the NEWELS/BALUSTERS panel, select “Solid” and adjust the Newels/Posts **Width** and **Spacing** values to meet your needs.
6. On the MATERIALS panel, specify a glass material for the Panel component.

---

## Fencing Tools

Fencing is a special type of wall that is designed to follow the terrain rather than define a room with a flat floor platform.

 Select **Build> Fencing** or click the **Fencing Tools** to access the fencing tools. Fencing automatically follows the shape of the terrain. You can choose to have the fencing follow the terrain smoothly or to have each segment step as it follows the terrain. See [Rail Style Panel on page 407](#).

  The **Fencing** and **Curved Fencing** tools are used to draw fences, which are similar to railings but by default do not define room areas. Fencing is created and edited much like walls and railings, and normally used outside a building and follows the shape of the terrain. See [Terrain on page 1243](#).

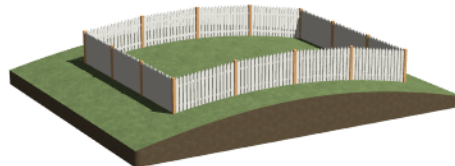



Define the default fence style in the Fencing Defaults dialog. See [Fencing Defaults on page 346](#).

---

## Exterior and Interior Walls

  Most walls are drawn using either the **Straight Exterior Wall** and **Straight Interior Wall** tools.

  Exterior and interior walls can also be drawn using the **Curved Exterior Wall** and **Curved Interior Wall** tools.

The only difference between the Exterior and Interior Wall Tools is the wall type used: Exterior Walls use a wall type set up to model a wall with siding, while Interior Walls model interior walls with sheetrock. See [Wall Type Definitions on page 384](#).

To draw a wall using a different wall type, you can change the default wall type for either tool in the Exterior and Interior Wall Defaults dialogs. You can also draw a wall using the default type and then change the wall type in the Wall Specification dialog. See [Wall Types Panel on page 402](#).

Whether a wall is recognized by the program as an actual exterior or interior wall is based on its position in the model, not by which tool you used to draw the wall.

- Any wall or wall segment that is entirely surrounded by interior room areas is considered to be an interior wall.
- Any wall or wall segment that defines an exterior room or is exposed to the outside of the building is considered to be an exterior wall. See [Room Types and Functions on page 415](#).

For some purposes, a wall is considered to be exterior based on whether it forms part of the Thermal Envelope that surrounds the plan's Conditioned Area. For example, a Framed wall that separates Conditioned Area from Unconditioned Area will be included when Thermal Envelope information is exported to REScheck. It will also have insulation counted in the Materials List. See [Exported Envelope Data on page 1241](#) and [In the Materials List on page 365](#).

---

## Foundation Walls



Foundation walls are similar to the interior and exterior walls but also have a footing. Foundation walls can either be created automatically when a foundation floor is created or manually by drawing them using the **Straight** or **Curved Foundation Wall** tool. See [Building a Foundation on page 710](#).



The initial foundation wall type and footing size are specified in the Foundation Wall Defaults dialog. These values can be changed for individual walls in the Wall Specification dialog. See [Wall Specification Dialog on page 392](#).

You can draw a foundation wall on any floor of a plan, not just on the foundation level. Any wall can be specified as a foundation wall, regardless of the tool used to draw it. See [Foundation Panel on page 400](#).

Foundation walls are placed on the "Walls, Foundation" layer by default, but can be put on any layer you choose. In plan view, foundation wall footings are placed on the "Footings" layer and cannot be moved; in 3D views, they are on the "Walls, Foundation" layer. See [Displaying Walls on page 363](#).

### SLAB FOOTING



The **Slab Footing** tool draws a single-layer concrete wall using the wall type and other attributes specified in the Slab Footing Defaults dialog. Slab Footings are used to define Monolithic Slab foundations, garage curbs, and interior footings. Typically, that wall type should have the same width as that specified for footings. For Garage curbs, the footings should be wider than the wall type. See [Foundation Panel on page 400](#).

Rooms defined by Slab Footings will have a Ceiling Height of 0 and a Monolithic Slab Foundation. See [Structure Panel on page 439](#).



## FOUNDATION WALL FOOTINGS

Normally, a foundation wall's footing is centered on the wall. If you prefer, you can:

- Center the footing on the main wall layer.
- Align the footing along the wall's exterior.
- Specify an offset, as measured from the wall's center line.

These offset options are set in the Wall Specification dialog. See [Foundation Panel on page 400](#).

You can select the footing in 3D views and edit its size and shape using the edit handles. See [Stepped and Raked Walls on page 381](#).

Foundation wall footings extend past the end of a foundation wall the same amount that they extend past each side when centered on the wall.

To create a footing that extends more than that amount, create a short segment of foundation wall at that location and specify it as Invisible.

## BRICK LEDGES

Brick ledges can be produced in monolithic slab, stem wall, and grade beam foundations. They do not extend under door openings in monolithic slab foundations.

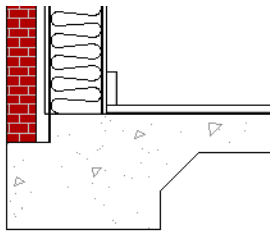

Brick ledges are represented in plan view by lines on the "Brick Ledge Lines" layer. See [In Plan View on page 363](#).

In order for a brick ledge to be produced, the foundation wall material directly under the brick ledge must be the "Concrete" Structure Type and the wall material that drops into the brick ledge must be the "Masonry" Type. See [Material Structure Types on page 1063](#).

In addition, the Wall Type Definition for the foundation wall must have a **Brick Ledge Depth** value greater than zero. See [Wall Type Definitions on page 384](#).

Additional settings that control whether a brick ledge is produced as well as its size are found in the Wall Type Definition of the wall that is located above the brick ledge.

- The width of the ledge is equal to that of the Exterior Layers of the wall type.
- The **Foundation to Exterior of Layer** setting must be the wall type's exterior layer.
- The **Build Platform to Exterior of Layer** setting cannot be the wall type's exterior layer.

If the floor platform inside a brick ledge is hung on the foundation wall, **Subflooring to Wall Interior** must be checked in the Wall Specification dialog in order for a brick ledge to generate. See [Structure Panel on page 395](#).

## Pony Walls



A **Pony Wall**, sometimes called a split wall, is a wall with two separate wall types, one above the other.

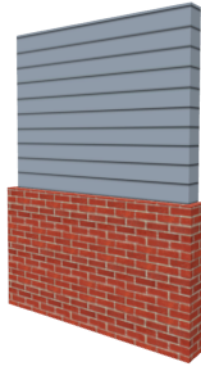

Walls drawn using the **Pony Wall**  tool are created using the wall types and other information specified in the Pony Wall Defaults dialog. See [Pony Wall Defaults on page 345](#).

Most pony walls combine two exterior or two interior wall types; however, a pony wall can also produce an individual wall to be an exterior wall near its top and an interior wall near its bottom. See [Exterior/Interior Pony Walls on page 379](#).

When a pony wall is also specified as a Railing, its upper wall is replaced by a railing. See [Wall Types and Railings on page 350](#).



You can also convert a normal wall into a pony wall and vice versa in the Wall Specification dialog. See [Wall Types Panel on page 402](#).

The height where the upper portion meets the lower can be adjusted in 3D views using the wall's edit handles as well as in the Wall Specification dialog. The upper and lower sections of a pony wall are linked, so if either portion is modified along the division between the two, the other portion of the pony wall adjusts to match. See [Stepped and Raked Walls on page 381](#).

### DISPLAYING PONY WALLS

You can specify whether the upper and lower portion of pony walls displays in plan view in the Pony Wall Defaults dialog. This **Display in Plan** option can also be set for individual walls in the Wall Specification dialog. See [Wall Types Panel on page 402](#).

Just as with other walls, the appearance of the portion of a pony wall that displays in plan view can be controlled. See [Displaying Walls on page 363](#).

Only the portion of a pony wall that displays can be snapped to; however, regardless of what part is displaying, the upper wall will be used to **Align with Wall Above** , and the lower part will be used to **Align with Wall Below** . See [Editing Walls on page 368](#) and [Aligning Walls on page 375](#).

By default, when a door or window is located entirely in one part of a pony wall, and that part is not displayed in plan view, the opening's outline is shown but the wall's layer lines and fill drawn through it. You can instead display openings in the non-displayed parts of pony walls the same as in the displayed parts, or not at all. See [Pony Wall Defaults on page 345](#).

If a window or door is completely contained by one part of a pony wall, it will display in plan view if the other part of the pony wall is shown; but the wall's layer fill pattern or Wall Hatching fill pattern will display over it.

The **Display in Plan** and **Display of Openings in Non-Displayed Parts of Walls** settings on the WALL TYPES panel of the Pony Wall Defaults dialog are saved with and can be different in each Saved Plan View. See [Plan Views on page 146](#).

## LOWER PONY WALL CAPS

You can specify a cap over the top of a lower Pony Wall. See [Wall Cap Panel on page 404](#).

By default, the cap generates on the exterior side of a Pony Wall, outward from the surface of the upper wall. This detail is sometimes referred to as a “water table”.

You can also specify that the cap build between the two parts of the Pony Wall, splitting them, as well as span the full width of the wall, which is the default for Pony Walls with Railings above. See [Railings Over Walls on page 351](#).

## CHANGING WALL TYPES

The default upper and lower parts of a Pony Wall can be specified in the Pony Wall Defaults dialog. See [Pony Wall Defaults on page 345](#).

The upper and lower parts of a Pony Wall can be redefined as different wall types in the Wall Specification dialog. See [Wall Types Panel on page 402](#).

---

# Room Dividers and Invisible Walls

 The **Room Divider** tool is used to define separate room areas in a plan; typically, by dividing a large room area into two or more smaller areas. See [Room Definition on page 413](#).

Common uses for Room Dividers include dividing areas of an open floor plan into areas with different purposes.

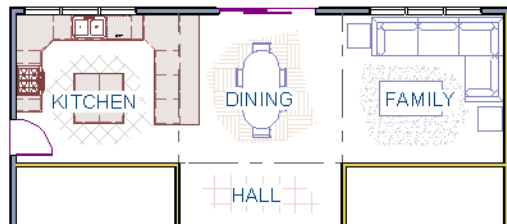



Room Dividers can also be used to define areas with different floor or ceiling materials or heights.

**Room Dividers**  are drawn using the attributes specified in the Room Divider Defaults dialog; which means they are simply walls that are specified as Invisible and have a single layer of an “Air Gap” material with a thickness of 0” (mm).

If a zero-thickness **Room Divider**  separates two rooms with different floor and/or ceiling heights, its wall type will be changed to the current plan’s default Interior Wall so that the platform step created by the height difference can be enclosed. See [Floor and Ceiling Platforms on page 428](#).

## INVISIBLE WALLS

Any wall, regardless of its wall type or thickness, can also be specified as Invisible - or vice versa - in the Wall Specification dialog or by clicking the **Make Wall(s) Invisible**  or **Make Wall(s) Visible**  edit button. See [General Panel on page 392](#).

Room Dividers are placed on the “Walls, Invisible” layer by default, as are walls that are specified as Invisible. A wall placed on a non-default layer and then specified as Invisible, however, will not move to the “Walls, Invisible” layer. See [Room Divider Defaults on page 346](#).

Walls specified as Invisible can display in plan view but not in 3D views or the Materials List. See [Displaying Walls on page 363](#).

It is not possible to place doors or windows into an Invisible wall; however, if a wall with openings in it is specified as Invisible, any openings in it will remain.

### IMPORTANT NOTES ON INVISIBLE WALLS

- Floor, wall and ceiling areas are calculated separately for rooms divided by Invisible walls.
- Invisible walls are ignored by the **Auto Place Outlets**  tool; it functions as though they were not present.
- Cabinets, fixtures and furniture can be moved freely through Invisible walls.
- Invisible walls can be drawn through a cabinet to attach to the wall behind.

---

## Polygon Shaped Rooms and Decks

The **Polygon Shaped Room** and **Polygon Shaped Deck** tools allow you to create rooms with regular sides and work similar to the **Regular Polygon**  CAD tool. See [Regular Polygon on page 319](#).



Select **Build> Wall> Polygon Shaped Room** to open the New Polygon Shaped Room dialog and create a polygon shaped room with regular sides.



Select **Build> Railing and Deck> Polygon Shaped Deck** to open the New Polygon Shaped Deck dialog and create a polygon shaped deck with regular sides.

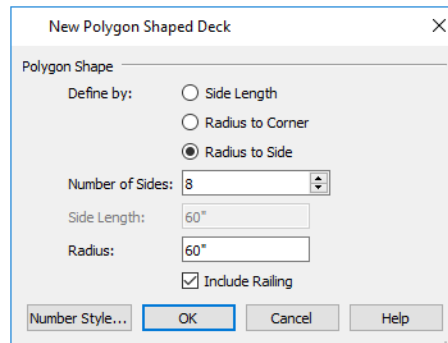

The settings in these two dialogs are identical and are saved between program sessions. They are also independent of one another so different settings can be retained for each.

### *To create a polygon shaped room or deck*

1. Click the radio button beside an option to specify whether you want to **Define Polygon by Side Length, Radius to Corner** or **Radius to Side**.
2. Specify the desired **Number of Sides**.
3. Specify the desired **Side Length** or,
4. Specify the desired **Radius**.

5. Uncheck **Include Railing** to produce a deck platform defined by Deck Edges. This option is not available in the New Polygon Shaped Room dialog.
6. Click **OK**, then click once in plan view to create the specified polygon shaped room or deck.

---

## Wall Hatching

 The **Wall Hatching** tool can be used to fill wall segments with a single hatch pattern in plan view. To apply wall hatching, select **Build> Wall> Wall Hatching**, then click on a wall. The hatch pattern covers the entire length and width of the wall segment.

Note: The Wall Hatching tool cannot be used to apply a hatch pattern to Invisible Walls or to walls on a locked layer. See *Room Dividers and Invisible Walls on page 355* and *Locking Layers on page 178*.

**Wall Hatching** places a hatch pattern across all layers of the selected wall layers displaying in the current view, covering any fill styles specified for that wall type. When wall hatching is applied to a railing, or when the “Walls, Main Layer Only” layer is turned on, wall hatching only displays in the Main Layer(s). See *The Main Layer on page 385*.



In many cases, it is preferable to create a wall type definition rather than use the **Wall Hatching** tool because multiple fill styles can be used. See *Wall Type Definitions Dialog on page 387*.

Wall hatching can be selected, edited and deleted much like other line-based objects. See *Editing Line-Based Objects on page 216*.

The initial appearance of wall hatching can be specified in the Wall Hatching Defaults dialog. Once created, the wall hatch pattern and its line weight can be customized in the Wall Hatching Specification dialog. See *Wall Hatching Specification Dialog on page 411*.

If you use the **Wall Hatching** tool to apply a hatch pattern to a wall that has been divided into multiple segments using the **Add Break**  edit tool, the pattern is only applied to the segment that you clicked on. See *Add Break on page 254*.

Like doors and windows, wall hatching must be placed within a single wall segment but can be edited to extend across multiple collinear wall segments after it is created. Unlike doors and windows, only the midpoint of Wall Hatching can be located by dimension lines.

If three or more wall hatching objects occupy the same space in a wall, a Caution  symbol will display at the problem location in plan view. Click on the Caution  symbol that displays over the wall to open a contextual menu, then select **Delete** to delete a duplicate wall hatching. When no more Caution symbols remain, you should then confirm that the remaining two wall hatching objects meet your needs and delete any that are unnecessary.

When editing or deleting wall hatching, make sure that it is selected rather than the wall by noting that “Wall Hatching” displays in the Status Bar. See *The Status Bar on page 24*.

---

## Creating Walls



Walls, railings, and fencing are drawn similar to the way CAD lines are drawn: select a Wall Tool or a wall saved in the Library Browser, and then click and drag from end to end in the drawing area by clicking and dragging from end to end. Walls can be drawn in plan view, camera views, and overviews. See *Line Tools on page 300*.

There are several other ways that walls can be created in Chief Architect:

- Exterior walls can be generated automatically when a new floor is built by using another floor as a model. See *Adding Floors on page 732*.
- Foundation walls are created when a foundation is automatically generated on Floor 0. See *Foundations on page 705*.
- Attic walls are generated automatically when the program perceives a gap between a wall that defines a room and the roof above. See *Attic Walls on page 380*.
- The **Space Planning Assistant** creates room boxes which can be arranged and then converted into walls. See *Space Planning on page 62*.
- 2D CAD lines can be converted into walls using the **CAD to Walls** tool. See *CAD to Walls on page 383*.



## DRAWING WALLS

Drawing walls to create a floor plan is simple if you keep a few things in mind:

- Draw exterior walls first to define the building's footprint, then draw the interior walls after the perimeter is in place.
- It is easiest to draw walls at the approximate location and length needed and then move or resize them precisely using dimensions later. See *Moving Objects Using Dimensions on page 483*.
- When drawing and positioning exterior walls, make sure **Grid Snaps**  are enabled. Once these walls are in place, you may prefer to turn Grid Snaps off to draw and position interior walls and other objects. See *Grid Snaps on page 163*.
- If you wish to input wall lengths as you draw, make sure your General Wall Defaults are set to **Resize About Outer Surface**. See *Entering Wall Lengths and Angles on page 359*.
- As walls are drawn, Intersection Snap indicators, “sticky” points and extension lines identify points that are either collinear or orthogonal to the end points of other walls, making alignment easier. See *Wall Intersection Extension Snaps on page 161*.
- As walls are drawn, Angle Snaps take priority over Object Snaps. If you prefer that walls draw at any angle so that they can snap to other objects, uncheck **Always Snap Walls On Allowed Angles** in the Preferences dialog. See *Snap Properties Panel on page 119*.
- When walls enclose an area to form a room, the program will orient all exterior walls so that the siding material faces outward. You can disable this behavior if you wish. See *Interior and Exterior Surfaces on page 386* and *General Wall Defaults on page 343*.
- To flip the layers of a wall after it is drawn, select it and click the **Reverse Layers**  edit button. See *Editing Walls on page 368*.
- Initial wall heights are determined by the default floor and ceiling heights of the current floor. See *Floor Defaults Dialog on page 731*.

## WALL ANGLES

With very few exceptions, walls should be drawn and edited with **Angle Snaps**  enabled. Walls that are drawn at irregular angles can result in wall connection, alignment, and room definition problems.

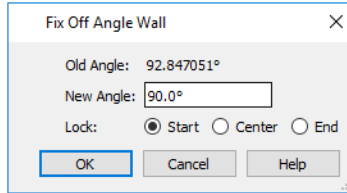

If a wall is drawn at an off angle, the **Off Angle Wall**  icon will follow the mouse pointer and a Caution  symbol will display over the problem wall in plan view. See *Pointer Icons on page 16*.

To correct the wall's angle, click on the Caution  symbol that displays over the wall and select **Fix Off Angle Wall** from the contextual menu. In the Fix Off Angle Wall dialog:



- The **Old Angle** is stated for reference.
- Enter a **New Angle** in the text field.
- Specify whether to **Lock** the **Start**, **Center**, or **End** point of the wall when its angle is changed.

There are several other ways to fix a selected wall if it has been drawn at an off angle:

- Click the **Open Object**  edit button and specify the correct angle. See *General Panel on page 392*.
- Click and drag an end edit handle until the wall snaps to an Allowed Angle. See *Angle Snaps on page 162*.
- If the wall in question should be aligned with a wall directly above or below it, click the **Align with Wall Above**  or **Align with Wall Below**  edit button. See *Aligning Walls on page 375*.

You can also suppress the Caution symbol by specifying the needed angle in the wall's specification dialog or adding that angle to the list of Allowed Angles. See *General Plan Defaults Dialog on page 92*.

Although not recommended unless the walls in question are Fencing, Terrain Walls, and/or Retaining Walls, you can choose to **Ignore Off Angle Wall** or **Ignore All Off Angle Walls** by clicking on the Caution  symbol that displays over an off angle wall. See *Fencing Tools on page 351* and *Terrain Wall and Curb Tools on page 1254*.

## WALL POSITIONING

The recommended method of drawing walls is to draw them at their approximate location and length, then move them into position with accuracy using dimensions. To make this task quick and efficient:

- Notice the temporary wall that displays as you draw. Its length and angle display in the Status Bar at the bottom of the window and adjust as you move the mouse. Release the mouse button to draw the wall at the displayed length and angle. See *The Status Bar on page 24*.
- Use Snaps to help ensure proper wall alignment and orientation. See *Snap Behaviors on page 159*.

Once walls are drawn, they can be accurately dimensioned and moved as needed. See *Measuring Walls on page 366*.

## ENTERING WALL LENGTHS AND ANGLES

The fastest way to draw walls is to draw them at their approximate position and length, and then move or resize them accurately using dimensions. See *Using Dimensions on page 369*.

For those that wish to enter walls' lengths and angles as they are drawn, first select **Resize About Outer Surface** in the General Wall Defaults dialog. See *Resize About on page 375*.

Then draw a wall, select it, and specify its **Length** and **Angle** in the Wall Specification dialog. Draw a second wall and specify its length and angle, and so on. See *General Panel on page 392*.

You can also press the Tab key while you are dragging to draw a wall to open the Enter Coordinates dialog, where you can enter the wall's **Distance**, or length, and **Angle**. See *Entering Coordinates on page 166*.

## WALL OPENINGS

To create a door or doorway, do not draw wall sections with a gap between them. Walls should be drawn to completely enclose rooms, and then door and window objects should be placed in the walls to create openings later. See [Doors on page 543](#) and [Windows on page 576](#).

## TEMPORARY DIMENSIONS

 Temporary dimensions will display along the length of a wall as it is drawn when **Temporary Dimensions** are toggled on. See [Temporary Dimensions on page 473](#).

## CONTINUOUS WALL DRAWING

You can draw walls continuously by right-clicking, Alt+clicking or Alt+dragging. See [To draw continuous lines on page 300](#).

By default, this continuous drawing behavior will turn off when walls are drawn to form an enclosed area. You can specify that this behavior remain on in the Preferences dialog. See [Behaviors Panel on page 118](#).

## DRAWING CURVED WALLS

Drawing a curved wall, curved railing, or curved fence is similar to drawing a CAD arc. See [Arc Tools on page 309](#).

As with CAD arcs, the method used to draw a curved wall depends on which **Arc Creation Mode**  is currently active. See [Drawing Arcs - Arc Creation Modes on page 307](#).

A straight wall can also be converted into a curved wall and vice versa using the **Change Line/Arc**  edit button. See [Change Line/Arc on page 256](#).

 To create a room in the shape of a circle, you must draw two curved walls.

A curved wall always has a center point. The center displays as a small cross when **Show Arc Centers and Ends**  is enabled. See [Arc Centers and Ends on page 223](#).

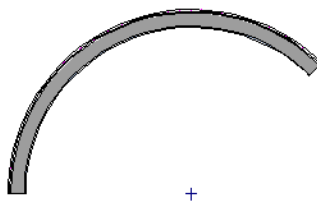

The radius of a curved wall is measured from the center to a surface or layer of the wall. The radius can be defined in the Wall Specification dialog. You may elect to define the radius to the exterior or interior wall layers. See [General Panel on page 392](#).

## SPACE PLANNING ASSISTANT

 The **Space Planning Assistant Tools** allow you to place and arrange room boxes that can then be converted into a fully editable house plan, including walls. See [Space Planning on page 62](#).



## WALL FRAMING

Once walls have been drawn, they can be framed. For best results, avoid generating framing until your model is in its final form. See [Wall Framing on page 852](#).

Framing for an individual wall can be built or rebuilt using the **Build Framing for Selected Object**  edit tool. This tool is only available if the selected wall has a framing material assigned to its Main Layer, and is not available if Retain Wall Framing is checked in the Wall Specification dialog. See [Build Framing for Selected Object\(s\) on page 885](#).

Once created, wall framing can be viewed and edited in floor plan and 3D views, as well as in **Wall Detail**  views. See [In Wall Detail Views on page 880](#).

---

## Connecting Walls

When walls are drawn sufficiently close to one another, they will snap together to form an intersection. This snapping occurs when the walls' center lines are within a distance defined by the larger of the two walls' widths and will occur even when **Object Snaps**  are turned off. See [Object Snaps on page 160](#).

If the two walls in question have identical specifications and are collinear, they will merge to become a single wall. See [Aligning Collinear Walls on page 375](#).

When three or more walls connect to form a completely enclosed area, that area defines a room. See [Rooms on page 412](#).

When walls snap together to form an intersection and **Object Snaps**  are enabled, the program joins them at their **Resize About** line, which is specified in the General Wall Defaults dialog. See [Aligning Walls on page 375](#).

- The wall that is being drawn or edited will move, lengthen, or shorten slightly to meet the other wall.
- The other wall will not move; however, its length may be affected.

## WALL INTERSECTIONS

Any time two walls intersect, one wall will build through the other. You can turn on the display of the “Walls, Through Wall Lines” layer in plan view to see which walls build through and which do not. See [Layer Attributes on page 177](#).

When a wall builds through another wall, it will extend into the intersected wall until it meets the interior surface of that wall's Main Layer. See [The Main Layer on page 385](#).

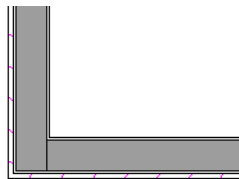

You can specify which walls build through wall intersections at corners in the Wall Specification dialog. See [Structure Panel on page 395](#).



You can also control how the individual layers of one wall build into another using the **Edit Wall Layer Intersections**  edit tool. See [Wall Layer Intersections Edit Handles on page 373](#).

## PARTITION WALLS

By default, walls not only build to an intersecting wall's Main Layer, they also build through the finish layers of the floor below and the ceiling above to reach the structural layers.

In some situations, though, this is not desirable: for example, glass shower walls are typically installed against the surfaces of walls, floors and ceilings rather than building into them. To achieve this, use a wall type that is specified as a **Partition Wall**. See [Wall Type Definitions Dialog on page 387](#).

## FIX WALL CONNECTIONS

 Occasionally, intersecting walls may not properly connect. When this is the case and the connection in question is on the current floor, a Caution  symbol will display at the problem location in plan view and the Connect Walls  icon will follow your mouse pointer.

Click on the Caution  symbol that displays over the wall to open a contextual menu:

- Select **Delete** to delete the wall.
- Select **Ignore Unconnected Wall** to leave the wall unchanged and suppress the Caution symbol.

To correct wall connections throughout the current plan, select **Build> Walls> Fix Wall Connections** .

Alternatively, you can fix an individual wall connection using the **Connect Walls**  edit tool.

### *To use the Connect Walls edit tool*

1. Select a wall.
2. Click the **Connect Walls**  edit button.
3. Click on a wall that you want to connect to the selected wall.
  - If the unconnected wall ends are sufficiently close to one another, the tool connects them.
  - If the separation is too great, extend one towards the other and try again.

## REMOVING WALL BREAKS

The **Add Break**  edit tool allows you to break a wall into two or more separate wall segments. See [Add Break on page 254](#).

To merge two collinear walls separated by a break, select one of the segments, then click the end edit handle located at the break and drag it a few plan inches (mm) away from the break.

If the two walls do not merge, either the walls are not collinear or their specifications are not identical. You can open the Wall Specification dialog for each wall and determine how they differ. See [Wall Specification Dialog on page 392](#).

You can prevent collinear walls from merging by unchecking **Auto Merge Collinear Walls** in the General Wall Defaults dialog. Turning this option off is useful when representing panelized walls. See [General Wall Defaults on page 343](#).

## Displaying Walls



While the structure and appearance of each wall type is controlled in the Wall Type Definitions dialog, the display of walls in all views is controlled in the Layer Display Options dialog. See [Layer Attributes on page 177](#).

The program installs with a number of layers intended for specifically for various types of walls; however, you can specify any layers as the defaults for most of these walls. Once created, you can also place a selected wall on any layer. See [Layer Panel on page 405](#).

If a “Walls” layer is turned off in plan view, any doors and windows placed in walls on that layer will not display, either. See [Displaying Doors on page 548](#) and [Displaying Windows on page 586](#).

### IN PLAN VIEW

The appearance of each wall type, including line weights and colors and wall layer fill styles, is specified in the Wall Type Definitions dialog. See [Wall Type Definitions Dialog on page 387](#).

In addition, a separate custom fill style can be specified for the footings of foundation walls. See [Foundation Panel on page 400](#).

There are also several options for controlling how walls are displayed in plan view. In the Layer Display Options dialog, you can specify whether or not various types of walls display.

- By default, walls are placed on layers with “Walls” at the beginning of the layer name, such as “Walls, Normal”.
- The display of the wall layers specified in the Wall Type Definitions dialog can be controlled. If you turn off the display of the layer called “Walls, Layers”, wall types display with two lines representing the inside and outside surfaces.
- In addition, you can turn off the display of non-structural layers and show only the walls’ Main Layers by turning on the display of the “Walls, Main Layer Only” layer. This allows you to create both fully configured walls and framing layouts. The “Walls, Main Layer Only” layer affects the display of walls in plan view only. See [The Main Layer on page 385](#).
- The “Walls, Through Wall Lines” layer controls the display of lines indicating which walls build through at wall intersections.
- Foundation Walls have footings that display in all view when the “Footings” layer is turned on. You can place footings on a custom layer if you wish. See [Displaying Foundations on page 711](#).
- Foundation Walls may also have brick ledge lines that display in plan view when the "Brick Ledge Lines" layer is turned on. See [Brick Ledges on page 353](#).

Note: In plan view, railings not specified as Solid display their Main Layer regardless of whether “Walls, Layers” or “Walls, Main Layer Only” is turned on. See [Wall Types and Railings on page 350](#).





Either the upper or lower portion of a Pony Wall can display in plan view. Only the portion that displays can be snapped to or aligned with walls above or below. See [Pony Walls on page 354](#).

Railing newels, balusters, and rails can be set to display in plan view in the Railing Specification dialog. See [Newels/Balusters Panel on page 409](#).

It is sometimes helpful to display the walls from a floor other than the current floor. To do this, select and display a reference floor. See [The Reference Display on page 738](#). You can also specify which layers are included in the Reference Display Layer Set in the Layer Display Options dialog.

## NOTIFICATION ICONS

Occasionally, the program may detect a problem with one or more walls in a plan. When this is the case, notification icons will display on the floor where the problem has occurred:

- If a wall is drawn at an off angle, the **Off Angle Wall**  icon will follow the mouse pointer and a Caution  symbol will display over the problem wall in plan view.
- If there is a problem with a wall connection, the **Connect Walls**  icon will follow the mouse pointer and a Caution  symbol will display at the problem location.

The recommended response to either situation is to fix the problem, although you can choose to ignore it if you prefer. See [Wall Angles on page 358](#) and [Fix Wall Connections on page 362](#).

If an issue has been ignored, notification icons for it will not display. Select **Tools> Checks> Reset Notification Icons** to display any suppressed notifications so that any wall angle or connection problems can be corrected.

## IN 3D VIEWS

As in plan view, the display of walls can be controlled by layer in the Layer Display Options dialog.

Each layer of a wall is generated when you create a 3D view. You can see the different layers in 3D using the **Delete Surface**  tool. See [Delete 3D Surface on page 1099](#).

A wall's framing layer displays as a solid layer rather than studs and plates until wall framing is built. See [Framing on page 850](#). Wall framing is placed on the "Framing, Wall" layer by default.

When a camera is located on the exterior of a structure, you can select **3D> Camera View Options> Hide Camera-Facing Exterior Walls** , allowing the interior to be seen as you rotate around the model. Interior walls set as Attic walls are also hidden when this setting is active. See [Hide Camera-Facing Exterior Walls on page 1135](#).

While most architectural objects in the program can display in both floor plan and 3D views, a few cannot. Invisible walls and Wall Hatching are examples of objects that do not display in 3D, regardless of what layer they are placed on.

Unlike in plan view, doors and windows placed in a wall can display in 3D views even if the wall's layer is turned off. See [3D View Defaults Dialog on page 1083](#).

## IN CROSS SECTIONS

When the **Auto Detail**  tool is used in a cross section view, the fill style of each wall layer as set in its Wall Type Definition is used. See [Detailing Cross Section/Elevation Views on page 1094](#).

## WALL LABELS

Wall labels are located on the "Walls, Layers" layer and can be set to display in plan and cross section/elevation views. See [Label Panel on page 700](#).

Walls do not have Automatic Labels by default. Once wall framing has been built, however, framed walls will be assigned Automatic Labels that correspond to each wall's **Wall Detail** . See [In Wall Detail Views on page 880](#).

Concrete and masonry walls' automatic labels are always blank; however, custom labels can be assigned to any wall in the Wall Specification and Defaults dialogs. If you wish, you can use Named Values to create custom text macros for wall labels. See [Working with Name-Value Pairs on page 1389](#).

Wall label information included when **Export to REScheck**  is used. See *Export to REScheck on page 1240*.

## WALL MATERIALS

There are several ways that materials can be assigned to walls, depending on how the walls and the rooms they define have been defined. See *Rooms on page 412*.

When you draw a wall, it uses the materials specified in its wall type definition. See *Wall Type Definitions on page 384*.

You can change the surface material of an individual wall in the Wall Specification dialog. If you select “Use Default” as the material and the wall is used to define a room, the program refers to the material specified in the Room Specification dialog. See *Wall Specification Dialog on page 392*.

You can also change a room’s wall material in the Room Specification dialog. See *Materials Panel on page 1055*. To restore the default Wall Type material, select **Use Default** in the Select Material dialog. See *Select Material/Library Object Dialog on page 1056*.

Wall materials can also be changed using the **Material Painter**  tool, but bear in mind that depending on which Material Painter Scoping Mode is in use, only a portion of the wall may be painted and that the entire room may be affected rather than the individual wall. See *Material Painter and Walls on page 1054*.

When neither the wall nor the room has a material assigned to it, the program refers to the general material for walls in the Material Defaults dialog. See *Material Defaults on page 1051*.

Note: Wall materials that are specified on the Materials panel of either the Wall or Room Specification dialog are not calculated in the Materials List.

## IN THE MATERIALS LIST

The materials that make up wall assemblies are listed under different Categories in the Materials List:

- **Siding** - Lists the materials assigned to each wall’s Exterior Layers, such as siding, sheathing, and housewrap.
- **Framing** - Lists the framing material(s) for all walls as well as railings specified as Solid. Non-framed walls’ Main Layer materials are also listed here when those walls are not specified as Foundation. Wall framing, including studs, plates, and headers, is only counted when a framing material has been assigned to a wall type and wall framing has been built. See *Framing on page 850*.
- **Insulation** - Insulation is calculated for all walls that separate Conditioned from Unconditioned space, are not defined as Railings, and have one or more Framing layers. Insulation thickness is equal to that of the framing layer. See *Exterior and Interior Walls on page 351*.
- **Wallboard** - Lists the materials assigned to each wall's Interior Layers, such as drywall.

Does not include Wall Coverings or materials specified in either the Room or Wall Specification dialog. See *Materials Panel on page 405*.

- **Interior Trim** - Lists base, crown and chair rail moldings, and Wall Covering materials specified in the Wall and Room Specification dialogs. See *Wall Covering Panel on page 404*.
- **Foundation** - Lists the concrete, block, and rebar for all walls specified as Foundation as well as their footings. See *Foundation Walls on page 352*.
- **General** - Reports the thickness of glass wall materials and their total lengths.

With the exception of wallboard, windows and doors are taken into account in the calculation of these totals.

Slab Footings as well as the room areas that they define can be assigned **Pour Numbers** in their specification dialogs. Pour Numbers are listed separately under the Foundation category of the Materials List. See [Foundation Panel on page 400](#).

Wall framing members can be reported in a Materials List using one of four methods: Linear Length, Buy List, Cut List, or Mixed Reporting. See [Structural Member Reporting on page 1306](#).

## WALL SCHEDULES



The **Wall Schedule** tool allows you to produce customizable wall schedules or legends with information about wall types, wall assembly layers, length, and more. See [The Schedule Tools on page 682](#).

All wall types present in the current plan are listed in the Schedule Specification dialog. See [Wall Type Definitions on page 384](#).

When a new wall type is created, it will be included in any existing Wall Schedules as well as in the Wall Schedule Defaults automatically. See [General Panel on page 692](#).

A wall type that is not set to be included may still be listed in a Wall Schedule if it is part of a Pony Wall. See [Pony Walls on page 354](#).

You can also specify which individual walls are included in a Wall Schedule in the Wall Specification dialog. This affects totals like "Total Length" and "Count". If the wall in question is the only instance of its wall type, that wall type will not be listed even if it is set to be included in the Wall Schedule. See [General Panel on page 392](#).

An Invisible Wall will be included in a Wall Schedule provided that its wall type is set to be included and it has **Include in Schedule** checked.

---

## Measuring Walls

Accurate wall measurements are an essential aspect of any drawing, and can be achieved by following two basic rules:

- Be aware of what part of a wall assembly dimensions are locating;
- Position walls using dimensions rather than edit handles or edit tools.

These rules can easily be met when you keep the following recommendations in mind.

For information about changing the value reported in a dimension line label, see [Using Dimensions on page 369](#).

### DIMENSION DEFAULTS

Manually-drawn, automatic, and temporary dimensions can all be set to locate walls at their Dimension Layers or at their surfaces. Before drawing dimensions - and particularly, before using them to move your walls into position - make sure that all of your Dimension Defaults are set up to meet your needs. See [Dimension Preferences and Defaults on page 449](#).

If a wall is specified as Invisible, dimensions will locate it at its centerline regardless of its Wall Type Definition or your Dimension Defaults settings. If the Invisible wall divides rooms with different floor heights, dimensions will locate the edge of the wall facing the room where the floor is lower.

Be aware, too, that the wall length dimension that displays when a wall is selected as well as the **Length** specification in the Wall Specification dialog do not inherit their settings from the Dimension Defaults. Instead, they follow the **Resize About** line. See [Resize About on page 375](#).

Manually-drawn and automatic dimensions can also be set to locate a number of elevation marks associated with walls. See [Locate Elevations Panel on page 466](#).

## PRIMARY AND SECONDARY SIDES

When dimensions that locate walls are drawn or generated in plan view, a Primary and a Secondary Side for each wall is identified. For exterior walls, the Primary Side is always the exterior side of the Wall Type Definition and the Secondary side is always the interior. See *Wall Type Definitions on page 384*.

For interior walls, the functionality is more complex:

- For vertical interior walls with perfectly symmetrical wall layers, the Primary Side is always on the left side of the wall as it is drawn in the plan, regardless of the orientation of its layers.
- For horizontal interior walls with perfectly symmetrical wall layers, the Primary side is always on the bottom side of the wall as it is drawn in the plan.
- For both vertical and horizontal interior walls with wall layer that are not symmetrical, the functionality is the same as that for exterior walls: the Primary Side is always the exterior side of the Wall Type Definition and the Secondary side is always the interior.

With the exception of Interior and Auto Room Dimensions, you can specify whether the various dimension tools locate the Primary Side, Secondary Side, or both in the Dimension Defaults dialog. See *Locate Manual Panel on page 454*.

## EDIT DIMENSION LINES

Once a dimension line has been drawn, its extension lines can be edited to locate a number of locations on a wall assembly:

- The exterior surface
- The Wall Dimension Layer's exterior
- The center line of the wall assembly
- The Main Layer's center line
- The Main Layer's interior
- The interior surface

Dimension lines that are drawn through a wall can also be set to measure and report the widths of walls, or to suppress that information. See *Dimension Panel on page 486*.

See *Editing Extension Lines on page 478*.

## MOVING WALLS USING DIMENSIONS

By far, the most precise method of positioning walls is using dimension lines. To produce accurate measurements, remember to:

- Be aware of what part of your walls is being located by each type of dimension.
- Avoid specifying dimension values with greater accuracy than your dimensions are set to display. See *Primary Format Panel on page 459*.

See *Using Dimensions on page 369*.

Remember that the temporary wall length dimension that displays when a wall is selected may be set to locate a different part of the wall assembly than other dimension lines. See *Wall Length on page 371*.

## USE OBJECT, ANGLE AND GRID SNAPS

Object Snaps, Angle Snaps, and Grid Snaps make it easier to align walls when they are being drawn as well as when they are edited. See *Snap Behaviors on page 159*.

**Object Snaps**  help to ensure consistent wall connections and are particularly helpful when aligning collinear walls.

When **Grid Snaps**  are enabled, walls are drawn on a regularly spaced grid, which helps avoid inaccurate wall placement. This can become particularly important if you forego positioning walls using dimensions in favor of using edit handles to move them.

 Using Grid Snaps is recommended when you are laying out exterior shell walls, but may be inconvenient when positioning interior walls or other objects.

**Angle Snaps**  make it easy to accurately draw walls at regular angles, ensuring walls that are truly parallel or perpendicular to one another and separated by consistent distances.

## NO LOCATE

If a wall is specified as **No Locate** in the Wall Specification dialog, it will be ignored by **Auto Exterior Dimensions**  in plan view, as will any doors or windows placed in it. See [Dimensions on page 448](#).

By default, **Railings**, **Deck Railings**, and **Room Dividers** are specified as No Locate. See [General Panel on page 392](#).

If a wall is on its default layer and is specified as **No Locate**, it will be moved to the “Walls, No Locate” layer. If this box is later unchecked, the wall will return to its default layer. If a wall is on a non-default layer, it will remain there. See [Displaying Walls on page 363](#).

Once a dimension line has been created, it can be edited so that it locates a No Locate wall or railing that is perpendicular to it. See [Editing Dimension Lines on page 476](#).



## Editing Walls

Walls can be selected in all views. When a wall is selected, it displays edit handles and an edit toolbar that can be used to modify it in various ways. When a wall is selected, temporary dimensions may also display. See [Temporary Dimensions on page 473](#).

The ways in which a wall can be edited depend on the current view and which edge is selected. See [Selecting Objects on page 210](#).

### SELECTING WALLS



Like other objects, walls can be selected in a variety of ways. See [Selecting Objects on page 210](#).

In plan view, if wall hatching has been applied to a wall using the **Wall Hatching**  tool, it is possible that the hatching may be selected first. If it is, click **Select Next Object**  to select the wall itself. See [Wall Hatching on page 357](#).

- When **Select Room Before Wall in 3D** is checked in the Preferences dialog and you click on a wall in a cross section/elevation or camera view, the room defined by that side of the wall will become selected instead of the wall. See [Appearance Panel on page 95](#) and [Selecting Rooms on page 418](#).

When this is the case, you can select the wall by clicking the **Select Next Object**  edit button or pressing the Tab key.



- In plan views, the **Edit Area**  tools allow you to select only part of a wall or walls. See *Edit Area Tools on page 269*.
- In a Wall Detail, Framing Overview or other 3D view in which wall framing can be seen, select a wall framing member and click the **Find Wall**  edit button to switch to a plan view in which the wall associated with the selected framing is selected. A wall selected in this manner can then be edited even when its layer is turned off and/or locked. See *Locking Layers on page 178*.

## USING THE EDIT HANDLES

A selected wall can be modified in a variety of ways using its edit handles in any view. The handles that are available will depend on the current view type. See *Edit Handles for Walls on page 372*.



## IN THE SPECIFICATION DIALOG

 The appearance and structure of walls can be customized in the Wall Specification dialog. See *Wall Specification Dialog on page 392*.

The characteristics of the roof directly above a selected wall can also be specified in the Wall Specification dialog. See *Roof Panel on page 398*.



## USING THE EDIT TOOLS

A selected wall or walls can be edited in a variety of ways using the buttons on the Edit Toolbar. See *The Edit Toolbar on page 130*.

When a wall has been customized to meet your needs, you can apply its attributes to other walls using either the **Object Eyedropper**  tool or the **Match Properties**  edit tool. See *Matching Properties on page 282*.

## REVERSE LAYERS

 When walls enclose an area to form a room, the program will orient all exterior walls so that the siding material faces outward. When needed, you can click the **Reverse Layers** edit button to flip the orientation of the interior and exterior layers of a selected wall. Its wall type definition is not affected by this change. See *Interior and Exterior Surfaces on page 386*.

When a wall has **Lower Wall Type if Split By Butting Roof** checked in its specification dialog and its interior wall layers are oriented to face adjacent roof planes, a Caution  symbol will display at the problem location in plan view and the Reverse Layers  icon will follow your mouse pointer. See *Roof Panel on page 398*.

Click on the Caution  symbol that displays over the wall to open a contextual menu:







- Select **Reverse Layers** to flip the wall's interior and exterior layers.
- Select **Ignore Reversed Wall** to leave the wall unchanged and suppress the Caution symbol.

## USING DIMENSIONS

 Automatic, manually-drawn, and temporary dimension lines can be used to both resize and move walls with accuracy.

- Select a wall, then click on a dimension line that locates it and type in the value that you need. See *Moving Objects Using Dimensions on page 483*.

When a wall is resized using dimensions, the inline text field used to edit the dimension will have three unique buttons:

- Horizontal walls have **Move Left End** , **Move Both Ends** , and **Move Right End** .
- Vertical walls have **Move Top End** , **Move Both Ends** , and **Move Bottom End** .

Note: If only one of these buttons is available, the wall end that the button references is the only part of the selected wall that the dimension line actually locates, and only that end can be moved using the selected dimension.

Choose the option that you want to use before pressing the Enter key.



If both ends of the selected wall intersect walls that are not parallel to one another, a fourth option will be available: **Move Along Rails** . When this option is used, the selected wall both resizes and changes position so that it remains connected to the other walls when you press the Enter key.

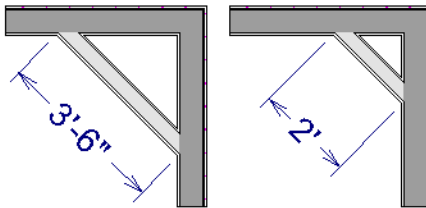

Depending on your Dimension Defaults settings, manual, automatic, and/or temporary dimension lines may locate wall surfaces or wall dimension lines. See [Locate Manual Panel on page 454](#).

Dimensions can be set to locate **Wall Steps** in elevation views. Steps in foundation walls in plan views can also be located. Wall steps cannot be moved using dimensions, however. See [Stepped Walls and Footings on page 381](#).

Dimension lines do not locate foundation wall footings when they are first drawn. Their extension lines can be edited to do so, however. See [Editing Extension Lines on page 478](#).

Unlike other types of walls, the thickness of a **Slab Footing**  can be resized using dimensions. A new wall type may result. See [Editing Foundations on page 713](#).

Bear in mind that temporary dimensions can be set up to locate different wall layers than automatic and manual dimensions. As a result, they may appear to give different measurements between the same walls. See [Temporary Dimension Defaults Dialog on page 467](#).

Only the portions of pony walls that display are located by dimensions. The upper and lower parts of pony walls typically have different thicknesses, so which part you choose to display may affect your plan's dimensions. See [Pony Wall Defaults on page 345](#).

 Dimension Defaults and Temporary Dimension Defaults can have a significant effect on wall position. It is recommended that you review these settings and make sure that they meet your needs.

## WALL THICKNESS

The initial thickness of a wall is determined by its wall type definition. You can change a wall's thickness by modifying its wall type. If you do this, all instances of the wall type used in the plan will be affected - not just an individual object. See [Wall Type Definitions on page 384](#).

You can also specify a selected wall's thickness in its Wall Specification dialog. See [General Panel on page 392](#).

If a selected wall's thickness is changed:

- A copy of the wall's wall type is created with the same name but appended with a number equal to the thickness of the Main Layers, and that new type is assigned to the wall. See *The Main Layer on page 385*.
- The change in thickness will be applied to new wall type's innermost Main Layer.
- The Main Layer must be at least 1/16" thick, and the wall's thickness cannot be less than the original wall type's total thickness minus the thickness of its Main Layer.

If a wall type's thickness is modified, the wall will resize about the **Resize About** line specified in the General Wall Defaults dialog. In some instances, the wall may appear to move as a result of changes made to the thicknesses of its layers. See *General Wall Defaults on page 343*.

## WALL HEIGHTS

The height of a wall is controlled by the ceiling height of the room(s) it defines. If the ceiling or floor height of a room is changed, the height of the walls that define it also change.

- The initial ceiling height for all rooms on a floor is set in the Floor Defaults dialog for that floor. See *Floor Level Defaults on page 413*. Whenever possible, it is best to set all ceiling heights using the default.
- The ceiling height of a single room can be set in its Room Specification dialog. See *General Panel on page 438*.
- The default Floor and Ceiling Heights for a given floor can be adjusted by editing the top and/or bottom edges of the Exterior Room in a 3D view. See *The Exterior Room on page 418*.
- The top or bottom edge of any wall can be adjusted independent of floor or ceiling heights using the mouse in Cross Section/Elevation and 3D views. Top and bottom edges can also be stepped and raked. See *Stepped and Raked Walls on page 381*.
- The top height of a selected Railing can also be edited in Cross Section/Elevation and 3D views. The bottom height, however, cannot. See *Railing and Deck Tools on page 349*.
- The edge dividing an upper and lower pony wall can be edited in Cross Section/Elevation and 3D views. In addition, its height can be defined in the Wall Specification dialog. See *Wall Types Panel on page 402*.

## WALL LENGTH

Wall length can be modified in several different ways:

- Using dimensions. See *Measuring Walls on page 366*.
- In the Wall Specification dialog. See *General Panel on page 392*.
- Using the **Add Break**  edit tool to divide a selected wall into two segments. See *Add Break on page 254*.
- By dragging the end edit handles. See *Editing Line-Based Objects on page 216* and *Editing Arc-Based Objects on page 219*.

Bear in mind that if you try to resize a wall by a small amount using one of its edit handles and that wall is connected to another wall at that end, its length will not change because its end will snap back to the existing intersection. See *Connecting Walls on page 361*.

The most accurate way to specify wall length is using dimensions. By default, wall length is measured at the outside edge of the Main Layer. You can instead specify that manual, automatic, and/or temporary dimension lines locate surfaces in the Dimension Defaults dialogs. See *Dimension Preferences and Defaults on page 449*.

Be aware that the wall length dimension that displays when a wall is selected as well as the **Length** specification in the Wall Specification dialog do not inherit their settings from the Dimension Defaults. Instead, they follow the **Resize About** line. See *Resize About on page 375*.

Note: By default, dimensions and the Resize About line all use the exterior edge of the Main Layer. When Resize About is set to use a different location, dimension lines may not agree with a wall's length specification. See [Measuring Walls on page 366](#).

## LOCKED VS. UNLOCKED CENTERS

The default for curved walls is an unlocked center because it is easier to draw and edit when the center is unlocked.

Once walls are in place and curved walls are properly aligned with straight walls, it is a good idea to lock the curved walls' centers.

To lock the center of a curved wall, select it and click the **Lock Center**  edit button. See [Lock Center on page 223](#). The curved wall remains selected, but its edit handles change.

The locked status can also be changed in the GENERAL panel of the Wall Specification dialog. See [General Panel on page 392](#).

---

## Edit Handles for Walls

Walls can be edited extensively using their edit handles. Depending on the type of view, a wall displays a different set of edit handles when selected.

Moving a wall in any view will move any cabinets attached to that wall, as well.

### IN PLAN VIEW

In plan view, straight and curved walls and their footings can be edited like other line- and arc-based objects. See [Editing Line-Based Objects on page 216](#) and [Editing Arc-Based Objects on page 219](#).

In addition:

- A wall's edit handles display along its **Resize About** line. See [Resize About on page 375](#).
- A wall can only be moved perpendicular to itself or, in the case of curved walls, perpendicular to its chord using the Move edit handle. To move a wall at Allowed Angles, use the **Alternate**  Edit Behavior. See [Alternate on page 207](#).
- When wall labels are set to display and a wall has a label, it will have a small, square Move edit handle and a small rectangular Rotate edit handle.

### IN CAMERA VIEWS

The edit handles that are available for a selected wall in a camera view depends whether the wall is selected on its interior or exterior surface or on its top or bottom edge.

- In a cross section/elevation view, the top and bottom edges of straight and curved walls can be edited like closed polylines. See [Editing Closed Polyline-Based Objects on page 228](#). Only the top and bottom edges of walls can be broken, angled, or curved: the side edges cannot.
- In a camera view or overview, click on an interior or exterior surface to display the same edit handles as in an elevation view: one at each corner and one on the top and bottom edges.

- In a camera view or overview, click on the top surface of a wall to display the same edit handles as in plan view, allowing you to rotate, move, and extend or shorten the length of the wall.
- The footings of Foundation Walls and Slab Footings can be selected in 3D views and edited using the edit handles. See *Footing Width and Height on page 714*.

### SAME WALL TYPE EDIT HANDLES

 The **Same Wall Type** edit handles allow you to draw a new wall extending out from either end of a selected wall and with identical properties as that wall. These edit handles are enabled globally in the Preferences dialog. If you prefer, you can disable them globally and enable them only as needed by selecting a wall and clicking the **Same Wall Type** edit button. See *Architectural Panel on page 113*.

When the Same Wall Type edit handles are enabled, two edit handles display just beyond a selected wall's Extend edit handles in plan view or when the top edge of the wall is selected in a 3D view.

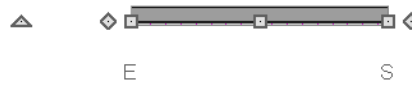

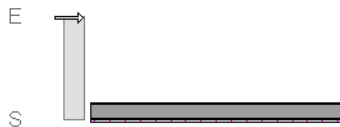

Click and drag a Same Wall Type edit handle at any angle to draw a new wall segment of the same type as the selected wall.



### WALL LAYER INTERSECTIONS EDIT HANDLES

 The **Edit Wall Layer Intersections** edit tool lets you control how a wall's layers build into another intersecting wall. When you click this edit button, the selected wall's standard set of edit handles are replaced by a set of Wall Layer Intersection handles which you can use to modify the length of each wall layer. See *Connecting Walls on page 361*.

#### *To edit wall layer intersections*

1. Select a wall and click the **Edit Wall Layer Intersections**  edit button.
  - This edit button is not available if the wall is not connected to another wall at either end.
2. **Zoom**  in on either end of the wall so its edit handles can be clearly seen.
  - A Wall Layer Intersection edit handle is located at the midpoint of each wall layer.
3. Click and drag a Wall Layer Intersection handle either towards or away from the opposite edge of the intersecting wall.
  - As you drag, the wall layer will snap to the wall layer lines of the intersecting wall.
4. When you are finished, click the **Main Edit Mode**  edit button or press the Esc key.

## Editing Straight/Curved Wall Combinations

If you move a straight wall connected to a curved wall with a locked center and the connection cannot be maintained without changing the center of the arc, the walls lose their connection.

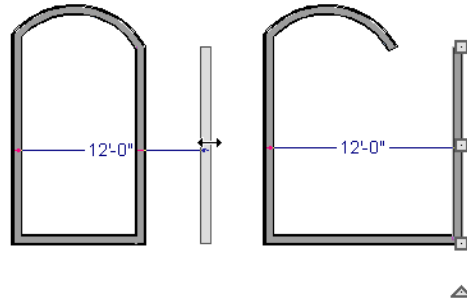

When an Extend edit handle of a curved wall with a locked center is dragged with the **Alternate** **Alt** Edit Behavior active, the locked center setting will be overridden. See *Defaults, Preferences, and Edit Behaviors on page 206*.

If you move a straight wall connected to a curved wall with a locked center, the curved wall extends along its curve and the straight wall will either lengthen or shorten as needed to stay connected to the curved wall.

If the connection between the straight and curved wall cannot be maintained because of the curved wall's radius, it will be broken.

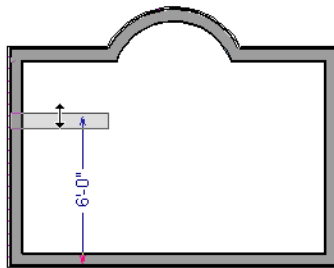

### MAKE ARC TANGENT

If both ends of a selected curved wall are connected to other walls at angles of 45° or less, the **Make Arc Tangent** edit button is available. Click this button to open the Radius of Tangent Curved Wall dialog.

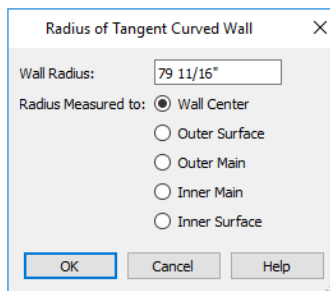

- Specify the **Wall Radius**, which is measured from the curved wall's Arc Center to the **Measured to** location, specified below.

- Specify where along the curved wall's thickness the radius should be **Measured to**. The wall's radius is usually changed by this action and a locked center automatically becomes unlocked. See [Wall Type Definitions on page 384](#).

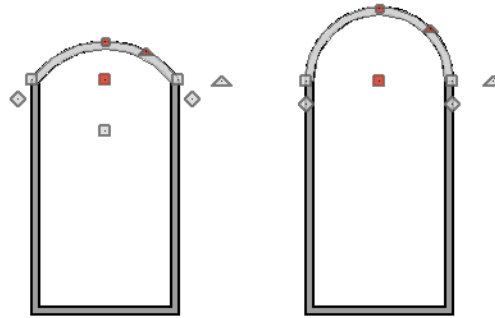

When you click OK, the curved wall will adjust its length and position so that its ends become tangent to the walls it is attached to.

---

## Aligning Walls

Wall alignment refers to the way wall segments line up with one another, either on the same floor or on the floor above or below. Walls may need to be aligned in a variety of situations.

To make alignment easier when drawing or resizing walls, “sticky” points and extension lines identify points that are either collinear or orthogonal to the end points of other walls. See [Extension Snaps on page 161](#).

### RESIZE ABOUT

The **Resize About** line specified in the General Wall Defaults dialog controls two important aspects of wall alignment:

- What part of a wall retains its position when its wall type or wall type definition is changed. See [Wall Type Definitions on page 384](#).
- Where walls snap together to form an intersection. See [Connecting Walls on page 361](#).

See [General Wall Defaults on page 343](#).

The **Resize About** line is the line along which a selected wall's length is measured in the Wall Specification dialog. See [Wall Length on page 371](#).

The **Resize About** line is also the line along which a selected wall's edit handles display, and is the line along which any snap points will be located. See [Editing Walls on page 368](#).

### ALIGNING COLLINEAR WALLS

Collinear walls are parallel walls connected end to end and drawn on the same floor. When collinear walls join end-to-end, the walls snap together. If these walls have the same wall type and identical specifications, and if **Object Snaps**  are enabled, they will merge to become a single wall segment.

### CREATING A NOOK

Walls can be aligned across an opening such as a nook, so that they are collinear, using the **Add Break**  edit tool.

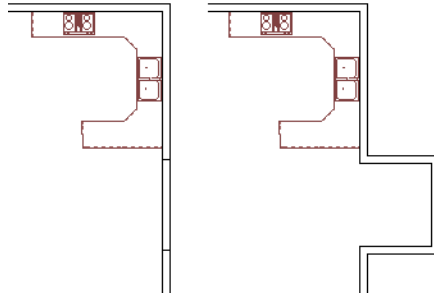

### ***To align walls across a gap***

1. Select a wall to build a nook into and click the **Add Break**  edit button.
2. Click at a point on the wall close to one side of the nook area. Do not worry about exact placement right now.
3. Click again near the other side of the nook. Two short lines at each location where you clicked indicate Breaks in the walls.



4. Right-click the middle section of the wall to select the wall section.
5. Click the middle Move handle and drag the wall outward.
6. Draw side walls to connect the wall back to the rest of the house.
7. Move these short walls using dimensions to accurately size the nook.



### **ALIGNING WALLS BETWEEN FLOORS**

  Walls can be aligned between floors by clicking the **Align With Wall Above** and **Align With Wall Below** edit buttons.



By default, walls on different floors are aligned by the outer edges of their Main Layers. See [The Main Layer on page 385](#).

 In order for these edit tools to be available, the areas of the walls in question must be partially aligned, or overlapping.

### ***To align walls between floors***

1. Select a wall that you want to align with another wall either above or below it.
2. If the wall is above or below the other wall along only part of its length, you must click on it along that part. Select **Tools> Floor/Reference Display> Reference Display On**  to help make sure you click on the correct part of the wall.
3. When you have selected the wall at the desired location, click either the **Align With Wall Above**  or **Align With Wall Below**  edit button.

### **ALIGNING CURVED WALLS BETWEEN FLOORS**

Curved walls are aligned between floors using the same technique to align straight walls. If the centers and radii of the walls are within a few inches of each other, the **Align With Wall Above**  and **Align With Wall Below**  edit buttons are enabled for the selected wall. The selected curved wall will take on the radius and center of the referenced wall when the walls are aligned.



## ALIGNING PONY WALLS BETWEEN FLOORS

When aligning a pony wall with either the wall above or below:



**Align With Wall Below** will always align the lower pony wall with the wall below, as specified in the lower pony wall's Wall Type Definition. See [Wall Type Definitions on page 384](#).



**Align With Wall Above** will always align the upper pony wall with the wall above, as specified in the upper pony wall's Wall Type Definition.

## ALIGNING FOUNDATION WALLS

By default, foundation walls and slab footings will align with walls on the floor above along the outside surface of the Main Layer of both wall types. If you prefer, you can specify that foundation walls align to a different part of the walls above. The **Foundation To This Line** setting in the Wall Type Definitions dialog controls how a wall of a given type aligns with foundation walls directly below on Floor 0. See [Wall Type Definitions on page 384](#).

By default, **Foundation To This Line** is specified for the Main Layer of most wall types. An exception to this are brick wall types, which have Foundation To This Line specified for the exterior siding layer. See [Brick Ledges on page 353](#).

If there is only one layer for both the stem wall and the first floor wall above it, the exterior surfaces of the walls align. The footing is centered on the stem wall unless this option is unchecked in the Wall Specification dialog. See [Foundation Panel on page 400](#).

## ALIGNING CURVED WALLS WITH STRAIGHT WALLS



Curved walls can be drawn tangent to an existing straight wall using the **Start/Tangent/End Arc Mode**. See [Drawing Arcs - Arc Creation Modes on page 307](#).





If both ends of a selected curved wall are connected to other walls, the **Make Arc Tangent** edit button is available. Click this button to move and resize the wall so that both ends are tangent to the connected walls. See [Make Arc Tangent on page 374](#).

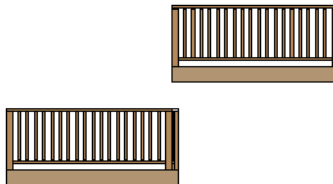

## ALIGNING RAILINGS ON DIFFERENT PLATFORMS

Two collinear Railings or Deck Railings on the same floor can be aligned one above the other when they define rooms with different floor heights.



### *To align railing on different platforms*

1. Click and drag to draw a Railing or Deck Railing that divides a room such as a deck in two.
2. Click the **Select Objects**  button, then click in one of the room areas.
3. Click the **Open Object**  edit button, and on the GENERAL panel of the Room Specification dialog:

- Specify a **Floor Height** that differs from that of the other by at least the height of the railing, then click OK.
  - The default railing height is 36", so for best results the Floor Height should be changed by at least this amount.
4. Click on the railing drawn in step 1, then click the **Open Object**  edit button. On the RAIL STYLE panel of the Railing or Deck Railing Specification dialog, check **Generate on Low Platform**. See *Rail Style Panel on page 407*.
  5. Click and drag a second railing parallel to the one drawn in step 1.
  6. Select this second railing and click the **Open Object**  edit button. On the GENERAL panel of the Railing or Deck Railing Specification dialog, check the box beside **No Room Def** and click OK.
  7. With the railing still selected, Ctrl + drag it into the same position as the first railing. See *To move an object freely on page 244*.



---

## Roof Directives in Walls

To automatically generate a roof plane using values other than the defaults or to not generate a roof plane bearing on a particular wall (as for a gable or the sides of a shed roof), you can change the settings in the Wall Specification dialog. See *Roof Panel on page 398*.

### HIP, GABLE, AND SHED ROOFS

By default, the program will produce a roof plane over each exterior wall to create a hip roof. You can specify a different condition over a selected wall, however. For example:

- Check **Full Gable Wall** to create a gable with a ridge centered above the selected wall(s).
- Check **High Shed/Gable Wall** for the side walls or the wall under the high side of a shed roof.
- You can also select a wall and click the **Change to Gable Wall(s)**  edit button, or change it back by clicking the **Change to Hip Wall(s)**  edit button.

### PITCH

The default pitch for roof planes is set in the Build Roof dialog. However, any exterior wall can define the pitch of the roof plane built above it.

You can also specify a second, upper pitch above a given wall. Mansard, gambrel, gull wing and half-hip are examples of roof styles that use two pitches.

### OVERHANGS AND ROOF RETURNS

You can specify the overhang of the roof plane to be generated above the selected wall. This setting only takes effect when Same Height at Exterior Walls is unchecked in the Build Roof dialog, which is also where the default Overhang value is set.

Check **Auto Roof Return** to generate roof returns on the selected wall. In most cases, roof returns only generate on Full Gable Walls. See *Roof Returns on page 844*.

### EXTEND SLOPE DOWNWARD

Check **Extend Slope Downward** to extend the roof plane downward over a bump-out, instead of creating additional roof planes. The two connecting walls that create the bump-out must be Full Gable walls.

In the following image, the bearing wall of the bump-out has **Extend Slope Downward** checked. The two short side walls are **Full Gable Walls**.

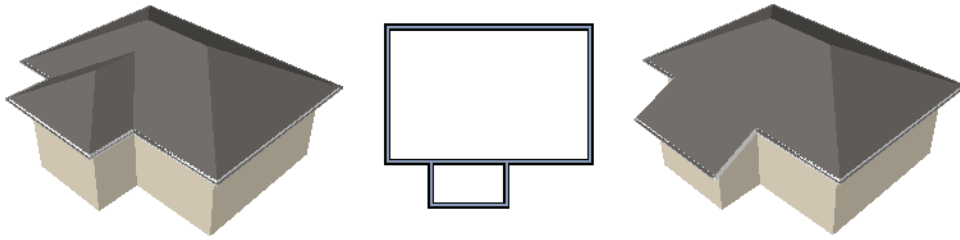

### CLERESTORY AND DORMER WALLS

Occasionally, walls are built between two roof planes rather than between a roof plane and a floor platform. Common examples include clerestory walls and the side, or the cheek, walls of floating dormers.

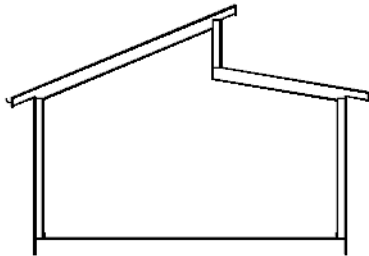

Check **Roof Cuts Wall at Bottom** to have the bottom of the selected wall clipped by the roof plane below, as where a floating dormer wall meets the main roof plane.

### EXTERIOR/INTERIOR PONY WALLS

It's not uncommon for an individual wall to be an exterior wall near its top, and an interior wall near its bottom.

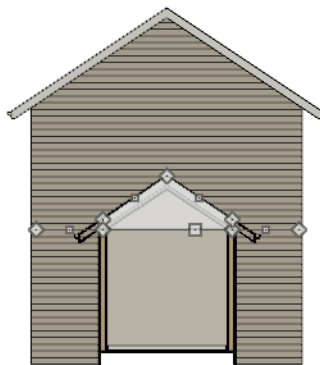

Check **Lower Wall Type If Split By Butting Roof** to achieve this. When this option is checked, the selected wall is specified as a pony wall and a second, lower wall type can be specified. Unlike with other pony walls, the change in wall type occurs wherever a roof plane builds to the exterior of the wall. See [Pony Walls on page 354](#).

## Attic Walls

In Chief Architect, walls are built between the floor and ceiling platforms of the current floor. See *Floor and Ceiling Heights on page 426*. When the program detects an open space between a wall and the roof plane above it, it automatically creates an Attic Wall on the floor above that wall to fill in the gap.

Attic Walls are typically found above Full Gable Walls, forming a gable or closing the top portion of a side wall of a shed roof. They are also generated above all exterior walls when the **Raise Off Plate** value in the Build Roof dialog is 3" (175 mm) or greater. See *Build Roof Dialog on page 797*.



Attic Walls are often found on the Attic floor, but can be generated on other floors, as well. See *The Attic Floor on page 738*.

Attic Walls are specified as such in the Wall Specification dialog; if automatically generated, that will be noted as well. If needed, you can specify a regular wall as an Attic Wall. If you specify a wall as an Attic Wall and it is currently on its default layer, it will be moved to the "Walls, Attic" layer, See *General Panel on page 392*.

When you **Rebuild Walls/Floors/Ceilings** , all automatically generated Attic Walls in the plan are deleted and rebuilt unless **Auto Rebuild Attic Walls** is also checked in the General Wall Defaults dialog. See *General Wall Defaults on page 343*.

### REMOVING ATTIC WALLS

Occasionally, the program will generate an Attic Wall where one is not wanted. There are several ways to address this:

- Turn off the display of the layer that the Attic Wall is on.
- Specify the Attic Wall as **Invisible**. See *Room Dividers and Invisible Walls on page 355*.
- Some interior Attic Walls can be suppressed by specifying space they enclose as a **Shelf Ceiling**. See *Shelf Ceilings on page 428*.
- Select the Attic Wall and **Delete**  it. When **Auto Rebuild Attic Walls** is on, the program will specify the wall as Invisible automatically. If you delete this Invisible wall, a new Attic Wall will be created.
- Turn off **Auto Rebuild Attic Walls** in the General Wall Defaults dialog and then **Delete**  the wall.
- Combine the Attic Wall with the wall below. To do this, select **Combine with Above Wall** in the Wall Specification dialog for the wall below. See *Roof Panel on page 398*.



### KNEE WALLS

Knee Walls are a bit like Attic Walls in that they are not meant to generate to full ceiling height. Instead, they build upward until they encounter a roof plane. Unlike Attic Walls, however, Knee Walls are used in the interior of a structure, typically to separate unused areas from rooms on the upper floor of a story-and-a-half structure. See *Room Types and Functions on page 415*.

Chief Architect does not specify walls as Knee Walls automatically. If an interior wall is drawn in a location where the roof is lower than the ceiling height, you should specify it as a Knee Wall in the Wall Specification dialog. See *Roof Panel on page 398*.

For best results, Knee Walls should be drawn perpendicular to the pitch of the roof and should intersect with Full Gable Walls on each end.

## Stepped and Raked Walls

Stepped and raked walls can be created using the **Add Break**  edit tool and the wall's edit handles in any 3D or cross section/elevation view. In many cases, working in a **Back Clipped Cross Section**  is easiest and allows the greatest accuracy.





When you try to select a wall in a 3D view, the interior or exterior room that it defines may be selected first. Click the Select Next Object edit button to select the wall itself. See [Selecting Walls on page 368](#).

### STEPPED WALLS AND FOOTINGS

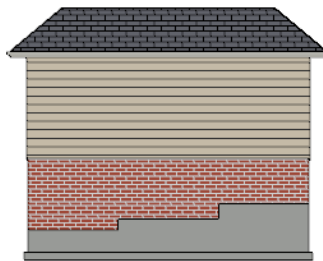
A typical example of stepped walls is a stepped foundation with pony walls. In the illustration below, the lower part of the pony wall is the concrete wall with footing, and the upper part of the pony wall is a framed wall with brick siding built to the first floor platform. See [Pony Walls on page 354](#).



#### *To add a step to a wall*

1. Select the wall in a **Back Clipped Cross Section**  view.
2. Click the **Add Break**  tool, then click the top or bottom edge of the wall to place the break.
3. In addition to the corner handles, two handles display along the broken edge.
4. Select one of these two handles, and drag up or down.
5. A square step is created.

The vertical edges of a wall cannot be broken, although they can be raked as well as moved side to side.

By default, a stepped foundation wall displays an “S” symbol at the location of each step in plan view. The display of this “S” is controlled in the Foundation Defaults dialog. See [Foundation Defaults on page 706](#).



Steps in walls can be located by dimensions in elevation views when **Wall Steps** is checked in the Dimension Defaults dialog. In addition, steps in foundation walls can be located in plan view. Wall steps cannot be moved using dimensions, however. See [Locate Manual Panel on page 454](#).

### RAKED WALLS

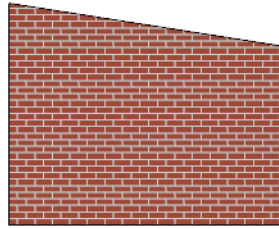
A raked wall has an angled top or bottom edge.



### ***To create a simple raked wall***

1. Select the wall in Cross Section/Elevation or 3D view.
2. Click one of the corner edit handles and drag that handle either up or down.
3. To rake a wall at a specific angle, you can:
  - Use **Angle Snaps**  and Allowed Angles. See [Angle Snaps on page 162](#).
  - Draw a **CAD Line**  at the desired angle and use the **Make Parallel/Perpendicular**  edit tool. See [Make Parallel/Perpendicular on page 250](#).

### **COMPOUND RAKED WALLS**

A compound raked wall is a wall that has a top or bottom edge with multiple angles.

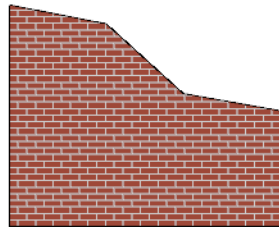

### ***To create a compound raked wall***

1. Select the wall in Cross Section/Elevation or 3D view.
2. Use the **Add Break**  tool to add breaks to the wall edge, as for a stepped wall.
3. Select a segment of the edge and adjust its angle, as for a raked wall.

---

## **Double Walls**

Most wall assemblies can be modeled using a single wall type. In some situations, such as where the walls of two modular home units meet, two walls are drawn side-by-side. When two walls are both parallel and touching, they are referred to as Double Walls.

There are three types of Double Walls in Chief Architect Premier: Frame Through, Split Framing and Furred Wall.

Note: The Double Wall options are not enabled for curved walls.

## FRAME THROUGH

**Frame Through** walls can be considered the basic Double Wall type. A Frame Through wall could be used as a double wall between hotel rooms for sound insulation.

By default, all walls are specified as **Frame Through** in the Wall Specification dialog. See *Structure Panel on page 395*.

## SPLIT FRAMING

**Split Framing** walls divide floor and ceiling platforms, as well as any walls they intersect. The split occurs at the boundary where the two double walls touch and is useful for separating modular home units.

Chief Architect Premier frames walls and platforms separately on either side of the Split Framing wall boundary, with no framing members crossing it.

You can make floor platform rim joists touch each other at the boundary between Split Framing walls or provide spacing to carry sheathing over them using the **Build Platform to Exterior of Layer** setting in the Wall Type Definitions dialog. See *Wall Type Definitions Dialog on page 387*.

To create a pair of Split Framing walls, specify both walls as such on the STRUCTURE panel of the Wall Specification dialog.

## FURRED WALLS

The recommended method for creating furring is to simply add the required air gap, framing, and finish layers to the wall type of your choice. Alternatively, though, Double Walls can be used, with the inner wall being specified as a **Furred Wall**.

**Furred Walls** are placed against the inside of a primary wall, typically an exterior wall. An example is a concrete wall furred out by a framed wall with an air gap or insulation between them.

Rooms are defined in the normal manner by the primary wall, but the layers of the Furred Wall are treated by the program as though they were added to the primary. An air gap between the primary and furred walls should be defined as a layer of one of the walls, usually the furred wall.

As with Frame Through walls, Furred Walls do not split platforms or connected walls. Unlike Frame Through walls, they do not connect or frame to non-parallel walls like normal walls. Instead, they will connect to other Furred Walls.

To create a Furred Wall, specify the primary wall as a **Frame Through** wall and the furred wall as a **Furred Wall** on the STRUCTURE panel of the Wall Specification dialog.

## OPENINGS IN DOUBLE WALLS

Doors and windows placed in one Double Wall extend through both walls. You can specify how an opening builds through the Double Walls on the CASING panel of either the Door or Window Specification dialog. See *Door Specification Dialog on page 558* or *Window Specification Dialog on page 591*.

---

## CAD to Walls



The **CAD to Walls** tool can be used to convert CAD lines in plan view into architectural objects. Two or more parallel CAD lines can be converted to both straight or curved walls or rails. CAD lines representing windows and doors can also be converted.

All lines that you want to convert to walls must be located on one layer. The same is true for windows, doors, and rails. It may be helpful to place like items on a single layer with unique layer attributes. See *Layer Display Options Dialog on page 179*.

To convert the lines of an imported drawing using **CAD to Walls** , map its layers in the Import Drawing Assistant. Do not convert lines with shared endpoints to either Boxes or Polylines. See [Select File on page 1229](#).

To convert to a specific wall type, the lines representing the wall's surfaces must be within one inch or 25mm of that wall type's width. If two wall types are specified, new walls are assigned the type having the closest width.

 For best results, delete any wall lines or polylines located between interior and exterior wall surface lines before using Convert CAD to Walls.

When CAD objects are located properly, select **CAD> CAD to Walls**  to open the Convert CAD to Walls dialog.

## CONVERT CAD TO WALLS DIALOG

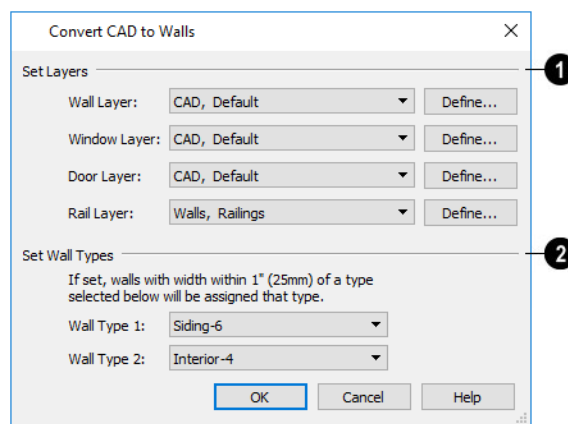

### 1 Set Layers

- From the drop-down lists, select the source layers of lines to be converted to walls, windows, doors, and rails.
- Click **Define** to open the Layer Display Options dialog.

Note: If the same layer is specified as the Wall Layer and Rail Layer, all eligible walls will be converted into railings.

### 2 Set Wall Types

Specify the wall types for the new walls.

If the distance between the surface lines is less than the total width of the specified wall type, a copy of that wall type will be created. The width of its Main Layer will adjust so that the overall width is equal to the specified wall's Main Layer.

Click **OK** to complete the conversion.

---

## Wall Type Definitions

Every wall drawn in a plan is assigned a wall type, and its Wall Type Definition determines its structure, its appearance in plan view, and its default materials. Wall types can be viewed, edited, and created in the Wall Type Definitions dialog. See [Wall Type Definitions Dialog on page 387](#).



Wall types typically have multiple layers, each representing a different material. All of these layers can be calculated in the Materials List. The materials assigned to the surface layers of the wall type definition also determine the wall's appearance in 3D views. See [Materials Lists on page 1303](#).

You can specify the default wall type that is drawn by each Wall Tool and can specify the wall type of any wall after it is drawn in the Wall Specification dialog. See [Wall, Railing, and Fencing Defaults on page 343](#) and [Wall Types Panel on page 402](#).

Wall types are plan specific, which means that wall types available in one plan file may not be available in other plans. You can, however:

- Export and import wall types. See [Exporting and Importing Wall Types on page 391](#).
- Add a wall to the library for use in other plans. See [Add to Library on page 965](#).

## THE MAIN LAYER

In most circumstances, each wall type's Main Layer should be specified as the structural layer. A wall type is considered to be:

- “Framed” if it has a Main Layer specified as **Framing**;
- “Concrete” if it has a Main Layer with the “Concrete” Material Structure Type;
- “Masonry” if it has a Main Layer with a “Masonry” Material Structure Type.

See [Materials and the Materials List on page 1063](#).

- The Main Layer determines many things in addition, including:
- Floor and ceiling platforms and automatically built foundation walls normally build to the outer edge of the Main Layer.
- The Main Layers of exterior walls build through slab floors while interior wall layers stop at the slab surface.
- At intersections, walls join at the interior surfaces of their Main Layers. See [Connecting Walls on page 361](#).
- Windows are placed relative to the outer surface of the outermost Main Layer.
- Exterior walls on different floors are aligned by the exterior edges of their outermost Main Layer.
- Roof baselines are placed at the outer edge of the outermost Main Layer when roofs are automatically generated. See [The Baseline on page 805](#).
- Roof baselines and gable/roof lines that are manually drawn snap to the outermost edge of the Main Layer.
- By default, walls resize about the exterior surface of their Main Layers when their thickness, wall type, or Wall Type Definition is changed. See [Resize About on page 375](#).
- **Object Snaps**  locate the interior and exterior edges of a wall's Main Layers. See [Object Snaps on page 160](#).
- The Sheathing Layer that windows and doors may be recessed to is the layer located just outside the outer Main Layer.

All of this information is reliant on the Main Layer, so creating your wall type definitions accurately beforehand and specifying the Main Layer correctly is very important.

## MULTIPLE MAIN LAYERS

In standard light frame construction, walls build to one another's framing layers, and floor and ceiling platforms are built to bear over the wall framing; however, some building techniques configure these components in other ways. You can control how walls of a given type are intersected, and also where platforms build to, by specifying multiple Main Layers.

- By default, when multiple Main Layers are specified:
- Intersecting walls build to the interior surface of the innermost Main Layer.

- Floor platforms build to the exterior surface of the outermost Main Layer.
- A selected wall's edit handles display along the exterior of the outermost Main Layer.
- The exterior surface of the outermost Main Layer is the Dimension Layer.



See *Wall Type Definitions Dialog on page 387*.

## THE DIMENSION LAYER

Dimension Defaults can be set to locate walls at their surfaces or at the exterior line of their Wall Dimension Layer. See *Locate Manual Panel on page 454*.

For installed wall types, the default Wall Dimension layer is the Main Layer; however, this can be changed in the Wall Type Definitions dialog. In addition to the Wall Dimension Layer, dimensions can locate the inside surface of the Main Layer, as well.

Whether Surface or Wall Dimension Layer is selected on the LOCATE OBJECTS panel of the Dimension Defaults dialog determines a number of aspects related to how dimensions locate walls:

- How Auto Exterior and Manual Dimensions measure the lengths of walls.
- Where both Manual and Automatic Reach are measured from.
- Where Extension line lengths and their Gap From Marked Object are measured from.
- Where First Line Offset for **Auto Exterior Dimensions**  is measured from.
- How the minimum enclosed area required by **Auto Exterior Dimensions**  is measured.

The settings on the LOCATE OBJECTS panel control how dimensions initially locate walls. Once a dimension line has been created, you can move its extension lines or add new extensions to locate other points along a wall's assembly. See *Measuring Walls on page 366*.

## INTERIOR AND EXTERIOR SURFACES

Every wall has an interior and exterior surface - including walls in a plan that are recognized by the program as being interior walls. See *Exterior and Interior Walls on page 351*.

Having separate designations for a wall's two sides serves several purposes:

- It allows the program to orient each wall's exterior side toward the outside of a structure. See *Creating Walls on page 357*.
- It allows you to specify different materials for each side's surface in the Wall Specification dialog. See *Materials Panel on page 405*.
- It also allows you to specify which direction Wall Detail views face. See *In Wall Detail Views on page 880*.

In the Wall Type Definitions dialog, the exterior surface is shown at the top of the Wall Layers table. In plan view, you can identify a selected wall's exterior surface by the location of its edit handles, which display on the exterior of the Main Layer by default. See *Resize About on page 375*.

## LEGACY WALL TYPES

In Chief Architect version X2 and prior, generic, single-layer wall types were used as the default for railings, deck railings and fencing. In the earliest program versions, they were the defaults for walls, as well.

- In Chief Architect X1 and prior, there were two such wall types: "Default (wood frame 16" OC)" and "Default (concrete)".
- In Chief Architect X2, these two wall types were replaced by one named "Adjustable Thickness Wall".

When plans that include either of these wall types - in the drawing itself or set as a default - are opened in Chief Architect X15, the legacy wall type is replaced by a new wall type named “Wall-X”, where X is the thickness of the wall’s Main Layer, rounded up. There are a few exceptions:

- If legacy wall types with the same thickness but different materials are found, they use the same naming convention appended with an additional *\_X*.
- If a wall using a legacy wall type is specified as a Foundation wall, the resulting wall type will be named “Foundation Wall-X”.
- If a legacy wall type has the same attributes as a wall type installed with Chief Architect X15, such as 8” Concrete Stem Wall, it will be replaced by that wall type.

Unless a wall is specified as a Foundation wall, Deck Railing, or Fencing, it will be treated as a framed wall and its new wall type will acquire two additional 1/2” (13 mm) thick wall layers: an interior and an exterior layer. These new layers will use the interior and exterior materials of the original wall. The wall’s original layer will maintain its original thickness, acquire a framing material, and will become the new wall type’s Main Layer.

Foundation, Deck Railing, and Fencing wall types converted in this manner will continue to have only one layer.

---

## Wall Type Definitions Dialog



The Wall Type Definitions dialog is used to define new wall types and redefine existing wall types in the current plan file. Select **Build> Wall> Define Wall Types** to open this dialog.

You can also click the **Define** button on the WALL TYPES panel of the Wall Specification dialog or in most Wall Defaults dialogs. See [Wall Types Panel on page 402](#).

Changes made to an existing wall type definition affect all walls in the current plan using that wall type. Walls in other plan files are unaffected.

If changes to a wall type affect its thickness, the position of any walls in the plan using that wall type may be affected. See [General Wall Defaults on page 343](#).

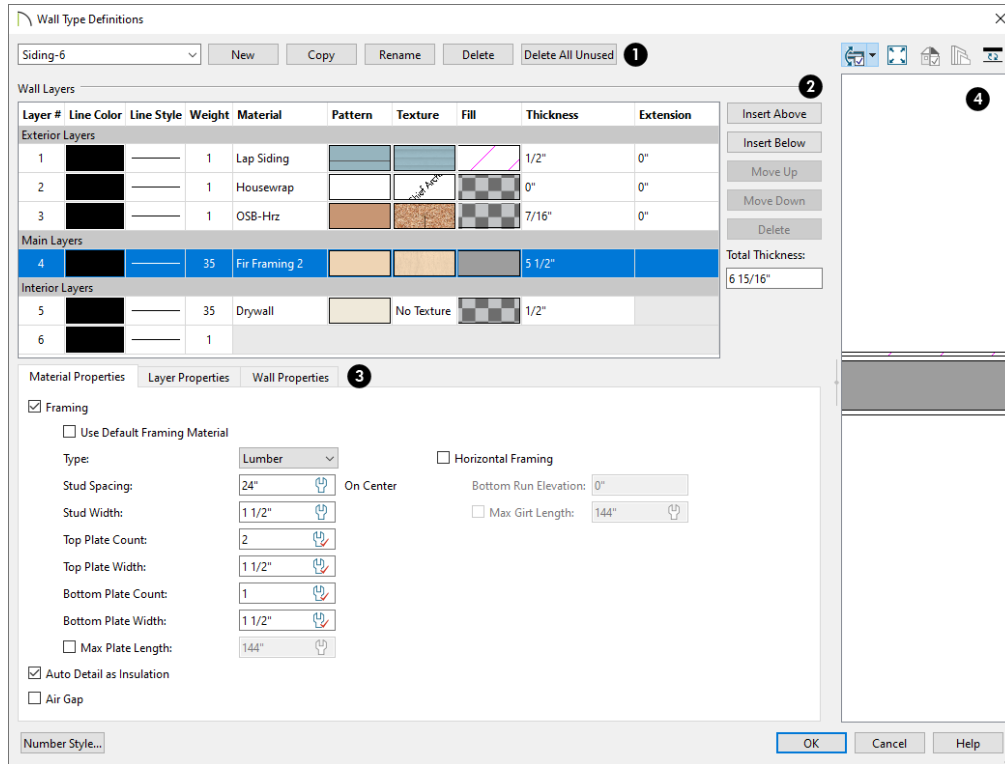

## 1 Wall Types

Manage the list of wall types available in the current plan. See *Wall Type Definitions on page 384*.

- Click the drop-down list to display all wall types in the current plan. Select a wall type from the list to display its definition. You can rename a wall type by typing in a new name. Note that wall type names in a plan must be unique.
- To create a new wall type, click **New** to define a new wall type from scratch or click **Copy** to copy the current wall type. A copied wall type can then be renamed and redefined.
- Click **Rename** to rename an existing wall type, or simply click on its name and type a new name.
- To remove a wall type from the current plan, select it and click **Delete**. Wall types that are in use or set as plan defaults cannot be deleted.
- To remove all wall types that are not in use or set as a default from the current plan, click **Delete All Unused**.

## 2 Wall Layers

The selected wall type's layers are listed here, from the exterior at the top to the interior at the bottom. The last item listed is the interior surface line rather than a true layer.

- The list is divided into three sections: Exterior, Main, and Interior Layers. To move a layer from one section to another, use the Move Up and Move Down buttons to the right.
- A wall type's thickest structural layer is typically set as the Main Layer; however, multiple Main Layers can be specified. See *The Main Layer on page 385*.

- Click in either the **Pattern** or **Texture** column to open the Select Material dialog and choose a material for the selected wall layer. See *Select Material/Library Object Dialog on page 1056*.
- Click in the **Fill** column to open the Layer Fill Style dialog and specify a fill style for the selected wall layer. See *Fill Styles on page 192*.

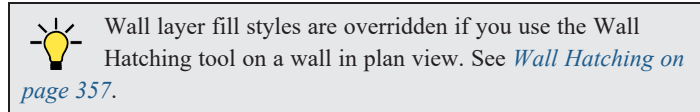

- Click in the **Thickness** column to type the selected layer's thickness, or depth. Very thin layers can be created, but for best results, avoid using a thickness of 0. For very small values, it can be helpful to temporarily change the dialog number format: click the Number Style button.
- Click in the **Extension** column to type how far the selected layer extends past its default bottom elevation, either at the bottom of the wall's bottom plate or that of the floor platform it builds on. Only available for Exterior wall layers, the highest Extension value is also applied to the wall type's Brick Ledge Depth, set on the Wall Properties Tab.

The buttons to the right of the table allow you to reorganize the wall type definition's layers.



- Click the **Insert Above** button to create a new layer directly above, or outside, the selected layer in the wall type definition. The new layer is a copy of the original.
- Click the **Insert Below** button to create a new layer directly below, or inside, the selected layer in the wall type definition. The new layer is a copy of the original.
- Click the **Move Up** button to swap the selected layer's position with that of the layer immediately outside it or to move it into the layer section directly outside it. Not available for the outer-most layer or for a single Main Layer.
- Click the **Move Down** button to swap the selected layer's position with that of the layer immediately inside it or to move it into the layer section directly inside it. Not available for the inner-most layer or for a single Main Layer.
- Click **Delete** to remove the selected layer from the wall type definition.
- The **Total Thickness** of the wall assembly displays here. If you change this value, the thickness of the Main Layer automatically updates to account for the difference.

### 3 Properties Tabs

Click on a tab to access various settings related to the functionality and appearance of the selected wall layer. See below.

### 4 Preview

A preview of the selected wall type definition displays here. See *Dialog Preview Panes on page 22*.

- When the selected preview type is a 3D view, a gap is shown between each of the wall layers in the preview. Click the **Explode Layers**  button remove or restore these gaps.
- When Plan View is the selected preview type, click the **Line Weights**  button to toggle the display of the wall layer and pattern line weights, or thicknesses. See *Line Weights on page 1374*.

## MATERIAL PROPERTIES TAB

Specify whether the selected wall layer has special attributes. Defaults for the Spacing, Width, Count, and Length settings can be set in the Framing Defaults dialog. See *Wall Panel on page 863*.

- Check **Framing** to produce framing in the selected layer when wall framing is generated. See *Framing Defaults on page 851*.
  - Check **Use Default Framing Material** to apply the default framing material set in the Build Framing dialog to the selected wall layer. See *Materials Panel on page 875*.
  - Select the framing **Type** from the drop-down list. See *Displaying Framing on page 879*.
  - Specify the on-center **Stud Spacing** of the selected wall layer. The default value is set in the Build Framing dialog. See *Wall Panel on page 863*.
  - Specify the **Stud Width** of the framing in the selected layer. The default value is set in the Build Framing dialog.
  - Specify the **Top Plate Count**, which is the number of plates stacked one above the other on top of the wall studs. When multiple plates are specified, their ends are staggered 48" (1200 mm).
  - Specify the **Top Plate Width**, which is the vertical thickness of the top plate(s).
  - Specify the **Bottom Plate Count**, which is the number of plates stacked under the wall studs.
  - Specify the **Bottom Plate Width**, which is the vertical thickness of the bottom plate(s).
  - Check **Max Plate Length**, then specify the maximum allowed length for the boards that make up the top and bottom plates. When unchecked, top and bottom plates run the entire length of each wall, regardless of its length. See *Export to EasyFrame on page 890*.
- Check **Auto Detail as Insulation** to generate Insulation boxes in the selected layer when **Auto Detail**  is used in cross section views. See *Detailing Cross Section/Elevation Views on page 1094*.
- Check **Air Gap** to prevent the selected layer from displaying in 3D views or being calculated in the Materials List.
- Check **Horizontal Framing** to produce framing that runs horizontally instead of vertically, sometimes referred to as girts.
  - When Horizontal Framing is checked, specify the **Bottom Run Elevation**. This value is absolute, measured from the center of the lowest horizontal framing member relative to zero, the default top height of the subflooring on Floor 1. For horizontal framing on Floor 0, enter the absolute elevation of the bottom run on that floor. See *Floor 1 Default Height on page 414*.
  - When Horizontal Framing is checked, check **Max Girt Length** and then specify the maximum allowed length for the girt boards. When unchecked, girt boards run the entire length of the wall, regardless of its length.

## LAYER PROPERTIES TAB

### 1 Selected Wall Layer Line

These settings define the selected layer's exterior line.

- Define the **Color**, **Style**, and **Weight** for the selected Wall Line.
- Check **By Layer** if you want the line to assume the attributes of the wall's layer as defined in the Layer Display Options dialog. See *Layer Attributes on page 177*.
- Click the **Library** button to select a **Line Style** from the Library. See *Line Styles on page 199*.

### 2 Exterior Layer Extensions

- Specify the **Extend Layer** value, which is how far the selected layer extends past its default bottom elevation, either at the bottom of the wall's bottom plate or that of the floor platform it builds on. Only available for Exterior wall layers, the highest Extension value is also applied to the wall type's Brick Ledge Depth, set on the Wall Properties Tab.

## WALL PROPERTIES TAB

### 1 Energy Values

Specify the selected wall type's **Energy Values**. This information is used when exporting to REScheck. See [Export to REScheck on page 1240](#).

- Select a **Wall Type** from the drop-down list. When “Framed” is selected, the on center spacing is derived from the material definition of the wall’s framing layer. See [Materials and the Materials List on page 1063](#).
- Specify a **Cavity R-Value** for the selected wall type definition.
- Specify a **Continuous R-Value** for the selected wall type definition.

### 2 Wall Settings

- Specify the **Brick Ledge Depth**, which is the vertical depth of the brick ledge under walls of this type when a Brick material Type is specified for the exterior layer and a monolithic slab foundation is built. See [Brick Ledges on page 353](#).

This setting will automatically equal the highest Extension value assigned to an exterior wall layer. If the Define Material dialog for the wall's exterior Brick material is accessed from this dialog, however, this value will instead be replaced by the Height value of the Brick material. See [Materials and the Materials List on page 1063](#).

- **Build Platform to Exterior of Layer** - Select a wall layer from the drop-down list to build floor and ceiling platforms to. By default, the exterior side of the outermost Main Layer is selected.

Note: If Build Platform to Exterior of Layer is set to the exterior wall layer, no siding material will generate to cover the floor platform.

- **Dimension to Exterior of Layer** - Select the wall type’s Dimension Layer from the drop-down list. By default, the outermost Main Layer is selected. This setting does not affect Interior Dimensions. See [The Dimension Layer on page 386](#).
- **Foundation to Exterior of Layer** - Select a wall layer from the drop-down list to align the Main Layer of a foundation wall or slab footing on the floor below to. By default, the outermost Main Layer is selected. See [Aligning Foundation Walls on page 377](#).
- **Foundation Offset** - Specify how far to offset the Main Layer of a foundation wall on the floor below relative to the Foundation to Exterior of Layer selected above. A positive value offsets toward the exterior; a negative value offsets toward the interior.
- Check **Partition Wall** to prevent walls of this type from cutting through the surface layers of floors, ceilings, and other walls. See [Partition Walls on page 362](#).

---

## Exporting and Importing Wall Types



Wall type definitions created in one plan can be exported as a **.dat** file and imported into other plans. This is a convenient alternative to re-creating one or more wall type definitions that already exist in another plan.

The wall type definitions available to export from the current plan are listed in the Wall Type Definitions dialog. See [Wall Type Definitions Dialog on page 387](#).

## EXPORTING WALL TYPES



To export wall type definitions from the current plan file, select **File> Export> Export Wall Definitions**.

The Export Wall Definitions File dialog is a typical Save File dialog. Exported wall types are saved using the **.dat** file extension. See [Exporting Files on page 41](#).

## IMPORTING WALL TYPES



To import wall type definitions into the current plan or layout, select **File> Import> Import Wall Definitions**.

The Import Wall Definitions File dialog is a typical Open File dialog. See [Importing Files on page 45](#).

When wall type definitions are imported, the names of the wall type definitions in the **.dat** file are compared with those already present in the current plan. If the program finds identical names, it will ask you if you want to replace existing wall definitions with the same name. Click Yes to replace existing files in the plan file, or No to keep the definitions already in the plan.



Wall type definitions that you use often should be saved in your default template plan. See [To create a plan template on page 89](#).

---

# Wall Specification Dialog



To open the Wall Specification dialog, select a wall or group of walls and click the **Open Object** edit button.

The panels of the Wall Specification dialog are also found in the Footing, Railing, Deck Railing, and Fencing Specification dialogs. See [Railing and Fencing Specification Dialogs on page 406](#).

The settings in this dialog are also similar to those in the various Wall Defaults dialogs. The settings in these defaults dialogs determine the initial characteristics of railings, deck railings, foundation walls and footing walls, and fencing when they are first drawn. See [Wall, Railing, and Fencing Defaults on page 343](#).

The Wall Specification dialog has the following panels:

## GENERAL PANEL

The settings on the GENERAL panel determine the basic use of the selected wall, as well as its length, angle, and other attributes.



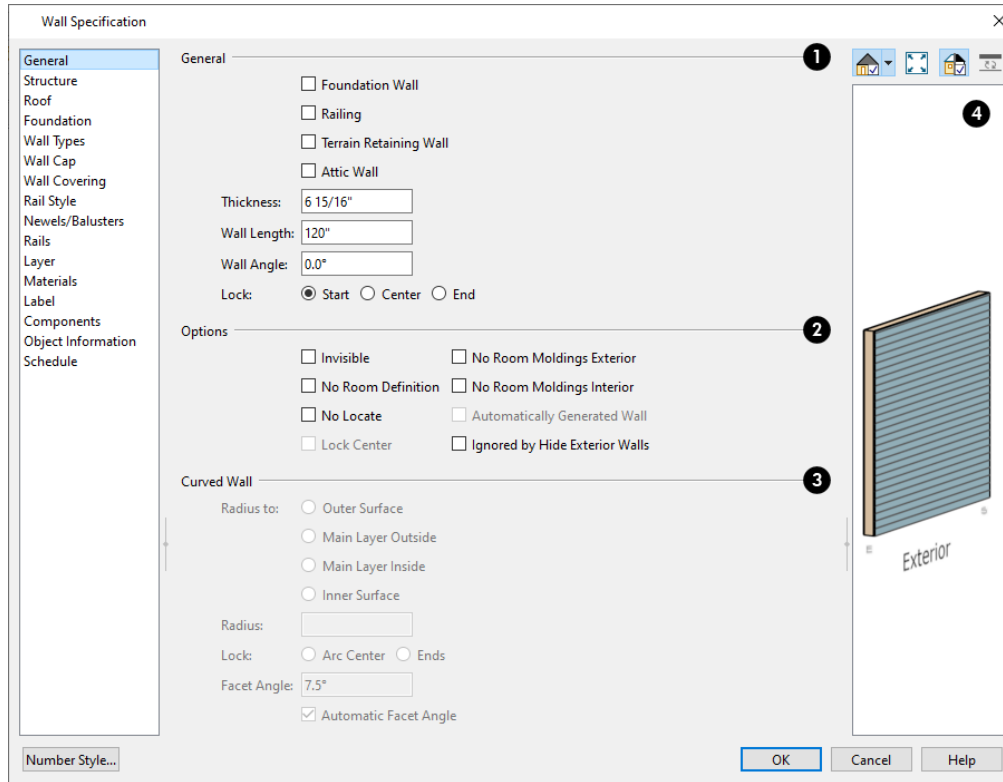



## 1 General

Specify **General** properties of the selected wall(s) or railing(s).

- Check **Foundation Wall** to specify the selected wall as a foundation wall. More foundation wall settings are available on the FOUNDATION panel. See [Foundation Walls on page 352](#).
- Check **Railing** to specify the selected wall as a railing. More railing settings are found on the RAILING, NEWELS/BALUSTERS, and RAILS panels. See [Railing and Fencing Specification Dialogs on page 406](#).
- Check **Terrain Retaining Wall** to treat the selected wall as a terrain retaining wall. See [Retaining Walls on page 1255](#).
- Check **Attic Wall** to prevent the selected wall from extending through the roof above. See [Attic Walls on page 380](#).
- The **Thickness** of the selected wall displays and can be changed here. If the wall is a Post to Overhead Beam railing, this setting can also affect the width of the beam. See [Wall Thickness on page 370](#).
- **Wall Angle** - The current absolute angle of the wall in plan view is shown. If you type in a new angle, the wall rotates about its locked point and any walls attached to it will not move. If the selected wall is curved, this value describes the angle of the chord and cannot be modified. See [3D Drafting on page 13](#).
- **Wall Length** - The current length, as measured along the **Resize About** line, is shown. If you type a new length, the wall will extend or contract according to how it is locked. Any walls attached to the selected wall will not move. If the selected wall is curved, this value cannot be modified. See [Resize About on page 375](#).
- Select a radio button to **Lock** the selected straight wall at its Start, End or Center. When the **Wall Angle** or **Wall Length** of the selected wall is changed, this point along the wall does not move. Not available for curved walls.

## 2 Options

- Check **Invisible** to specify the wall as invisible. Invisible walls can display in plan view but not in 3D views or the Materials List. **Room Dividers**  are invisible by default. See *Room Dividers and Invisible Walls on page 355*.
- Check **No Room Definition** to display the wall in floor plan and/or 3D views but not create room definition. This box is checked and inactive when the selected wall is set to be a Furred Wall on the STRUCTURE panel. See *Room Definition on page 413*.
- Check **No Locate** to prevent **Auto Exterior Dimensions**  from locating the wall in plan view. See *No Locate on page 368*.
- Check **Lock Center** to prevent the arc center of a selected curved wall from moving when the wall is edited using its edit handles. Not available for straight walls.
- Check **No Room Moldings Exterior** to prevent any room moldings from generating along the Exterior side of the selected wall. If a Room Molding Polyline is created, it will also be affected by this setting. See *Room Moldings on page 436*.
- Check **No Room Moldings Interior** to prevent any room moldings from generating along the Interior side of the selected wall. If a Room Molding Polyline is created, it will also be affected by this setting.
- **Automatically Generated Wall** displays for reference and is checked whenever the selected wall was generated by the program. Typically, automatic walls are also Attic walls.
- Check **Ignored by Hide Exterior Walls** to prevent the selected wall from being hidden in 3D views when the Hide Camera-Facing Exterior Walls option is in use. See *Hide Camera-Facing Exterior Walls on page 1135*.

## 3 Curved Wall

The **Curved Wall** settings control the definition of a selected curved wall's radius and are only available when the selected wall is curved.

- Select **Outer Surface** to measure the selected wall's radius from its center point to its outer surface.
- Select **Main Layer Outside** to measure the radius from the wall's center point to the outside of its Main Layer. See *The Main Layer on page 385*.
- Select **Main Layer Inside** to measure the radius from the wall's center point to the inside of its Main Layer.
- Select **Inner Surface** to measure the radius from the wall's center point to its inner surface.
- Specify the selected wall's **Radius**, as defined by the radio button selected above.
- Select **Arc Center** to move the selected wall's ends and prevent its center point from moving when its Radius is changed.
- Select **Ends** to move the selected wall's center point and prevent its ends from moving when its Radius is changed.
- Uncheck **Automatic Facet Angle** to specify the **Facet Angle**, which is the angle at which the surfaces of the curved wall are broken in 3D views. The default value is 7.5°; a smaller value produces a smoother curve but may take longer to generate in 3D views.

## 4 Preview

A preview of the selected wall, including any doors or windows inserted into it, displays on the right. If the selected wall is specified as Invisible, its plan view will display here by default. See *Dialog Preview Panes on page 22*.

## STRUCTURE PANEL

The settings on the STRUCTURE panel control the height and other structural attributes of the selected wall(s).

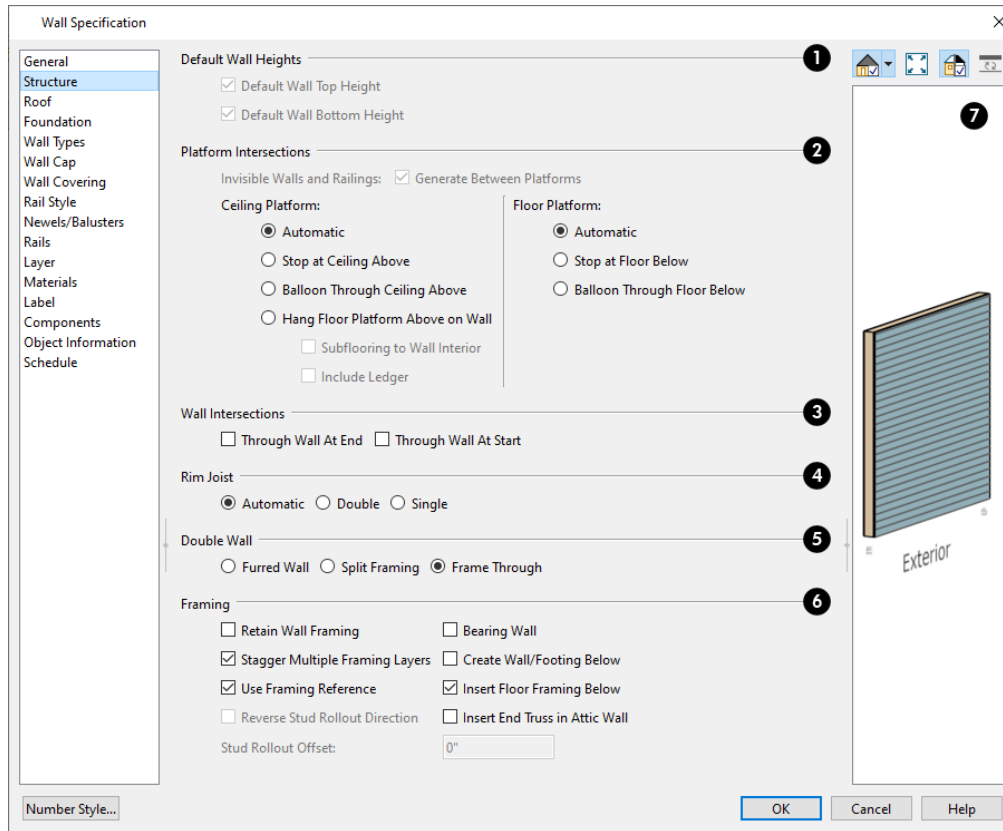

### 1 Default Wall Heights

The **Default Wall Heights** settings allow you to reset a wall's default top and bottom heights if they have been manually edited. See [Wall Heights on page 371](#).

- **Default Wall Top Height** and **Default Wall Bottom Height** are only enabled if the selected wall's top and/or bottom height has been edited. Check these boxes to restore the default heights.

### 2 Platform Intersections

These settings control the relationship between the selected wall and the **Ceiling Platform** above and the **Floor Platform** below it. They only take effect when the selected wall is positioned at a platform edge, such as at the exterior of a building or Open Below room. See [Floor and Ceiling Platforms on page 428](#).

- Check **Generate Between Platforms** to fill in the gap between floor and/or ceiling platforms when the selected railing or invisible wall separates rooms with different floor and/or ceiling heights. When unchecked, this gap is not closed. Only available for railings, Invisible railings, and Invisible walls, this setting has no effect when the selected wall type has only one layer.

The **Ceiling Platform** settings control how the selected wall's top plates are generated.

- Select **Automatic** to set the wall's top plates under the ceiling above if there is a floor/ceiling platform above, or to balloon frame the wall if there is not a platform above.

- Select **Stop at Ceiling Above** to have the top of the wall top at the bottom of the ceiling platform above, as is typical in light frame construction.
- Select **Balloon Through Ceiling Above** to have the top of the wall go past the ceiling platform. If there is a framed wall directly above, the framing will continue upward to that wall's top plate. The two walls remain separate objects on different floors, however, unless the wall above is an Attic Wall. This setting does not affect interior walls.
- Select **Hang Floor Platform Above on Wall** to produce a platform that hangs on the inside of the selected wall rather than bearing on top of it. When checked, the two options that follow are available.
- Select **Subflooring to Interior Wall** to produce subflooring that builds to the inside surface of the wall. When unchecked, the subflooring builds over the top of the wall to the outside of its Main Layer. The wall's top height may be lowered to accommodate a sill plate. See *Floor and Ceiling Platform Definitions on page 429* and *The Main Layer on page 385*.
- Select **Include Ledger** to hang the platform from a ledger board attached to the wall. When unchecked, no ledger is created when platform framing is generated. See *Floor and Ceiling Framing on page 851*.

The **Floor Platform** settings control how the selected wall's bottom plate is generated.

- Select **Automatic** to set the wall's bottom plate on top of the floor platform below, or to balloon frame the wall if there is not a platform below. If the wall is a Concrete type, the floor platform instead hangs on the inside the selected wall. See *The Main Layer on page 385*.
- Select **Stop at Floor Below** to have the bottom of the wall stop at the top surface of the floor platform, as is typical in light frame construction.
- Select **Balloon Through Floor Below** to have the bottom of the wall go through the floor platform below. If the selected wall is framed and there is a framed wall directly below, the studs of the wall below will extend up produce balloon framing. If the wall below is set to Stop at Ceiling Above, the selected wall's bottom plates will rest on that wall's top plates. This setting does not affect interior walls.

Note: Whether a wall is a framed or concrete type is determined by the material assigned to its Main Layer. See *Wall Type Definitions Dialog on page 387*.

### 3 Wall Intersection

The **Wall Intersection** settings control whether the selected wall builds through wall corners at its Start and End points. The display of **Start and End Indicators** can be turned on or off in the Preferences dialog. See *Edit Panel on page 115*.

- Select **Through Wall at Start** to build the wall through the wall corner located at its start point.
- Select **Through Wall at End** to build the wall through the wall corner located at its end point.
- When neither box is checked, the program will determine whether the wall builds through the corners at each of its endpoints.

### 4 Rim Joists

Specify the number of **Rim Joists** for the floor platform below the selected wall(s). See *Framing on page 850*.

- Select **Single** or **Double** to generate one or two rim joists, respectively.
- Select **Automatic** to generate two rim joists if there is no wall below the selected wall, and one rim joist when there is a wall below. Automatic produces a single rim joist for Deck Railing.

## 5 Double Wall

These options specify how a selected straight wall frames when it is parallel to and touching a second wall. Not available for curved walls. See *Double Walls on page 382*.

- Select **Frame Through** to create a basic double wall.
- Select **Split Framing** to create a double wall that splits platforms and connecting walls at its boundary.
- Select **Furred Wall** to treat the selected wall as additional layers added to another wall. When Furred Wall is selected, No Room Definition is automatically checked on the GENERAL panel.

## 6 Framing

- Check **Retain Wall Framing** to preserve the framing of the selected wall when the wall framing is globally rebuilt. See *Keeping Framing Current on page 884*.
- Check **Stagger Multiple Framing Layers** to produce wall studs that are offset from one another when wall framing is created. This setting only has an effect if a wall type with multiple Framing layers is specified. See *Wall Type Definitions Dialog on page 387*.
- Check **Use Framing Reference** to use a Framing Reference Marker as the starting point for the selected wall's stud layout. When unchecked, stud rollout begins at the wall's Start. See *Framing Reference Markers on page 875*.
- Check **Reverse Stud Rollout Direction** to begin stud rollout at the selected wall's End instead of its Start. Only available when Use Framing Reference is unchecked. The display of **Start and End Indicators** can be turned on or off in the Preferences dialog. See *Edit Panel on page 115*.
- Specify the **Stud Rollout Offset**, which is the distance from the selected wall's Start or End that you want stud rollout to begin. Only available when Use Framing Reference is unchecked.
- Check **Bearing Wall** to specify the selected wall as load-bearing. When checked, automatically generated joists run perpendicular to the selected wall and either lap or butt over it, as specified in the Build Framing dialog. See *Floor and Ceiling Framing on page 851*.
- Check **Create Wall/Footing Below** to create a stem wall or slab footing below the selected wall on Floor 1 when an automatic foundation is built. Has no effect if the selected wall is on any floor other than Floor 1. See *Building a Foundation on page 710*.

Note: If **Create Wall/Footing Below** is checked, **Foundation Wall** and **Slab Footing** will become unchecked on the *Foundation Panel on page 400*.

- When **Insert Floor Framing Below** is checked, extra floor joists will be generated under the selected wall for support if the wall in question is parallel with the joists below. Uncheck this box for joists generated at regular layout. Extra joists can be added manually if desired. See *Floor and Ceiling Framing on page 851*.
- Check **Insert End Truss in Attic Wall** to generate a Reduced Gable End Truss in the Attic wall above the selected wall when roof trusses are generated. See *Roof Truss Specification Dialog on page 912*.

## 7 Preview

A preview of the selected wall, including any doors or windows inserted into it, displays on the right. See *Dialog Preview Panes on page 22*.

## ROOF PANEL

Any automatically generated roof style other than a hip requires roof information to be defined in the exterior walls. On the ROOF panel, you can specify how the selected wall interacts with the roof plan, defining the portion of the roof plan that bears on it. See *Automatic vs. Manual Roofs on page 792*.

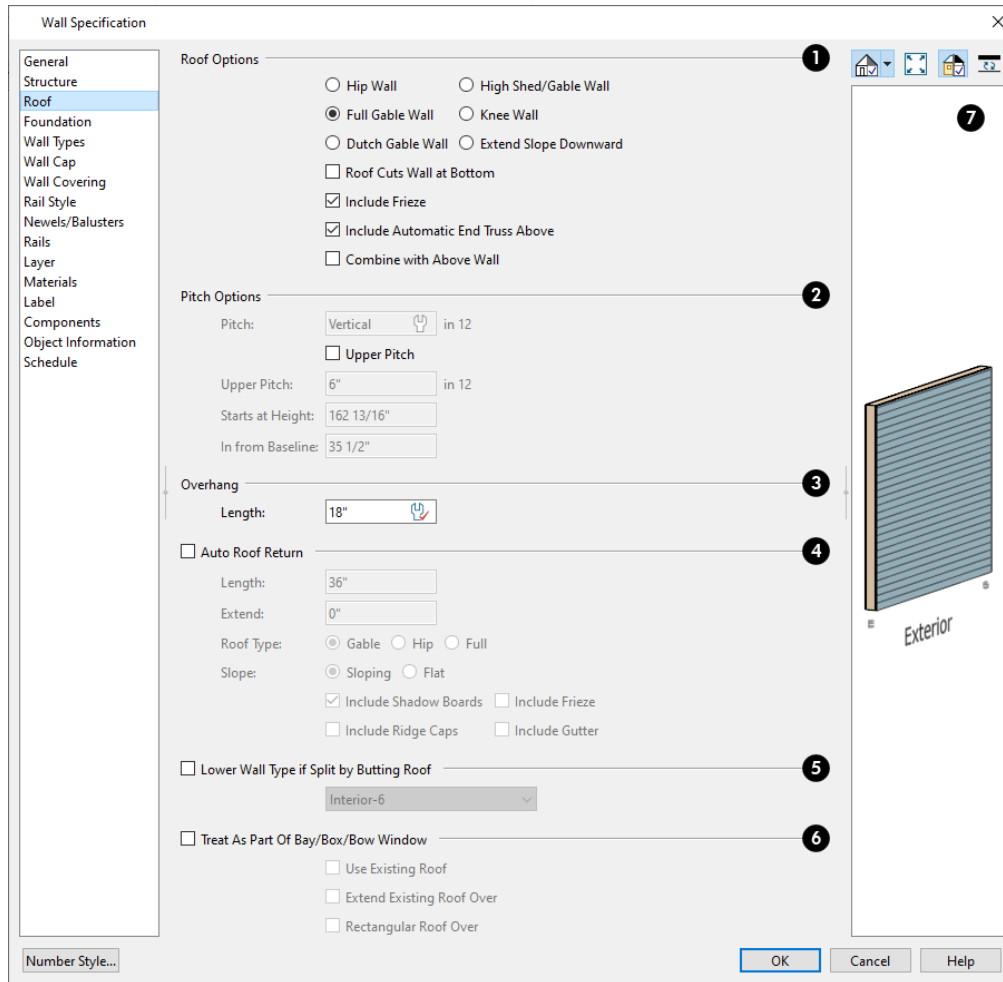

### 1 Roof Options

Specify the shape of the wall relative to the roof.

- Select **Hip Roof** to create a roof plane that bears on top of the selected wall.
- Select **Full Gable Wall** to create a gable end over the selected wall.
- Select **Dutch Gable Wall** to create a small gable part way up a hip roof. Use the Pitch Options below to specify the location of the gable.
- Select **High Shed/Gable Wall** to specify the selected wall as the high end of a shed roof.
- Select **Knee Wall** to define the selected interior wall as a knee wall. Only an interior wall can be defined as a knee wall. A knee wall's height is defined by the roof above, not the ceiling height. See *Knee Walls on page 380*.
- Select **Extend Slope Downward** to continue a roof down over a bump-out in an exterior wall. See *Extend Slope Downward on page 378*.

- Check **Roof Cuts Wall at Bottom** to prevent the portion of a selected wall located below an intersecting roof plane from building.
- When **Include Frieze** is checked, the frieze molding specified in the Build Roof dialog is generated along the selected wall at the roof line. Uncheck this to prevent the frieze from generating. See *Frieze Molding on page 847*.
- When **Include Automatic End Truss Above** is checked and there is an Attic wall above the selected wall, that Attic wall will receive an End Truss when roof trusses are automatically generated. See *Roof Trusses on page 895*.
- **Combine with Above Wall** is only available when a selected wall has an Attic wall above it. Check this box to balloon frame the two walls when automatic framing is built. The two walls remain separate objects. See *Attic Walls on page 380*.

## 2 Pitch Options

Specify the pitch or pitches of the roof plane(s) above the selected wall.

- Enter a value to define the **Pitch** of the roof plane bearing on the selected wall.
- Check **Upper Pitch** to create a roof with two pitches or, if the selected wall is a Full Gable Wall, a half hip condition.
- Enter the **Pitch** of the second, upper roof.
- Specify the **Height** that the Upper Pitch **Starts at**, or define the distance **In from Baseline** that the second pitch begins. The two values are dynamic. Press the Tab key to update the relative numbers. These settings are also used to position a Dutch Gable Wall.

## 3 Overhang Length

Specify the **Overhang Length**, which is the horizontal distance from the baseline to the eave. See *The Baseline on page 805*.

## 4 Auto Roof Return

Check **Auto Roof Return** to generate roof returns on the selected wall. In most cases, roof returns only work for Full Gable Walls. See *Roof Returns on page 844*.

- Specify the horizontal **Length** of the roof return in inches (mm).
- Enter a value in inches (mm) to **Extend** the roof returns past the overhang.
- Specify a **Gable, Hip, or Full** roof return.
- Specify a **Sloping or Flat** roof return.
- Check the boxes to **Include Shadow Boards, Ridge Caps, Frieze** molding, and/or **Gutters** on the roof returns.

## 5 Lower Wall Type if Split by Butting Roof

Check **Lower Wall Type if Split by Butting Roof** to specify the wall type for any portion of the selected wall located beneath an adjacent, abutting roof plane, should one be present. A wall affected by this setting is specified as a Pony Wall and the upper wall is defined on the WALL TYPES panel. See *Exterior/Interior Pony Walls on page 379*.

## 6 Treat As Part Of Bay/Bow/Bow Window

These options correspond to the **Roof** options in the Bay/Bow/Bow Window Specification dialog and should only be used by groups of three or more walls that form a bay or bow shaped bump-out. See *Bay, Box, Bow Windows and Roofs on page 610*.

- Check **Treat As Part Of Bay/Box/Bow Window** to create a hip roof with California ridge over the bump-out formed by the selected walls when the roof is rebuilt.
- Check **Use Existing Roof** to ignore the bump-out formed by the selected walls when the roof is rebuilt.
- Check **Extend Existing Roof Over** to extend the eave of the main roof plane to cover the bump-out created by the selected walls and follow its footprint.
- Check **Rectangular Roof Over** to create a rectangular hip roof over the bump-out formed by the selected walls instead of one that follows its footprint.

## 7 Preview

A preview of the selected wall, including any doors or windows inserted into it, displays on the right. See *Dialog Preview Panes on page 22*.

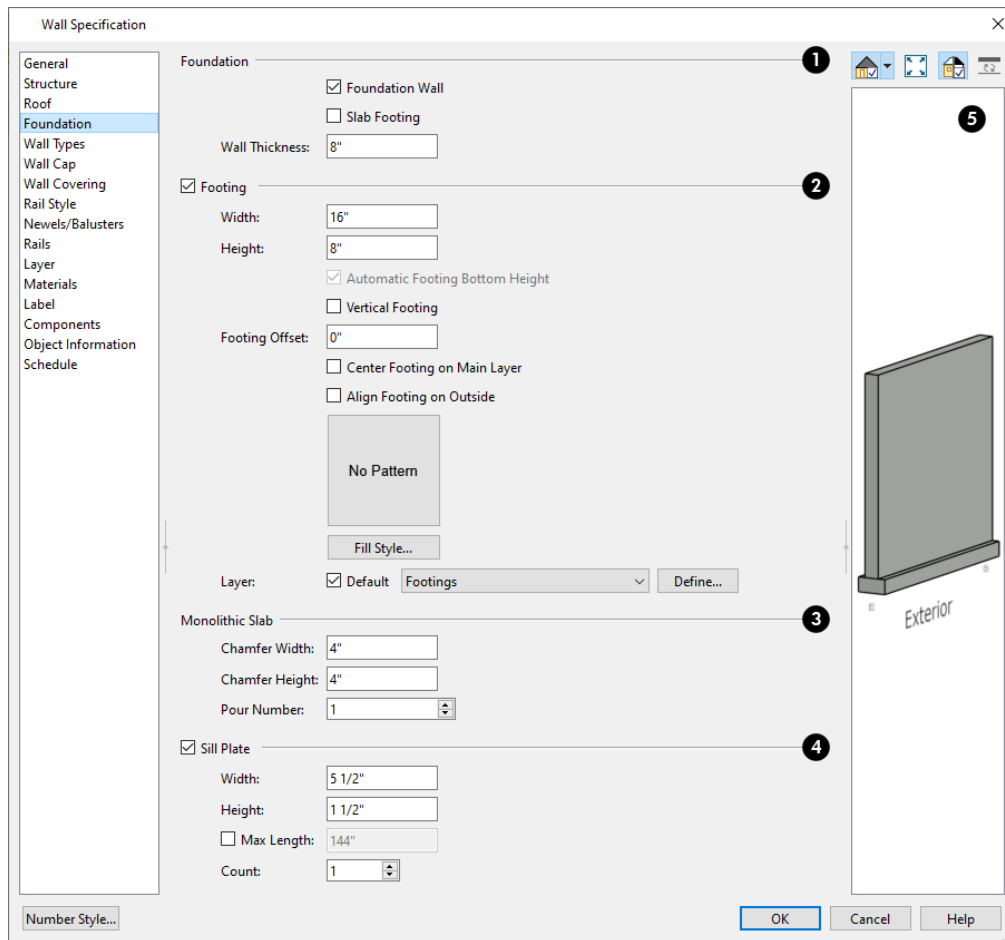

## FOUNDATION PANEL



## 1 Foundation

Specify the **Foundation** properties of the selected wall(s).



- Check **Foundation Wall** to specify the selected wall as a foundation wall and enable additional settings on this panel. This box is checked by default for automatically generated foundation walls as well as walls drawn with the **Foundation Wall tool**  and **Slab Footing tools** .
- Check **Slab Footing** to specify the selected wall as a slab footing. See *Foundation Walls on page 352*. When this is checked, **Foundation Wall** will also be checked.

Note: Rooms defined by walls drawn using the Slab Footing tool will have a Ceiling Height of 0 and a Monolithic Slab Foundation. Rooms defined by walls that are later specified as Slab Footings will not unless the room is on Floor 0 and the plan has a Monolithic Slab foundation specified.

- The **Wall Thickness** of the selected wall displays and can be changed here.
- If Slab Footing is checked, the **Curb Width** can be specified instead.

## 2 Footing

Check **Footing** to assign a concrete footing to the selected wall(s) and enable the settings below. Only available when **Foundation Wall** is checked, above.

- Specify the **Width** and **Height** of the footing below the selected foundation wall(s). The **Height** value will be unavailable if the bottom height of the footing has been edited. See *Stepped Foundations on page 718*.
- Check **Automatic Footing Bottom Height** to restore the default height of the selected wall's footing. Only available when the footing bottom height has been edited.
- Check **Vertical Footing** to generate footings that run up and down along any steps in the foundation wall's bottom height.
- Specify the **Footing Offset**, which is the distance between the center of the footing and the center of the wall. A value of 0 centers the footing under the wall; a positive value offsets the footing towards the wall's interior surface; and a negative value offsets it towards the wall's exterior. Not available if either **Center Footing on Main Layer** or **Align Footing on Outside** are checked, below.
- Check **Center Footing on Main Layer** to center the footing on the wall's Main Layer. See *The Main Layer on page 385*.
- Check **Align Footing on Outside** to align the footing along the wall's exterior surface. See *Wall Type Definitions on page 384*.
- Click the **Fill Style** button to specify a custom fill for the selected wall's footings. A preview of the fill displays in the pane above the button. See *Fill Styles on page 192*.
- Specify the **Layer** that the selected wall's footing is drawn on. See *Layer Panel on page 186*.

## 3 Monolithic Slab

Specify how **Monolithic Slab** footings generate. These settings apply only when the selected wall defines the side of a Monolithic Slab. See *Foundations on page 705*.

- Specify the **Chamfer Width** and **Height**, which define the angled corners where the footing meets the underside of the slab.
- Specify the **Pour Number** of the selected Slab Footing. Pour Numbers are listed separately in the Materials List. See *In the Materials List on page 712*.

#### 4 Sill Plate

Check **Sill Plate** to reserve space for one or more sill plates, or mud sills between the selected foundation stem wall or grade beam and the floor platform or framed wall that bears on it. Sill plates are generated when the floor framing is generated. See *Sill Plates on page 853*.

- Specify the **Width** and **Height** of the treated sill plates. If the Height is set to zero, no sill plates are produced. Not available if **Monolithic Slab** is the selected **Foundation Type**.
- Specify the **Max Length**, then specify the maximum allowable length for sill plate boards generated over the selected wall. When unchecked, sill plates run the full length of the wall, regardless of length.
- Specify the **Count**, which is the number of sill plates stacked vertically on each stem wall or grade beam.

#### 5 Preview

A preview of the selected wall, including any doors or windows inserted into it, displays on the right. See *Dialog Preview Panes on page 22*.

### WALL TYPES PANEL

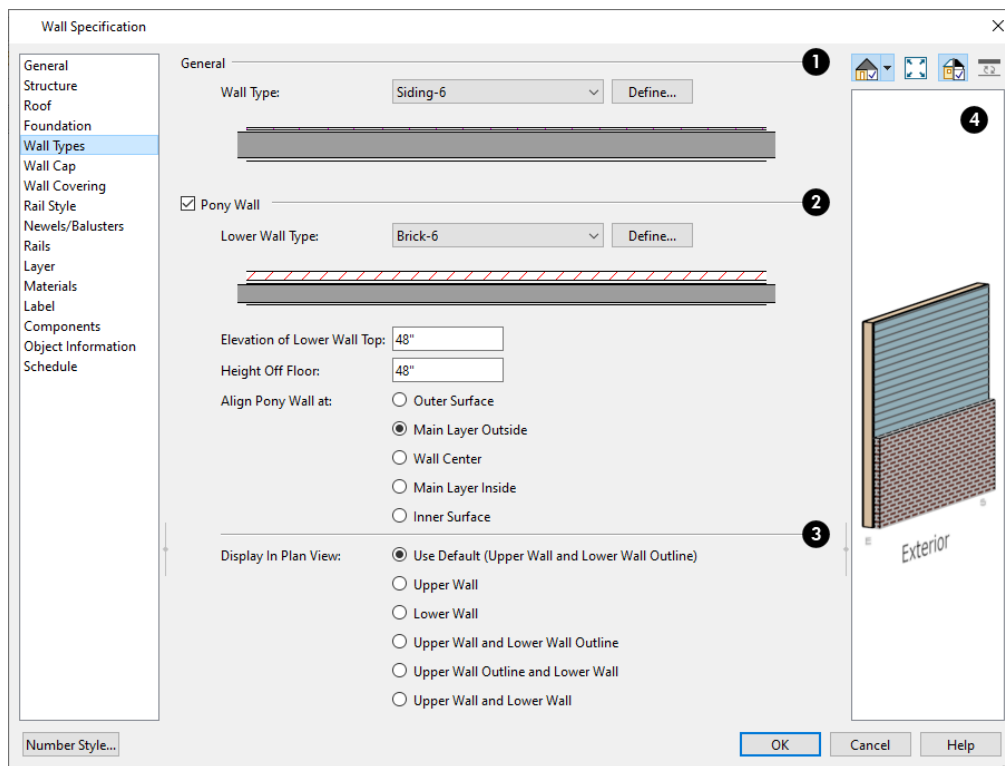

#### 1 Wall Type

Choose the selected wall's **Wall Type** from the drop-down list of all currently available types. A preview of the selected wall type displays below the drop-down list.

- Click the **Define** button to open the Wall Type Definitions dialog to create or modify existing wall types. See *Wall Type Definitions Dialog on page 387*.

#### 2 Pony Wall

Check **Pony Wall** to specify the selected wall as a pony wall having different wall types on its upper and lower portions.

See *Pony Walls on page 354*.

If the selected wall is a Foundation Wall, its initial wall type will become the Lower Wall Type. For all other walls, the initial wall type will be the upper Wall Type.

- Select the **Lower Wall Type**, the wall type of the lower portion of the pony wall, from the drop-down list. A preview of the selected wall type displays directly below.
- Click the **Define** button to open the Wall Type Definitions dialog.

Specify the height of the division between the upper and lower walls. These two settings are dynamic: if one is changed, the other will update accordingly.

- Specify the **Elevation of Lower Wall Top**, which is the division between the upper and lower walls. If the top of the lower pony wall is stepped or raked, this value will be “No Change”. This is an absolute value: regardless of the wall’s location, it is always measured from 0” (mm) - the default floor height for Floor 1. See *Floor Defaults Dialog on page 731*.
- Specify the **Height Off Floor** of the division between the upper and lower walls. This value is measured from the floor height of the room(s) defined by the selected wall. If the wall defines rooms with different floor heights, “No change” will display.

**Align Pony Walls** - Specify how the layers of the selected wall’s Upper and Lower portions align.

- Select **Outer Surface** to align wall types at their outer surfaces.
- Select **Main Layer Outside** to align wall types at the exterior edge of their main layers.
- Select **Wall Center** to align the centers of the main layers of both wall types.
- Select **Main Layer Inside** to align the wall types at the interior side of their main layers.
- Select **Inner Surface** to align wall types at their interior surfaces.
- **No Change** is used by default when multiple pony walls with different alignment settings are selected. Choose this to leave the alignment as it was when the dialog was opened.

Specify which part of the pony wall you would like to **Display in Plan View**. See *Displaying Pony Walls on page 354*.

- Select **Default** to display the portion of the pony wall specified in the Pony Wall Defaults dialog. The default portion is stated in parentheses.
- Select **Upper Wall** to display the upper portion of this pony wall in plan view regardless of the default setting.
- Select **Lower Wall** to display the lower portion of this pony wall in plan view regardless of the default setting.
- When walls are group-selected, choose **No Change** to allow each wall in the selection set to maintain its own setting.

In the Pony Wall Defaults dialog only, specify the **Display of Openings in Non-Displayed Parts of Walls**. This controls how doors and windows display in plan view when they are located entirely in the part of a pony wall that is not visible.

- Select **Outline** to display the lines associated with openings but draw the wall layers’ lines and fill through them.
- Select **Always** to display doors and windows the same regardless of where they are located: drawing their outlines and preventing wall layers from drawing through them.
- Select **Hide** to not draw door and window outlines at all, so they cannot be seen.

Note: The Display of Openings in Non-Displayed Parts of Walls as well as the default Display in Plan View settings can be set differently in each Saved Plan View. See [Plan Views on page 146](#).

### 3 Preview

A preview of the selected wall, including any doors or windows inserted into it, displays on the right. See [Dialog Preview Panes on page 22](#).

### WALL CAP PANEL

The settings on the WALL CAP panel allow you to apply a cap to the top of a wall or, if the wall is a Pony Wall, over the top of the lower Pony Wall. See [Lower Pony Wall Caps on page 355](#).

The settings on this panel are like those on the MOLDINGS panel found in a variety of dialogs in the program. See [Moldings / Profiles / Rails / Panels on page 927](#).

### WALL COVERING PANEL

The WALL COVERING panel is also available in the Room Specification dialog. See [Room Specification Dialog on page 437](#).

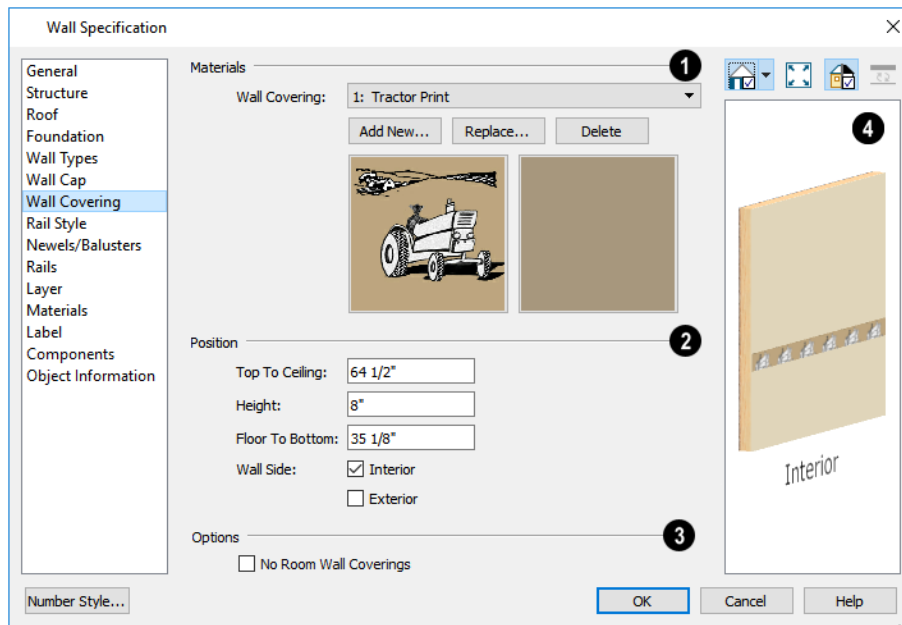

### 1 Materials

All wall covering materials applied to the selected wall are listed here. Select one from the drop-down list to edit its position or remove it from the wall.

- Click **Add New** to apply a new wall covering to the selected wall. See [Select Library Object Dialog on page 974](#).
- Click **Replace** to replace the current wall covering with a new one from the library.
- Click **Delete** to remove the current wall covering from the selected wall.

Preview panes showing the current wall covering display the row of buttons.

## 2 Position

Specify the **Position** of the selected wall covering.

- Enter the heights of the current wall covering's **Top To Ceiling** and **Floor To Bottom**. The wall covering's **Height** from its top edge to its bottom edge can also be specified.
- Check **Interior** and/or **Exterior** to apply the wall covering to the inside and/or outside of the selected wall. Interior is checked by default. Not available for rooms. See *Wall Type Definitions on page 384*.

## 3 Options

Check **No Room Wall Coverings** to prevent any wall coverings assigned to rooms from generating on the selected wall.

## 4 Preview

Most wall coverings are best previewed using the Standard Rendering Technique. See *Dialog Preview Panes on page 22*.

### RAIL STYLE PANEL

The settings on the RAIL STYLE panel are only available for Railings, Half Walls, Deck Railings, and Fencing. See *Rail Style Panel on page 407*.

### NEWELS/BALUSTERS PANEL

The settings on the NEWELS/BALUSTERS panel are only available for Railings, Half Walls, Deck Railings, and Fencing. See *Newels/Balusters Panel on page 409*.

### RAILS PANEL

The settings on the RAILS panel are used to specify the style and size of the horizontal components of a selected Railing, Deck Railing, or Fence. See *Railing and Deck Tools on page 349*.

A similar panel is also found in the Staircase and Ramp Specification dialogs and has additional settings for handrails at walls. See *Rails Panel on page 783*.

The settings on this panel are like those on the MOLDINGS panel found in a variety of dialogs in the program. See *Moldings / Profiles / Rails / Panels on page 927*.

### LAYER PANEL

For information about the settings on this panel, see *Layer Panel on page 186*.

### MATERIALS PANEL

All walls - including interior walls, railings and fencing - have an "Exterior Wall Surface" and an "Interior Wall Surface". See *Interior and Exterior Surfaces on page 386*.

The materials specified on the MATERIALS panel affect the appearance of walls and Solid Railings in 3D views but are not calculated in the Materials List. See *Materials Lists on page 1303*.

For most railing types, the "Exterior Wall Surface" component only affects the appearance of the floor platform under the railing and the "Interior Wall Surface" component is not used. For fencing, neither material component is used.

### **LABEL PANEL**

Wall labels display in plan view and cross section/elevation views when the “Walls, Labels” layer is turned on and use the Text Style assigned to that layer. See *Wall Labels on page 364*.

For information about the settings on this panel, see *Label Panel on page 700*.

### **COMPONENTS PANEL**

The information on the COMPONENTS panel can be used in the materials list. For more information, see *Components Panel on page 1330*.

### **OBJECT INFORMATION PANEL**

The information entered on the OBJECT INFORMATION panel can be used in schedules and the materials list. For more information, see *Object Information Panel on page 1331*.

### **SCHEDULE PANEL**

The settings on the SCHEDULE panel determine which schedule categories the selected wall is included in. See *Schedule Panel on page 704*.

---

## **Railing and Fencing Specification Dialogs**

 To open the Railing or Fencing Specification dialog, select a railing or fencing, or a group of railings or fencing, and click the **Open Object** edit button.



The Railing and Fencing Specification dialogs are the same as the Wall Specification dialog, but have three panels that apply only to Railings, Half Walls, Deck Railings, and Fencing. See *Wall Specification Dialog on page 392*.

The RAILS panel is similar to the HANDRAIL panel found in the Staircase and Ramp Specification dialogs. See *Stairs, Ramps, and Landings on page 742*.

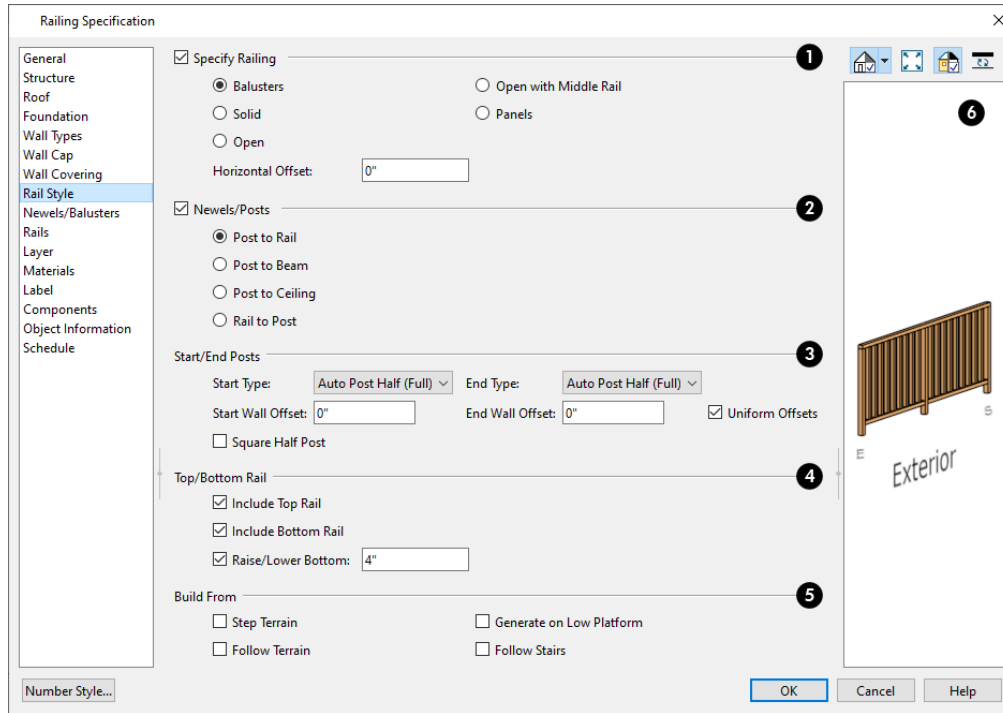
## RAIL STYLE PANEL



### 1 Specify Railing

Check **Specify Railing** to specify the selected wall as a railing and enable the other options on this panel. Railings drawn using the **Railing**  or **Deck Railing**  tools have this checked by default.

- Select the radio button for the desired **Railing Type**:
- Select **Balusters** to create regularly spaced balusters between larger newel posts.
- Select **Solid** to create a solid railing or Half Wall. Not available if the selected railing is also a Pony Wall. See [Pony Walls on page 354](#).
- Select **Open** to create a railing with only newel posts and top and bottom rails.
- Select **Open with Middle Rail** to create a railing with newel posts and top, bottom, and middle rails.
- Select **Panels** to create a railing composed of panels, then click the **Library** button to select a panel style from the Library Browser. See [Select Library Object Dialog on page 974](#). You can specify the panel style on the NEWELS/BALUSTERS panel. See [Newels/Balusters Panel on page 409](#).
- Specify a **Horizontal Offset**, which allows you to place the railings either inside or outside their default location. A positive value offsets the railings in the direction of their interior surface, while a negative value offsets them outward. Room definition is not affected by this offset so you can offset a railing relative to the floor platform edge it defines.

### 2 Newels/Posts

- Check **Newels/Posts** to assign these to the selected railing, then specify their properties:
  - Select **Post to Rail** to create newel posts from the floor to the top rail. This option is selected by default.
  - Select **Post to Beam** to create newel posts from floor to a beam placed just under the ceiling height. The beam's width is based on the Thickness of the selected railing wall.
  - Select **Post to Ceiling** to extend the newel posts to the ceiling.
  - Select **Rail to Post** to produce newel posts of the Height specified on the NEWELS/BALUSTERS panel, with rails that build to the sides of the newels.

### 3 Start/End Posts

If either the Start or End of the selected railing is connected to another railing, the settings associated with that end will not be available. These options are not available at all when **Newels/Posts** is unchecked above.

- Select the **Type** of post at the railing's **Start** and **End** points: "Full Post", "Half Post", or "None." The "Auto Post" options place either a Half post or None if the railing intersects a wall and a Full post otherwise: the currently applicable Type is indicated in parentheses. A Full Post is always placed where railings meet at a corner.
- Specify the **Start** and **End Wall Offsets**, which are the distances between the railing's half posts and the intersecting wall.
- Check **Uniform Offsets** to apply the same offset to both ends of the railing.
- Check **Square Half Post** to use a square half post where the railing intersects a wall instead of the post Type specified on the NEWELS/BALUSTERS panel. This only applies when a railing end is set to have a Half Post.

### 4 Top/Bottom Rail

These options control the placement of the top and bottom rail, or shoe.

- Uncheck **Include Top Rail** to eliminate the top rail.
- Uncheck **Include Bottom Rail** to eliminate the bottom rail and extend the balusters to the floor. Not available for Solid railings.
- Check **Raise Bottom**, then specify the **Floor to Bottom** distance, measured up from the floor platform to the bottom rail or panel.

### 5 Build From

Specify where the selected railing or fencing should **Build From**. With the exception of Follow Stairs, these settings are not available for Solid railings.

- Check **Step Terrain** to have the railing or fencing follow the terrain in horizontal steps between each newel post. Not available if the selected railing is a Pony Wall.
- Check **Follow Terrain** to have the railing or fencing follow the terrain smoothly. Not available if the selected railing is a Solid or a Pony Wall.
- Check **Generate on Low Platform** to build the selected railing on the lower floor platform when the railing defines two room areas with different floor heights. See [Aligning Railings on Different Platforms on page 377](#).
- Check **Follow Stairs** to have the railing or fencing follow the rise of stairs drawn in the same location. See [Inset or Middle Railing on page 767](#) for more information.



## 6 Preview

A preview of the selected railing or fence, including any doorways or gates inserted into it, displays on the right. See *Dialog Preview Panes on page 22*.

## NEWELS/BALUSTERS PANEL

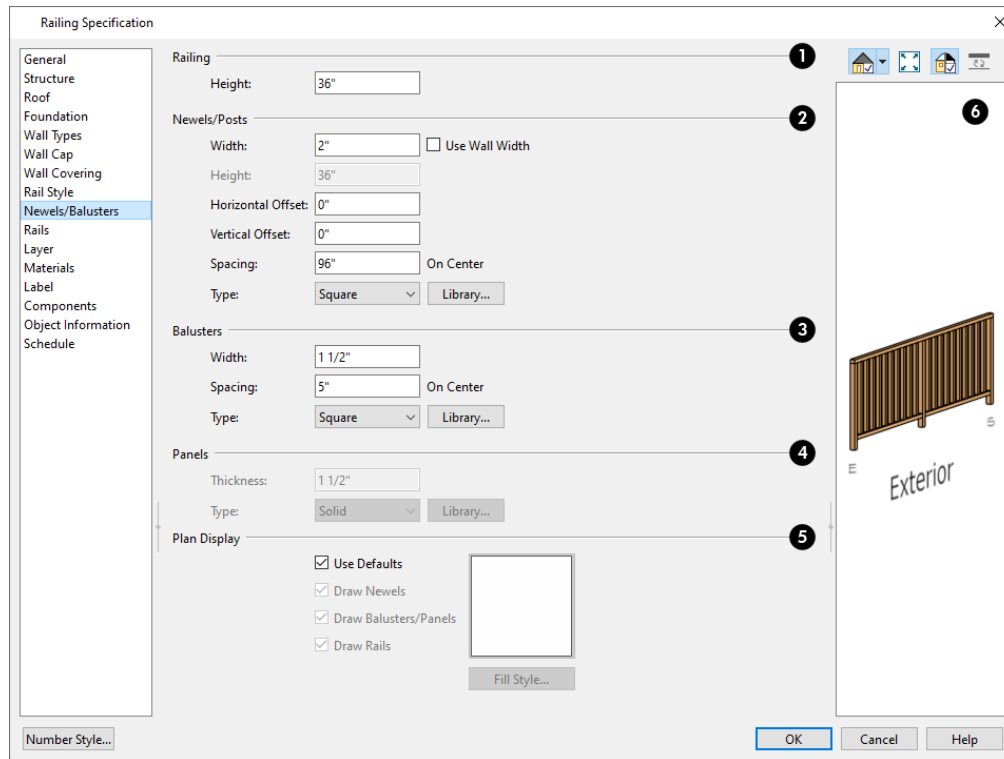

## 1 Railing

Specify the height of the railing, as well as its appearance in plan view.

- For interior railings, the **Railing Height** is measured from the height of the floor finish. See *Floor and Ceiling Platform Definitions on page 429*.

## 2 Newels/Posts

Specify the characteristics of the selected railing's newel posts.

- Specify the **Width** of each newel at its widest point.
- Check **Use Wall Width** to assign the width of the wall type assigned to the selected railing to its newels.
- Specify the **Height**, which is the height from the floor or ground to the top of the newel. Not available if Post to Rail, Post to Overhead Beam or Post to Ceiling is selected on the RAIL STYLE panel. See *Rail Style Panel on page 407*.
- Specify the **Horizontal Offset**, which is the amount each newel is offset from the center of the railing. You can use this setting to create a fence with the newels on one side of the fence boards.

- Specify the **Vertical Offset**, which is the amount each newel is raised or lowered. When this value is 0, the newels' bottom edges are positioned on the surface of the floor finish.
- Specify the on-center **Spacing** of the newel posts.
- **Type** - Select Square, Round, or Library newels.

Note: Selecting Library from the drop-down list is the same as clicking the Library button to the immediate right and allows you to select a symbol from the library. See [Select Library Object Dialog on page 974](#).

### 3 Balusters

These settings are only available when the railing type is “Balusters” on the RAIL STYLE panel.

- Specify the **Width** or diameter of each baluster at its widest point.
- Specify the on-center **Spacing** of the balusters.
- **Type** - Select Square, Round, or Library balusters.

### 4 Panels

These settings are only available when the railing type is specified as Panels on the RAIL STYLE panel.

- Specify the panel’s **Thickness**.
- Select “Solid” or “Library” from the **Panel Type** drop-down list.

 You can also apply newels, balusters, and panels onto a railing directly from the Library Browser. See [Inserted Objects on page 973](#).

### 5 Plan Display

These settings control how newels, balusters, and rails display in plan view. See [In Plan View on page 363](#).

- Uncheck **Use Defaults** to enable the settings that follow. When this is checked, the settings in the Defaults dialog for the tool used to draw the selected railing are used. This check box is also found in the Defaults dialogs for all wall tools except Railing: when checked, the defaults set in the Railing Defaults are used.
- Check **Draw Newels** to display newel posts in plan view.
- Check **Draw Balusters** to display balusters in plan view.
- Check **Draw Rails** to display the rails in plan view.
- Click the **Fill Style** button to open the Fill Style dialog and specify the fill style for newels, balusters, and/or rails, when set to display.

### 6 Preview

A preview of the selected railing or fence, including any doorways or gates inserted into it, displays on the right. See [Dialog Preview Panes on page 22](#).

## RAILS PANEL

The settings on the RAILS panel are used to specify the style and size of the horizontal components of a selected Railing, Deck Railing, or Fence. See [Railing and Deck Tools on page 349](#).

A similar panel is also found in the Staircase and Ramp Specification dialogs and has additional settings for handrails at walls. See [Rails Panel on page 783](#).

The settings on this panel are like those on the MOLDINGS panel found in a variety of dialogs in the program. See [Moldings / Profiles / Rails / Panels on page 927](#).

---

## Wall Hatching Specification Dialog



To open the Wall Hatching Specification dialog, select a Wall Hatching and click the **Open Object** edit button. The settings in this dialog are also found in the Wall Hatching Defaults dialog. See [Wall Hatching on page 357](#).

### LAYER PANEL

Specify the layer that the selected Wall Hatching is placed on. See [Layer Panel on page 186](#).

### FILL STYLE PANEL

The FILL STYLE panel is found in the specification dialogs for many different objects. See [Fill Style Panel and Dialogs on page 193](#).

### LABEL PANEL

Wall Hatching labels display in plan view when the "Walls, Labels" layer is turned on and use the Text Style assigned to that layer. The Automatic Label for wall hatching is blank, but you can specify a custom label. For information about the settings on this panel, see [Label Panel on page 700](#).

---

## Wall Schedules



The **Wall Schedule** tool allows you to produce customizable wall schedules or legends with information about wall types, wall assembly layers, length, and more. See [The Schedule Tools on page 682](#).

All wall types present in the current plan are listed in the Schedule Specification dialog. See [Wall Type Definitions on page 384](#).

When a new wall type is created, it will be included in any existing Wall Schedules as well as in the Wall Schedule Defaults automatically. See [General Panel on page 692](#).

A wall type that is not set to be included may still be listed in a Wall Schedule if it is part of a Pony Wall.

You can also specify which individual walls are included in a Wall Schedule in the Wall Specification dialog. This affects totals like Length and Count. If the wall in question is the only instance of its wall type, that wall type will not be listed even if it is set to be included in the Wall Schedule. See [General Panel on page 392](#).

An Invisible Wall will be included in a Wall Schedule provided that its wall type is set to be included and it has **Include in Schedule** checked.

# Rooms

## Chapter 12

Rooms are created when walls are drawn to enclose an area. When a room is defined in this way, it automatically receives both a floor and ceiling as well as features like moldings and finish materials that can be seen in 3D Views.

Rooms can be selected and edited. Each room can be assigned a Room Type with predefined characteristics. For example, a room defined as a Deck is assigned certain attributes that are different from a Kitchen.

### TOPICS

<b>Room Definition</b> .....	<b>413</b>
<b>Floor and Room Defaults</b> .....	<b>413</b>
<b>Room Types and Functions</b> .....	<b>415</b>
<b>Displaying Rooms</b> .....	<b>417</b>
<b>Selecting Rooms</b> .....	<b>418</b>
<b>Editing Rooms</b> .....	<b>419</b>
<b>Room Labels</b> .....	<b>422</b>
<b>Decks</b> .....	<b>425</b>
<b>Floor and Ceiling Heights</b> .....	<b>426</b>
<b>Floor and Ceiling Platforms</b> .....	<b>428</b>
<b>Tray and Coffered Ceilings</b> .....	<b>430</b>
<b>Tray Ceiling Specification Dialog</b> .....	<b>431</b>
<b>Special Ceilings</b> .....	<b>434</b>
<b>Room Moldings</b> .....	<b>436</b>
<b>Room Polylines</b> .....	<b>436</b>
<b>Room Specification Dialog</b> .....	<b>437</b>
<b>Room Finish Schedules</b> .....	<b>447</b>

---

## Room Definition

A room is a totally enclosed area defined by any combination of joined walls or railings, visible or invisible. To be recognized as a room by Chief Architect, a room must have an unbroken perimeter.

Unless otherwise specified, rooms generate floor and ceiling platforms automatically. Most rooms are also automatically covered by the roof when one is built. There are exceptions to this, such as rooms defined as Decks. See *Room Types and Functions on page 415*.

Room definition disappears if part or all of a surrounding wall is deleted. It is a good idea to finalize the position of walls before specifying Room Types or defining room attributes such as floor or ceiling height.

### SUBDIVIDING ROOMS

When a room area is first defined, it inherits its characteristics from the Floor Defaults dialog for that floor. If the room is then specified as a particular type, it may inherit properties from the Room Defaults dialog associated with its type. See *Floor and Room Defaults on page 413*.

If a new room is created by subdividing a larger room, it inherits its characteristics from that larger room - including any non-default settings.

If two rooms are separated by an Invisible wall, their interior areas will be measured from the wall's centerline and characteristics like the floor finish materials and moldings will break along that line.

- If the two rooms have different floor heights, the break will occur at the wall edge that faces the room where the floor is lower.
- If the two rooms have different ceiling heights, the break will occur at the wall edge that faces the room where the ceiling is higher.

### COPYING AND PASTING ROOMS

A room can be copied into the same or a different plan by copying and pasting the walls that define it. Rooms copied in this manner retain their size and shape, as well as any finish materials assigned to the walls. See *Copying and Pasting Objects on page 167*.

If you want to retain the room's Type and other specifications, copy and paste it and the walls that define it using the **Edit Area**  tools. See *Edit Area Tools on page 269*.

---

## Floor and Room Defaults

 Select **Edit> Default Settings** to open the Default Settings dialog, then click the arrow to the left of "Floors and Rooms" to expand the category. Here, you can access several defaults dialogs which directly affect rooms. Select a line item and click the **Edit** button to open the defaults dialog associated with it.

### FLOOR LEVEL DEFAULTS

Many important default values that affect rooms are specified in the Floor Defaults dialog for each floor in a plan. This dialog controls important information that the program uses to create a 3D model - particularly floor and ceiling heights and materials. Moldings can also be specified in the Floor Defaults dialog.

Only the defaults for Floor 1 can be set ahead of time. The program uses the settings from Floor 1 to create subsequent floors. Once a new floor is created, its floor defaults can be changed. See [Floor Defaults Dialog on page 731](#).



The Floor Defaults dialog for the current floor can also be opened by clicking the **Floor Defaults** button, which can be added to the toolbars. See [Adding and Removing Buttons on page 132](#).

## FLOOR 1 DEFAULT HEIGHT

Chief Architect always defines the default height of Floor 1 at 0'-0". This height value is measured from the top of the subfloor and is the constant by which the heights of structural elements in the program like walls, floors, and ceilings are measured. The heights of architectural objects can be measured relative to this absolute height, as well. As such, this default cannot be changed.

## FLOOR/CEILING PLATFORM DEFAULTS

**Floor** and **Ceiling Structure** and **Finish** definitions assigned to rooms have a hierarchy of dynamic defaults. See [Dynamic Defaults on page 79](#).

- The plan-wide defaults for platforms are set in the Floor/Ceiling Platform Defaults dialog.
- The plan-wide defaults can be overridden for each floor level in the Floor Defaults dialogs.
- Floor-wide platform defaults can be overridden in the Room Type Defaults dialogs.
- The platform defaults for Room Types can be overridden for individual rooms in the Room Specification dialog. See [Structure Panel on page 439](#).

See [Floor and Ceiling Platforms on page 428](#).

## ROOM TYPE DEFAULTS



The Room Types dialog can also be opened by clicking the **Room Types** button, which can be added to the toolbars.

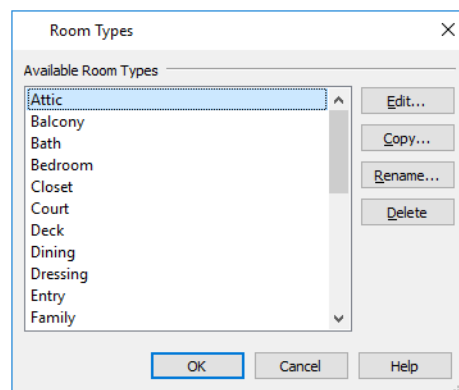

Select an **Available Room Type** from the list, then:

- Click the **Edit** button to modify the selected Room Type in the Room Type Defaults dialog.
- Click the **Copy** button to create a new Room Type based on the selected one, and customize it in the Room Type Defaults dialog to meet your needs.
- Click the **Rename** button to specify a new Name for the selected Room Type, which will affect its room label as well as how it is listed in room schedules.
- Click the **Delete** button to remove the selected Room Type from the list of those available in the plan.

The settings in the Room Type Defaults dialogs allow you to specify the following for each Room Type:

- The **Name**, as used in its default Room Label and in Room Schedules. See *Schedules and Object Labels on page 681*.
- The room **Function**. See *Room Types and Functions on page 415*.
- Inclusion in the **Living Area**. See *Living Area on page 424*.
- Inclusion in the **Conditioned Area**. See *Exported Envelope Data on page 1241*.
- **Ceiling Structure** and **Finish**. See *Floor and Ceiling Platforms on page 428*.
- **Floor Structure** and **Finish**.
- **Framing** and **Supports** for Deck rooms. See *Decks on page 425*.
- **Moldings**. See *Room Moldings on page 436*.
- **Components** information for use in the Materials List. See *Components Panel on page 1330*.

These settings are also found in the Room Specification dialog. See *General Panel on page 438*, *Structure Panel on page 439*, *Deck Panel on page 443*, and *Deck Support Panel on page 445*.

## ROOM LABEL DEFAULTS

The Room Label Defaults dialog allows you to specify the initial appearance of room labels. This dialog is also accessed by expanding the “Rooms” category in the Default Settings dialog. See *Room Labels on page 422*.

The options on most panels of the Room Label Defaults dialog are similar to those in the Text Specification dialog. See *Text Specification Dialog on page 506*.

The options on the DIMENSION FORMAT panel are similar to those in the Displayed Line Length dialog. See *Displayed Line Length Dialog on page 293*.

Any text added to the Room Label Defaults dialog displays in all subsequently created room labels, after the Room Name. Changes made to default settings do not alter existing room labels. To update existing labels so that they reflect changes made to the defaults, delete and replace them. See *Editing Room Labels on page 423*.

---

# Room Types and Functions

Room Types are used to quickly apply useful structural, functional, and appearance properties to different kinds of rooms. For example, a room assigned the “Garage” Room Type will receive concrete curbs under its walls when the Foundation is built, while a “Kitchen” will get GFCI Outlets when the Auto Place Outlet tool is used.

When a room is first created by enclosing an area with walls, it is assigned a generic room type of “Unspecified.” Once a room is created, though, it can be assigned a **Room Type** in the Room Specification dialog. See *General Panel on page 438*.

A selection of pre-defined Room Types is available for use; they are, however, editable; and, you can create your own, as well. See *Room Type Defaults on page 414*.

## ROOM TYPE DEFAULTS

Each Room Type is composed of two sets of characteristics: those set by the program, and those that are directly editable.

Characteristics set by the program are grouped together based on typical requirements for different types of rooms. These non-editable sets of properties is referred to as Room Functions.

Characteristics of a Room Type that can be modified include the default room Name, whether it is included in the Living Area and Conditioned Area, and the floor structure, finish, and deck supports. A default Function can also be specified. See *Room Type Defaults on page 414*.

When you specify that a room be a certain Room Type, all of the characteristics associated with that Room Type are assigned to the room, overriding existing settings. After you specify a Room Type, though, various settings can be customized.

## ROOM FUNCTIONS

A room Function is a set of non-editable characteristics that are typical of a certain type of room.

There are three broad categories of room Functions: Interior, Exterior and Hybrid.

- **Interior** - Most room Functions are Interior.
- **Exterior** - Balcony, Court, Deck.
- **Hybrid** - Attic, Garage, Open Below, Porch, Slab.

## EFFECTS OF ROOM FUNCTIONS

Chief Architect applies specific properties to rooms depending on the assigned Room Function.

### *Living and Conditioned Areas*

- All interior type rooms are included in Living Area calculations by default; exterior and hybrid type rooms are not.
- All interior type rooms are included in Conditioned Area calculations by default. Open Below rooms are also included; however, exterior and other hybrid type rooms are not. See [Exported Envelope Data on page 1241](#).

### *Ceilings and Roofs*

- Interior rooms have a flat ceiling and are set to generate a roof above them.
- Exterior rooms are assumed to be open to the outside and do not have a flat ceiling or generate a roof above them.
- Attic rooms do not receive a ceiling and are ignored by the program's automatic roof generator.
- Garage, Slabs, and Porches are treated like exterior rooms in all cases except that they generate a ceiling and a roof above them by default.

### *Floors and Foundations*

- A room's default floor structure and finish definitions are determined by its Room Type. See [Room Type Defaults on page 414](#).
- Open Below rooms have no floor platform and influence how adjacent walls are framed. Stairwells and Crawl Spaces are created using the Open Below Room Function.
- Garages have a foundation under them as defined by the Foundation Defaults dialog with a concrete slab at the top of stem wall or grade beam.
- The floor in Garage and Slab rooms display in 3D on Floor 0, not the first floor. See [Garages on page 716](#).
- Defining a room as Slab causes the floor platform thickness to equal the slab thickness value in the Foundation Defaults dialog.
- Deck rooms do not generate foundations. See [Decks on page 425](#).









### *Doors and Windows*

- A window placed in a wall between an exterior room and an interior room always faces out toward the exterior.
- Doors placed between interior and exterior type rooms inherit their settings from the Exterior Defaults for the door tool, if hinged or sliding; they display threshold lines and are considered Exterior. See [Interior vs Exterior Doors on page 544](#).
- Doors placed between interior type rooms do not display thresholds and are considered Interior.



- Open Below rooms are treated as interior rooms for window and door placement. All other hybrid type rooms are treated as interior.

### **Electrical**

- An electrical object placed on the wall of an exterior room using the **Light** , **Switch** , **110V Outlet**  or **220V Outlet**  tool will automatically be a waterproof or outdoor type fixture, as specified in the Electrical Defaults dialog. See [Electrical Defaults on page 667](#).
- The **Auto Place Outlets**  tool adds outlets automatically to all interior rooms. In Bath rooms, only one outlet over each sink is added. See [Auto Place Outlets on page 671](#).
- **Auto Place Outlets**  places GFCI outlets in Kitchens and Baths.
- **Auto Place Outlets**  places fewer outlets in hybrid type rooms.
- **Auto Place Outlets**  does not place outlets in exterior type rooms, Porches or Open Below rooms.

### **Dimensions**

- **Auto NKBA® Dimensions**  only generate in rooms specified as Kitchens or Baths. See [The Automatic Dimension Tools on page 472](#).

### **Plan Check**

- **Plan Check**  uses Room Functions and their characteristics for basic plan checking. For example, a closet does not need a smoke detector but a bedroom does. See [Plan Check on page 72](#).

---

## **Displaying Rooms**

Unlike most things in Chief Architect, a room is not an individual object. Rather, a room is a space defined by the walls that enclose it.

You can see the primary and secondary layers associated with a room by selecting it and clicking the **Object Layer Properties**  edit button. See [Object Layer Properties on page 187](#).

### **IN PLAN VIEWS**

Rooms typically display a transparent fill in plan view. You can, however, specify a solid color or fill pattern for all the rooms on an entire floor in the Floor Defaults dialog, or for individual rooms in the Room Specification dialog. See [Fill Style Panel on page 447](#).

In order for room fill styles to display, the “Rooms” layer must be turned on. See [Layer Attributes on page 177](#).

Room labels that include the room’s name as well as its size and other information can be set to display in plan view. See [Room Labels on page 422](#).

### **IN 3D VIEWS**

Rooms can be viewed in views created by any of the 3D view tools. The Floor Overview tool s can be used to see all rooms on the current floor without their ceilings. See [Creating Overviews on page 1087](#).

## IN THE MATERIALS LIST

 The contents of a room, including furnishings and floor and ceiling materials can be calculated using the **Calculate in Room** tool. See *Calculate Materials in Room on page 1304*.

The **Calculate Materials From Selection** edit tool creates a Materials List that calculates the finish materials in a selected room or rooms. Room moldings and wall, floor, and ceiling finish materials are counted, as is subflooring; but doors, windows, and structural materials like framing and other structural materials are not.

## IN SCHEDULES



 Information about rooms and their contents can be reported in different types of schedules. See *Room Finish Schedules on page 447*.

 You can also create any type of schedule that lists the contents of a selected room using the **Create Schedule from Room** edit tool. See *Create Schedule from Room on page 683*.

---

# Selecting Rooms

Room definition is established when a room is completely enclosed by walls. You can confirm that a room has room definition by using the **Select Objects**  tool to select it. When a fully-enclosed room is selected, its interior space becomes highlighted. See *Selecting Objects on page 210*.

Rooms can be group-selected using the Shift or Ctrl key. They can also be marquee-selected using the **Marquee Select Similar**  edit tool. To select rooms of a particular type, use the **Restrictive Selection**  option. See *Selecting Multiple Objects on page 213*.

Although rooms may be visible, if the “Rooms” layer is locked in the currently active layer set, it will not be possible to select a room. See *Locking Layers on page 178*.





Note: The selection color can be specified in the Preferences dialog. See *Colors Panel on page 98*.

As with many other objects in the program, rooms can be group-selected. Not all attributes of multiple selected rooms can be edited; however, many - such as moldings, materials, and fill style - can be.

## THE EXTERIOR ROOM

Each floor level of a plan has an Exterior Room, which allows you to control its exterior wall coverings and materials in the Exterior Room Specification dialog. See *Room Specification Dialog on page 437*.

To select the Exterior Room in plan view, click just outside an exterior wall using the **Select Objects**  tool. If a wall or other object becomes selected instead, click the **Select Next Object**  edit button or press the Tab key until the Exterior Room becomes selected. The Status Bar indicates which object is currently selected. See [The Status Bar on page 24](#).





When it is selected, a highlighted band around the plan's exterior displays.

### IN 3D VIEWS

A room can be selected in a 3D view by clicking on an empty space on its floor or a wall surface while the **Select Objects**  tool is active.

If you select a wall or other object instead of the room, click **Select Next Object**  edit button or press the Tab key until the room becomes selected.

In exterior camera views and overviews, the Exterior Room for each floor can be selected by clicking on the exterior surface of an exterior wall using the **Select Objects**  tool and then clicking the **Select Next Object**  edit button.

### SELECT ROOM BEFORE WALL IN 3D

By default, when you click on a wall surface in a 3D view, the individual wall will become selected. If you prefer to always select the room first instead of the wall, check **Select Room Before Wall in 3D** in the Preferences dialog. See [Architectural Panel on page 113](#).

### MATCH PROPERTIES

 Click a room to select it, then click the **Match Properties** edit button and group-select rooms with shared attributes. See [Match Properties on page 282](#).

---

## Editing Rooms

A room's structure and appearance can be modified using its edit tools and specification dialog. Rooms can be selected in all views, and the ways in which they can be edited depend somewhat on the current view. See [Selecting Rooms on page 418](#).

## IN 3D VIEWS

The top and bottom heights of individual walls, the floor and ceiling heights of individual rooms, and the floor and ceiling heights for entire floor levels can be edited using edit handles in 3D views. Lowered ceilings cannot be edited in 3D. See *3D Views on page 1079*. See *The Exterior Room on page 418*.

The default floor and ceiling heights for an entire floor level can be edited by selecting the Exterior Room. See *The Exterior Room on page 418* and *Floor and Room Defaults on page 413*.

### ***To change default ceiling heights in 3D***

1. Create a 3D or Cross Section/Elevation view of the exterior of your plan.
2. Click on the exterior surface of a wall, then click the **Select Next Object**  edit button.
3. When the Exterior Room is selected in 3D:
  - The wall that you clicked on remains highlighted and an edit handle displays along its top edge.
  - When the wall is on any floor other than Floor 1, an edit handle also displays along its bottom edge.
  - A bounding box displays around each wall of the selected floor level.
  - The Status Bar says “Exterior Room”. See *The Status Bar on page 24*.
  - A temporary dimension will display, measuring from the floor’s default rough floor to default rough ceiling. See *Temporary Dimensions on page 473*.
4. Click and drag the edit handle on the top wall edge to adjust the default ceiling height, or the edit handle on the bottom edge to adjust the default floor height.
5. As you drag a handle, notice that the entire floor level is affected.
  - The wall that you clicked on remains highlighted and an edit handle displays along its top edge.
  - When the wall is on any floor other than Floor 1, an edit handle also displays along its bottom edge.
  - A bounding box displays around each wall of the selected floor level.
  - The Status Bar says “Exterior Room”. See *The Status Bar on page 24*.
  - A temporary dimension will display, measuring from the floor’s default rough floor to default rough ceiling. See *Temporary Dimensions on page 473*.
6. Click and drag the edit handle on the top wall edge to adjust the default ceiling height, or the edit handle on the bottom edge to adjust the default floor height.

Note: Any rooms that do not update when the default floor or ceiling height is changed are not using the default values. To use the default values for a specific room, check Default for any of the room height values in its specification dialog. See *General Panel on page 438*.

### ***To adjust room heights in 3D***

1. Create a 3D or Cross Section/Elevation view of your plan.
2. Click on the surface of a wall that faces a room to select it, then click the **Select Next Object**  edit button.
3. When a room is selected in 3D:

- The wall that you clicked on remains highlighted and an edit handle displays along its top and bottom edges.
  - The Status Bar says “Room”.
  - A temporary dimension will display in cross section/elevation views, and measure from the room’s rough floor to rough ceiling.
4. Click and drag the edit handle on the top wall edge to adjust the room ceiling height, or the handle on the bottom edge to adjust its floor height. Temporary dimensions display.
  5. As you drag a handle, notice that all walls defining that room are affected.

### ***To adjust the height of a wall in 3D***

1. Create a 3D or cross section/elevation view of your plan.
2. Click on a surface of the wall to select it.
3. Click and drag the edit handles along its top and bottom surfaces. See [Wall Heights on page 371](#).



Room materials such as floor, ceiling, and wall materials can be changed in 3D views using the **Material Painter** . See [Material Painter Tools on page 1052](#).

Room moldings can be replaced directly from the library in 3D views, as well. See [Replace From Library on page 976](#).

 If you use the Material Painter to change a room’s floor or ceiling finish material, it will add that material to the room’s Floor or Ceiling Finish Definition. Changes to a Deck room’s planking or framing will affect its floor structure definition.

## **IN THE SPECIFICATION DIALOG**

 Floor and ceiling heights and structure, moldings, wall coverings, and materials can all be specified in the Room Specification dialog. See [Room Specification Dialog on page 437](#).

When multiple rooms are selected, the options available in the Room Specification dialog will be limited. You can, however, apply attributes to multiple rooms using the **Match Properties**  and **Apply Properties**  edit tools. See [Match Properties on page 282](#).

You can also apply a variety of attributes to rooms using **Style Palettes**. See [Style Palettes on page 279](#).

## **USING THE EDIT TOOLS**

A variety of options are available on the Edit Toolbar for a selected room. See [The Edit Toolbar on page 130](#).



**Calculate Materials for Room** creates a materials list of the contents of the selected room, not including walls. See [Calculate Materials in Room on page 1304](#).



**Turn Ceiling Off** removes the flat ceiling from the selected room while **Turn Ceiling On** restores it. See [Vaulted and Cathedral Ceilings on page 435](#).



**Add Selected Object(s) to Style Palette** adds the selected room’s attributes to a Style Palette. See [Style Palettes on page 279](#).



**Build Framing for Selected Object(s)** builds or rebuilds the framing for the selected room. See [Build Framing for Selected Object\(s\) on page 885](#).



**Make Room Polyline** creates a CAD polyline that follows the surfaces of the selected room. See [Room Polylines on page 436](#).



**Make Standard Area Polyline** creates a CAD polyline that follows the perimeter of the room's Standard area. See [Displaying Room Labels on page 423](#).



**Make Room Molding Polyline** creates a room molding polyline. See [Make Room Molding Polyline on page 436](#).



**Make Tray Ceiling in Room** creates a tray ceiling in the room. See [Tray and Coffered Ceilings on page 430](#).



**Expand Room Polyline** creates a temporarily enlarged room definition that ignores invisible walls and railings. See [Expand Room Polyline on page 437](#).



**Create Schedule from Room** creates a schedule showing only objects of a particular type located in that room. See [Create Schedule from Room on page 683](#).



**Create Room Elevation Views** creates an interior elevation view of each wall defining the selected room. See [Cross Section/Elevation Views on page 1089](#).



**Auto Room Dimensions** edit button to generate interior dimensions that measure each wall defining the selected room(s). See [Auto Room Dimensions on page 473](#).

---

## Room Labels

A label can display in plan view for any area defined as a room. There are two parts to each room label:

- The Room Name, which is set in the Room Specification dialog.
- The room size, which can be reported as dimensions and/or an area and is determined by the configuration of the walls that define the room.



Room labels can move or even disappear when room entries are revalidated.

### CUSTOM ROOM NAMES

The Room Names that display in room labels are based on the Room Types assigned in the Room Specification dialog. See [Room Types and Functions on page 415](#).

You can, however create a custom name for a selected room, also in the Room Specification dialog. See [General Panel on page 438](#).

Before creating a custom Room Name, assign the Room Type most similar to the room's actual use. For example, if you wish to name a room "Guest Room", begin by specifying it as a "Bedroom" since these rooms have similar uses.

You can assign a custom Room Name, move a room label or even delete it without affecting the Room Type.

### ROOM LABEL DEFAULTS



The initial settings that control the size, font, color and other aspects of room label appearance are controlled in the Room Label Defaults dialog. See [Room Label Defaults on page 415](#).

You can also add additional text to the default room label if you wish. This text will appear in the labels for all rooms.



Room labels can be customized using a variety of text macros. See [Text Macros on page 540](#).

## DISPLAYING ROOM LABELS

The display of room labels is controlled in the Layer Display Options dialog. By default, room labels are placed on the “Rooms, Labels” layer and use the Text Style assigned to that layer. See *Layer Display Options Dialog on page 179*.

You can specify how the area of rooms is reported by the program by turning on the display of one or more of these layers:

- **Rooms, Standard Area** is measured from the center of interior walls that define the room and from either the outside surface or the outside of the Main Layer of exterior walls, depending on the **Living Area to** setting in the General Plan Defaults dialog. It is rounded to the nearest square foot or mm and does not include the area within bay, box and bow windows. See *Exterior and Interior Walls on page 351* and *General Plan Defaults Dialog on page 92*.
- **Rooms, Interior Area** is measured from the inner surfaces of all the room's walls.
- **Rooms, Interior Dimensions** is also measured from the inner surfaces of the room walls. Its format is set on the DIMENSION FORMAT panel of the Room Label Defaults dialog. See *Room Label Defaults on page 415*.

The display of room labels can also be controlled on a room by room basis in the Room Specification dialog. See *General Panel on page 438*.

## EDITING ROOM LABELS

Room labels are similar to simple Text  objects and can be moved and resized much like any other text object. You can also modify a room label's Text Style and other attributes in the Room Label Specification dialog. See *Text Specification Dialog on page 506*.

The text of a room label cannot be modified in its specification dialog, however. The Room Name can only be specified in the Room Specification dialog and additional text can only be added in the Room Label Defaults dialog.

If you delete a room label, the Room Type and Room Name remain unchanged in the Room Specification dialog. To restore the label, check the **Show Room Label** check box on the GENERAL panel of that dialog.

If you wish to further customize an individual room's label by adding text or a text macro, uncheck **Show Room Label** in the Room Specification dialog and create your own label using a Text object. See *The Text Tools on page 497*.

Note: If you use the Convert to Rich Text edit tool to convert a Room Label to a Text object, it will no longer be display room size information or update if the room type is changed. See *Convert to Rich Text on page 512*.

## ROOM AREA

Unlike the rest of a room label, the room area and dimensions are not standard text entries and cannot be edited or changed. The room area moves, resizes and rotates with the rest of the room label, but you can turn the area and dimensions on or off separately in the Layer Display Options dialog. See *Displaying Rooms on page 417*.

All three area formats measure the room's size at floor level. The Interior Area room area calculation includes the areas within bay, box or bow windows, while the Standard Area and Interior Dimensions calculations do not.

You can use the **Make Room Area Polyline**  edit button to see the exact extents of the selected room's Standard Area.

You can also insert room areas as well as other information into text objects using Text Macros. See *Text Macros on page 540*.

## LIVING AREA

The Living Area label is an automatically generated Text object that reports the area of the current floor specified as living space. By default, interior type rooms are defined as part of the Living Area, while exterior and hybrid type rooms are not. In addition, rooms with a Rough Ceiling height that is less than 48" (1200 mm) are excluded from the Living Area by default. See [Room Functions on page 416](#).

Regardless of its Room Type, you can specify whether any room is included in the Living Area Calculation in the Room Specification dialog. See [General Panel on page 438](#).

A Living Area label is created as soon as a room area is defined by walls and/or railings and is recalculated every time you add, remove, resize, or redefine a room or when you **Rebuild Walls/Floors/Ceilings** . If multiple buildings are created, each will have its own Living Area label. If none of a structure's rooms are included in the Living Area Calculation, however, no Living Area label will display for it.

Each Living Area label can be edited in its specification dialog. Bear in mind, though, that if a new floor is added, any existing Living Area labels will be deleted and replaced. See [Text Specification Dialog on page 506](#).

Living Area labels are placed on the "Room Labels" layer by default. To turn off the display of all Living Area labels in a plan without affecting individual room labels, you can uncheck **Show Living Area Label** in the General Plan Defaults dialog. See [General Plan Defaults Dialog on page 92](#).

Living Area labels cannot be deleted: if you select one and click the **Delete**  edit button, **Show Living Area Label** in the General Plan Defaults dialog will become unchecked.

## LIVING AREA VS. FOOTPRINT

The Living Area should not be mistaken for the footprint of a house. Only true livable areas are included in the Living Area calculation. By default, exterior and hybrid room types such as Garage, Deck, and Porch are not included. Neither is any room labeled Open Below or Attic. See [Room Functions on page 416](#).

Regardless of its room type, you can specify whether a room is included in the Living Area calculation in the Room Specification dialog. See [General Panel on page 438](#).

 You can quickly see which rooms are included in the Living Area using the Match Properties edit tool. See [Matching Properties on page 282](#).

Living Area is measured from either the outside surface or the outer surface of the Main Layer of exterior walls. See [Wall Type Definitions on page 384](#).

You can use the **Make Living Area Polyline**  edit button to see the exact extents of the current Living Area Calculation.

### ***To find the extents of the Living Area***

1. Click just outside an exterior wall to select the current floor's Exterior Room. See [The Exterior Room on page 418](#).
2. Click the **Make Living Area Polyline**  edit button. This creates a polyline surrounding the area included in the Living Area on the current floor.
3. You can edit the polyline's shape to include or exclude portions of the plan if you wish. See [Using the Edit Toolbar on page 230](#).





Note: Editing the shape of the Living Area Polyline does not affect the Living Area Calculation.

4. Select the polyline and click the **Open Object**  edit button. The polyline's Area is stated in the Polyline Specification dialog. See *Polyline Panel on page 317*.

A polyline created using the **Make Living Area Polyline**  edit tool is a static representation of the current Living Area Calculation. If changes are made to the model that affect the Living Area, any previously created Living Area Polyline will not be affected.

### *To find the footprint of a floor*

1. Select the Exterior Room.
2. Click the **Make Room Polyline**  edit button. This creates a polyline around the exterior walls.
3. Edit the shape of the polyline if you wish.
4. Select the polyline and click the **Open Object**  edit button. The polyline's Area is stated in the Polyline Specification dialog.

## Decks

A Deck room is an exterior-type room that uses deck planking and framing to create a floor platform rather than using a floor finish that spans the entire room area. See *Floor and Ceiling Platform Definitions on page 429*.

The default settings for deck planking and framing are set in the Deck Room Defaults dialog. See *Room Type Defaults on page 414*.

To draw a deck, select **Build> Railing and Deck> Straight Deck Railing** , then click and drag to draw a railing. Once room definition is established, the area defined by the railing can be assigned the “Deck” room type.

- To create a deck without a railing, use one of the **Deck Edge** tools. See *Fencing Tools on page 351*.
- You can also create a regular, polygon-shaped deck using the **Polygon Shaped Deck**  tool. See *Polygon Shaped Deck on page 350*.

A room does not have to be defined by Deck Railing to be specified as a “Deck.” See *Room Types and Functions on page 415*. You can also define a room as a “Deck” in the Room Specification dialog. See *General Panel on page 438*.

By default, decks do not have roofs. If you want a roof over a deck, check **Roof Over This Room** in the Room Specification dialog. See *Structure Panel on page 439*.

To give the roof a visible means of support, you can select the **Post to Beam** option in the Wall Specification dialog. See *Rail Style Panel on page 407*.

Openings in deck railings can be created using **Doorways** . See *Openings in Railings on page 556*.

### DECK FRAMING AND PLANKING

When a Deck room is created, the floor platform is modeled using joists, beams, posts, and planking as specified in the Deck Room Defaults dialog. See *Structure Panel on page 439*, *Deck Panel on page 443*, and *Deck Support Panel on page 445*.

- If a floor level is present below the one that the Deck room is created on, the framing will be created there. If needed, beams may be generated with posts beneath them, if specified. When terrain is present, the posts will have footings, again, if specified.
- If a floor level is not present below the Deck, framing will be generated on the same floor as the room. Beams may be created but posts will not.
- Deck framing, planking, posts, and beams are placed on their own layers with names that begin with “Framing, Deck”: for example, “Framing, Deck Posts”. These layers are often turned off in plan view but are typically turned on in 3D views. See [Displaying Framing on page 879](#).

If standard floor framing is present when a room is specified as a Deck, that framing is deleted and replaced with deck framing.

If changes are later made to the settings on the DECK panel of the Room Specification dialog, the deck framing and planking will be automatically rebuilt in response. To prevent this from happening, uncheck **Automatic Deck Framing**.

Once created, the individual planking and framing objects generated for a Deck room can be selected and edited like other framing objects, provided that **Automatic Deck Framing** is turned off. See [Editing Framing on page 882](#).

To rebuild a deck’s framing and remove any changes you may have made to individual deck framing or planks, select the Deck room and click the **Build Deck Framing**  edit button.

If you delete a Deck room, its deck framing and planking will be automatically deleted, as well. To prevent this from happening, check **Keep Deck Framing After Deck Room is Deleted**. See [Deck Panel on page 443](#).

The structural materials for a selected deck can be calculated in a Materials List by clicking the **Calculate Structural Materials for Deck** edit button. See [Materials Lists on page 1303](#).

## DECK FRAMING SCHEDULES

The framing components that make up the decks in a plan can be listed in a Framing Schedule. See [Framing Schedules on page 882](#).

---

# Floor and Ceiling Heights

Default floor and ceiling heights are defined in the Floor Defaults dialog for each floor, including the foundation. Use the Floor Defaults dialog to change these values on a floor-by-floor basis. See [Floor and Room Defaults on page 413](#).

Use the Room Specification dialog to set floor heights on a room-by-room basis. See [Room Specification Dialog on page 437](#).

Different rooms on the same floor can have unique floor and ceiling heights, allowing you to create:

- Split levels and bi-levels
- Sunken living rooms and garages
- Cathedral, vaulted, and coffered ceilings.



In 3D views, you can adjust the default floor and ceiling height for the entire floor, the floor and ceiling height for an individual room, or the top and bottom heights of an individual wall. See [In 3D Views on page 420](#).

In order to raise or lower an area's floor or ceiling height, you must give it a room definition. To create room definition without enclosing an area with solid walls, use **Railings** .

Invisible walls and railings will fill in the vertical space between floor platforms of different heights as long as **Generate Between Platforms** is checked in their specification dialog. See [General Panel on page 392](#).

Ceiling and floor heights are interrelated. Changing the floor height in one room can affect ceiling heights of the rooms below.

- If a room's floor is lowered, its ceiling height is increased while the ceiling below that room drops.
- If the floor is raised, the ceiling height decreases while the ceiling below that room is raised.

If the rooms above a particular room have more than one floor height, the room's ceiling is stepped.

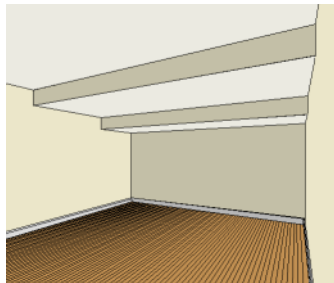

In a situation like this, a Lowered Ceiling can be used to cover "steps" made by different floor heights on the floor above. See [General Panel on page 438](#).

## DROPPED CEILINGS AND RAISED FLOORS

The structure of a dropped, or suspended, ceiling can be specified in the Ceiling Finish Definition dialog either for a room or the defaults for a floor. See [Floor and Ceiling Platform Definitions on page 429](#).

### **To create a framed dropped ceiling**

1. Select a room and click the **Open Object**  edit button.
2. On the STRUCTURE panel of the Room Specification dialog, click the **Ceiling Finish** button. See [Structure Panel on page 439](#).

3. In the **Ceiling Finish Definition** dialog:

- Specify Layer 1 as the plenum, or air gap, space.
- Specify Layer 2 as the horizontal framing. Framing member spacing and width are set in the material definition. See [Define Material Dialog on page 1066](#).
- Specify Layer 3 as the drywall.
- Specify Layer 4 as the paint color.

A dropped ceiling composed of a metal grid requires only two layers: one for the plenum and one for the tiles.

You can create a raised floor, such as for a shower pan, in a similar manner by specifying it in the Floor Finish Definition dialog.

## SHELF CEILINGS

In rooms with high or vaulted ceilings, it is possible to have a smaller room such as a closet that has a flat, lower ceiling. By default, the area above the flat ceiling will be enclosed by automatically-generated Attic walls. See [Attic Walls on page 380](#).

If you prefer, you can specify that these Attic walls be suppressed and an open space be created instead. This condition is referred to as a **Shelf Ceiling**, or plant shelf, and can be specified in the Room Specification dialog of the room with the lower flat ceiling. See [Structure Panel on page 439](#).

## SPLIT LEVELS

A split level can be created by raising or lowering the floor and ceiling heights of various areas of the plan.

In the following example, the lowest floor height is 0, the next is 24, and the next is 48 inches. The ceiling height in each room is set at 109 inches. See [Split Levels on page 736](#).

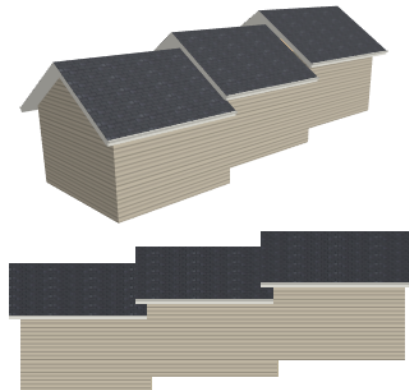

---

# Floor and Ceiling Platforms

In many ways, rooms in Chief Architect are defined by the floor platforms below them and the floor and/or ceiling platforms above.

All floor and ceiling platform and finish materials are used for the calculation of the materials list. See [Materials Lists on page 1303](#).

## FLOOR VS CEILING PLATFORMS

Floor and ceiling platforms are not the same thing in Chief Architect. Floor platforms have living space above them and are designed to be weight-bearing. Ceiling platforms, on the other hand, have living space below them but not above them. They are not designed to bear weight and are typically less strong - and less thick - than floor platforms.

## FLOOR AND CEILING PLATFORM DEFINITIONS

Floor and ceiling platforms are made up of layers of different materials such as framing, subflooring or drywall, and finish materials. So, typically, are Floor Material Regions. See [Floor and Wall Material Regions on page 1037](#).

Floor and ceiling platform definitions play a role in determining floor and ceiling heights. Floor and ceiling finishes can be used to create raised floors as well as dropped ceilings. See [Floor and Ceiling Heights on page 426](#).

- You can specify the composition of the default floor and ceiling platforms for an entire plan in the Floor/Ceiling Platform Defaults dialog. The settings in this dialog are also found in the Room Specification dialog. See [Structure Panel on page 439](#).
- Floor and ceiling platforms can be customized on a floor-by-floor basis in the Floor Defaults dialog. See [Floor Level Defaults on page 413](#).
- Floor and ceiling platforms can also be customized for individual rooms in the Room Specification dialog. See [Structure Panel on page 439](#).

Regardless of how they are accessed, floor and ceiling structure are defined in the Floor and Ceiling Structure Definition dialogs. See [Material Layers Definition Dialogs on page 1040](#).

Note: Subflooring refers to the topmost layer(s) of a floor structure not specified as Framing.

In addition to the structural layers of a platform, floors and ceilings typically have one or more finish layers. You can specify floor and ceiling finish materials for an entire floor or individual room much the way you can structural layers: by clicking the **Floor Finish** and/or **Ceiling Finish** button on the STRUCTURE panel of either the Floor Defaults or Room Specification dialog to open the Floor or Ceiling Finish Definition dialog.

## FLOOR AND CEILING FINISHES AND THE MATERIAL PAINTER

 If you use the **Material Painter** to change a room's floor or ceiling finish material, it will add that material to the room's Floor or Ceiling Finish Definition. Changes to a Deck room's planking or framing will affect its Floor Structure Definition. See [Material Painter Tools on page 1052](#).

When the Material Painter is used to add a floor or ceiling finish material in a room where one does not currently exist, a new finish layer is created and the material Depth is used as its Thickness. See [Materials List Panel on page 1075](#).

## FLOOR MATERIAL REGIONS

 **Floor Material Regions** allow you to create areas within a floor that use different layers of materials than the parent object. See [Floor and Wall Material Regions on page 1037](#).

## STEPPED FLOOR AND CEILING PLATFORMS

Each floor has default floor and ceiling heights. You can, however, use the Room Specification dialog to specify floor and ceiling heights on a room by room basis to create stepped floors and ceilings. See [Structure Panel on page 439](#).

If you require a single floor platform with a uniform height and thickness but different ceiling heights for the rooms below, specify a lowered ceiling using the Ceiling Finish Specification dialog. See [Lowered Ceilings on page 434](#).

Either way, by default, any gap between floor and ceiling platforms that step at a railing or invisible wall is closed off by a short section of solid wall. If you require a gap between the platforms, either select a single-layer wall type or uncheck **Generate Between Platforms** in the Wall or Railing Specification dialog. See [General Panel on page 392](#).

## PLATFORM EDGES

Typically, floor and ceiling platforms are built so that they bear on top of walls. The edges of the platform structures extend through exterior walls to the layer of the wall type definition with the **Build Platform to This Line** setting. See [Wall Type Definitions on page 384](#).

- For framed walls, the **Build Platform to This Line** layer is set as the outside of the wall's Main Layer,
- For concrete walls, it's the inside of the wall's Main Layer.
- The platforms of rooms with raised floors and/or lowered ceilings build in the same manner: to the **Build Platform to This Line** layer of the wall type assigned to the railing or invisible wall defining the room. See [Floor and Ceiling Heights on page 426](#).

For a given wall type, you can specify a different **Build Platform to This Line** wall layer surface provided that it is on the exterior side of the Main Layer.

In addition, you can specify that individual walls build through floor and ceiling platforms in the Wall Specification dialog. See [General Panel on page 392](#).

## PLATFORM HOLES



Select **Build> Floor> Hole in Floor Platform** or **Hole in Ceiling Platform**, then click and drag a rectangular polyline that forms a hole in the designated platform.

You can also create a hole in a floor or ceiling platform by drawing a closed CAD polyline and then using the **Convert Polyline**  edit button to convert it into a platform hole. See [Convert Polyline on page 262](#).

Platform hole edges derive their material from the ceiling finish of the room directly below the hole.

Note: The Hole in Ceiling Platform tool only forms holes in the flat ceiling that is automatically generated in a room. It does not create holes in manually drawn Ceiling Planes. See [Ceiling Planes on page 826](#).

---

## Tray and Coffered Ceilings

A wide variety of different tray and coffered ceiling configurations can be created using Tray Ceiling Polylines. A basic Tray Ceiling Polyline is made up of an upper and lower Ceiling Plane and a ceiling plane hole, but you can add moldings and rope lights if you wish. You can also add sloped sides formed by additional Ceiling Planes, and you can recess the tray ceiling into the ceiling platform rather than build it below the room's ceiling.

In addition to placing a single Tray Ceiling Polyline, smaller polylines can be nested inside larger ones and you can replicate nested polylines to create a coffered ceiling. See [Multiple Copy on page 172](#).

There are four ways to create Tray Ceiling Polylines:



Select **Build> Roof> Tray Ceiling Polyline** and then click inside a room. A Tray Ceiling Polyline that follows the shape of the room is created. Tray Ceiling Polylines can also be created by clicking and dragging. See [Polylines on page 316](#).



Create a Tray Ceiling Polyline that follows the perimeter of a room by selecting that room and clicking the **Make Tray Ceiling in Room** edit button.



You can also convert a closed CAD polyline into a Tray Ceiling Polyline. See [Convert Polyline on page 262](#).



In addition, you can select a Tray Ceiling Polyline and create a new, smaller one that follows the perimeter of the original by clicking the **Make Nested Tray Ceiling** edit button.

In order for a Tray Ceiling Polyline to generate in 3D, it must be located in a room with a flat ceiling. Tray Ceiling Polylines do not have surfaces on their sides, so while one can be positioned next to a room with no ceiling, it will not have a closed side. See [Structure Panel on page 439](#).

If a Tray Ceiling Polyline is shaped or positioned in a way that is not supported, a Caution  symbol will display in its interior. In this state, the tray ceiling will not generate framing or display in 3D views. Move the mouse pointer over the symbol to display a Tool Tip with information about how to fix the problem.

## EDITING TRAY CEILING POLYLINES

Once created, Tray Ceiling Polylines can be edited much the way other closed CAD polylines are. See [Editing Closed Polyline-Based Objects on page 228](#).



Tray Ceiling Polylines can also be edited in their specification dialogs. See [Tray Ceiling Specification Dialog on page 431](#).



To generate framing for a selected Tray Ceiling Polyline, select it and click the **Build Framing for Selected Object** edit button. See [Build Framing for Selected Object\(s\) on page 885](#).

## EXPLODE TRAY CEILING



Click the **Explode Tray Ceiling** edit button to explode a selected Tray Ceiling Polyline into its component parts. The ceiling planes as well as the ceiling and/or platform hole and any Molding Polylines and Rope Lights can then be edited individually.

Once exploded, the components of a Tray Ceiling Polyline cannot be blocked together again.

This option is not available if the polyline displays a Caution  symbol.

---

# Tray Ceiling Specification Dialog



The Tray Ceiling Specification dialog opens if you select one more Tray Ceiling Polyline and click the **Open Object** edit button.

This dialog also opens when you select a room and click the **Make Tray Ceiling in Room** or **Make Nested Tray Ceiling** edit button. See [Tray and Coffered Ceilings on page 430](#).

The Tray Ceiling Specification dialog has the following panels:

## GENERAL PANEL

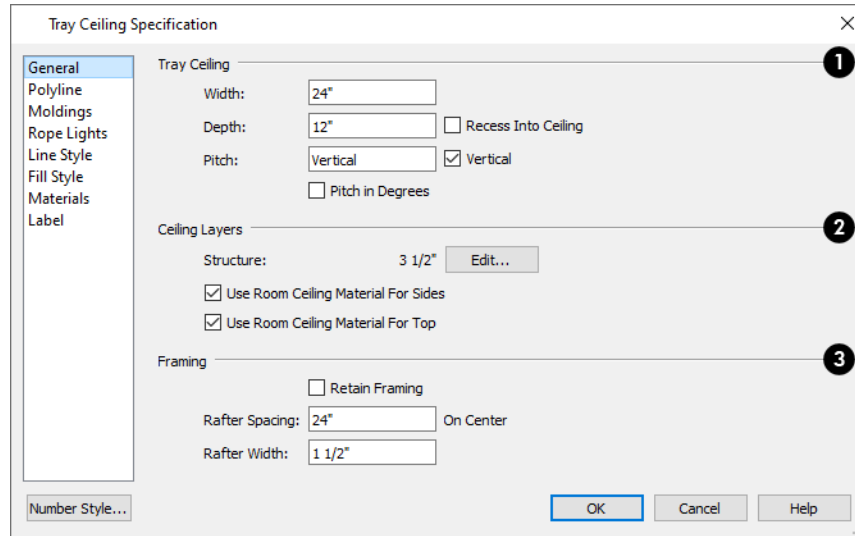

### 1 Tray Ceiling

Specify the tray ceiling's structure.

- Specify the **Width** of the outer ceiling, from the outside edge to the hole in its center. The Width setting is only present when this dialog is opened using the **Make Tray Ceiling in Room** or **Make Nested Tray Ceiling** edit tool.
- Specify the vertical **Depth**, which is the distance from the surface of the lower ceiling to that of the upper ceiling.
- Check **Recess into Ceiling** to build the outer ceiling at the room's specified ceiling height and raise the inner ceiling into the room's ceiling platform. When unchecked, the inner ceiling is positioned at the room's specified ceiling height and the outer ceiling is dropped.
- Specify the **Pitch** of the tray's sides. When a non-Vertical value is specified, a sloped Ceiling Plane is created along each edge. When this is the case, rope lights and moldings cannot be specified.
- Check **Vertical** to produce vertical sides with no side Ceiling Planes.
- Check **Pitch in Degrees** to display the pitch value in degrees in all dialogs as well as in roof plane labels. Values between  $-89^\circ$  and  $89^\circ$  can be entered. When this is unchecked, Pitch is described in terms of rise and run: x inches in 12 or in metric plans, x mm in 1000.

### 2 Ceiling Layers

- The total thickness of the **Structure** displays here for reference. Click the **Edit** button to modify the structure. See [Material Layers Definition Dialogs on page 1040](#).
- Check **Use Room Ceiling Material for Sides** to apply the room's ceiling finish material to the sides of the tray ceiling.
- Check **Use Room Ceiling Material for Top** to apply the room's ceiling finish material to the top of the tray ceiling.



### 3 Framing

- Check **Retain Framing** to prevent the framing associated with the selected Tray Ceiling Polyline from being rebuilt. See *Build Framing for Selected Object(s) on page 885*.
- Specify the Tray Ceiling's on-center **Rafter Spacing**.
- Specify the **Rafter Width**.

### POLYLINE PANEL

The POLYLINE panel indicates the length of the tray ceiling interior's **Perimeter** and its enclosed **Area**. See *Polyline Panel on page 317*.

### MOLDINGS PANEL

Crown or other moldings can be assigned to a Tray Ceiling Polyline on the MOLDINGS panel. Moldings are placed around the inside perimeter of the polyline at the specified height.

The settings on the MOLDINGS panel are similar to those found in other specification dialogs throughout the program. See *Moldings // Profiles / Rails / Panels on page 927*.

The settings on this panel are only available when the Pitch of the tray ceiling sides is set to "Vertical" on the GENERAL panel.

### ROPE LIGHTS PANEL

The settings on the ROPE LIGHTS panel allow you to assign rope lights to the inside perimeter of the selected Tray Ceiling Polyline. See *Rope Lights on page 669*.

The settings on this panel are similar to those on the MOLDINGS panel found in a variety of dialogs in the program. See *Moldings // Profiles / Rails / Panels on page 927*.

Two things about the ROPE LIGHTS panel are unique:

- No attributes of the rope light aside from its **Horizontal** and **Vertical Offset** can be specified here.
- Click the **Edit** button to open the Rope Light Specification dialog for the rope light selected in the table. See *Rope Light Specification Dialog on page 678*.

The settings on the ROPE LIGHTS panel are only available when the Pitch of the tray ceiling sides is set to "Vertical" on the GENERAL panel.

### LINE STYLE PANEL

For information about the settings on this panel, see *Line Style Panel on page 305*.

### FILL STYLE PANEL

The settings on the FILL STYLE panel affect the appearance of the selected polyline in plan view. For information about these settings, see *Fill Style Panel and Dialogs on page 193*.

### MATERIALS PANEL

The MATERIALS panel can be found in dialogs throughout the program. For information about the settings on this panel, see *Materials Panel on page 1055*.

## LABEL PANEL

Tray Ceiling Polyline labels display in plan views when the “Roofs, Labels” layer is turned on and use the Text Style assigned to that layer. The Automatic Label for Tray Ceiling Polylines is blank, but you can specify a custom label.

For information about the settings on this panel, see [Label Panel on page 700](#).

---

## Special Ceilings

By default, the program builds a flat ceiling platform on top the wall plates of a room. More varied and complex ceilings are made using settings in the Room Specification dialog and the **Ceiling Plane**  tool. Ceiling planes are drawn and can be edited much like roof planes. See [Ceiling Planes on page 826](#).

### LOWERED CEILINGS

If you require uniform top plate heights and a single floor platform with a uniform height and thickness but different ceiling heights for the rooms below, specify a lowered ceiling. You can define a lowered or dropped ceiling in a room without affecting the top height of the walls by specifying the lowered ceiling framing as a layer in the Ceiling Finish Definition. See [Floor and Ceiling Platforms on page 428](#).

In the following illustration, the default ceiling height for the entire first floor is 120", and the room on the right has a ceiling finish lowered to 96".

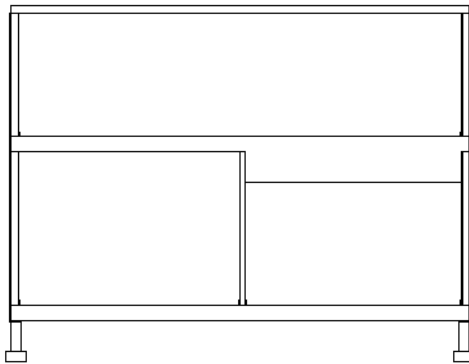

When a Soffit is positioned against the ceiling in a room, the Ceiling Finish layers located directly above it - including any lowered ceiling framing - will not generate. See [Placing Soffits on page 1033](#).

### ***To create a lowered ceiling***

1. Select the room in which you would like to specify a lowered ceiling.
2. Click the **Open Object**  edit button to open the Room Specification dialog.
3. On the STRUCTURE panel, click the **Ceiling Finish** button to open the Ceiling Finish Definition dialog. See [Material Layers Definition Dialogs on page 1040](#).
  - Select Layer 1 of the ceiling finish definition, then click the **Insert** button to create a new layer above the current Layer 1.
  - Specify the desired **Thickness** of the new layer, which will form the lowered ceiling framing.

- Click the **Select Material** button and specify the new layer's material as a Framing material.
  - Specify the **Structural Type**, the type of framing member you want to use to frame the lowered ceiling.
4. Repeat step 3 if you require additional layers, such as an air gap, above the lowered framing.
  5. When you are finished, click OK to close the Ceiling Finish Definition dialog.
  6. On the Structure panel, notice that the preview diagram represents the Finished Ceiling height (F).

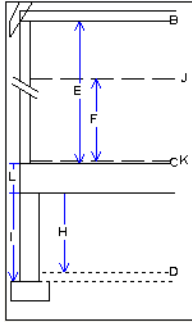



## VAULTED AND CATHEDRAL CEILINGS

A cathedral ceiling has the same pitch as the roof and is created using the underside of the roof above the room. A vaulted ceiling typically has a different pitch from that of the roof and is often framed using scissor trusses. See [Scissors Trusses on page 911](#).

### *To create a cathedral ceiling*

1. Build a roof for your plan. See [Roofs on page 791](#).
2. Select the room and open the Room Specification dialog. See [Room Specification Dialog on page 437](#).
3. On the STRUCTURE panel, uncheck **Flat Ceiling Over This Room**.

You can also remove or restore a selected room's flat ceiling by clicking the **Turn Off Ceiling**  or **Turn On Ceiling**  edit button.

By default, cathedrals ceiling use the ceiling material set in the Room Specification dialog. If you require a different material on a given roof plane, uncheck **Use Room Ceiling Finish** in the Roof Plane Specification dialog. See [Options Panel on page 817](#).

### *To create a vaulted ceiling*

1. To create a ceiling pitch different from the roof's, select **Build> Roof> Ceiling Plane**  and draw ceiling planes. See [Ceiling Planes on page 826](#).
2. Select each ceiling plane and specify its pitch. See [Ceiling Plane Specification Dialog on page 828](#).

## TRAY CEILINGS

A tray ceiling is an area within a ceiling that is raised and has either vertical or sloping sides. A variety of different tray and coffered ceiling configurations can be created using Tray Ceiling Polylines. See [Tray and Coffered Ceilings on page 430](#).

## CANTILEVER UNDERSIDES

Occasionally, a room will cantilever out past an exterior wall. You can specify the surface material of the underside of a cantilever on the MATERIALS panel of the Room Specification dialog. For no material, select "No Material" from the Plan

Materials dialog. See [Room Specification Dialog on page 437](#).

---

## Room Moldings

Base molding, chair rail, and crown moldings can be applied to rooms on a floor by floor basis in the Floor Defaults dialogs, to different room types in the Room Type Defaults dialogs, and to individual rooms in the Room Specification dialog. See [Floor and Room Defaults on page 413](#) and [Room Specification Dialog on page 437](#).

By default, Chief Architect does not automatically add room moldings to exterior or hybrid room types. Baseboards and chair rails are not automatically added to Open Below rooms, either; however, crown molding is if it is specified in the defaults for the room's floor. See [Room Types and Functions on page 415](#).

Base molding and chair rail heights are both offset from the floor, while crown molding is offset from the ceiling. For additional information, see [Moldings // Profiles / Rails / Panels on page 927](#).

By default, room moldings are suppressed behind cabinets placed against a wall. You can prevent this from occurring by checking **Suppress Adjacent Room Moldings** in the Cabinet Specification dialog. See [General Panel on page 644](#).

**Suppress Adjacent Room Moldings** is also an option in the Architectural Block Specification dialog as well as in the Symbol Object Specification dialog for fixtures and furniture. See [General Panel on page 1011](#) and [Symbol Object Specification Dialogs on page 986](#).

Room Moldings can be suppressed along an individual wall by checking **No Room Molding Exterior** and/or **Interior** in the Wall Specification dialog. See [General Panel on page 392](#).

Room Moldings can be converted into Molding Polylines that can be selected and edited as independent objects. See [Room Polylines on page 436](#).

---

## Room Polylines

Polylines for a variety of purposes can be created using the buttons on the Edit Toolbar for a selected room. See [Using the Edit Tools on page 421](#).

Once they are created, these polylines are not linked to the room in any way and are not affected if the room is altered.

### MAKE ROOM POLYLINE



Click the **Make Room Polyline** edit button to create a standard CAD polyline on the Current CAD Layer that follows the surfaces of the selected room. See [Current CAD Layer on page 326](#).

### MAKE STANDARD AREA POLYLINE



Click the **Make Standard Area Polyline** edit button to create a CAD polyline on the Current CAD Layer that follows the extents of the selected room's Standard Area. See [Room Area on page 423](#).

### MAKE ROOM MOLDING POLYLINE



To create a molding polyline that follows the interior surfaces of a room, select the room and click the **Make Room Molding Polyline** edit button.

If a Room Molding Polyline crosses a door or window, or a cabinet set to not cut room moldings, it will have a separate line segment at that location, with **No Molding on Selected Edge**. **No Molding on Selected Edge** will also be checked for any line segment associated with an Invisible wall or a wall that is set to have **No Room Molding**.

Room molding polylines can be edited just like other molding polylines. Their shape and height can be altered and the molding profile can be changed. Additional molding profiles can also be assigned. See [Molding Polylines on page 935](#).

## MAKE ROOM MOLDING POLYLINE DIALOG

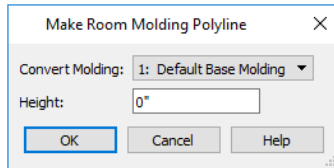

- From the **Convert Molding** drop-down list, select the molding profile that you would like to convert from a room molding to a molding polyline. The available options will be the molding profiles assigned to the selected room.
- Alternatively, select “Blank Molding” from the list to generate a molding polyline that follows the room perimeter and has separate edges with “No Molding” where it passes through door and window openings, but has no molding profile assigned to it.
- Specify the **Height** of the molding polyline being created, as measured from the selected room’s floor.

When you convert a base, crown, or chair rail molding to a molding polyline, that molding is removed from the room itself. See [Moldings Panel on page 446](#).

## MAKE TRAY CEILING IN ROOM

 Click the **Make Tray Ceiling in Room** edit button to create a Tray Ceiling Polyline that follows the shape of the selected room. See [Tray and Coffered Ceilings on page 430](#).

## EXPAND ROOM POLYLINE

 The **Expand Room Polyline** edit button is available when you select a room separated from other rooms by invisible walls or railings. Select this edit tool to create and select a temporarily enlarged room definition that ignores those invisible walls and railings. With this expanded room selected, you can then use one of the room polyline tools, create a Revision Cloud, or create a Materials List based on that selection.

### *To use the Expand Room Polyline tool*

1. Click in a room defined by at least one invisible wall or railing.
2. Click the **Expand Room Polyline**  edit button.
3. Click any of the edit buttons that remain available on the Edit Toolbar.

**Expand Room Polyline** does not create a new room and cannot be used in combination with the **Auto Room Dimensions**  edit tool.

---

## Room Specification Dialog

 The Room Specification dialog controls the structural characteristics and appearance of a selected room. To open the Room Specification dialog, select one or more rooms and click the **Open Object** edit button. See [Selecting Rooms on page 418](#).

Some of the panels in this dialog are also found in the Exterior Room Specification dialog as well as in the Floor, Floor/Ceiling Platform, and Room Type Defaults dialogs. See [Floor and Room Defaults on page 413](#).

The Room Specification dialog has the following panels:

Some values in this dialog are dynamic. A value with Default specified references the Floor Defaults dialog. To return a value to the default, replace the check mark. See [Dynamic Defaults on page 79](#).

The settings in this dialog are similar to those in the Floor Defaults dialog, but affect only the selected room. See [Floor Defaults Dialog on page 731](#).

If multiple rooms are selected, not all of the settings in this dialog will be available. See [Selecting Objects on page 210](#).

Many of the settings in this dialog can be included in a Room Finish Schedule. See [Schedules and Object Labels on page 681](#).

## GENERAL PANEL

The GENERAL panel is also available in the Room Type Defaults dialogs. See [Floor and Room Defaults on page 413](#).

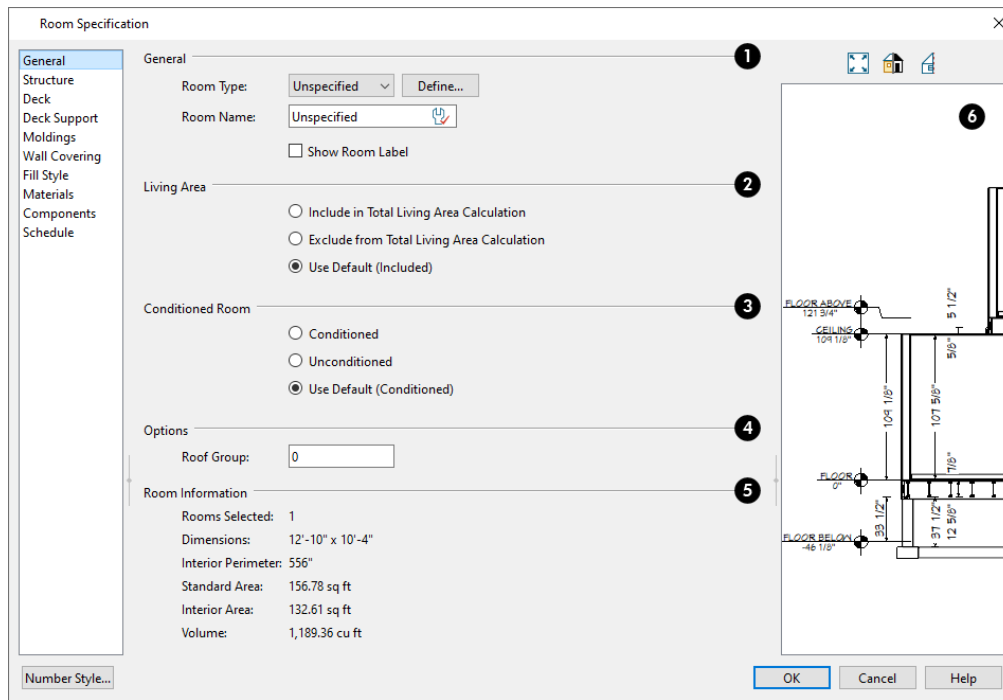

### 1 General

Specify the Room Type, the appearance of the Room Label, and how the room appears in the Room Finish Schedule.

- Select the **Room Type** from the drop-down list. Changing the Room Type can affect settings throughout the dialog. See [Room Types and Functions on page 415](#).
- Click the **Define** button to open the Room Types dialog where you can customize the settings of the selected Room Type.
- In the Room Type Defaults dialog only, specify the **Function** of the selected room type. See [Room Functions on page 416](#).
- If you wish to use a custom name in the room's label and in Room Schedules, type the desired **Room Name** in the text field.

- Check **Show Room Label** to display the room label in plan view. See [Room Labels on page 422](#). Show Room Label is unchecked automatically if you select “Unspecified” as the Room Type, and checked automatically if you select any other Room Type; however, you can turn this behavior off if you wish in the Preferences dialog. See [Architectural Panel on page 113](#).

## 2 Living Area

See [Living Area on page 424](#).

- Select **Include in Total Living Area Calculation** to include the room in the Living Area regardless of its Room Type.
- Select **Exclude from Total Living Area Calculation** exclude the room from the Living Area regardless of its Room Type.
- Select **Use Default for Room Type (Included/Excluded)** to base the selected room’s inclusion in the Living Area on its Room Type. The default for the selected Room Type is stated in parentheses.

## 3 Conditioned Room

Conditioned Area totals are included when data is exported to REScheck. See [Exported Envelope Data on page 1241](#).

- Select **Conditioned** to include the room in the Conditioned Area of the structure, regardless of its Room Type.
- Select **Unconditioned** exclude the room from the Conditioned Area, regardless of its Room Type.
- Select **Use Default for Room Type (Conditioned/Unconditioned)** to base the selected room’s inclusion in the Living Area on its Room Type. The default for the selected Room Type is stated in parentheses.

## 4 Options

- Specify the **Roof Group** of the selected room. Change this value to control how the program combines the selected room’s roof system with that of the rest of the building when automatic roofs are built. This value is nearly always left at zero. Not available in the Room Type Defaults dialogs. See [Roof Groups on page 795](#).

## 5 Room Information

Size information about the selected room or rooms is reported here for reference.

### Preview

The preview on the right side of this dialog features a cross section diagram showing the relationships between the room’s heights and platform thicknesses.

- If present, the floors above and below the selected room are also shown. The left side of the floor above is offset for clarity.
- The height and thickness values shown in this diagram are set on the [Structure Panel on page 439](#).

## STRUCTURE PANEL

Some settings on the STRUCTURE panel are also found in the Floor, Floor/Ceiling Platform, and Room Type Defaults dialogs.

In the Floor/Ceiling Platform and Room Type Defaults dialogs, only the **Floor** and **Ceiling** settings are available. See [Floor and Room Defaults on page 413](#).

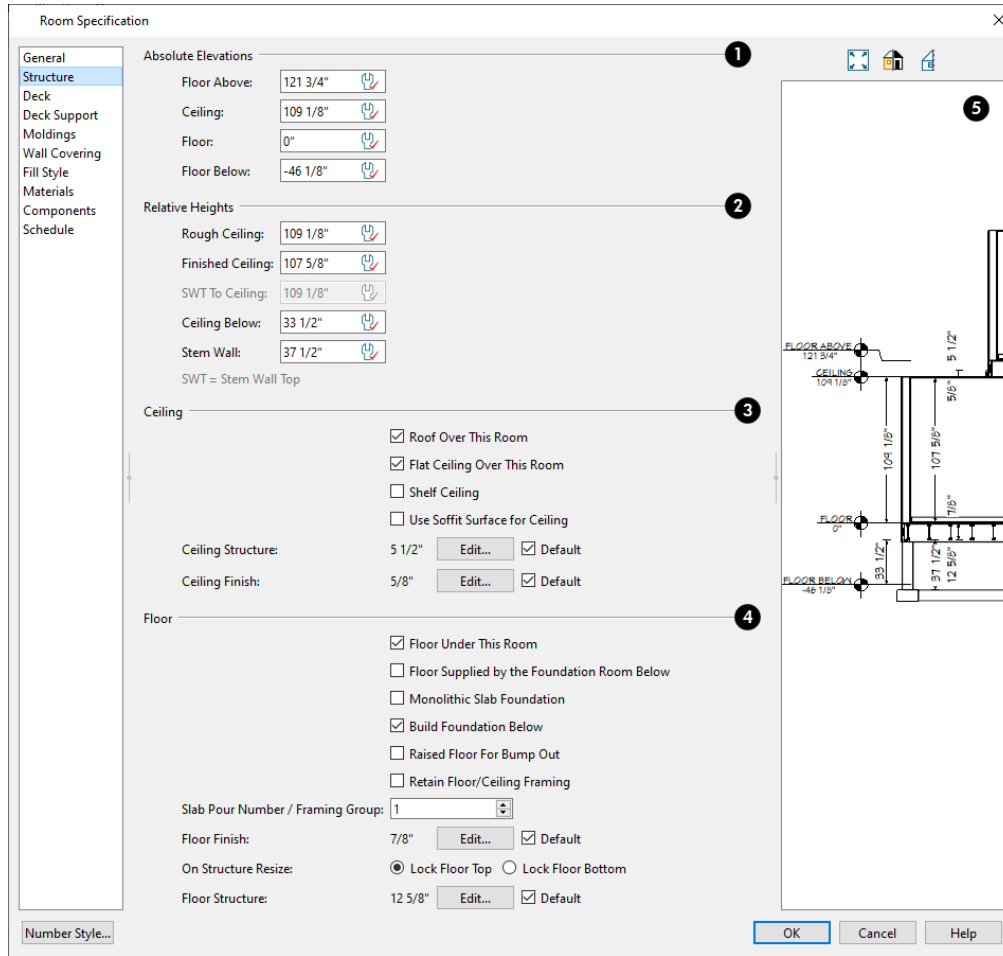

Active Defaults  icons in the Elevation and Height fields, as well as Default check boxes next to the Structure and Finish fields indicate that these settings are Dynamic Defaults. See [Dynamic Defaults on page 79](#).

Note: Many of the settings on this panel are interdependent. For example, if the Ceiling Structure thickness is modified, the Absolute Ceiling and Rough Ceiling heights will change in response.

### **1** Absolute Elevations

These height values are measured from zero, which is the default top height of the subflooring on Floor 1. See [Floor and Ceiling Heights on page 426](#).

- The **Floor Above** height displays here for reference. If multiple rooms with differing floor heights exist directly above, “No Change” will display.
- Specify the **Ceiling** height of the selected room, as measured from zero to the bottom of the ceiling framing. Not available in the Room or Floor Defaults dialog or if multiple floor heights are specified above the selected room.
- Specify the **Floor** height, as measured from zero to the top of the subfloor.

Note: The default floor height for Floor 1 is 0. It can be modified in the Room Specification dialog, but not in the Floor 1 Defaults dialog. See [Floor and Room Defaults on page 413](#).

- If a room is defined directly beneath the selected room on the floor below, additional settings may be available.



- Specify the **Floor Below** height, which is the subfloor height of the room directly below where you clicked to select the currently selected room. If there are multiple rooms with differing floor heights located below, this value may change depending on where you click.
- If the selected room is directly above a Garage and there is a foundation present, you can specify the **SWT Below** height, which is the top height of the concrete stem walls around the perimeter of the garage.

## 2 Relative Heights

These height values are measured from surfaces within the selected room or the room below.

- Specify the **Rough Ceiling** height, as measured from the subfloor surface to the bottom of the ceiling framing. Not available if multiple floor heights are specified directly above the selected room.
- Specify the **Finished Ceiling** height, as measured from the finished floor surface to the finished ceiling surface. Not available if multiple floor heights are specified directly above the selected room.
- Specify the distance from the **Stem Wall Top to Ceiling**. Only available when **Floor for this Room is Supplied by the Foundation 'Room' from the Floor Below** is checked, below.
- Specify the **Floor to Stem Wall Top** for rooms with **Floor for this Room is Supplied by the Foundation 'Room' from the Floor Below** specified.
- Specify the **Ceiling Below** height, which is the height of the ceiling of the room below, as measured from that room's subfloor to rough ceiling surfaces. Not available when Auto Rebuild Foundation is enabled or if there is no room below the selected room. See [Rebuilding Foundations on page 713](#).
- Specify the **Stem Wall** height, which is measured from the top of the foundation wall footing to the top of the treated sill plate, if one is specified. Only available if the selected room or the room below it is defined by foundation walls.

## 3 Ceiling

Only the Ceiling Finish and Structure settings are available in the Room Type Defaults dialogs.

- If **Roof Over This Room** is checked, a roof automatically generates over the room. If unchecked, no automatic roof generates.

If this option is unchecked and a roof plane is manually drawn over this room, its structure will be that of an eave rather than a regular roof. In most cases, if a roof is present over a room, this box should be checked. See [Roof Panel on page 869](#).

- If **Flat Ceiling Over This Room** is checked, the room has a flat ceiling. If unchecked, the ceiling follows the underside of the roof or manually drawn ceiling planes.
- Check **Shelf Ceiling** to prevent Attic Walls from generating over the interior walls that define the selected room. When unchecked, interior Attic Walls will generate if surrounding rooms have higher ceilings than the selected room. See [Shelf Ceilings on page 428](#).
- Check **Use Soffit Surface for Ceiling** to frame the roof over the selected room using the framing defaults for fascia rather than for rafters.
- The **Ceiling Structure** depth displays here for reference. Click the **Edit** button to open the Ceiling Structure Definition dialog and define the layers of materials that form the ceiling platform. Check **Default** to use the Ceiling Structure Definition set in the current floor's Floor Defaults dialog. Not available for rooms on Floor 0. See [Material Layers Definition Dialogs on page 1040](#).

- The **Ceiling Finish** depth displays here for reference. Click the **Edit** button to open the Ceiling Finish Definition dialog and define the layers of materials that form the finished ceiling surface. Check **Default** to use the Ceiling Finish Definition set in the current floor's Floor Defaults dialog. See *Material Layers Definition Dialogs on page 1040*.
- Check the **Default** box to the right of either button to restore the default structure and/or finish. See *Floor/Ceiling Platform Defaults on page 414*.

#### 4 Floor

Only the Floor Finish, Structure, and On Structure Resize settings are available in the Room Type Defaults dialogs.

- When **Floor Under This Room** is checked, the room has a floor platform as specified below.
- If **Floor Supplied by the Foundation Room Below** is checked, the floor platform for this room is a slab located on the floor below and cannot be edited here.
- If **Monolithic Slab Foundation** is checked, the current Floor Structure will be replaced by a single 4" (100 mm) layer of concrete with footings that can be seen in camera views only. When a stem wall or grade beam foundation is generated, a slab will be created beneath the selected room.



If the selected room has a living space located anywhere beneath it, avoid checking Monolithic Slab Foundation.

- When **Build Foundation Below** is checked, the selected room receives a foundation under it when the foundation is automatically built. Uncheck this box to prevent a foundation from being created below the selected room. See *Building a Foundation on page 710*.
- Check **Raised Floor For Bump Out** to allow a bump out room's floor and the ceiling of a room on the floor level below to build independently. When unchecked, the room below will use the bump out's floor platform as its ceiling. This box is checked by default for rooms created when a Bay/Box/Bow Window is exploded. See *Explode Bay/Bow Window on page 610*.
- Check **Retain Floor/Ceiling Framing** to preserve the selected room's floor and ceiling framing when floor and/or ceiling framing is globally rebuilt. See *Rebuilding and Retaining Framing on page 855*.
- When Monolithic Slab Foundation is checked, specify the room's **Slab Pour Number**. Pour Numbers are listed separately in the Materials List. See *In the Materials List on page 712*.
- When Monolithic Slab Foundation is unchecked, specify the selected room's **Framing Group** instead. See *Framing Groups on page 851*.
- The **Floor Finish** depth displays here for reference. Click the **Edit** button to open the Floor Finish Definition dialog and define the layers of materials that form the finished floor surface. Check **Default** to use the Floor Finish Definition set in the current floor's Floor Defaults dialog. See *Material Layers Definition Dialogs on page 1040*.
- Specify which part of the floor platform moves **On Structure Resize**. Select **Lock Floor Top** to keep the top of the floor structure at the same height and raise or lower its bottom when the platform depth is changed. Select **Lock Floor Bottom** to keep the bottom of the floor structure at the same height and raise or lower the top when the depth is changed.
- The **Floor Structure** depth displays here for reference. Click the **Edit** button to open the Floor Structure Definition dialog and define the layers of materials that form the floor platform. Check **Default** to use the Floor Structure Definition set in the current floor level's Floor Defaults dialog. See *Material Layers Definition Dialogs on page 1040*.

- If the selected room is a Deck, the Floor Structure button will be labeled **Planks, Joists** instead. See [Decks on page 425](#).
- Check the **Default** box to the right of either button to restore the default structure and/or finish. See [Floor/Ceiling Platform Defaults on page 414](#).

Note: The default floor and ceiling platform and finish definitions for rooms are set in the current floor's Floor Defaults dialog. In the Floor Defaults dialog, the defaults are drawn from the Floor/Ceiling Platform Defaults dialog. See [Floor and Room Defaults on page 413](#).

## 5 Preview

The preview on the right side of this dialog features a cross section diagram showing the relationships between the room's heights and platform thicknesses.

- If present, the floors above and below the selected room are also shown. The left side of the floor above is offset for clarity.
- The callout or dimension line associated with selected height or thickness value will be highlighted in the preview, as will any height or thickness value that you move your mouse point over.
- The font used by the callouts and dimensions is set in the currently active Dimension Defaults dialog, while the unit of measurement is specified in the Dialog Number/Angle Style dialog. See [Dimension Defaults Dialog on page 451](#) and [Dialog Number/Angle Style Dialog on page 126](#).
- What appears in both the diagram and in the settings on the STRUCTURE panel may be affected by the location where you clicked to select the room. For example:
- If the selected room is located above two rooms with different structural settings, the position of the pointer relative to these two lower rooms determines which of them displays as the floor below.
- If the selected room is located below two rooms with different floor heights, its absolute and relative ceiling height settings will be disabled.

## DECK PANEL

The options on the DECK panel are only available for rooms designated as Decks, and control how deck planking and joists are generated. See [Deck Framing and Planking on page 425](#).

The settings on this panel are also found in the Deck Room Defaults dialog, but affect the selected Deck room(s) only rather than Decks as they are initially created. See [Room Type Defaults on page 414](#).

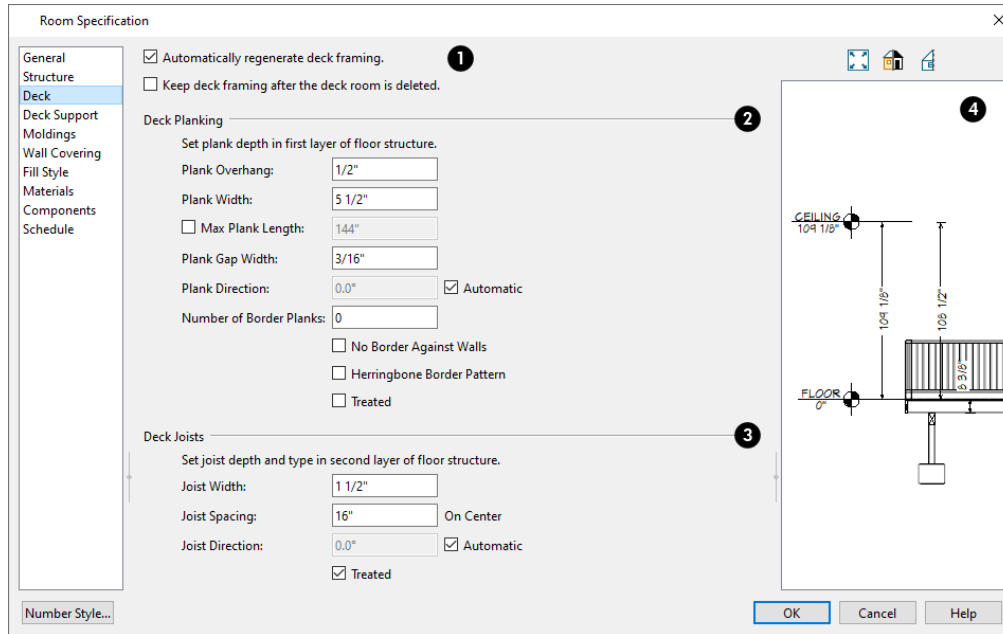

## 1 Automatic Deck Framing

- Check **Automatic Deck Framing** to generate planking and support framing for the deck that updates as changes are made to the deck. See *Decks on page 425*.
- Check **Keep Deck Framing After Deck Room is Deleted** to retain the automatically generated framing and planking when the selected deck room is deleted. When this box is unchecked, the framing is automatically removed if the room is deleted.

## 2 Deck Planking

- Specify how far the deck planking **Overhangs** the rim joists.
- Specify the **Plank Width** of the deck planking.
- Check **Max Plank Length**, then specify the maximum allowable length for the selected Deck's planks. When unchecked, planks run the full length of the Deck room.
- Specify the **Plank Gap Width**, which is the distance between individual planks.
- If you want to enter a **Plank Direction**, remove the check mark from **Automatic**. Enter the direction as degrees.
- Specify the **Number of Border Planks**. These are planks that follow the outside edge of the deck and may not be parallel with the rest of the planking. Border planks generate as long as the length of an inside edge is greater than 0". They do not generate on curved deck edges.

Note: Planking thickness and joist depth are specified in the Floor Structure Definition dialog. See *Floor and Ceiling Platform Definitions on page 429*.

- Check **No Border Against Walls** to prevent border planking from being generated along any walls defining the deck.

- Check **Herringbone** to produce a herringbone pattern where the border planks meet.
- Check **Treated** to specify that the deck planking is counted as treated in framing schedules and the Materials List.

### 3 Deck Joists

- Enter the **Width** of the joists that support the deck.
- Specify the **Spacing** between joists, as measured from joist center to joist center.
- If you want to specify joist **Direction**, uncheck **Automatic** and enter the direction in degrees. When checked, joists are run in the direction that results in the shortest spans.
- Check **Treated** to specify that the deck joists are counted as treated in framing schedules and the Materials List.

### 4 Preview

The preview on the right side of this dialog features a cross section diagram showing the relationships between the room's heights and platform thicknesses.

- If present, the floors above and below the selected room are also shown. The left side of the floor above is offset for clarity.
- The height and thickness values shown in this diagram are set on the *Structure Panel on page 439*.

## DECK SUPPORT PANEL

The options on the DECK SUPPORT panel are only available for Deck rooms and control how deck beams and posts are generated. See *Deck Framing and Planking on page 425*.

The settings on this panel are also found in the Deck Room Defaults dialog, but affect the selected Deck room(s) only rather than Decks as they are initially created. See *Room Type Defaults on page 414*.

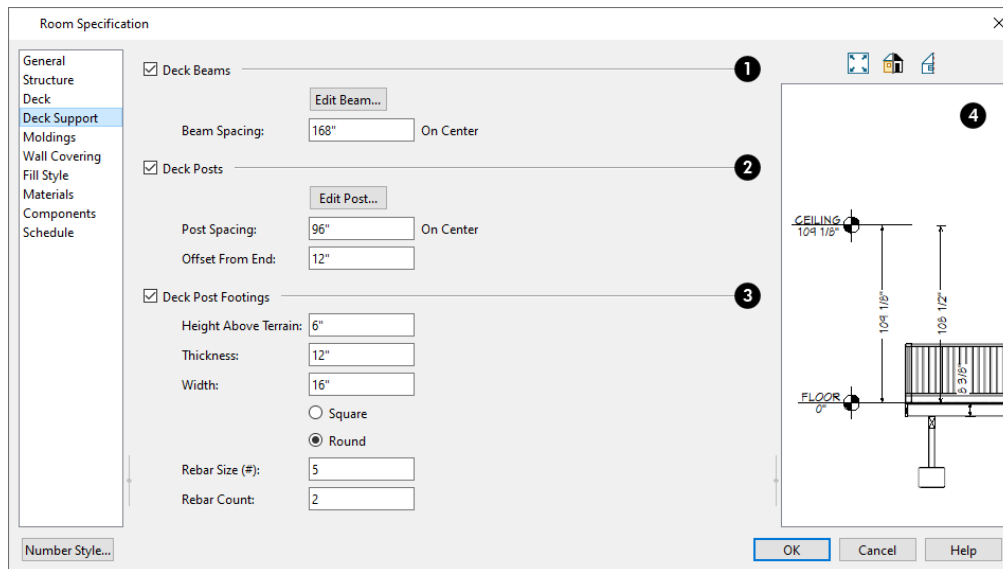

### 1 Deck Beams

Specify the configuration of the beams under the selected Deck room.

- Uncheck **Deck Beams** to prevent the automatic generation of support beams under the selected Deck room.
- Click the **Edit Beam** button to open the Deck Beam Defaults dialog and define the beam size and other characteristics. See *Framing Specification Dialog on page 887*.
- Specify the maximum on-center **Beam Spacing**. Beams may be positioned closer than this value, but not further apart.

## 2 Deck Posts

Specify the configuration of the posts under the selected Deck room.

- Uncheck **Deck Posts** to prevent the automatic generation of support posts under the selected Deck room.
- Click the **Edit Post** button to open the Deck Post Defaults dialog and define the size and other characteristics of the posts associated with the selected Deck. See *Framing Specification Dialog on page 887*.
- Specify the maximum **Post Spacing**. Posts may be positioned closer together than this value, but not further apart.
- Specify the **Offset from End**, which is the distance from the outermost beam to the edge of the deck platform. For railings directly over the outside of the beam, set this value to 0.

## 3 Deck Post Footings

These settings are not available if Deck Posts is unchecked, above.

- Uncheck **Deck Post Footings** to prevent the automatic generation of footings under the selected Deck room's posts.
- Specify the footings' **Height Above Terrain**. See *Foundations and the Terrain on page 717*.
- Specify the footings' **Thickness** and **Width**.
- Specify whether the footings are **Square** or **Round** in shape.
- Specify the **Rebar Size Number**.
- Specify the **Rebar Count**, or number of bars in each footing.

## 4 Preview

The preview on the right side of this dialog features a cross section diagram showing the relationships between the room's heights and platform thicknesses.

- If present, the floors above and below the selected room are also shown. The left side of the floor above is offset for clarity.
- The height and thickness values shown in this diagram are set on the *Structure Panel on page 439*.

## MOLDINGS PANEL

Chair rail, crown and base moldings can be assigned to one or more selected rooms on the MOLDINGS panel. Moldings are placed on a room's wall surfaces and continue around the surface of any soffit that is attached to the wall at the molding height.

The settings on this panel are also similar to those found in the Floor Defaults dialog, but affect only the selected room instead of all rooms on the current floor.

The settings on this panel are similar to those found in other specification dialogs throughout the program. See *Moldings // Profiles / Rails / Panels on page 927*.

## WALL COVERING PANEL

The settings on the WALL COVERING panel of the Room Specification dialog are the same as those on the same panel of the Wall Specification dialog. When a wall covering is assigned in the Room Specification dialog, it is applied to all walls in the selected room only. See *Wall Covering Panel on page 404*.

## FILL STYLE PANEL

The settings on the FILL STYLE panel affect the appearance of the room in plan view. This panel is also found in the Floor Defaults dialog. For more information, see *Fill Style Panel and Dialogs on page 193*.

## MATERIALS PANEL

The settings on this panel affect the appearance of a selected room's walls, floor, ceiling, and moldings in 3D views. See *Materials Panel on page 1055*.

The materials that make up the floor and ceiling platforms can be defined on the STRUCTURE panel. See *Structure Panel on page 439*.

Default molding and ceiling and floor covering materials can be set on this panel in the Floor Defaults and Room Defaults dialogs.

## COMPONENTS PANEL

The information on the COMPONENTS panel can be used in the materials list. For more information, see *Components Panel on page 1330*.

## SCHEDULE PANEL

The settings on the SCHEDULE panel determine which schedule categories the selected room is included in. See *Schedule Panel on page 704*.

---

# Room Finish Schedules



The **Room Finish Schedule** tool allows you to produce customizable room finish schedules with information about room size, structure, materials and moldings. Information about door and window trim can also be included. See *The Schedule Tools on page 682*.

By default, Room Finish Schedules are set to include all Room Types: including any new Room Types that you may create. You can specify which Room Types are included in a Room Finish Schedule in its Schedule Specification dialog. See *General Panel on page 692*.

Additional information about tray ceiling moldings and door and window trim can be included in any schedule set up to include items in the Molding category.



You can also create any type of schedule that lists the contents of a selected room using the **Create Schedule from Room** edit tool. See *Create Schedule from Room on page 683*.

# Dimensions

## Chapter 13

Chief Architect provides a variety of manual and automatic dimensioning tools for measuring walls, doors, windows, and many other objects in various 2D and 3D views.

Dimensions can be used to accurately position objects relative to other objects. In addition, dimension lines and extensions can be selected and customized.

### TOPICS

<b>Compatibility With Previous Versions</b> .....	<b>449</b>
<b>Dimension Preferences and Defaults</b> .....	<b>449</b>
<b>Dimension Defaults Dialog</b> .....	<b>451</b>
<b>Auto Story Pole Dimension Defaults Dialog</b> .....	<b>464</b>
<b>Temporary Dimension Defaults Dialog</b> .....	<b>467</b>
<b>The Manually Drawn Dimension Tools</b> .....	<b>469</b>
<b>The Automatic Dimension Tools</b> .....	<b>472</b>
<b>Displaying Dimension Lines</b> .....	<b>474</b>
<b>Selecting Dimension Lines</b> .....	<b>475</b>
<b>Editing Dimension Lines</b> .....	<b>476</b>
<b>Editing Extension Lines</b> .....	<b>478</b>
<b>Add Additional Text</b> .....	<b>482</b>
<b>Moving Objects Using Dimensions</b> .....	<b>483</b>
<b>Dimension Line Specification Dialog</b> .....	<b>485</b>



---

## Compatibility With Previous Versions

Dimensions function differently in Versions 9 and later of Chief Architect than they did in previous versions. Being familiar with these changes is helpful if you have plans that were originally created in these legacy program versions.

### EXTENSION LINES

In Chief Architect 8, extension lines had two modes: normal and short. Version 9 and later offer full control over extension lines. If **Legacy Compatible Extensions** is checked, you do not have this control. See [Extensions Panel on page 462](#).

### ACCURACY

When the model is drawn with greater accuracy than dimensions are set to display, rounding may be required. The **Rounding Method** in the Dimension Defaults dialog controls how Chief Architect handles dimensions that require rounding. See [General Panel on page 451](#).

In Chief Architect Version 8 and prior, dimensions used Distance Rounding, which shows the distance between equally spaced objects correctly, but dimension runs are not always accurate when added.

In Versions 9 and later, dimensions use Grid Rounding, which always add up dimension runs correctly, but individual distances may be inaccurate in order to achieve this.

Dimensioning the same object using these two rounding methods will obtain the same results as long as objects are placed with the same accuracy as the precision of the dimension lines. If an object is placed using more precision than the dimensions, results may vary between methods.

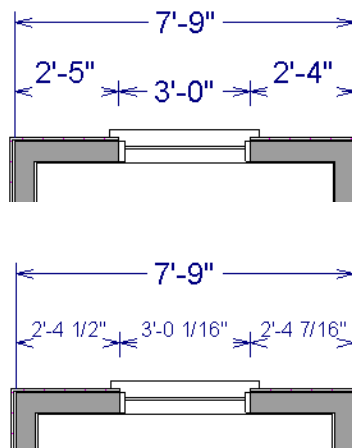

 A good approach to accurate dimensioning is to turn on the accuracy indicators and position objects so that the inaccuracy indicators do not display.

---

## Dimension Preferences and Defaults

There are a number of defaults settings as well as options in the Preferences dialog that affect dimensions.

## PREFERENCES



All plan and layout files save measurements in either U.S. or metric units. The type of unit used is determined when the file is first created and cannot be changed later. See [Creating a New Plan or Layout on page 38](#).



You can specify either metric files or those using U.S. Units to be used as the templates whenever you open a new, blank plan or layout file in the Preferences dialog. See [New Plans Panel on page 108](#).

You can also specify the minimum on-screen display size for dimension numbers in the Preferences dialog. See [Appearance Panel on page 95](#).

## DEFAULT SETTINGS



Select **Edit> Default Settings** to open the Default Settings dialog, then click the arrow next to "Dimension" to expand the category.

The Dimension Defaults dialogs can also be accessed by double-clicking the **Dimension Tools**  parent button or the **Automatic Dimension Tools**  parent button.

There are three dimension defaults dialogs:

- [Dimension Defaults Dialog on page 451](#)
- [Auto Story Pole Dimension Defaults Dialog on page 464](#)
- [Temporary Dimension Defaults Dialog on page 467](#)



When **Angle Snaps**  are enabled, dimensions can be drawn at the **Allowed Angles** set in the General Plan Defaults dialog. Regardless of their angles, however, dimensions will only locate objects that are parallel to one another. See [General Plan Defaults Dialog on page 92](#).

When a Marker is created in association with a manually drawn dimension or Auto Elevation Dimension, the Marker will inherit its initial settings from the currently active Saved Marker Defaults. See [Markers on page 529](#).

## SAVED DIMENSION DEFAULTS

Dimensions are an example of objects that use Multiple Saved Defaults. This lets you set dimensions up for more than one task or requirement in advance, and then simply specify which default you want to use as the Active Default at any given time. See [Multiple Saved Defaults on page 79](#).

A Saved Dimension Default can be activated in any view that supports dimensions: plan view, cross section/elevation views, CAD Details, and Wall Details. A Saved Dimension Default can be activated in any of five ways:

- Select a default from the **Active Dimension Defaults Control**  **Default**  drop-down, which can be added to the toolbars. See [To add a button to a toolbar on page 132](#).
- Select a Currently Active Dimension Defaults in the Active Defaults dialog. See [Active Defaults Dialog on page 82](#).
- Select a default in the Saved Dimension Defaults dialog. See [Saved Defaults Dialog on page 80](#).
- Open a saved view in which dimensions are supported. See [Saved Views on page 144](#).
- Select a Default Set. See [Default Sets on page 83](#).

## Dimension Defaults Dialog



Select **Edit > Default Settings**, expand the “Dimension” category, select “Dimensions”, and click the **Edit** button to open the Dimension Defaults dialog.

You can also double-click either the **Dimension Tools**  or **Automatic Dimension Tools**  parent button to open this dialog.

The Manually drawn dimension tools support multiple Saved Defaults for specific drawing tasks. See [Multiple Saved Defaults on page 79](#).

- When you access the Dimension Defaults dialog via the Default Settings dialog, the Saved Defaults dialog will open first, allowing you to select which Saved Manual Dimension Default that you wish to edit. Multiple Defaults can be selected and edited if you wish. See [Shift and Ctrl Select on page 214](#).
- When you access this dialog by double-clicking the **Dimension Tools**  button, the defaults dialog for the currently active Saved Default is opened directly. If you would like the Saved Defaults dialog to open first in this situation, you can enable this option in the Preferences dialog. See [General Panel on page 102](#).
- In either case, the name of the Saved Default being edited will display in the title bar at the top of the dialog box.

The settings in this dialog are dynamic defaults, which means that any changes made here may affect existing dimension lines in the drawing that are using the Saved Manual Dimension Default being edited. See [Dynamic Defaults on page 79](#).

In addition, you can specify how Temporary Dimensions locate walls and CAD objects in the Temporary Dimension Defaults dialog. See [Temporary Dimension Defaults Dialog on page 467](#).

### GENERAL PANEL

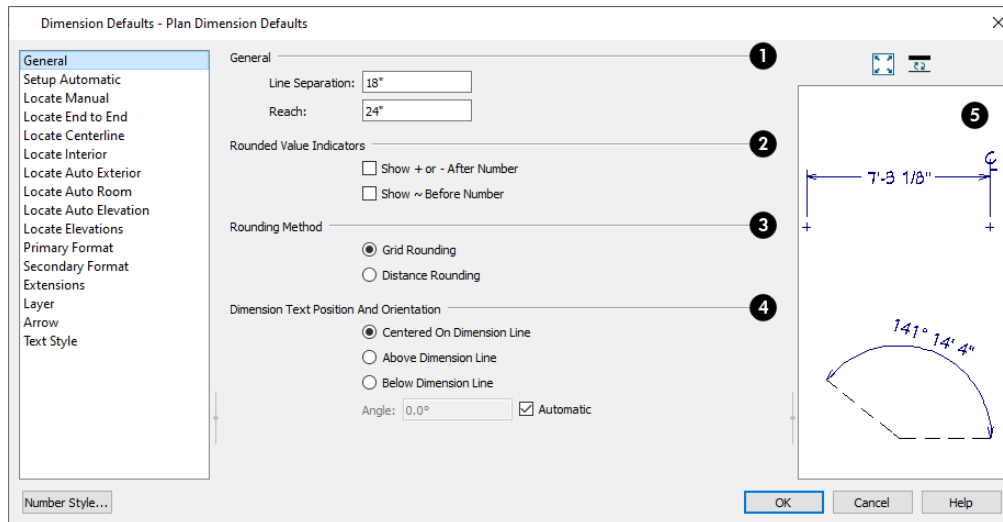

## 1 General

- Specify the **Line Separation**, which is the distance between Baseline Dimension lines in plan inches (mm). This value should always be greater than the Character Height. If two formats are used, it should be at least twice the Character Height. See *Text Style Panel on page 463*.
- Specify how far manually drawn dimension lines **Reach** to locate walls and/or objects specified on the LOCATE panels. The default is 24" (450 mm) in plan files and 1" (10 mm) in layout. See *Locate Manual Panel on page 454*.

## 2 Rounded Value Indicators

Rounded Value Indicators can display when the degree of accuracy in use is not sufficient to describe a dimension's true value.

- Check **+ or - After Number** to indicate that the actual dimension value is higher or lower than the value shown.
- Check **~ Before Number** to indicate dimension values that are not accurate with the ~ symbol.

## 3 Rounding Method

- **Grid Rounding** ensures that the sum of the parts of a dimension line add up to the whole distance. To produce this result, some sections may not be rounded accurately. This is the recommended rounding method and is selected by default.
- **Distance Rounding** addresses each section of a dimension line individually, which could result in the sum of these sections not being equal to the whole. This option is available for legacy purposes only and is not recommended. See *Compatibility With Previous Versions on page 449*.



To avoid the appearance of inaccuracy that rounding may cause, draw with Grid Snaps enabled and place objects in your plan using the same accuracy as your dimensions. See *Grid Snaps on page 163*.

## 4 Dimension Text Position and Orientation

Specify the location and angle of dimension numbers relative to the dimension line.

- **Centered on Dimension Line** centers the primary dimension numbers on the dimension line. If two formats are used, the primary format is placed above the line and the secondary format, beneath it.
- Position dimension numbers **Above Dimension Line**.
- Position dimension numbers **Below Dimension Line**.
- If you would like to specify a specific angle for dimension label text, uncheck **Automatic**. Then, type the desired **Angle**, in degrees, in the text field.

## 5 Preview

A preview of the selected dimension line displays on the right side of the panel. This preview shows a summary of the dimension line's general style attributes rather than its actual appearance. See *Dialog Preview Panes on page 22*.

## SETUP AUTOMATIC PANEL

The settings on the SETUP AUTOMATIC panel affect how automatically generated dimensions are created. See *The Automatic Dimension Tools on page 472*.

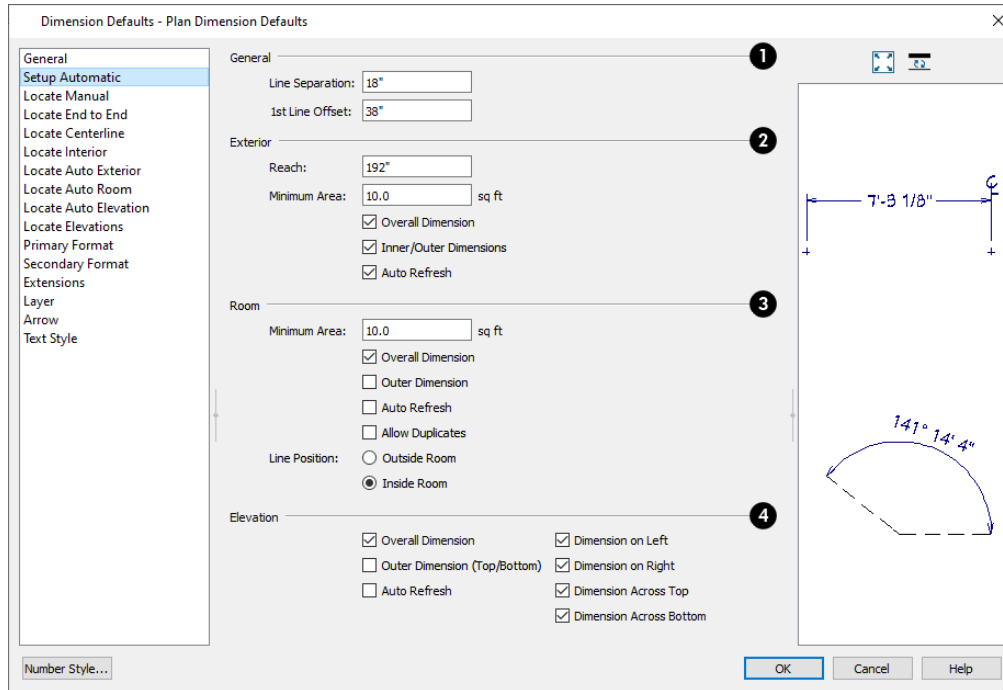

### 1 General

- Specify the **Line Separation**, which is the distance between Auto Exterior Dimension lines in plan inches (mm). This value should always be greater than the Character Height used by the label. If two formats are used, it should be at least twice the Character Height. See [Dimension Labels on page 474](#).
- Specify the **1st Line Offset**, which is the distance between each wall and the nearest Automatic Dimension line that measures its length in plan inches (mm).

### 2 Exterior

These settings control how Auto Exterior Dimensions generate.

- Specify how far Auto Exterior Dimensions **Reach** to locate objects set back from exterior walls. If exterior walls are set back further than this distance, additional dimension lines are produced to locate the set-back walls.
- Specify the **Minimum Area**, which is the minimum area defined as a room needed for Auto Exterior Dimensions to generate.
- When **Overall Dimension** is checked, a dimension line reporting the overall length of each side of the structure is created.
- When **Inner Dimension** is checked, up to three rows of Auto Exterior Dimensions per exterior wall are generated. Uncheck this box to suppress these inner dimension strings.
- Check **Auto Refresh** to delete and replace Auto Exterior Dimensions whenever a change is made to the model that affects them.

### 3 Room

These settings control how Auto Room Dimensions generate.



- Specify the **Minimum Area**, which is the minimum area defined as a room needed for Auto Room Dimensions to generate.
- When **Overall Dimension** is checked and a room's Auto Room Dimensions locate objects in addition to its walls, an overall dimension for each wall is also generated.
- Check **Outer Dimension** to generate an outer dimension that locates objects as specified on the LOCATE ROOM panel.
- Check **Auto Refresh** to delete and replace Room Dimensions whenever a change is made to the model that affects them.
- Check **Allow Duplicates** to generate a full set of dimensions along each wall, potentially creating duplicate overall dimensions.
- Specify the **Line Position**: select **Outside Room** to generate Room Dimensions outside the selected room, or select **Inside Room** to generate them inside the room.

#### 4 Elevation

These settings control how Auto Elevation Dimensions generate in cross section/elevation views.

- When **Overall Dimension** is checked, an overall dimension is created outside each Auto Elevation Dimension string.
- Check **Outer Dimension (Top/Bottom)** to generate an outer dimensions that locate the marks specified on the LOCATE ELEVATIONS panel.
- Check **Auto Refresh** to delete and replace dimensions created by the Auto Elevation Dimensions tool whenever a change is made to the model that affects them.
- **Dimension on/Across** - Check any of these boxes to generate a dimension string on the **Left**, **Right**, across the **Top**, and/or across the **Bottom** of the model.

#### LOCATE MANUAL PANEL

The settings on the MANUAL panel specify how and whether or not **Manual Dimensions** , **Baseline Dimensions** , and **Running Dimensions**  locate specific types of objects.

Similar settings are also found on other panels in this dialog, on the LOCATE OBJECTS panel of the Auto Story Pole Dimension Defaults dialog and in the Temporary Dimension Defaults dialogs.

Changes made on this panel only affect new dimension lines as they are drawn, not those already drawn. Once created, a dimension line's extensions can be edited so that they locate objects in ways not specified here. See [Editing Extension Lines on page 478](#).

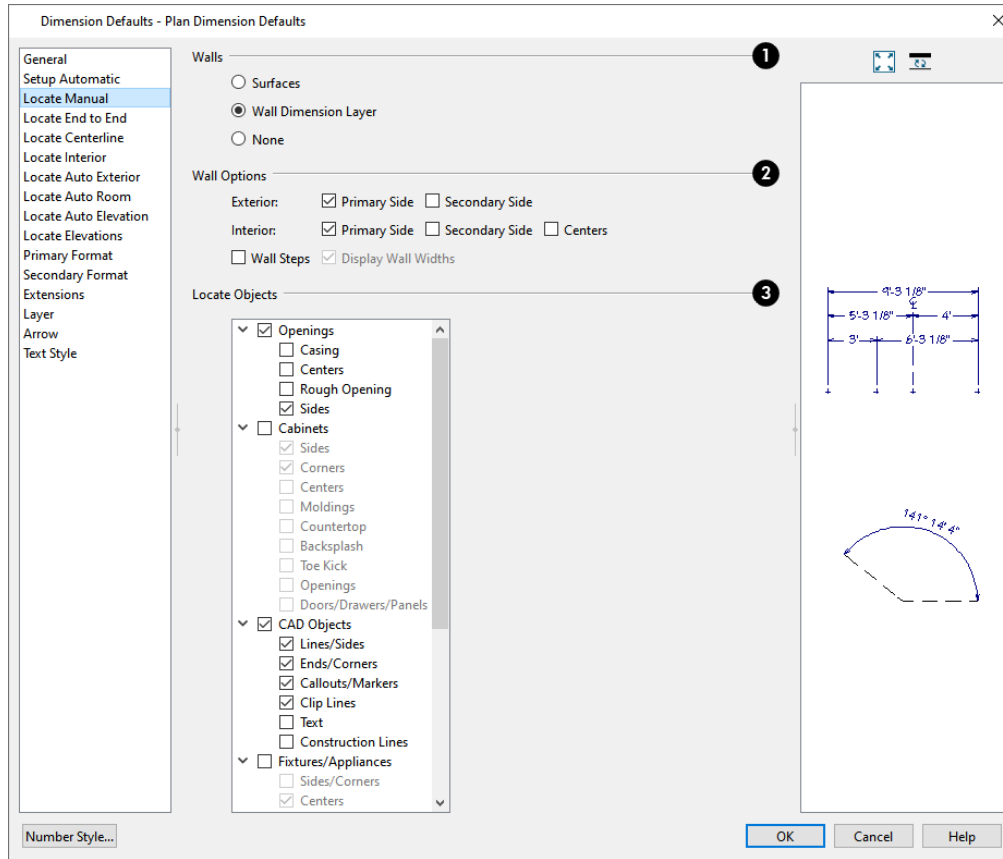

In the Dimension Defaults dialog for a layout file, only the **CAD Objects** settings on this panel is available.

## 1 Walls

Specify the marked location in wall assemblies referred to by Extension Lines as well as the Reach and 1st Line Offset settings. See [The Dimension Layer on page 386](#).

- Select **Surfaces** to locate exterior and interior walls at their surfaces.
- Select **Wall Dimension Layer** to locate walls at their Dimension Layer. A wall's Dimension Layer is specified in its wall type. See [Wall Type Definitions Dialog on page 387](#).
- Select **None** to prevent Manual and Baseline Dimensions from locating walls. Also available for End to End and Centerline dimensions.

## 2 Wall Options

These settings control how or whether exterior and interior walls are located by Manual and Baseline Dimensions. See [Exterior and Interior Walls on page 351](#) and [Primary and Secondary Sides on page 367](#).

- Specify how **Exterior** walls are located:
  - Check **Primary Side** to have dimensions locate the exterior side of exterior walls.
  - Check **Secondary Side** to have dimensions locate the interior side of exterior walls.
  - When neither box is checked, exterior walls are not located by Manual and Baseline Dimensions.

- Specify how **Interior** walls are located:
  - Check **Primary Side** to have dimensions locate the interior side of interior walls. For Auto Exterior Dimensions, this option locates the bottom of horizontal interior walls and the left side of vertical interior walls.
  - Check **Secondary Side** to have dimensions locate the exterior side of interior walls. For Auto Exterior Dimensions, this option locates the top of horizontal walls and the right side of vertical walls.
  - Check **Centers** to have dimensions locate the centers of interior walls.
  - When neither box is checked, interior walls are not located by Manual and Baseline Dimensions.
- Check **Wall Steps** to have dimensions locate steps in walls in elevation views. Steps in foundation walls in plan views are also located. See *Stepped Walls and Footings on page 381*.
- When **Display Wall Widths** is checked, the thicknesses of any walls that a dimension line crosses will be measured. Uncheck this box to suppress the segments dimension line segments that report these measurements.

Note: Walls specified as No Locate will not be located by some dimension tools. See *No Locate on page 368*.

### 3 Locate Objects

- Each category corresponds to a type of object in Chief Architect. Under each category are locations, or marks, on these objects that dimensions can locate.
- Check the box beside an option to have dimension lines locate that mark on objects of that type as they are drawn or generated.
- Uncheck the box beside a category to not locate objects in that category: any checked boxes in that category remain checked, but disabled. Check the box beside a category to locate the selected marks on objects of that type.
- On the LOCATE AUTO ROOM and LOCATE AUTO ELEVATION panels only, there are two scrollable lists: **Outer Dimension** and **Inner Dimension**. Check **Outer Dimension** to generate a second dimension line further from the marked objects than the Inner Dimension, as well as specify the marks that it locates. Not available for other dimension types.



	<b>Cabinets</b>
	Cabinets can be moved and resized in plan and cross section/elevation views. See <i>Using Dimensions on page 635</i> .
<b>Sides</b>	The sides do not have to be perpendicular to the dimension line
<b>Corners</b>	Angled cabinets are dimensioned to their corners at a right angle to the dimension line. A cabinet's front or sides do not need to be perpendicular or parallel to the dimension line for its corners to be located.
<b>Centers</b>	A cabinet's front or sides do not need to be perpendicular or parallel to the dimension line for its center to be located.
<b>Moldings</b>	In elevation views only, locate the tops and bottoms of cabinet moldings.
<b>Countertop</b>	In plan view, a cabinet's front or sides must be perpendicular or parallel to the dimension line for its countertop to be located. In elevation views, only the top and bottom edges can be located when the dimension is being drawn.
<b>Backsplash</b>	In elevation views only, locate the tops and bottoms of backsplash edges.



<b>Toe Kick</b>	In elevation views only, locate the tops and bottoms of toe kicks.
<b>Openings</b>	In elevation views only, locate the top and bottom edges of openings in the cabinet box.
<b>Doors/Drawers/Panels</b>	In elevation views, locate the tops and bottoms of doors, drawers, and panels. In plan views, locate their inner and outer surfaces when Show Closed Doors/Drawers and Panels is enabled. See <i>General Cabinet Defaults on page 619</i> .
	<b>Fixtures/Appliances</b>
	These options affect how dimension lines locate appliances and other fixtures such as hardware, millwork, sprinklers, and Geometric Shapes. In cross section/elevation views, dimensions can only locate furniture at points where a surface is present.
<b>Sides/Corners</b>	For sides to be located, they must be perpendicular to the dimension line
<b>Centers</b>	An object's front or sides do not need to be perpendicular or parallel to the dimension line for its center to be located.
	<b>Furniture</b>
	These options affect how dimension lines locate furniture and furnishing accessories. See <i>Stand-Alone Objects on page 973</i> .
<b>Sides/Corners</b>	For sides to be located, they must be perpendicular to the dimension line.
<b>Centers</b>	An object's front or sides do not need to be perpendicular or parallel to the dimension line for its center to be located.
	<b>Openings</b>
	Specify how dimensions locate doors and windows. Openings in walls specified as No Locate will not be located by Auto Exterior Dimensions. See <i>Doors on page 543</i> , <i>Windows on page 576</i> , and <i>No Locate on page 368</i> .
<b>Casing</b>	Locate the outer edges of both sides of wall openings' casing. Because interior and exterior casing often have different widths, an opening may have different interior and exterior dimensions when this option is selected.
<b>Centers</b>	Locate the centers of wall openings.
<b>Rough Opening</b>	Locate both sides of the rough opening of doors and windows.
<b>Sides</b>	Locate the both sides of wall openings. This option locates the nominal width - not the rough opening.
	<b>CAD Objects</b>
	These options control how dimension lines locate 2D CAD objects as well as CAD-based objects such as slabs and stairs. See <i>CAD Objects on page 290</i> .
<b>Line/Sides</b>	For a line/side to be located, it must be perpendicular to the dimension line.
<b>Ends/Corners</b>	Locate all ends/corners of polylines, no matter what angle they are in relation to the dimension line.
<b>Callouts/Markers</b>	See <i>Callouts on page 521</i> and <i>Markers on page 529</i> .
<b>Clip Lines</b>	See <i>Side Clipping on page 1093</i> .
<b>Text</b>	See <i>The Text Tools on page 497</i> .
<b>Construction Lines</b>	See <i>Construction Lines on page 65</i> .
	<b>Primitives/3D Solids</b>

	All Primitive objects can be moved using dimensions. 3D Solids, Pyramids, and Faces can also be resized. See <i>Primitive Tools on page 1015</i> .
<b>Sides</b>	The sides must be perpendicular to the dimension line.
<b>Corners</b>	Locate the corners of all primitive/solid objects within the Reach area. Corners are dimensioned at a right angle to the dimension line. An object's front or sides do not need to be perpendicular or parallel to the dimension line for its corners to be located.
<b>Centers</b>	Locate the centers of all primitive/solid objects within the Reach area. An object's front or sides do not need to be perpendicular or parallel to the dimension line for its center to be located.
<b>Framing</b>	
	See <i>Using Dimensions on page 883</i> .
<b>Sides</b>	Locate both sides of framing objects.
<b>Centers</b>	Locate the centers of framing objects.
<b>Other Objects</b>	
	Electrical and image objects can be moved using dimensions, but not resized.
<b>Electrical</b>	See <i>Using Dimensions on page 675</i> .
<b>Plants and Images</b>	See <i>Using Dimensions on page 1188</i> .

### LOCATE END TO END PANEL

The settings on the LOCATE END TO END panel are the same as those on the LOCATE MANUAL panel, but control how objects are located when an **End to End Dimension**  or **Point to Point Dimension**  is drawn. See *End-to-End Dimensions on page 470* and *Locate Manual Panel on page 454*.

### LOCATE CENTERLINE PANEL

The settings on the LOCATE CENTERLINE panel are the same as those on the LOCATE MANUAL panel, but control how objects are located when a **Centerline Dimension**  is drawn. See *Centerline Dimensions on page 472* and *Locate Manual Panel on page 454*.

### LOCATE INTERIOR PANEL

The settings on the LOCATE INTERIOR panel are also found on the LOCATE MANUAL panel, but control how objects are located when an **Interior Dimension**  is drawn. See *Interior Dimensions on page 470* and *Locate Manual Panel on page 454*.

### LOCATE AUTO EXTERIOR PANEL

The settings on the LOCATE AUTO EXTERIOR panel are also found on the LOCATE MANUAL panel, but control how objects are located when **Auto Exterior Dimensions**  are generated. See *Auto Exterior Dimensions on page 473* and *Locate Manual Panel on page 454*.

### **LOCATE AUTO ROOM PANEL**

The settings on the LOCATE AUTO ROOM panel are also found on the LOCATE MANUAL panel, but control how objects are located when **Auto Room Dimensions**  are generated. See *Auto Room Dimensions on page 473* and *Locate Manual Panel on page 454*.

### **LOCATE AUTO ELEVATION PANEL**

The settings on the LOCATE AUTO ELEVATION panel are also found on the LOCATE MANUAL panel, but control how objects are located when **Auto Elevation Dimensions**  are generated. See *Auto Elevation Dimensions on page 473* and *Locate Manual Panel on page 454*.

### **LOCATE ELEVATIONS PANEL**

The settings on the LOCATE ELEVATIONS panel determine what elevation marks are located by vertically oriented, manually drawn dimension lines in cross section/elevation views. This panel is also found in the Auto Story Pole Dimension Defaults dialog. See *Locate Elevations Panel on page 466*.

### **PRIMARY FORMAT PANEL**

The settings on the PRIMARY FORMAT panel allow you to specify the units, position, and degree of accuracy of dimension numbers. The settings on this panel also control the format of object length numbers in the Status Bar. See *The Status Bar on page 24*.

These settings are the same as those on the PRIMARY FORMAT panel of the Dimension Line Specification dialog and the DIMENSION FORMAT panel of the Room Label Defaults dialog. See *Dimension Line Specification Dialog on page 485* and *Room Label Defaults on page 415*.

These settings are also similar to those on the INNER, OUTER, and MARKER FORMAT panels of the Auto Story Pole Dimension Defaults and Dimension Line Specification dialogs. See *Auto Story Pole Dimension Defaults Dialog on page 464*.

In addition to these Primary dimension numbers, you can display a set of Secondary dimension numbers that indicate the dimension's length using different units, degree of accuracy, and location. See *Secondary Format Panel on page 461*.

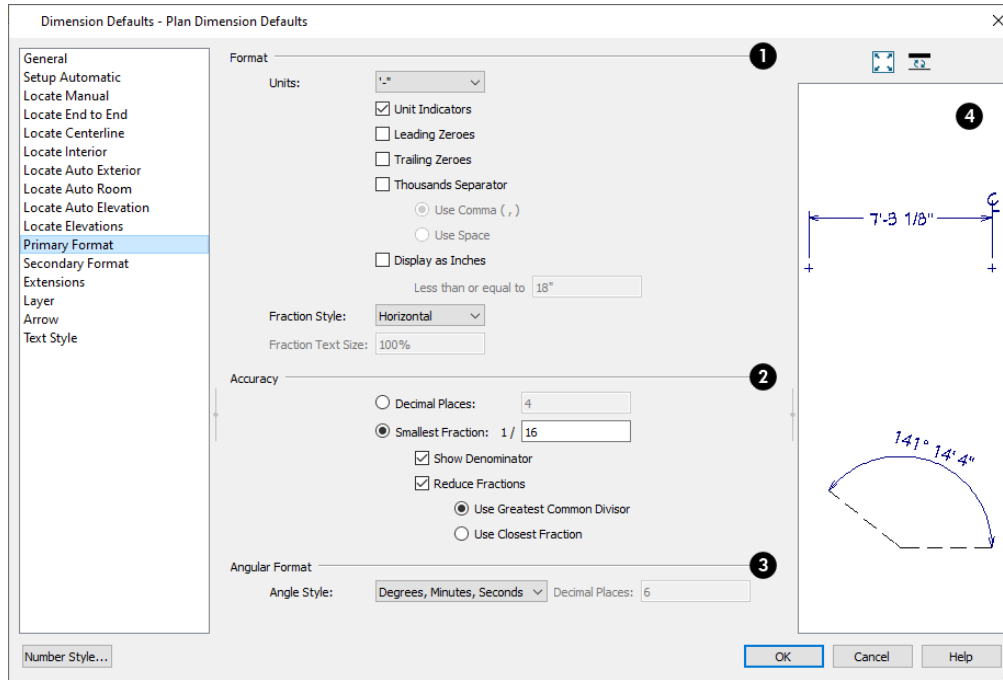

In the Auto Story Pole Dimension Defaults and Specification dialogs only, check **Use Default Formatting** to use the Primary Format settings of the currently active Dimension Defaults as the Inner Format.

## 1 Format

Specify the numbering **Format** for dimension numbers.

- Select the **Units** of measurement to be used by dimensions from the drop-down list. The choices in this list correspond to all units measuring length specified in the Preferences dialog. See *Unit Conversions Panel on page 109*.

Note: Although you can select U.S. or metric units in any plan or layout, it is best to use the same unit type that the file uses to save measurements. See *Units of Measurement on page 38*.

- Check **Unit Indicators** to display the unit of measurement along with the dimension number.
- Check **Leading Zeros** to include the zero before a decimal less than 1 or to display 0' or 0" when the ft-in or '-'" unit formats is used.
- Check **Trailing Zeros** to display trailing zeros at the end of decimal values. When the ft-in or '-'" unit format is used and fractional inches are specified, 0" will be included.
- Check **Thousands Separator** to use a digit grouping symbol for values greater than 999.
- Select the **Use Comma**, **Use Dot**, or **Use Non-Breaking Space** radio button to specify the thousands separator used by dimensions. Which option is available will depend on your operating system settings. See *Region and Language Settings on page 78*.
- Select the **Use Space** radio button to use a space as the thousands separator.
- Check **Display as Inches** to display the dimension number of sufficiently short segments in inches rather than the Unit selected above. This option is only available when the specified Unit is a form of either feet or yards, or a format that includes feet.

- The **Less than or equal to** value specifies how short a segment must be before its number uses inches rather than the specified Unit.
- Select a **Fraction Style** from the drop-down list. This option affects the angle of the fraction's vinculum line and is also applied to the Secondary Format if one is used. See *Secondary Format Panel on page 461*, below.
- Specify the desired **Fraction Text Size** as a percentage of a selected dimension line's Number Height. Only available when either "Diagonal" or "Vertical" are selected as the Fraction Style.

## 2 Accuracy

Specify the degree of accuracy used by dimension numbers.

- Select the **Decimal Places** radio button for dimension numbers in decimal format. In the text field, specify the number of decimal places to use, from 0 to 20. If 0 is used, no decimal places are used.
- Select the **Smallest Fraction** radio button for dimension numbers using whole numbers and fractions. In the text field, specify the largest denominator to use, from 1 to 128. If 1 is entered, whole numbers are used.
- Uncheck **Show Denominator** to turn off the display of fraction denominators used by dimension lines. Typically, denominators are only turned off when eighths are desired.
- Uncheck **Reduce Fractions** to always use the denominator specified above. When checked, the lowest possible denominator will be used. When Smallest Fraction is selected, specify how fractions are reduced:
  - Select **Use Greatest Common Divisor** to reduce fractions using the largest value that divides equally into the numerator and the denominator specified above. This option is best for fractional inches.
  - Select **Use Closest Fraction** to reduce fractions without referring to the denominator specified above. Should only be used with **Distance Rounding**. Not recommended when fractional inches are used.

A value of 0.33333 is represented by the fraction 5/16 when Greatest Common Divisor is used and the Smallest Fraction denominator is 16. When Closest Fraction is selected, this value is represented by 1/3.

## 3 Angular Format

Specify format used by Angular Dimensions. See *Angular Dimensions on page 470*.

- Select an **Angle Style**. For a description of each, see *Dialog Number/Angle Style Dialog on page 126*.
- When **Degrees** is selected, you can specify the number of **Decimal Places** to report.

## SECONDARY FORMAT PANEL

In addition to the Primary dimension label, you can display a set of secondary numbers that indicate the dimension's length using different units and/or degree of accuracy.

The settings on the SECONDARY FORMAT panel of the Dimension Defaults dialog are similar to those on the PRIMARY FORMAT panel, but without the Angular Format settings and with one addition:

- Check **Include Second Format** to use a secondary dimension label and enable the settings on this panel.

The settings on this panel are also the same as those on the same panel of the Dimension Line Specification dialog. See *Dimension Line Specification Dialog on page 485*.

If you choose to use a second format, you may want to increase the default Line Separation on the GENERAL panel. See *General Panel on page 451*.

## EXTENSIONS PANEL

The settings on the EXTENSIONS panel control the length of extension lines.

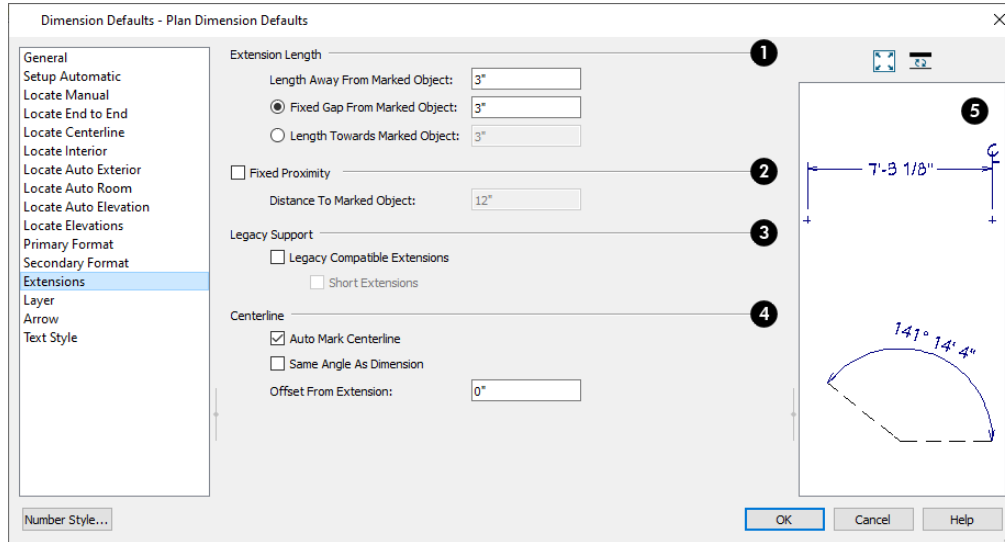

### 1 Extension Length

Specify the **Extension Length** relative to the marked location on an object.

- Specify the **Length Away From Marked Object**, which is the length of the portion of an extension line that extends from the dimension line in the opposite direction of the object it locates.
- Select **Length Towards Marked Object** to specify a fixed length for the portion of an extension line that extends from the dimension line toward the object it locates. If the dimension line is moved, this length remains the same but the size of the gap updates.
- Select **Gap From Marked Object** to specify the distance between the end of extension lines and their marked location in plan inches or mm. If a dimension line is moved, extension lines update, and the size of this gap is maintained.

$$\text{Gap From Marked Object} + \text{Length Toward Marked Object} = \text{Distance to Marked Object}$$

### 2 Fixed Proximity

Specify a fixed length for one extension line that will not change if the object the extension line locates is moved. See [Using Fixed Proximity on page 481](#).

- Check **Fixed Proximity** to specify a fixed distance between the marked object and the dimension line. You can only fix the proximity for a single extension line.
- Specify the **Distance to Marked Object**, which is the distance from the dimension line to the marked object, using a positive value.

Extension Line and Gap lengths are measured from the marked location on a wall. See [The Dimension Layer on page 386](#).

Fixed Proximity only affects dimension lines that locate an object using an extension line. When a dimension line arrowhead points directly to the object without using an extension line, this option has no effect.

Auto Exterior Dimensions ignore Distance to Marked Object and use the default 1st Line Offset and Line Separation values. See [Setup Automatic Panel on page 452](#).

### 3 Legacy Support



These settings are only recommended for files originally created in Chief Architect Version 8 and prior. See [Compatibility With Previous Versions on page 449](#).

- Check **Legacy Compatible Extensions** to assign a program-defined length to extension lines that cannot be edited.
- Check **Short Extensions** to have short, uniform-length extension lines that do not reach all the way to the objects they locate.

Note: If you select an extension line, Legacy Compatible Extensions will be turned off automatically.

### 4 Centerline

See [Centerline Dimensions on page 472](#).

- When **Auto Mark Centerlines** is checked, extension lines that locate the midpoint or center of an object are automatically marked as Centerlines.
- Check **Same Angle as Dimension** to orient Centerline  symbols at the same angle as the dimension line's text. When unchecked, Centerline symbols are oriented vertically, regardless of the angle of the dimension line's text.
- Specify the **Offset From Extension**, which is the distance from the Centerline  symbol and the end of the associated extension line.

### 5 Preview

A preview of the selected dimension line displays on the right side of the panel. This preview shows a summary of the dimension line's general style attributes rather than its actual appearance. See [Dialog Preview Panes on page 22](#).

## LAYER PANEL

The LAYER panel is found in the specification dialogs for many different objects. For more information, see [Layer Panel on page 186](#).

If an automatic dimension line is edited, it will no longer be considered Automatic and the **Default** check box on this panel will be unchecked. See [Editing Dimension Lines on page 476](#).

## ARROW PANEL

The settings on the ARROW panel control the size and style of dimension line arrows. See [Arrowheads on page 327](#).

## TEXT STYLE PANEL



The settings on the TEXT STYLE panel control the size, font and other attributes of automatic, manually drawn, and temporary dimension line labels. Individual dimension lines inherit their text style from a Saved Dimension Default: they cannot have a non-default text style assigned to them. See [Dimension Labels on page 474](#).

For information about the settings on this panel, see [Text Style Panel on page 538](#).

Temporary dimensions and their labels always use the **Selection Line** color set in the Preferences dialog. See [Colors Panel on page 98](#).

## Auto Story Pole Dimension Defaults Dialog

The settings in the Auto Story Pole Dimension Defaults dialogs allow you to control how Auto Story Pole Dimensions are created in cross section/elevation views. See [Auto Story Pole Dimensions on page 473](#).

Select **Edit> Default Settings** , expand the **Dimension** category, select "Auto Story Pole Dimensions", and click **Edit** to access this dialog. It can also be opened by clicking the **Auto Story Pole Dimension Defaults**  button, which can be added to your toolbars. See [To add a button to a toolbar on page 132](#).

As with other types of dimensions, the appearance of Auto Story Pole Dimensions, including size, primary and secondary formats, and extension lines can be set in the Dimension Defaults dialog. The defaults for Auto Elevation Dimensions can be set there, as well. See [Dimension Defaults Dialog on page 451](#).

### GENERAL PANEL

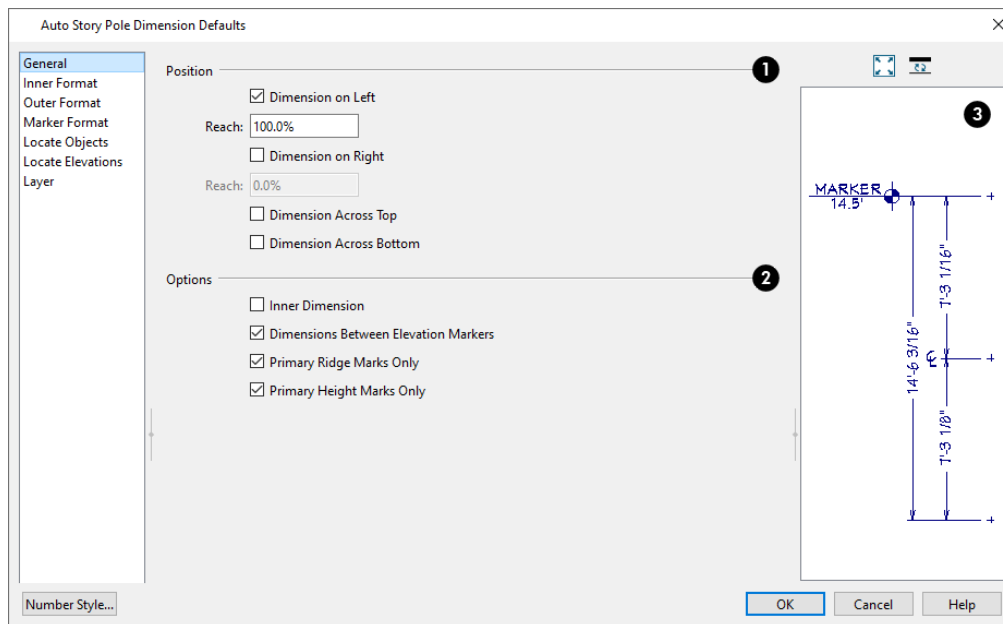

#### 1 Position

The **Position** settings control where automatic elevation dimensions are generated, relative to the model.

- Check **Dimension on Left** to create a dimension string or story pole on the left side of the model in cross section/elevation views.
- Check **Dimension on Right** to create a dimension string or story pole on the right side of the model.
- When either Dimension on Left or on Right is selected, a corresponding **Reach** value can be specified. A Reach of 100% locates marks across the width of the structure while a Reach of 1% only locates marks located 1/100 of the way across. Reach is measured from the structural surface that is closest to the dimension line in the current view, including roof eaves but not including gutters or shadow boards.



- Check **Dimension on Top** to create a dimension string above the model.
- Check **Dimension on Bottom** to create a dimension string below the model.

## 2 Options

Additional **Options** control how many dimension strings are created.

- Uncheck **Inner Dimension** to suppress the inner dimension string and generate only one outer dimension. Only available in the Auto Story Pole Dimension Defaults dialog. See *Auto Story Pole Dimensions on page 473*.
- Uncheck **Dimensions Between Elevation Markers** to suppress the outer dimension string that measures the distances between each of the elevation markers.
- When **Primary Ridge Marks Only** is checked, Auto Story Pole extension lines only locate roof ridges that are exposed to the horizon or backdrop on the surface edge that faces the Auto Story Pole. When unchecked, Auto Story Poles will locate all roof ridges within the specified Reach distance. In order to be located, "Ridges" must be selected on the LOCATE ELEVATIONS panel.
- When **Primary Height Marks Only** is checked, Auto Story Pole extension lines only locate top of subfloor and top plate heights that they can reach without crossing any portion of the model. Uncheck to locate all top of subfloor and top of plate heights located within the Reach distance. In order to be located, "Top of Plate" and "Top of Subfloor" must be selected on the LOCATE ELEVATIONS panel.

## 3 Preview

A preview of an Auto Story Pole dimension line displays on the right side of the dialog box. This preview shows a summary of the dimension's general style attributes only. See *Dialog Preview Panes on page 22*.

### INNER FORMAT PANEL

The settings on the INNER FORMAT panel control the format of the inner string of dimensions on a Story Pole, if present, and are similar to those on the PRIMARY FORMAT panel of the Dimension Defaults dialog. See *Primary Format Panel on page 459*.

- Check **Use Default Formatting** to use the Primary and Secondary Format settings of the Dimension Defaults that are active when a Story Pole is created as the Inner Format. See *Multiple Saved Defaults on page 79* and *Primary Format Panel on page 459*.

### OUTER FORMAT PANEL

The settings on the OUTER FORMAT panel control the format of the outer string of dimensions on a Story Pole and are similar to those on the PRIMARY FORMAT panel of the Dimension Defaults dialog. See *Primary Format Panel on page 459*.

- Check **Use Default Formatting** to use the Primary and Secondary Format settings of the currently active Dimension Defaults as the Outer Format.

### MARKER FORMAT PANEL

The settings on the MARKER FORMAT panel control the format of the elevation value stated in elevation markers' bottom line of text on a Story Pole and are similar to those on the PRIMARY FORMAT panel of the Dimension Defaults dialog. See *Primary Format Panel on page 459*.

- Check **Use Default Formatting** to use the Primary Format settings of the currently active Dimension Defaults as the Marker Format.

Once a Story Pole dimension has been created, Additional Text can be added to the bottom line of marker text in the Dimension Line Specification dialog. See *Segments Panel on page 490*.

## LOCATE OBJECTS PANEL

The settings on the LOCATE OBJECTS panel specify whether or not Auto Story Pole Dimensions locate specific types of objects. See *Locate Manual Panel on page 454*.

## LOCATE ELEVATIONS PANEL

The settings on the LOCATE ELEVATIONS panel control what marks Auto Story Pole Dimensions locate, as well as how Elevation Markers report their heights.

This panel is also found in the Dimension Defaults dialog.

Auto Story Pole Dimensions can also be set to locate additional object types on the LOCATE OBJECTS panel. See *Locate Manual Panel on page 454*.

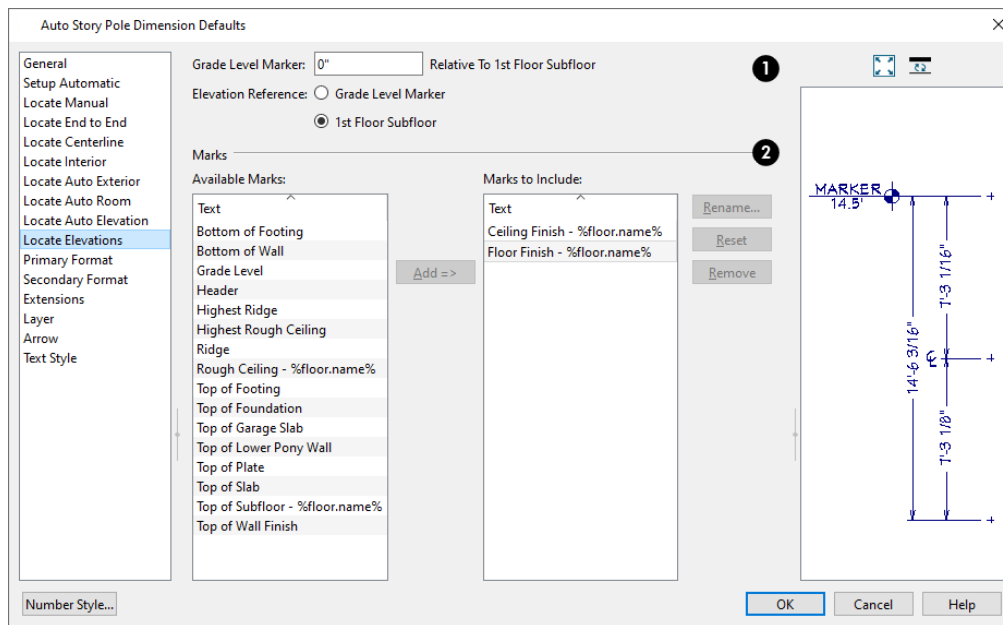

### 1 Grade Level Marker

Specify the position of the **Grade Level Marker** measured **Relative to 1st Floor Subfloor**. This value determines the height at which Grade Level is marked by dimension line Elevation Markers, but is not tied to the location of the terrain.

- If this value is greater than or less than 0 and Grade Level is a Mark to Include, it will be located at this distance above or below the Default 1st Floor Subfloor. See *Floor 1 Default Height on page 414*.
- When this value is 0, Grade Level is marked at the same elevation as the Default 1st Floor Subfloor.
- There is only one Grade Level Marker height in each plan, and it is a dynamic setting. If it is modified in one defaults dialog, its value will change automatically in the other two defaults dialogs and any dimensions with Elevation Markers in the plan will update as well.

Note: The Grade Level setting and the terrain in the plan are completely independent of one another. See *Terrain on page 1243*.

Select the desired **Elevation Reference**, which is the elevation mark that all other marks' elevations are measured relative to.

- Select **Grade Level Marker** to specify the elevation of the Grade Level Marker as 0 and measure all other marks relative to it.
- Select **1st Floor Subfloor** to specify the elevation of the Default 1st Floor Subfloor as 0 and measure all other marks relative to it.

## 2 Marks

Specify which elevation **Marks** are included in vertically-oriented automatic elevation dimensions by default.

- An alphabetical list of **Available Marks** displays on the left.
- Select one or more names in the list, then click the **Add** button to move them to the Marks to Include list on the right. See *Shift and Ctrl Select on page 214*.
- You can also double-click on an item in this list to add it to the Marks to Include.
- A list of the **Marks to Include** displays on the right. At least one column must be included to create a vertical automatic elevation dimension.
- In the Marks to Include list, click in the **Outer** column of any line item to add or remove a check mark. When checked, the selected mark will be included on the outer dimension line of an Auto Story Pole.
- Select or double-click on an item in the Marks to Include list and click the **Rename** button to specify a new name.
- Click the **Reset** button to restore the default names for the selected Marks to Include.
- Select one or more items in the Marks to Include list, then click the **Remove** button to move those items back to the Available Marks list on the left.

Note: Deck framing and planking cannot be automatically located by vertically oriented elevation dimensions. They can, however, be located by manually added extensions. See *Adding an Extension Line on page 478*.



## LAYER PANEL

The LAYER panel allows you to specify what layers Auto Story Pole Dimensions are placed on when they are created. It is found in the specification dialogs for many different objects. For more information, see *Layer Panel on page 186*.

---

# Temporary Dimension Defaults Dialog

The settings in the Temporary Dimension Defaults dialog allow you to control how Temporary Dimensions locate walls and CAD objects. See *Temporary Dimensions on page 473*.

Select **Edit> Default Settings** , expand the **Dimension** category and choose “Temporary”, and click **Edit** to access this dialog. You can also open this dialog by clicking the **Temporary Dimension Defaults**  button, which you can add to your toolbars. See *To add a button to a toolbar on page 132*.

The appearance of Temporary Dimensions, including their size, format, and extension lines, are set along with those of manual and automatic dimensions in the Dimension Defaults dialog. See *Dimension Defaults Dialog on page 451*.

The default settings for manually drawn dimensions are set in the Dimension Defaults dialog.

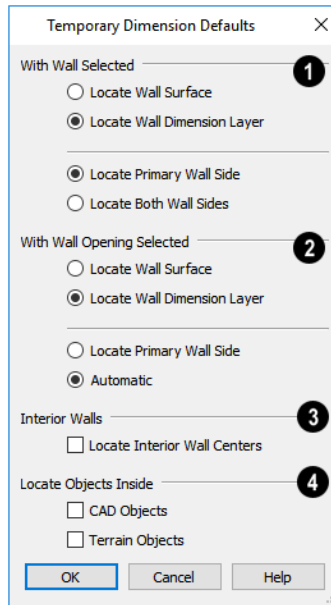

### 1 With Wall Selected

Specify how walls are located by temporary dimensions when a wall is selected.

- Select **Locate Wall Surface** to locate wall surfaces.
- Select **Locate Wall Dimension Layer** to locate wall dimension layers as specified in the Wall Type Definitions dialog. See [Wall Type Definitions on page 384](#).

The next two settings control how temporary dimensions locate interior walls.

- Select **Primary Wall Side** to locate one side of interior walls.
- Select **Both Wall Sides** to locate both surfaces of a selected interior wall. Wall thicknesses are not dimensioned.

Note: Temporary Dimension Defaults do not affect the temporary wall length dimensions that displays when a wall is selected. See [Measuring Walls on page 366](#).

The next two settings control how temporary dimensions locate interior walls.

- Select **Primary Wall Side** to locate one side of interior walls.
- Select **Both Wall Sides** to locate both surfaces of a selected interior wall. Wall thicknesses are not dimensioned.

Note: Temporary Dimension Defaults do not affect the temporary wall length dimensions that displays when a wall is selected. See [Measuring Walls on page 366](#).

### 2 With Opening Selected

Specify how walls are located by temporary dimensions when a door, window, or masonry fireplace in that wall is selected.

- Select **Locate Wall Surface** to locate the wall's surfaces, or **Locate Wall Dimension Layer** to locate the wall's dimension layer.
- Select **Locate Primary Wall Side** to always locate the wall along the exterior side.

- Select **Automatic** to locate the wall’s exterior by clicking on the wall opening near its exterior side, or locate the wall’s interior by clicking on the wall opening near its interior side.

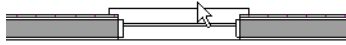

### 3 Locate Interior Wall Centers

Check **Locate Interior Wall Centers** to locate interior walls at their centers instead of their surfaces. When checked, this option overrides the other settings in this dialog for interior walls.

### 4 CAD Options

Specify how CAD objects inside a selected CAD object are located by temporary dimensions.

- Select **Ignore Objects Inside** for temporary dimensions to ignore any other objects inside a selected CAD object.
- Select **Locate First Objects Inside** to locate the first edge of another CAD object drawn inside a selected CAD object.

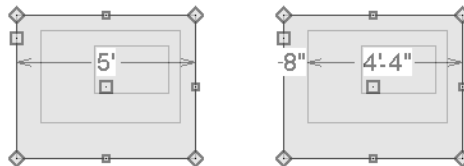

## The Manually Drawn Dimension Tools

 Select **CAD> Dimensions** to access the manually-drawn Dimension Tools.

Manually drawn dimensions are created by clicking and dragging like other line-based objects and can be drawn in plan view, cross section/elevation views, CAD Details, and on layout pages.

 The Automatic Dimension tools can also be used to create dimensions in plan and cross section/elevation views. See [The Automatic Dimension Tools on page 472](#).

There are nine manually drawn Dimension Tools:

With the exception of **Angular Dimensions** , dimension lines only locate objects that are parallel or nearly parallel to one another and should be drawn orthogonal, or at right angles, to the objects being located.

Dimension lines locate objects using **Object Snaps** , although they do not need to be enabled in order to draw dimensions. See [Object Snaps on page 160](#). Bear in mind, though, that Object Snaps must be enabled in order to:

- Locate parallel objects drawn at angles other than Allowed Angles.
- Locate more than one object drawn in the same space, such as a CAD line drawn over a wall.

The zoom factor of the current view affects whether objects drawn close together are dimensioned or not. If you try to dimension an array of objects but the dimension line locates only the first and last objects along its path, **Zoom**  in on the

objects and try again. Similarly, if you want to dimension between two objects but the dimension locates unwanted objects between them, **Zoom**  out. See [Zoom Tools on page 153](#).

Once created, both manually drawn and automatically generated dimension lines can be selected and edited. See [Editing Dimension Lines on page 476](#).

If the object or objects located by a dimension are resized or moved, the dimension will update to reflect the change. Objects located by a dimension can also be accurately relocated or resized by specifying a new dimension value. See [Moving Objects Using Dimensions on page 483](#).

## MANUAL DIMENSIONS



The **Manual Dimension** tool creates dimension lines that locate all eligible objects positioned between their start and end points and within the default Reach distance.

Manual Dimensions locate walls and a variety of other object types as specified in the Dimension Defaults dialog. See [Locate Manual Panel on page 454](#).

## END-TO-END DIMENSIONS



The **End-to-End Dimension** tool creates dimension lines that locate an eligible object at its start and end points but ignores any objects in between.

End to End Dimensions locate walls and a variety of other object types as specified in the Dimension Defaults dialog. See [Locate End to End Panel on page 458](#).

## ANGULAR DIMENSIONS



The **Angular Dimension** tool measures the angle between any two straight edges, including walls, cabinets, and the straight sides of polyline-based objects. Edges nested up to four levels deep within a CAD block can be dimensioned, as well. To create an angular dimension, click on the first edge to be dimensioned, then drag an arc and release on the second edge.

Like other dimension lines, an Angular Dimension can be included in a CAD block. When the block is exploded, however, the Angular Dimension may become invalid and disappear when edited or changed.

By default, Angular Dimensions use the **Angle Style** specified in the Dimension Defaults dialog. See [Primary Format Panel on page 459](#).

## INTERIOR DIMENSIONS



The **Interior Dimension** tool creates dimension lines that measure the interiors of rooms. Interior Dimensions do not locate the exterior sides of exterior walls by default, although they can be edited to do so, and they have **Display Wall Widths** unchecked by default in their specification dialog so they do not report the thicknesses of walls or wall layers. See [Dimension Panel on page 486](#).



**Interior Dimensions** locate either wall surfaces or the Main Layer, as well as a variety of other objects, depending on the settings in the Dimension Defaults dialog. See [Locate Interior Panel on page 458](#).

## POINT TO POINT DIMENSIONS



The **Point to Point Dimension** tool creates dimension lines that locate an eligible object at their start and end points if possible. If no object is present at either location, a Point Marker is created and the dimension line locates it instead. See [Markers on page 529](#).

Point to Point Dimensions can be drawn in either of two ways:

- When the **Default**  edit behavior is active, a Point to Point Dimension places Point Markers at its start and end points, which it locates. Any objects along the dimension line's length are ignored. See [Point Markers on page 298](#).
- When the **Alternate**  edit behavior is active, a Point to Point Dimension locates objects along its length as well as objects or Point Markers at its start and end. See [Defaults, Preferences, and Edit Behaviors on page 206](#).

The Point Markers created by the **Point to Point Dimension** tool can be selected and edited. See [Editing Markers on page 529](#).

**Point to Point Dimensions** locate walls and a variety of other objects depending on the settings in the Dimension Defaults dialog. See [Locate End to End Panel on page 458](#).

## BASELINE DIMENSIONS

 The **Baseline Dimension** tool creates a series of dimension lines that all share the same origin instead of continuing from each previous location. **Baseline Dimensions** are independent and can be edited separately. This tool is not available in layout files.

In plan view, a cross section/elevation view or a CAD Detail, select **CAD> Dimensions> Baseline Dimension** , click near an object and drag a dimension line near or through the objects requiring dimensions.

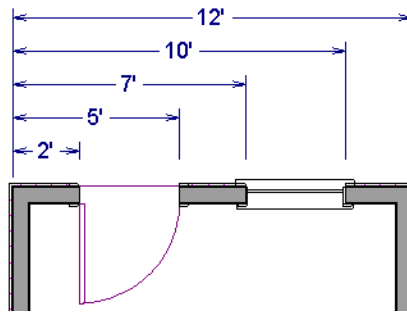

Baseline Dimensions locate walls and a variety of other objects depending on settings on the **MANUAL** panel of the Dimension Defaults dialog, while the spacing between lines is determined by the **Line Separation** value set on the **GENERAL** panel. See [Dimension Defaults Dialog on page 451](#).

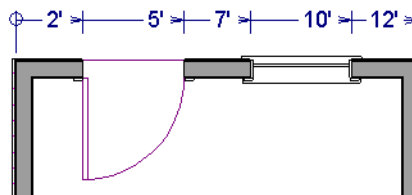

## RUNNING DIMENSIONS

 The **Running Dimension** tool is similar to the Baseline Dimension tool in that it produces multiple measurements from a single point of origin. It is different, though, in that these measurements display on the same dimension line rather than on multiple lines. The start point of a **Running Dimension** line is marked by a circle. The circle's size is the same as the dimension line's Arrow Size.



Running Dimensions locate walls and a variety of other objects as specified on the **LOCATE MANUAL** panel of the Dimension Defaults dialog. See [Locate Manual Panel on page 454](#).

## CENTERLINE DIMENSIONS

 The **Centerline Dimension** tool is available in floor plan and cross section/elevation views. It allows you to locate the centers of a variety of object types using special centerline extension lines, which can be distinguished by a dashed line style and a  symbol.

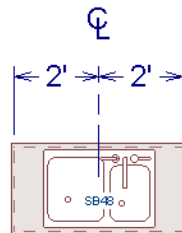



**Centerline Dimensions** locate walls and a variety of other objects as specified on the CENTERLINE panel of the Dimension Defaults dialog. In order for the centers of an object type such as cabinets, fixtures, and wall openings to be located as a dimension line is drawn, **Centers** must be selected for that object type. Both free-standing fixtures and appliances as well as those placed into cabinets can be located by Centerline Dimensions. See [Locate Centerline Panel on page 458](#).

The centers of a variety of other objects - including stairs, footings, electrical, and CAD objects - can also be located with a Centerline by adding an extension at the object's midpoint.

You can also specify any extension line on any dimension line as a Centerline using the **Mark as Centerline**  edit tool as well as in the Dimension Line Specification dialog. See [Mark as Centerline on page 482](#).

## TAPE MEASURE

 Use the **Tape Measure** tool to draw a temporary dimension line between any two points in the drawing area. The tool will place temporary markers at the start and end points of the dimension line. The Tape Measure line and its start and end points all disappear when you release the mouse button. If **Object Snaps**  are enabled and an object is located by the temporary line, you can snap to it.

---

# The Automatic Dimension Tools

 The **Automatic Dimension Tools** allow you to generate dimensions in floor plan and cross section/elevation views for specific purposes. Select **CAD > Automatic Dimensions** to access these tools.

If you edit an Auto Dimension line, it will be marked as edited, so if Auto Dimensions are later regenerated, your changes will not be lost. If an Auto Dimension line has been edited, the **Default** check box will be unchecked on the LAYER panel of its specification dialog. See [Layer Panel on page 491](#).

Each of the **Automatic Dimension**  tools has its own defaults settings so that you can customize the functionality of each independent of the others. See [Dimension Defaults Dialog on page 451](#).

There are seven Automatic Dimension Tools:

 The manually drawn Dimension tools can also be used to draw dimensions in plan and cross section/elevation views. See [The Manually Drawn Dimension Tools on page 469](#).



## TEMPORARY DIMENSIONS

 **Temporary Dimensions** display automatically when an object is selected and report the distance between that object's selected edge and other objects. Select **View > Temporary Dimensions** to turn on or off the display of Temporary Dimensions. This toggle affects all views and is saved between launches of Chief Architect.

A Temporary Dimension will only display when an object is selected, and as with other dimension lines, it will only locate objects that are parallel or nearly parallel to one another. Temporary Dimensions will also locate the endpoints of CAD lines and the corners of objects located past the end of the selected edge, within 4 feet (1200 mm) of the point where you click to select the object.

You can control how Temporary Dimensions locate objects in the Temporary Dimension Defaults dialog. See [Temporary Dimension Defaults Dialog on page 467](#).

## AUTO EXTERIOR DIMENSIONS

 The **Auto Exterior Dimensions** tool generates dimensions around a plan's exterior in plan view, locating walls and openings as specified in the Dimension Defaults dialog.

 Auto Exterior Dimensions require one or more rooms to be defined in order to generate. See [Room Definition on page 413](#).

Up to three rows of automatically generated dimensions may be created per exterior wall:

- The innermost dimension line locates exterior walls, interior walls, and all openings in exterior walls.
- The second dimension line locates exterior and interior walls.
- The outermost dimension line is the overall exterior dimension.

## AUTO ELEVATION DIMENSIONS

 The **Auto Elevation Dimensions** tool generates dimensions that locate walls and other objects in cross section/elevation views, as specified in the Dimension Defaults dialog. See [Locate Auto Elevation Panel on page 459](#).

## AUTO STORY POLE DIMENSIONS

 The **Auto Story Pole Dimensions** tool generates Elevation Markers and dimensions that locate walls and other objects in cross section/elevation views, as specified in the Auto Story Pole Dimension Defaults dialog. See [Auto Story Pole Dimension Defaults Dialog on page 464](#).

Note: Only one set of automatic elevation dimensions created by any of the Auto Dimension tools can exist in a given cross section/elevation view at a time. If you want to have more than one, mark them as edited. See [Editing Dimension Lines on page 476](#).

## AUTO ROOM DIMENSIONS

 Select one or more rooms and click the **Auto Room Dimensions** edit button to generate interior dimensions that measure each wall defining the selected room(s).

Auto Room Dimensions lines are generated inside the rooms they measure and locate walls and wall openings, as well as other objects, as specified in the Dimension Defaults dialog. See [Locate Auto Room Panel on page 459](#).

Auto Room Dimensions do not recognize the **No Locate** setting for walls. If a wall is specified as No Locate, Auto Room Dimensions will locate it anyway. See [No Locate on page 368](#).

## Displaying Dimension Lines



The display of dimension lines is controlled in the Layer Display Options dialog as well as by using Drawing Groups. See [Displaying Objects on page 175](#).

You can customize the both appearance and the display of dimension lines for different purposes. See [Default Sets on page 83](#).

Dimension lines created by any of the dimension tools share the same components:

- **Dimension Lines** run parallel with the distance being measured.
- **Extension Lines** are perpendicular to dimension lines, indicating what they locate. If a dimension line locates more than two objects, extension lines divide the dimension line into segments.
- **Arrowheads** display at the intersections of dimension and extension lines.
- **Dimension Labels** display at the midpoint of dimension line segments and indicate the distance that each segment measures.

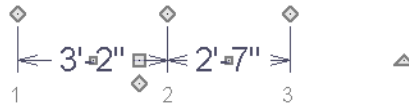

### EXTENSION LINES

If a dimension line is offset from the objects it locates, extension lines help clarify exactly what is being located. Extension lines are numbered: when a dimension line is selected, an Extension Line Number displays at the end of each extension line.

You can specify the default length of extension lines in the Dimension Defaults dialog. See [Extensions Panel on page 462](#).

Once drawn, the appearance of extension lines can be edited. See [Editing Extension Lines on page 478](#).

Any extension line can be specified as a Centerline that displays the  symbol. See [Centerline Dimensions on page 472](#).

In cross section/elevation views, vertically-oriented dimension lines can display Elevation Markers along their extension lines. See [Extensions/Markers Panel on page 488](#).

### DIMENSION LABELS

Manually drawn, automatic, and temporary dimension labels use the Text Style specified in the Dimension Defaults dialog. Unlike many objects that use Text Styles, by default dimensions use a Text Style specified in the defaults dialog rather than the Text Style assigned to their layer. See [Text Style Panel on page 538](#).

 Like other text, dimension labels are subject to scaling. For example, A Character Height of 6" prints a 1/8" tall number at 1/4" = 1' scale. A Character Height of 125 mm prints a 3 mm tall number at 1 m = 50 m scale. See [Printing Text, Dimensions, and Line Styles on page 1373](#).

By default, dimension labels have a solid fill that is the same as the **Background Color** set in the Preferences dialog. You can instead specify that labels use a Text Style with a transparent fill.

You can also specify the minimum size of dimension numbers displaying on screen in the Preferences dialog. See [Appearance Panel on page 95](#).

Labels can have both a primary and secondary format and can be centered on dimension lines or located either above or below them. See [Primary Format Panel on page 459](#).

Dimension labels have their own edit handles and can be moved and rotated when a dimension line is selected. See [Editing Dimension Lines on page 476](#).

## DIMENSION ARROWHEADS

You can specify the style, color and size of dimension arrows in the Dimension Defaults and Dimension Line Specification dialogs. See [Arrowheads on page 327](#).

The arrow at the end of a dimension line will not display if it is close enough to another dimension arrow that the two will overlap. A typical example of this is where two sections of an Interior Dimension locate two sides of an interior wall.

## ELEVATION MARKERS

The **Auto Story Pole Dimensions**  tool creates a story pole with Elevation Markers and dimension strings automatically. See [Auto Story Pole Dimensions on page 473](#).

In addition, Elevation Markers can be added to any vertically-oriented dimension line in a cross section/elevation view.

### *To add an elevation marker*

1. Select an eligible dimension line and note the number of the extension line that you would like to add a marker to. See [Extension Lines on page 474](#).
2. Click the **Open Object**  edit button.
3. On the EXTENSIONS/MARKERS panel of the Dimension Line Specification dialog, select the number you noted in Step 1 from the **Selected Extension** drop-down list.
4. Check the box beside **Draw Elevation Marker**.
5. Type the desired **Elevation Marker Text** then click OK.

The resulting marker will display your text above the line and the height above grade below the line. In addition to the height above grade, you can add Additional Text below the line. See [Segments Panel on page 490](#).



By default, grade level is set at the same height as the default subfloor for Floor 1; however, this can be changed in the Auto Story Pole Dimension Defaults dialog and for dimensions created with other tools, the Dimension Defaults dialog. See [Locate Elevations Panel on page 466](#).

These Elevation Markers inherit their attributes, including marker Type, from the Saved Marker Defaults specified in the Dimension Line Specification dialog. See [Extensions/Markers Panel on page 488](#).

---

## Selecting Dimension Lines

Before a manually-drawn or automatic dimension line can be edited, it must be selected. A dimension line can be selected in one of three ways, each of which affects the ways that the dimension line can then be edited.

The standard way to select an individual dimension line is to click anywhere along its length when the **Select Objects**  or any of the **Manual Dimension**  tools is active. When selected in this manner, the dimension line's full range of editing options are available.

You can instead click on one of the dimension line's extension lines. When selected in this way, the selected extension line's length can be edited and a Centerline marker added to or removed from it; however, fewer edit handles are available overall. See [Editing Extension Lines on page 478](#).

If you select an extension line by mistake, press the Esc key to display the full set of dimension line edit handles.

Dimension lines can also be group-selected, with limited editing options. See [Selecting Multiple Objects on page 213](#).

## Editing Dimension Lines

Before a dimension line can be edited, it must be selected. See [Selecting Dimension Lines on page 475](#).

With the exception of **Temporary Dimensions** , dimension lines can be selected and edited using the mouse, the Edit Toolbar buttons, and the Dimension Line Specification dialog. See [Dimension Line Specification Dialog on page 485](#).

If an Auto Dimension line is edited, it will no longer be considered an automatic dimension line and will not be deleted and replaced the next time the tool used to create it is used.

For information about changing the value reported in a dimension line label, see [Moving Objects Using Dimensions on page 483](#).

### USING THE EDIT HANDLES

When a dimension line is selected, its edit handles can be seen. There are seven types of dimension line edit handles. The total number of edit handles a dimension line has depends on how many extension lines it has.

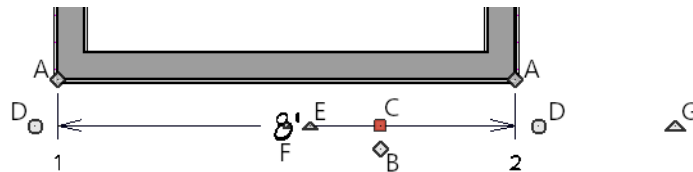

- A. The **Extension Line End** handles are positioned at the point that each extension line locates and are used to move or delete extension lines. See [Moving an Extension Line on page 479](#).
- B. The **Add Extension Line** handle displays to the side of the Move handle and is used to add extension lines to the dimension line. Extension lines added in this manner are able to locate marks that the dimension line might not locate as it was being drawn. See [Adding an Extension Line on page 478](#).
- C. The **Move** handle is located where you clicked to select the dimension line and displays the Selected Edge Handle Fill color. It is used to move the entire dimension line, including any subsections, perpendicular to itself. Extension lines are resized as appropriate. The pointer changes to a two-headed arrow  $\leftrightarrow$  when moved over this handle.
- D. The **Add Segments** handles are located just past the ends of the dimension line and are used to increase the length of the dimension line and locate additional objects with it. The types of objects and their mark points that can be located with this method are dependent on the Dimension Defaults that the selected dimension line inherits its settings from, as well as the tool used to draw it. The Status Bar reports a selected dimension line's type, as does its specification dialog. See [Dimension Panel on page 486](#).

- E. A small triangular **Rotate Dimension Label** handle is located near the center of each dimension segment's label. Use this handle to rotate an individual dimension label.
- F. The small, square **Move Dimension Label** handle is located at the center of the selected label. Use this handle to move the dimension number for each dimension line section. The pointer changes to a four-headed arrow  when moved over this handle. When Object Snaps are enabled, dimension label centers will snap to their associated dimension line.
- G. The **Rotate** handle is located past the end of the dimension line and can be used to rotate the dimension line.

Note: A selected dimension line cannot be moved if Fixed Proximity is checked in the Dimension Line Specification dialog. See [Extensions/Markers Panel on page 488](#).

A selected Angular Dimension has only one edit handle. When you click and drag this handle, the selected Angular Dimension will move. Its length will increase or decrease concentrically depending on which direction it is moved, and the location of its arc center will be maintained.

As a selected dimension line is resized, its drawing behavior and the objects it locates may vary, depending on the Dimension Tool that was used to create it. When selected, Interior, Centerline, Baseline, and Running Dimensions are described as such in the Status Bar. See [The Status Bar on page 24](#).

## USING THE EDIT TOOLS

Dimension lines can be repositioned, copied, and deleted using the Edit Toolbar buttons just like other objects in the program can. See [The Edit Toolbar on page 130](#).

Click the **Edit Extensions**  edit button to edit the lengths of the selected dimension's extension lines. See [Editing Extension Lines on page 478](#).

Click the **Add Additional Text**  edit button to add or replace the text in a dimension line segment's label. See [Add Additional Text on page 482](#).

## DIMENSION NUMBER SIZE

The initial size of dimension numbers is specified in the Dimension Defaults dialog. See [Dimension Defaults Dialog on page 451](#).

You can specify number height for individual dimension lines in the Dimension Line Specification dialog. See [Dimension Panel on page 486](#).

As with text and other objects, dimension number size is subject to scaling when sent to layout or printed. See [Printing Text, Dimensions, and Line Styles on page 1373](#).

## COPYING AND PASTING DIMENSION LINES

Dimension lines can be copied and pasted into any view type that supports dimensions. If a dimension line is copied independent of the objects it originally locates, the pasted dimension line will locate Point Markers. See [Point Markers and Dimensions on page 530](#).

Dimension lines can also be copied and pasted from one plan or layout file to another. Bear in mind that dimension lines use dynamic defaults. If the destination file has a Saved Manual Dimension Default with the same name as that used by the dimension line being copied, the pasted dimension will refer to it. If no such saved default exists in the destination file, the pasted dimension will become associated with the currently active Saved Manual Dimension Default.

## DELETING DIMENSION LINES

There are several ways to delete dimension lines.

You can select any manual or automatic dimension line or group of dimension lines, then press the Delete key or click the **Delete**  edit button. See [Deleting Objects on page 284](#).

The Delete Objects dialog allows you to delete all manually drawn and/or automatic dimension lines at once. See [Delete Objects Dialog on page 285](#).

Individual dimension line segments located between extension lines can also be deleted. If a segment is located between two other segments along the same dimension line, that dimension will be broken in two.

### *To delete a portion of a dimension line*

1. Select any **Dimension Tool** aside from Angular or Auto Exterior Dimensions.
2. Manually draw a dimension line over the segment that you wish to remove, dragging from extension line to extension line.

---

## Editing Extension Lines

Before extension lines can be edited, either they or their dimension line must be selected. See [Selecting Dimension Lines on page 475](#).

Extension lines can be added, edited, and deleted using the edit handles when their dimension line is selected. In addition, extension lines can be individually selected and edited.

Extension lines are also affected by settings in the Dimension Line Specification dialog. See [Extensions/Markers Panel on page 488](#).

## ADDING AN EXTENSION LINE

The Add Extension Line edit handle allows you to locate marks that the dimension line might not have been able to locate as it was being drawn. Interior Dimensions, for example, do not locate cabinets as they are drawn; however, you can add an extension line that locates a cabinet.

### *To add an extension line*

1. Select the dimension line anywhere along its length.
2. Click the diamond-shaped Add Extension Line edit handle which displays near the Move edit handle. The pointer changes to a two-headed arrow .
3. Drag the handle to the object that you want to locate with a new extension handle. This example adds an extension line to the left side of the window.

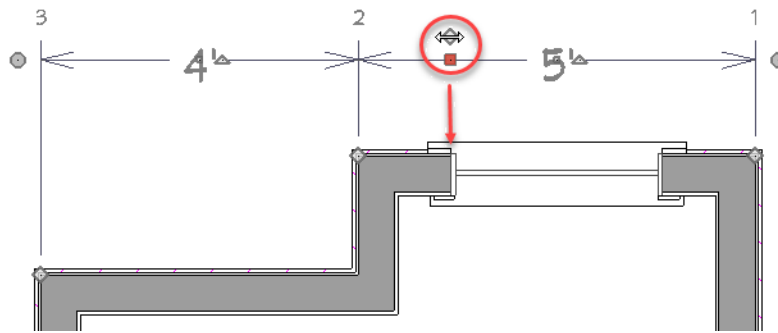

4. Release the mouse button to add an extension line.

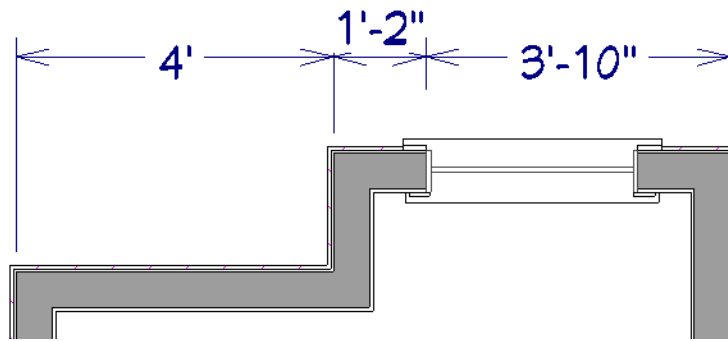

 Additional extension lines can also be created by clicking and dragging an Add Segments edit handle. See *Editing Dimension Lines* on page 476.

### MOVING AN EXTENSION LINE

Extension lines can be moved to locate the centers, sides, or surfaces of most objects. Here, an extension line is moved from the window edge to the center.

#### *To move an extension line*

1. Select the dimension line anywhere along its length: do not click on the extension line itself.
2. Click the Extension Line edit handle. The pointer changes to a two-headed arrow ↔.

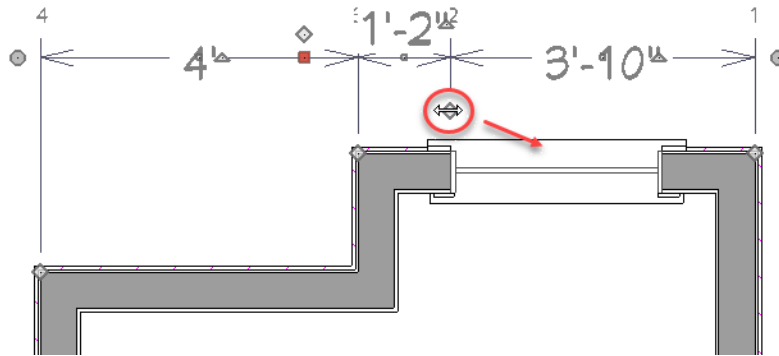

3. Drag the handle to a new location. The extension line snaps to possible marks as the handle is moved.
4. Release the mouse button at the new location.

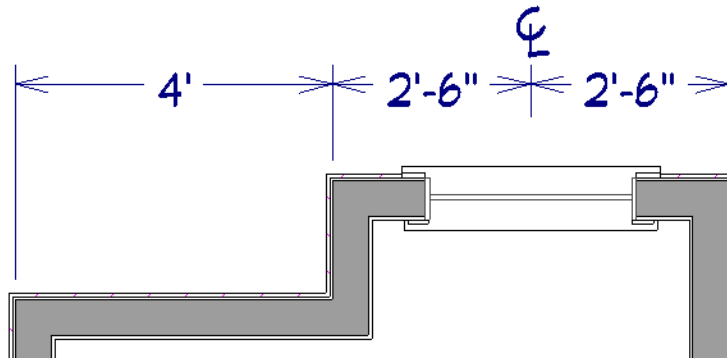

 Not all library symbols can be located by a dimension line as it is drawn. Once a dimension is drawn, however, you can move or add an extension line to locate the library object.

### DELETING AN EXTENSION LINE

When an extension line is deleted, the remaining dimensions update. If a dimension line has only two extension lines, they cannot be deleted.

#### *To remove an extension line*

1. Select the dimension line anywhere along its length: do not click on the extension line itself.
2. Click the Extension Line edit handle.



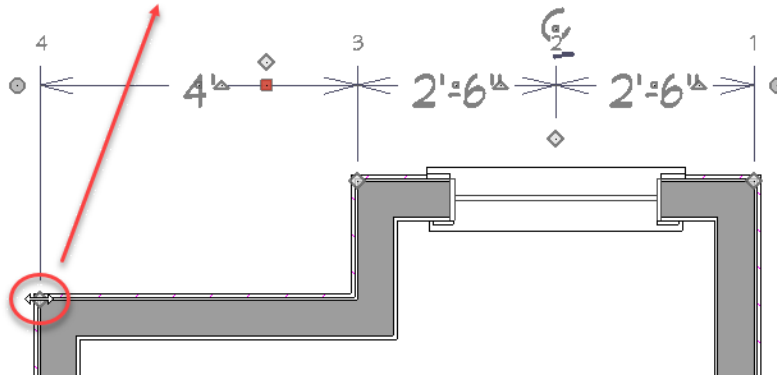

3. Drag it perpendicular to the direction of the arrows, away from any dimensionable object, and release the button when the extension line disappears.

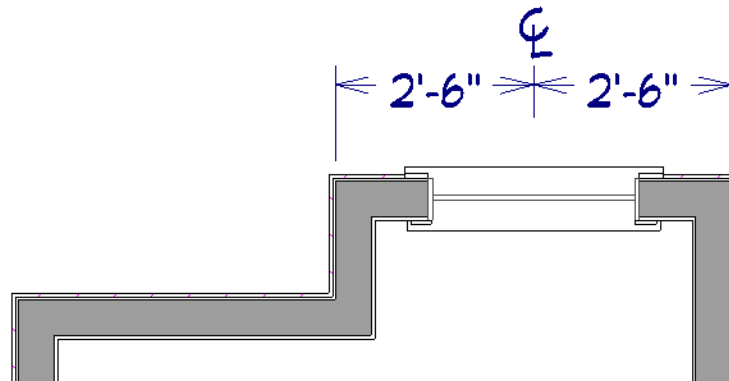

In addition, individual extension lines can be selected, allowing you to resize them and/or mark them as Centerlines.

## RESIZING EXTENSION LINES

You can resize extension lines in the Dimension Line Specification dialog or using their edit handles. See [Extensions Panel on page 462](#).

### *To resize an extension line*

1. Click on the extension line or select the dimension line and click the **Edit Extensions**  edit button to display two handles along the extension line.



2. Click either handle, turning the pointer into a two-headed arrow  $\leftrightarrow$ .
3. Extend or contract the extension line and release the mouse.

## USING FIXED PROXIMITY

The **Fixed Proximity** option allows you to specify a fixed length for one extension line that will not change if the object the extension line locates is moved.

### To use Fixed Proximity

1. Select a dimension line that locates multiple independent objects and note the Extension Number of the extension line that you would like to have a fixed length.
2. Open the Dimension Line Specification dialog and go to the EXTENSIONS panel. See [Extensions/Markers Panel on page 488](#).
  - Select the Extension Number that you noted in step 1 from the **Selected Extension** drop-down list.
  - Check **Fixed Proximity**.
  - Specify the desired **Distance to Marked Object**, which is the distance from the selected dimension line to the object that the Selected Extension locates. This distance includes the Gap From Marked Object.
  - Click **OK**.

To see how Fixed Proximity works, select the object that the extension line with Fixed Proximity specified and move it. Notice that the dimension line moves in response and that all extension lines' lengths adjust except for the one with Fixed Proximity specified.

### MARK AS CENTERLINE

Any extension line can be specified as a Centerline. Click on an extension line to select it, and then click the **Mark as Centerline**  edit button. See [Centerline Dimensions on page 472](#).

Similarly, the Centerline can be removed from an extension line using the **Remove Centerline Mark**  edit button.

## Add Additional Text

 Text can be added to any manual or automatic dimension line using the **Add Additional Text** edit tool.

### To add text to a dimension label

1. Select a dimension line that you would like to add text to.
2. Click the **Add Additional Text**  edit button.
3. Click on the segment of the dimension line with the label you wish to add text to.

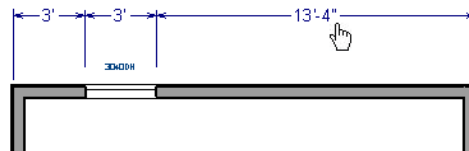

4. In the Additional Text dialog:

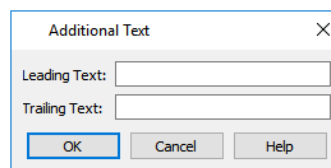

- Type any **Leading Text** that you want to display before the dimension value.
  - Type any **Trailing Text** that you want to display after the dimension value.
  - Check **Suppress Dimension Value** to prevent the dimension value from displaying in the selected segment at all.
5. When you click OK, the segment you selected will display the added text.

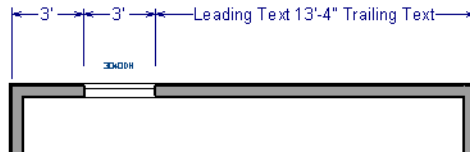

Additional Text can also be added and edited in the Dimension Line Specification dialog. See [Segments Panel on page 490](#).

If a dimension segment has an elevation marker associated with it, any added text will also be added to the marker's bottom line of text. See [Marker Format Panel on page 488](#).

You can check **Highlight Overridden Dimension Text** in the Preferences dialog to identify any dimension label text that replaces a suppressed dimension value. See [General Panel on page 102](#).

Note: Dimension lines with text added are not supported when exported to .dxf/.dwg. When exported, they are converted to text and CAD lines. The same occurs when CAD Detail from View is used. See [CAD Detail from View on page 338](#).

---

## Moving Objects Using Dimensions

Most objects can be moved by changing an automatic, manual, or temporary dimension value that locates it. This technique can be applied in nearly any situation where dimensions are present, including angular dimensions. See [Moving Objects on page 243](#).

In addition, some objects can be resized using dimensions. See [Resizing Objects on page 253](#).

Your pointer indicates which dimensions can be used to relocate the selected object by changing to a pointing hand  icon.

Another way to tell is to select an object and drag it in the desired direction. As you drag, note which dimensions update. These dimensions are the dimensions that can be used to move that object.

Note: A selected object can be moved and resized using a dimension line even when that dimension's layer is locked. See [Locking Layers on page 178](#).

### *To move an object using dimensions*

1. Select the object and click on a dimension line that locates it. An inline text field opens at the location where you clicked.
  - The actual distance displays in the text field using the default primary format. See [Primary Format Panel on page 459](#).
  - If the dimension is locating two different objects and the selected object is polyline-based, the **Move Edge** and **Move Entire Object** buttons display to the right of the text field.

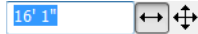

- If the dimension describes a selected wall's length, additional buttons display to the right. See *Using Dimensions on page 369*.



2. Click the **Move** button of your choice.
3. Enter a new value in the text field. The unit of measurement is set in the Number Style/Angle Style dialog. See *Dialog Number/Angle Style Dialog on page 126*.
  - To use a different unit, include its indicator after the value.
  - To move the selected object past a second object, to its opposite side, enter a negative value.
  - Basic math operations can also be performed in the inline text box, just as they can in dialogs. See *Units and Math Operations in Dialogs on page 20*.
4. The selected object moves or resizes when you press the Enter key or click outside the text field.
5. If **Bumping/Pushing**  is enabled, the object being moved will bump into any objects in its move path and not move the entire distance. Hold down the Ctrl key when you press Enter to override this move restriction. See *Bumping/Pushing on page 243*.

A variety of polyline- and box-based objects can also be resized using dimensions.

### ***To resize an object using dimensions***

1. Select the object along the edge that you would like to move. See *Selected Edge on page 212*.
2. Click on a dimension line that indicates its distance from the object's opposite side.
3. In the inline text field, enter a value.
4. Click **Move edge** to move the selected edge only.
5. The selected edge moves, resizing the object, when you press the Enter key.

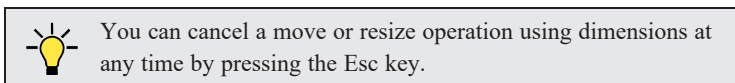

## **RESIZING WALLS USING EXTERIOR DIMENSIONS**

When resizing a structure using dimensions, it is important to work your way around it in one direction. Relocate one wall at a time in succession so that you do not redefine the same dimension more than once.

For more information, see *Measuring Walls on page 366*.

## **USING ANGULAR DIMENSIONS**



**Angular Dimensions** are useful for adjusting the angles of polyline-based objects and walls.

### To change an angular dimension

1. Draw an **CAD> Dimensions> Angular Dimension** , then click and drag to draw an arc within the angle you wish to measure.
2. Select the edge that you want to move.
3. Click the dimension value to open the Set Angular Dimension dialog.

The Set Angular Dimension dialog reports the **Previous Value** in degrees, minutes and seconds.

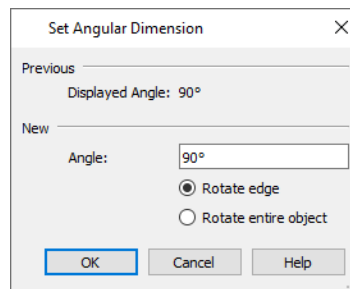

4. Enter a value in the **New Value** field.
5. Specify what you want to rotate:
  - Select **Rotate edge** to move the selected edge when you click OK, or
  - Select **Rotate entire polyline** to rotate the entire object about the corner formed by the edges that the Angular Dimension locates, maintaining the previous value of that angle.
6. Click **OK** to apply the change.

---

## Dimension Line Specification Dialog

 To open the Dimension Line Specification dialog, select one or more dimension lines and click the **Open Object** edit button.

The settings in this dialog are dynamic defaults associated with a particular Saved Manual Dimension Default. See [Dimension Defaults Dialog on page 451](#).

The Dimension Line Specification dialog has up to nine panels, depending on the type of dimension line selected:

## DIMENSION PANEL

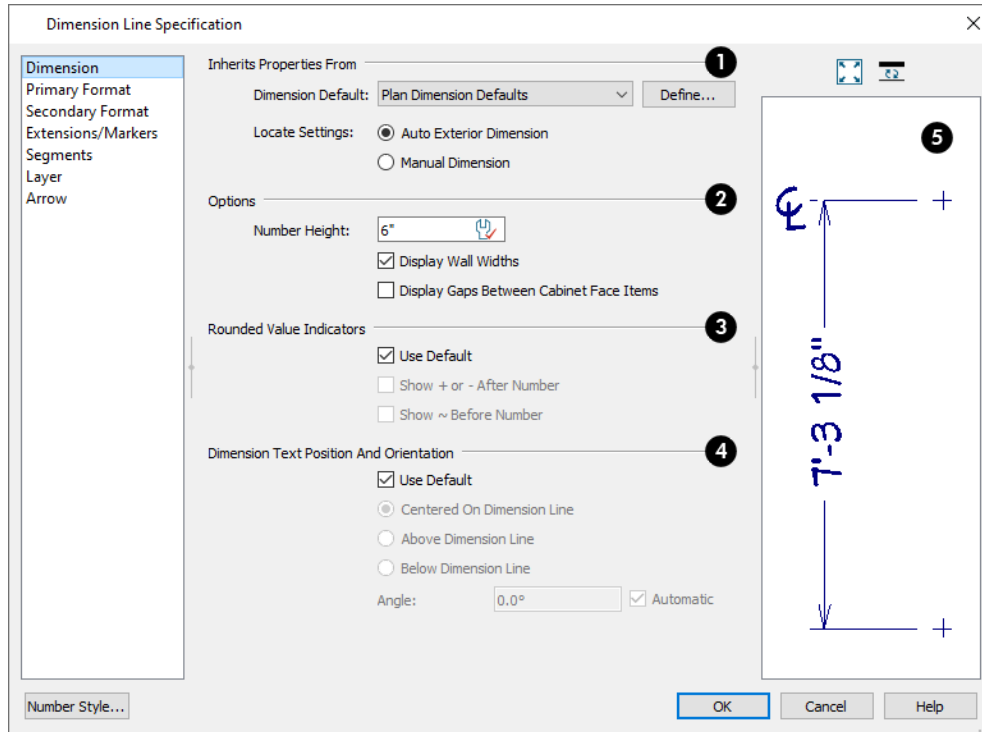

### 1 Inherits Default Properties From

The name of the Saved **Dimension Default** that the selected dimension line gets its default attributes from displays here. If a dimension line inherits attributes from a Saved Dimension Default, that default cannot be deleted. See [Saved Defaults Dialog on page 80](#).

- If multiple dimension lines are selected, “No Change” may display here.
- You can select a different Saved Dimension Default from the drop-down list.
- The **Locate Settings** associated with the tool used to draw the selected dimension line is stated here for reference. A Manual Dimension line uses Locate Settings from the LOCATE MANUAL panel of the Dimension Defaults dialog, for example, while an Interior Dimension line uses settings from the LOCATE INTERIOR panel. These settings affect how the dimension line behaves when edited. See [Using the Edit Handles on page 476](#).
- Depending on the type of dimension line selected, you may be able to choose between the **Locate Settings** of two tools: the one that originally created the dimension line, and **Manual Dimension**.

### 2 Options

Specify the text size and display of wall widths attributes for the selected dimension line. The minimum on-screen size can be set in the Preferences dialog. See [Appearance Panel on page 95](#).

- Specify the **Number Height** of the selected dimension's labels. See [Dynamic Defaults on page 79](#).

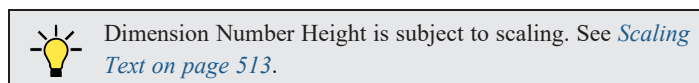

- Uncheck **Display Wall Widths** to suppress those portions of the dimension line that measure between two surfaces of the same wall. Both sides of a wall may still be located, but its width will not display. This option is checked by default for most manually drawn dimensions, but is unchecked for **Interior Dimensions** .
- Check **Display Gaps Between Cabinet Face Items** to show those portions of the dimension line that measure the gaps between cabinet face items in elevation views. This option also controls dimension lines that locate opening edges and the nearest cabinet box edge. When unchecked, these gaps are measured but will not display.

### 3 Rounded Value Indicators

Specify the use and appearance of **Rounded Value Indicators**, which can display when the degree of accuracy in use is not sufficient to describe a dimension's true value.

- Check **Use Default** to use the default indicator(s). Uncheck this box to make the options that follow active.
- Check **+ or - After Number** to indicate that the actual dimension value is higher or lower than the value shown.
- Check **~ Before Number** to indicate dimension values that are not accurate with the ~ symbol.

### 4 Dimension Text Position and Orientation

Specify the location and angle of dimension numbers relative to the dimension line. These settings are also found in the Dimension Defaults dialog. See [General Panel on page 451](#).

### 5 Preview

A preview of the selected dimension line displays on the right side of the panel. This preview shows a summary of the dimension line's general style attributes rather than its actual appearance. See [Dialog Preview Panes on page 22](#).

## DIMENSION PANEL FOR ANGULAR DIMENSIONS

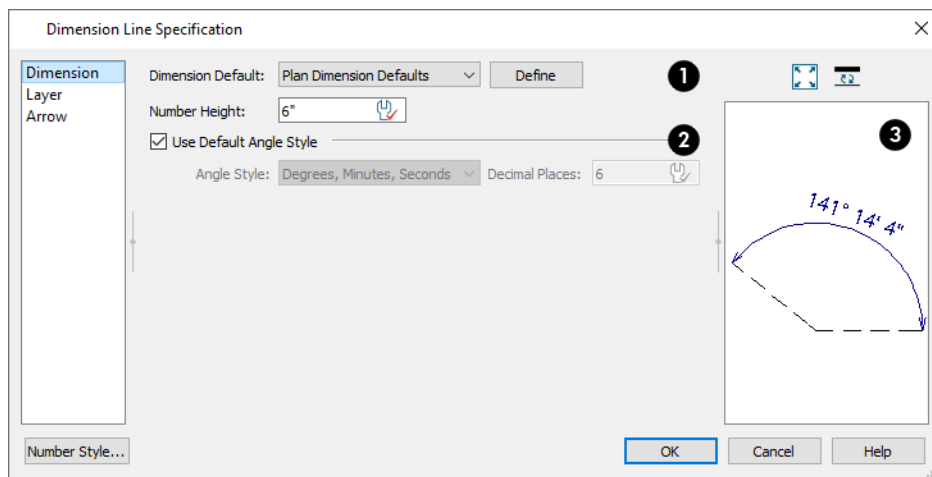

### 1

- The name of the Saved **Dimension Default** that the selected dimension gets its default attributes from displays here. You can select a different Saved Default from the drop-down list.
- Specify a **Number Height** for the selected dimension. See [Dynamic Defaults on page 79](#).

## 2 Use Default Angle Style

When this box is checked, the selected dimension uses the angle style set in the Dimension Defaults dialog. Uncheck this box to select a different **Angle Style** and number of **Decimal Places**. See [Primary Format Panel on page 459](#).

## 3 Preview

A preview of the selected dimension line displays on the right side of the panel. This preview shows a summary of the dimension line's general style attributes rather than its actual appearance. See [Dialog Preview Panes on page 22](#).

## PRIMARY FORMAT PANEL

To enable the settings on the PRIMARY FORMAT panel of the Dimension Line Specification dialog, uncheck **Use Default Formatting**.

The settings that follow are the same as those on the same panel of the Dimension Defaults dialog, but apply only to the selected dimension line(s). See [Primary Format Panel on page 459](#). Not available for Angular Dimensions.

## SECONDARY FORMAT PANEL

To enable the settings on the SECONDARY FORMAT panel of the Dimension Line Specification dialog, uncheck **Use Default Formatting** and then check **Include Second Format**.

The settings on this panel are the same as those on the same panel of the Dimension Defaults dialog, but apply only to the selected dimension line(s). See [Secondary Format Panel on page 461](#). Not available for Angular Dimensions.

## MARKER FORMAT PANEL

The settings on the MARKER FORMAT panel control the format of the elevation value stated in elevation markers' bottom line of text on a Story Pole and are similar to those on the PRIMARY FORMAT panel of the Dimension Defaults dialog. See [Primary Format Panel on page 459](#).

This panel is only available if the selected dimension line is drawn vertically in a cross section/elevation view. See [Detailing Cross Section/Elevation Views on page 1094](#).

- Check **Use Default Formatting** to use the Primary Format settings of the currently active Dimension Defaults as the Marker Format.

Leading and trailing text can be added before and after the elevation value in an elevation marker's bottom line of text on the SEGMENTS panel of the Dimension Line Specification dialog. See [Segments Panel on page 490](#).

## EXTENSIONS/MARKERS PANEL

The settings on the EXTENSIONS/MARKERS panel allow you to edit the selected dimension line's extensions. See [Editing Extension Lines on page 478](#).

This panel is not available for multiple dimensions selected as a group or for **Angular Dimensions** .

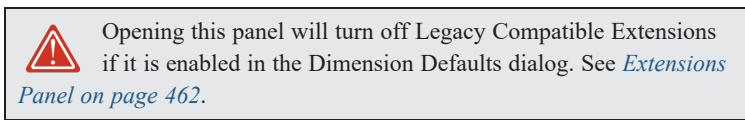



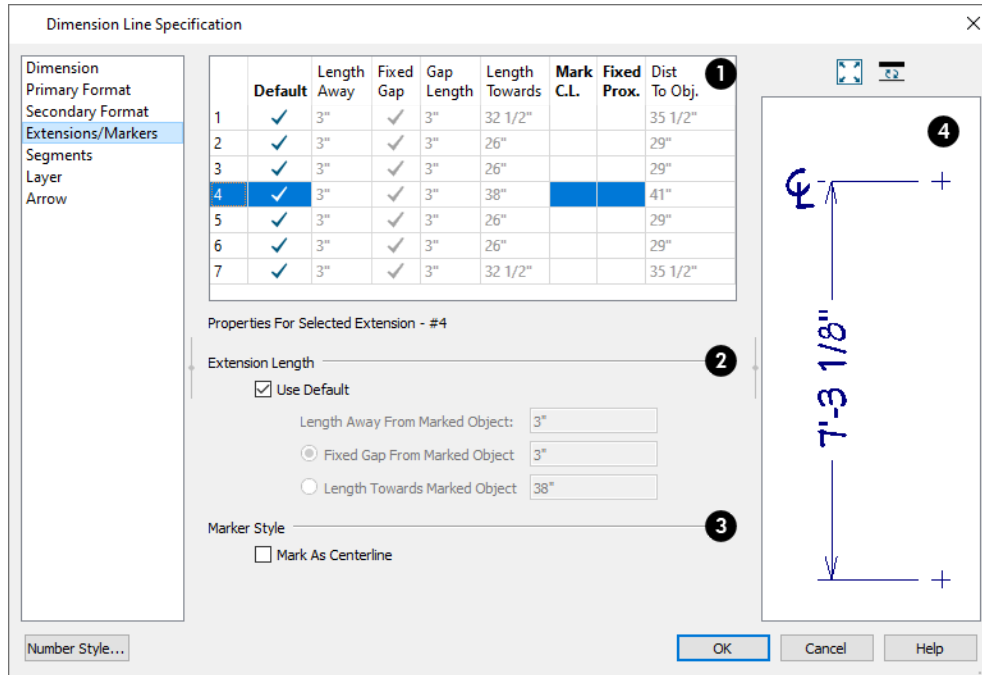

## 1 Extension Lines

An editable table lists the selected dimension line's extensions here. Initially, the extension closest to the point where you clicked to select the dimension line will be highlighted. The highlighted extension line is selected and can be edited.

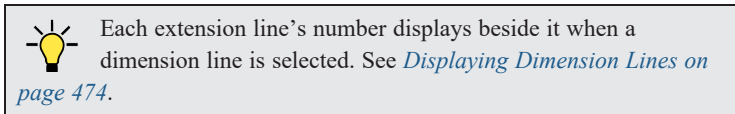

- Click on a line item to select and edit it. The **Properties for Selected Extension** are listed and can be edited using the settings below.
- The available Extension Length and Marker Style settings can also be edited in the table. The available options depend on which Extension Length option is selected below, as well as the view type.
- Only available in the table, click in the **Fixed Proximity** column to specify a fixed distance between the marked object and the dimension line. You can only fix the proximity for a single extension line. See [Using Fixed Proximity on page 481](#).
- When Fixed Proximity is checked, specify the **Distance to Marked Object**, which is the distance from the dimension line to the marked object, using a positive value.

## 2 Extension Length

These settings are the same as those in the Dimension Defaults dialog, but apply to the extension lines associated with the selected dimension line only. See [Extensions Panel on page 462](#).

- Uncheck **Use Default** to enable the three settings that follow as well as the equivalent fields for the selected line item in the table above.
- Check **Use Default** to restore the default settings to the Selected Extension line.

- Specify the **Length Away From Marked Object**, which is the length of the portion of an extension line that extends from the dimension line in the opposite direction of the object it locates.
- Select **Length Towards Marked Object** to specify a fixed length for the portion of an extension line that extends from the dimension line toward the object it locates. If the dimension line is moved, this length remains the same but the size of the gap updates.
- Select **Gap From Marked Object** to specify the distance between the end of extension lines and their marked location in plan inches or mm. If a dimension line is moved, extension lines update, and the size of this gap is maintained.

### 3 Marker Style

These settings provide alternatives to the standard extension line style. The selected extension line may have Mark as Centerline checked, or Display Elevation Marker, but not both.

- Check **Mark as Centerline** to mark the selected extension line with a Centerline  symbol. Not available in the Dimension Defaults dialog. See [Mark as Centerline on page 482](#).
- Check **Draw Elevation Marker** to add an elevation marker to the selected extension line. Only available for vertically oriented dimension lines in cross section/elevation views. See [Elevation Markers on page 475](#).
- Specify the **Elevation Marker Text**, which is the text that accompanies an Elevation Marker. This will be pre-populated if the selected extension line locates an elevation mark recognized by the program. Only available when Draw Elevation Marker is selected, above. See [Locate Elevations Panel on page 466](#).
- Specify which Saved Marker Defaults the selected extension line's **Marker Inherits Properties From**. Only available when Draw Elevation Marker is selected above, this setting determines the marker's size and appearance. See [Multiple Saved Defaults on page 79](#).
- Click the **Define** button to modify the selected Saved Marker Defaults. See [Marker Defaults on page 495](#).

### SEGMENTS PANEL

Additional Text can be added to the label of any segment of the selected dimension line on this panel as well as using the **Add Additional Text**  edit tool. See [Add Additional Text on page 482](#).

If the selected segment has an elevation marker associated with its extension line, the marker's lower text will also receive this Additional Text. See [Auto Story Pole Dimensions on page 473](#).

This panel is not available for multiple dimensions selected as a group or for **Angular Dimensions** .

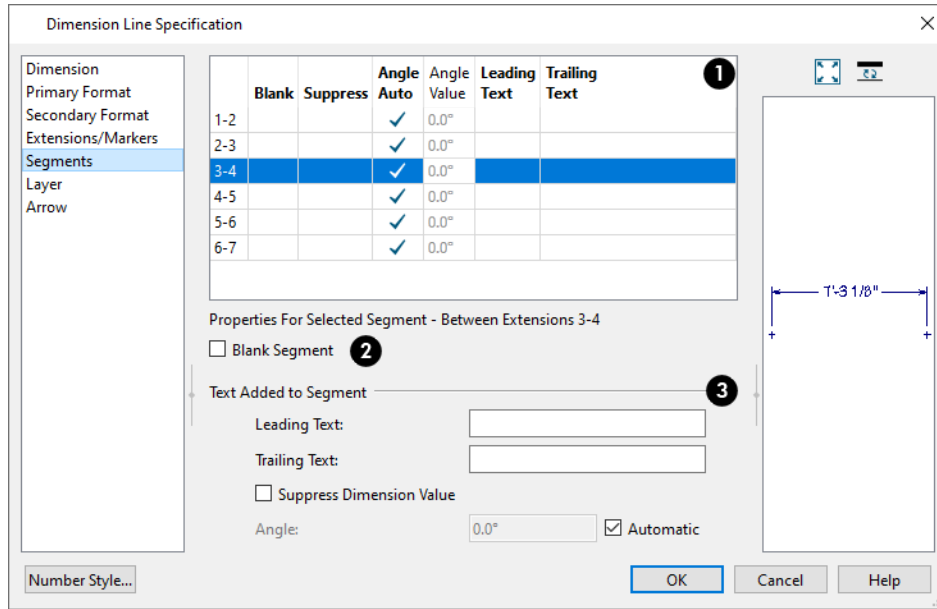

### 1 Segments

An editable table lists the selected dimension line's segments here. Initially, the segment that was clicked on when the dimension line was selected will be highlighted. The highlighted extension line is selected and can be edited.

Each extension line's number displays beside it when a dimension line is selected. See *Displaying Dimension Lines on page 474*.

### 2 Blank Segment

Check **Blank Segment** to suppress the selected segment's dimension label. When this box is checked, the settings that follow are disabled.

### 3 Text Added to Segment

Specify any required text to add to the selected segment and elevation marker, if one is present.

- Type the **Leading Text**, which appears before the dimension value in the label.
- Type the **Trailing Text**, which appears after the dimension value in the label.
- Check **Suppress Dimension Value** to prevent the dimension value from displaying in the selected segment at all.
- To specify the **Angle** of the dimension label associated with the selected segment, uncheck **Automatic** and then enter a value in the text field, in degrees. If the label has been rotated using its edit handle, Automatic will be unchecked and its angle will be reported.

## LAYER PANEL

The LAYER panel is found in the specification dialogs for various objects. For more information, see *Layer Panel on page 186*.

If the selected dimension line was automatically generated, the **Default** check box on this panel will be unchecked automatically if the dimension line is edited. See *The Automatic Dimension Tools on page 472*.

## **ARROW PANEL**

For information about the settings on this panel, see *Arrowheads on page 327*.

# Text, Callouts, and Markers

## Chapter 14

The Text Tools help you draw attention to special details of your drawings. Text objects can be added in plan view, in cross section/elevation views, in CAD Details, and to layout pages.

The display of text can be controlled by layer or set specifically for each text object.





### TOPICS

<b>Text Defaults and Preferences</b> .....	<b>494</b>
<b>Fonts and Alphabets</b> .....	<b>495</b>
<b>The Text Tools</b> .....	<b>497</b>
<b>Creating Text Objects</b> .....	<b>497</b>
<b>Displaying Text Objects</b> .....	<b>499</b>
<b>Rich Text Specification Dialog</b> .....	<b>500</b>
<b>Text Specification Dialog</b> .....	<b>506</b>
<b>Editing Text</b> .....	<b>510</b>
<b>Copying and Pasting Text</b> .....	<b>514</b>
<b>Find/Replace Text and Spell Check</b> .....	<b>516</b>
<b>Text Arrows</b> .....	<b>519</b>
<b>Callouts</b> .....	<b>521</b>
<b>Linked Callouts</b> .....	<b>524</b>
<b>Callout Specification Dialog</b> .....	<b>526</b>
<b>Markers</b> .....	<b>529</b>
<b>Marker Specification Dialog</b> .....	<b>531</b>
<b>Notes, Note Types, and Note Schedules</b> .....	<b>533</b>
<b>Note Specification Dialog</b> .....	<b>535</b>
<b>Note/Callout Panel</b> .....	<b>536</b>
<b>Text Styles</b> .....	<b>538</b>
<b>Text Macros</b> .....	<b>540</b>

## Text Defaults and Preferences

 Text Defaults can be accessed by selecting **Edit > Default Settings** in any view in which text can be created. Click the "+" next to **Text, Callouts and Markers** to display the sub-headings. See [Default Settings vs Preferences on page 77](#).

The default settings for Rich Text, Text, Callouts, Markers, and Arrows determine what these objects look like when they are first created. Text Style Defaults determine the appearance of text associated with things like dimensions and object labels.

**Rich Text** , **Text** , **Callouts** , **Markers** , and **Arrows**  can support multiple Saved Defaults. In order to open the defaults dialog for any of these tools, you must first open its Saved Defaults dialog and choose an available saved defaults setup. See [Multiple Saved Defaults on page 79](#).

- When you access a defaults dialog for any of the Text Tools via the Default Settings dialog, the Saved Defaults dialog will open first, allowing you to select which Saved Default you wish to edit. Multiple Defaults can be selected if you wish. See [Shift and Ctrl Select on page 214](#).
- When you access this dialog by double-clicking a **Text Tool** button, the defaults dialog for the currently active Saved Default is opened directly. If you would like the Saved Defaults dialog to open first in this situation, you can enable this option in the Preferences dialog. See [General Panel on page 102](#).
- In either case, the name of the Saved Default being edited will display in the title bar at the top of the dialog box.



Changes made to default settings do not alter existing text objects, so it is a good idea to go over these settings before placing text.

### TEXT STYLE DEFAULTS

Select "Text Style" from the list in the Default Settings dialog and click the **Edit** button to open the Saved Text Style Defaults dialog. The **Text Style Defaults**  button can be added to your toolbars. See [To add a button to a toolbar on page 132](#).

The Text Style Defaults dialog allows you to specify the attributes of the various Text Styles in use in the current file. See [Text Styles on page 538](#).

### RICH TEXT DEFAULTS

Double-click the **Rich Text**  or **Leader Line**  tool to open the Saved Rich Text Defaults dialog and edit the currently active Saved Default.

The Rich Text Defaults dialog is similar to the Rich Text Specification dialog, but the name of the current Saved Default displays in the title bar. See [Rich Text Specification Dialog on page 500](#).

**Leader Lines** and **Text Lines with Arrows** use the same default layer as Rich Text, so by default they have the same color, line weight and line style. See [Layers on page 176](#).

### TEXT DEFAULTS

Double-click the **Text**  tool to open the Saved Text Defaults dialog and edit the currently active Saved Default.

The Text Defaults dialog looks almost the same as the Text Specification dialog, but the name of the current Saved Default displays in the title bar. See [Text Specification Dialog on page 506](#).

## CALLOUT DEFAULTS

Double-click the **Callout**  tool to open the Saved Callout Defaults dialog and edit the currently active Saved Default.

The Callout Defaults dialog looks almost the same as the Callout Specification dialog, but the name of the current Saved Default displays in the title bar. See [Callout Specification Dialog on page 526](#).



## MARKER DEFAULTS

Double-click the **Marker**  tool to open the Saved Marker Defaults dialog and edit the currently active Saved Default.

The Marker Defaults dialog looks almost the same as the Marker Specification dialog, but the name of the current Saved Default displays in the title bar. See [Marker Specification Dialog on page 531](#).

## ARROW DEFAULTS

Double-click the **Text Line with Arrow**  tool to open the Saved Arrow Defaults and edit the currently active Saved Default.

The settings in the Arrow Defaults dialog determine the initial settings for arrows drawn using the **Leader Line** , **Text Line with Arrow**  and **Line With Arrow** tools. These settings also determine the initial appearance of arrows when they are added to CAD lines, arcs, and polylines.

The Arrow Defaults dialog looks almost the same as the ARROW panel of the Line Specification dialog, but the name of the current Saved Default displays in the title bar. See [Arrowheads on page 327](#).

 Avoid typing any text in any text Defaults dialog unless you want it to be present in all text objects you create.

## DEFAULT SETS

The Text Tools are among the items associated with Default Sets, which are groups of Saved Defaults that can be customized and activated for specific drawing tasks. See [Default Sets on page 83](#).

## PREFERENCES



Specify the number of segments for new leader lines and whether pressing the Enter key creates a new line of text or closes the Rich Text and Text Specification dialogs in the Preferences dialog. See [Text Panel on page 101](#).

---

# Fonts and Alphabets

Chief Architect allows you to use any font found in your computer's Fonts directory.

For best printed results, using true-type or open-type fonts is recommended.

## CHIEF BLUEPRINT FONT

The Chief Blueprint font is installed in the Windows Fonts directory when Chief Architect is installed.

On Mac systems, this font is embedded with the Chief Architect Premier X15 installation but not installed on the system. As such, it is available for use in Chief Architect Premier X15 but not in other programs.

## INTERNATIONAL ALPHABETS





The **Rich Text**  tool supports unicode alphabets and characters. In order to use a unicode alphabet or characters, the appropriate language support must be installed on your computer. See *The Text Tools on page 497*.

Special characters can be added to any **Rich Text**  object by:

- Copying and pasting the character from another application;
- Copying and pasting the character from the Windows Character Map;
- Using the Mac Character Viewer;
- Typing the keystroke associated with the character.

See *Copying and Pasting Text on page 514*.

## CHARACTER SIZE

**Rich Text** , **Text** , **Callouts** , **Markers** , **Schedules** , and dimension numbers can be sized to 1/128” accuracy (0.078125 mm). See *Text Style Panel on page 538*.

These objects use CAD Style Font Sizing, which specifies text size as the measurement from the baseline to the topmost part of the capital letter A, as in most CAD programs.

In legacy files migrated into Version X15, an additional **Legacy Compatible Size** option will be available for some objects if it was specified in the original program version. When this method is used, text size is based on information stored in the font that is then modified to approximate the specified Character Height.

**Rich Text**  objects have two font sizing methods to choose from: **CAD Style Font Sizing** and a method similar to most word processing applications, where size is based on information stored in the font. See *Options Panel on page 505*.

## REPLACE FONTS

 Select **Edit> Replace Fonts** to replace one or more fonts in the current file with a different font using the Replace Fonts dialog.

The Replace Fonts dialog will also open if you open a plan or layout file that uses a font that is not installed on the current computer, giving you an opportunity to replace that font.

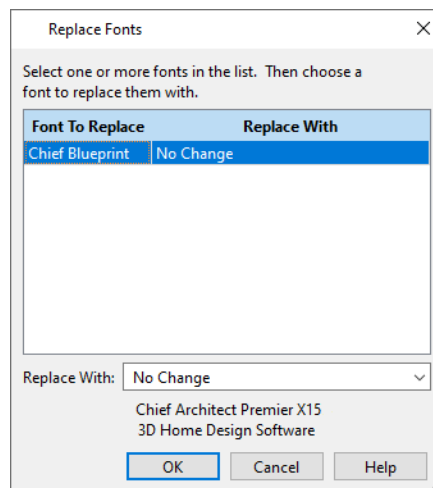



The table lists all fonts in the current file and how they will be replaced.

- Click on a font name in the list to select it. Use the Shift or Ctrl key to select multiple fonts. See *Shift and Ctrl Select on page 214*.
- Select a replacement font from the **Replace With** drop-down list, or leave “No Change” as the selection to maintain the file’s association with the missing fonts.
- A preview of the selected font displays below the **Replace With** list.

If this dialog opens in response to missing fonts and you do not plan to return the file to the computer where it was created, you may want to replace missing fonts with the fonts you normally use. On the other hand, if you do intend to return the file, you may prefer to not replace any missing fonts.

---

## The Text Tools

**T** Select **CAD> Text** to access the **Text Tools**. These tools are available in plan view, in cross section/elevation views, in CAD Details, and in layout files.



The **Rich Text** tool is used to create text objects. See *Creating Text Objects on page 497*.



The **Text** tool is used to create simple text objects with a single font and style format, or with Tab-delimited columns. It is not as flexible as the **Rich Text** tool; however, it was the tool used to create text in Chief Architect X1 and prior. See *Creating Text Objects on page 497*.

 You can convert simple Text to a Rich Text object by clicking the Convert to Rich Text edit button. See *Convert to Rich Text on page 512*.



The **Text Line with Arrow** tool is used to connect text and another object with an arrow. See *Text Arrows on page 519*.



The **Leader Line** tool places either a Text or Rich Text object with an arrow attached. See *Leader Line on page 519*.



The **Callout** tool is used to place callouts. See *Callouts on page 521*.



The **Marker** tool is used to place markers for **Level Lines**, **Test Borings** and **Point Markers**. See *Markers on page 529*.



The **Note** tool is used to create callouts that are associated with a Note Schedule. See *Notes, Note Types, and Note Schedules on page 533*.



The **Text Macro Management** tool allows you to create and manage text macros in the current file. See *Text Macro Management Dialog on page 1396*.



The **Note Type Management** tool allows you to manage the different types of Notes available in the current file. See *Note Type Management Dialog on page 534*.

---

## Creating Text Objects

Text, callouts and markers can be created in plan view, in cross section/elevation views, in CAD Details, and on layout pages. See *View Windows on page 144*.

Notes can be created in these views as well. In addition, they can be created in camera views. See *Notes, Note Types, and Note Schedules on page 533*.

Once created, text, callouts and markers can be selected and edited in a variety of ways. See [Editing Text on page 510](#).

### To create Rich Text

1. Select **CAD> Text> Rich Text** .
2. Click and drag to draw a rectangle defining the area of the text object.
  - The rectangle that you drag must be at least as tall as the default line spacing for a single line of text. See [Rich Text Specification Dialog on page 500](#).
  - When you release the mouse button, a blank text box is created with an active cursor, ready for you to type.

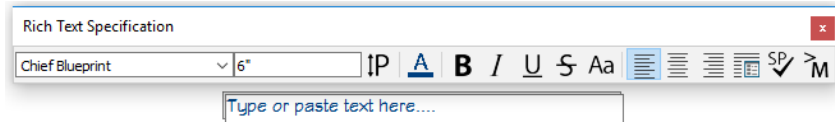





3. Type or paste the desired text into the Text Field. If the program identifies any spelling issues, they will be underlined in red.
4. Use the options on the Edit Bar, which displays above the Text Field, to change the font, style and size of any portion of the text. See [Editing Text on page 510](#).
5. When you are finished, simply click outside the Text Field to close it and the Edit Bar. The **Rich Text**  tool remains active, so you can click and drag to create additional Text objects if you wish.

Note: If you do not type anything in the Text Field, a text object will not be created when you click outside it.

### To create Text

1. Select **CAD> Text> Text** .
2. Click where you want the upper left corner of the text to be located. The Text Specification dialog opens. See [Text Specification Dialog on page 506](#).
3. Enter text and click **OK**.

Up to 32,000 characters can be inserted in one **Text** object. It is usually better to use several smaller **Text** objects when a lot of text must be inserted.

**Rich Text** , **Callouts** , **Markers** , and **Notes**  can also be created in the same manner as **Text** : by clicking where you want the upper left corner of the object to be created. The object's specification dialog will open: enter text and click OK.

You can also create lines with arrows connecting the text that you create to items in the drawing. See [Text Arrows on page 519](#).

## PLACING TEXT FROM THE LIBRARY

 **Rich Text**, **Text**, **Callouts**, **Markers**, and **Notes** can be added to the User Catalog in the Library and then placed into plans and layout files as needed. See [Add to Library on page 965](#) and [Replace From Library on page 976](#).

## TEXT AND CAD OBJECTS

Text can be used in combination with CAD objects to create legends, title blocks, and a wide variety of other details. See [CAD Objects on page 290](#) and [Layout on page 1333](#).



A selection of legends and other CAD blocks that use both text and CAD can be found in the Library Browser. See *The Library on page 945*.

## HYPERLINKS

 Hyperlinks that link to web pages both in the views they are created in as well as when printed to PDF can be added to Rich Text objects in their specification dialogs. See *Text Panel on page 500*.

Hyperlinks can also be added to simple Text objects that can be used in the views they are created in but not when printed. These hyperlinks can link to both web pages as well as files on the local system. See *Link Panel on page 509*.

To open a link in Chief Architect, select a Rich Text or Text object, then:

- Mouse over the text in the selected Rich Text object. If the mouse pointer displays a pointing hand  icon, the Status Bar will report the address that it links to, and you can click once to open the link in your default web browser.
- When a Text object with a hyperlink is selected, the **Follow Hyperlink**  edit button will be available. Click this button to open the linked file, or the linked page in your default web browser.

---

## Displaying Text Objects

As with other types of objects, the display of Text objects is controlled in the Layer Display Options dialog. By default, text objects are located on layers with “Text” at the beginning of the layer name, such as “Text, Callouts”. See *Layer Display Options Dialog on page 179*.

Text objects can only be displayed in views where text can be created.

The display attributes of each individual text object can be controlled independent of the layer it is placed on. See *Rich Text Specification Dialog on page 500*.

## CUSTOM TEXT LAYERS

Text objects do not need to be shown at all times. For instance, electrical notes will be included with the electrical plan, but are not needed in the framing plan. You can create custom layers and layer sets to control the display of text and other objects. See *Layer Sets on page 182* and *Layer Display Options Dialog on page 179*.

To move text to a different layer, select the text object or group of text objects, then click the **Open Object**  edit button to open the Text Specification dialog. The selected text object’s layer can be changed on the LINE STYLE panel. See *Line Style Panel on page 305*.

## TEXT ARROWS

If a text arrow is attached to a **Text**  object and they are on the same layer, changing the layer of the text will also change the layer of the attached text arrow. However, changing the layer of the text arrow will not change the layer of the text it is attached to. See *Layer Attributes on page 177*.

## NOTES

Unlike other text objects, Notes can be created and display in camera views. See *Notes, Note Types, and Note Schedules on page 533*.

## Rich Text Specification Dialog

The Rich Text Specification dialog opens if you select one or more Rich Text objects, then click the **Open Object** edit button.

This dialog also opens when you select the **Rich Text**  tool and then click once in the drawing area.

When **Rich Text** objects are group-selected, the text content, zoom factor, and Paragraph Options cannot be changed, but everything else can be.

The Rich Text Specification dialog is similar to the Rich Text Defaults dialog but affects the selected text rather than all subsequently created text objects. Also, the name of the Saved Default being edited will display in the title bar of the defaults dialog. See *Text Defaults and Preferences on page 494*.

Note: Text objects have a different specification dialog. See *Text Specification Dialog on page 506*.

### TEXT PANEL

The settings on the TEXT panel allow you to type the selected Rich Text object's content and control many aspects of its appearance, including its font, size, color and style.

You can specify the appearance of the text before typing, and can also select and change the attributes of all or portions of the text content after it is typed. To change text that already exists, simply highlight it using the mouse and/or the Shift + arrow keys and then make any needed changes to its attributes.

Note: If you do not type anything in the text field on this panel when creating a new object, no object will be created when you click OK. On the other hand, if you remove the text from an existing object and click OK, an empty text box will result.

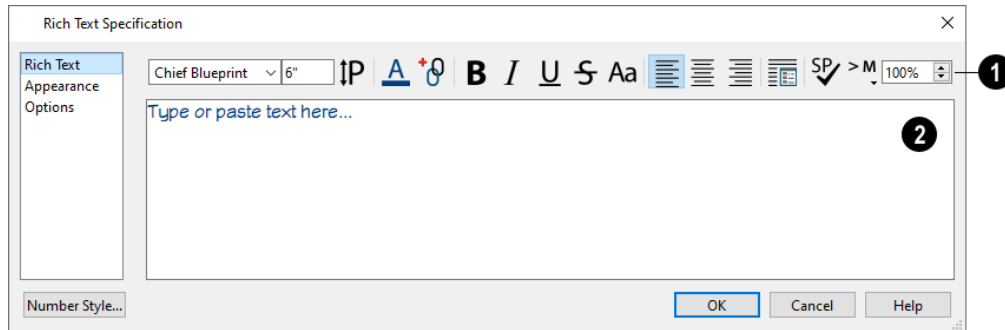



### 1 Edit Bar











Use the options on the Edit Bar, which displays above the Text Entry field, to change the font, size, and style of the text.

The Edit bar also displays in the drawing area above the Text object when you click the **Edit Text in Place**  edit button. See *Editing Text on page 510*.

Select the desired options before typing to affect the text as it is typed, or select some or all of the text and then specify which options to apply to it.

- Select a **Font** from the drop-down list.
- Specify the **Text Size** in drawing units.
- Click the **Print Size**  button to open the Printed Size Input dialog. See *Scaling Text on page 513*.
- Click the **Color**  button to specify the color of the selected or subsequently typed text. See *Color Chooser/Select Color Dialog on page 203*. If **Layer Color Text** is checked on the APPEARANCE panel, any custom colors specified here are lost. See *Appearance Panel on page 504*.
- Click the **Insert Hyperlink**  button to insert text that links to a web address or edit an existing selected hyperlink. See *Hyperlinks on page 499* and *Insert Hyperlink Dialog on page 502*, below.

Note: Hyperlink text is automatically underlined and assigned a non-default blue color. Once created, though, it is editable. To remove a hyperlink, select the linked text, right-click, and select Remove Hyperlink from the contextual menu.

- Click the **Bold**  button to specify the selected text as bold. The Ctrl+B hotkey can also be used.
- Click the **Italic**  button to specify the selected text as italic. The Ctrl+I hotkey can also be used.
- Click the **Underline**  button to specify the selected text as underlined. The Ctrl + U hotkey can also be used.
- Click the **Strikethrough**  button to specify the selected text as stricken-through.
- Click the **Uppercase**  button to display the selected text in all capital letters.
- Click the **Align Left** , **Align Center** , or **Align Right**  button to specify how the selected text is aligned.
- Click the **Paragraph Options**  button to specify the selected paragraph's alignment, spacing and bullets or numbering in the Paragraph Options dialog.
- Click the **Spell Check**  button to check the spelling in the selected text object. See *Spell Check on page 517*.
- Click the **Insert Macro**  button to place a Text Macro at the location of the cursor. Not available when multiple text objects are selected. User Defined macros are only available when the selected Rich Text object points to an eligible object using a Leader Line or Text Line with Arrow. See *Text Macros on page 540*.
- Specify the **Zoom** factor of the selected text by typing a percentage value in the text field or clicking the up/down arrows. This setting only affects the text as it appears in this dialog.

Note: Some fonts cannot be drawn at certain zoom factors. When this is the case, the appearance of the text will not change.

## 2 Text Entry Field

Type or paste text in the Text Entry field. See *Copy, Cut and Paste on page 514*.

- Depending on the current **Preferences**  settings, pressing the Enter key either forces a new line in the text box or closes the dialog. A carriage return can also be added by typing Shift + Enter or Ctrl + Enter. See *Text Panel on page 101*.

- Right-click in the Text Entry field to access a contextual menu from which you can select Undo, Redo, Cut, Copy, Paste, Spell Check and Select All. See *Contextual Menus on page 19*.
- To edit text in the entry field, click and drag to highlight any portion of it and then use the tools on the Edit Bar as needed.
- If the program identifies any spelling issues, they will be underlined in red.

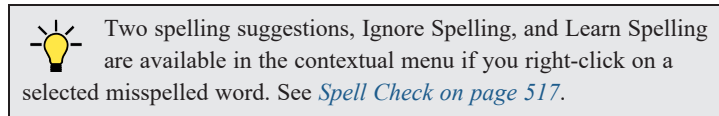

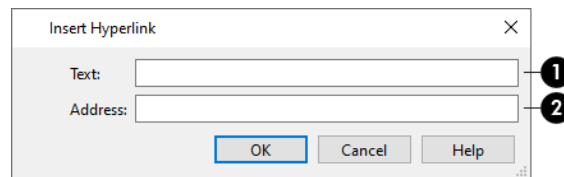

## INSERT HYPERLINK DIALOG

This dialog can also be accessed when adding Notes to an unlocked library item via the Details panel of the Library Browser. See *The Library Browser on page 946*.



### 1 Text

Specify the text of the hyperlink that the reader will see.

- If any text in the Rich Text Specification dialog is selected or if the cursor is located within an existing hyperlink when you click the **Insert Hyperlink**  button, it will populate the **Text** field. If you change this initial text, the selected text in the Rich Text Specification dialog will update when you click OK and return to that dialog.
- If no text is selected but the cursor is located within an existing hyperlink when you click the **Insert Hyperlink**  button, that hyperlink will essentially be selected: its text will populate the Text field and its address will populate the Address field.

### 2 Address

Specify the address, or URL, of the page that the link will access.

- If the **Address** field is empty when you click OK, the hyperlink will be removed.

## PARAGRAPH OPTIONS DIALOG

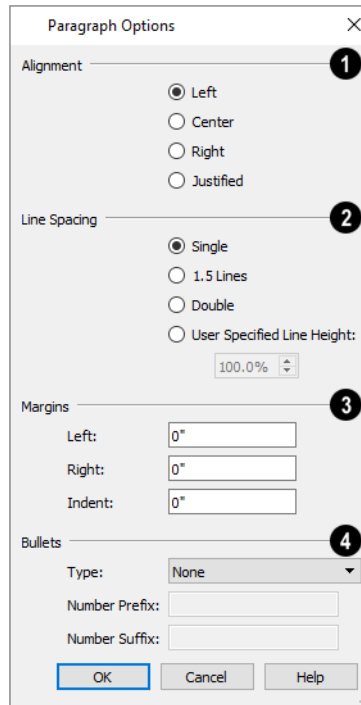

### 1 Alignment

Specify the **Alignment** of the selected paragraph(s). See *Aligning Text on page 513*.

### 2 Line Spacing

Specify the **Line Spacing** of the selected paragraph(s).

- Click the radio button beside **Single**, **1.5 Lines**, **Double** or **User Specified**.
- If you select **User Specified Line Height**, type the desired height in the text field. For best results, this value should be at least as much as the largest text size used in the selection.

### 3 Margins

Specify the appearance of the selection's side **Margins**, as measured in from edges of the text box. Only positive Margin values can be used.

- Specify the **Indent**, which is measured from the left side margin. A negative value can be used if a left Margin has been specified.



### 4 Bullets

Specify the appearance of **Bullets** and numbering in the selection.

- Select the desired bullet, numbered, or lettered **Type** from the drop-down list.
- Specify the **Number Prefix**, which are any characters that you would like to display before the number or letter. Does not affect paragraphs using circle or square bullets.

- Specify the **Number Suffix**, which are any characters that you would like to display after the number or letter and before its actual text. Does not affect paragraphs using circle or square bullets.

## APPEARANCE PANEL

**Leader Lines**  and **Text Lines with Arrows**  use the same default layer as Rich Text, so they share the same default color, line weight and line style. See *Layers on page 176*.

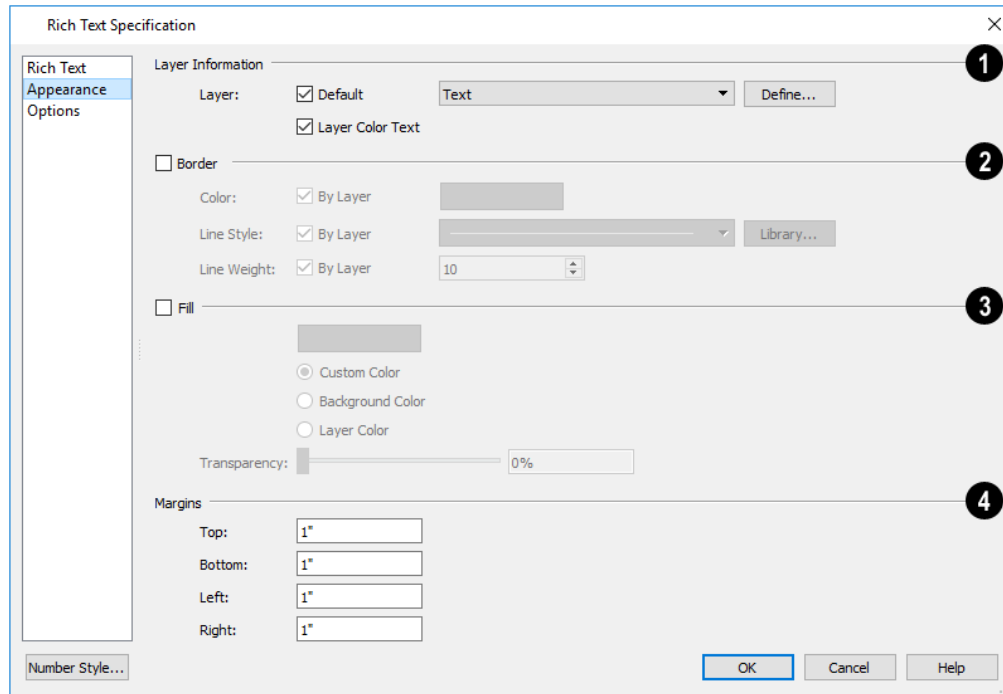

### 1 Layer Information

- Check **Default** to place the selected object on the default Text layer.
- Click the drop-down list to select from all layers available in the plan or layout file.
- Click **Define** to open the Layer Display Options dialog and select, modify, or add a new layer. See *Layer Display Options Dialog on page 179*.
- Check **Layer Color Text** to apply the color assigned to the selected Layer to the text on the TEXT panel. See *Text Panel on page 500*.

Note: If you change the color of some or all of the selected object's text, Layer Color Text will become unchecked. If it is checked again, the custom color(s) will be removed.

### 2 Border

Check **Border** to display a border around the selected text object and enable the settings that follow.

### 3 Fill

Check **Fill** to display a fill color within selected text object(s) and enable the settings that follow.



- Select **Custom Color** then click the Color bar to use a fill color of your choosing.
- Check **Use Layer Color** to use the color assigned to the text object’s layer as its fill color.
- Check **Use Background Color** to use program’s Background color as the text object’s fill color. See *Colors Panel on page 98*.
- Use the **Transparency** slider bar or text field to control how transparent the fill color is.

#### 4 Margins

Specify the **Top, Bottom, Left, and Right Margins**, which are the distance between the text and the border of the selected text object(s).

### OPTIONS PANEL

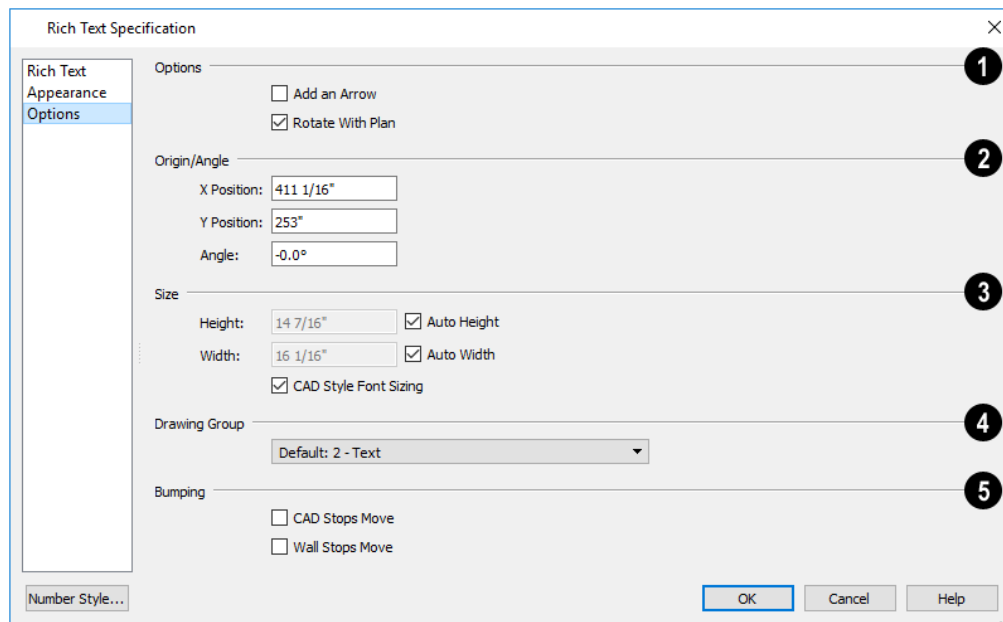

#### 1 Options

- Check **Add an Arrow** to add a Text Arrow to the selected text object. It will be attached to the left side of the selected object if the text is set to Align Left, or to the right side if it is set to Align Right or Align Center. See *Text Arrows on page 519*.
- Check **Rotate with Plan** to rotate the selected text when **Rotate Plan View**  is used. If unchecked, the selected text is unaffected when Rotate Plan View is used. See *Rotate Plan View on page 147*.

**Rotate with Plan** also affects text in views sent to layout if the layout box is rotated. See *CAD and Text in Layout on page 1337*.

- Specify the **Layout Page** that the selected object(s) is located on. Only available in layout files, but not in the Rich Text Defaults dialog in layout. See *Layout on page 1333*.

## 2 Origin/Angle

- Specify the **X Position** and **Y Position** of the selected object relative to the origin. See *3D Drafting on page 13*.
- Specify the **Angle** of the selected text object. The default value is 0°.

## 3 Size

Specify the **Size** of the selected text object.

- Specify the **Height** of the selected text object(s) or check **Auto Height** to automatically adjust the text object's height to match its contents.
- Specify the **Width** of the selected text object(s) or check **Auto Width** to automatically adjust the text objects width to match its contents. When Auto Width is used, text extends in a single line rather than wrap.
- **CAD Style Font Sizing** measures text size based on the total height of the capital letter A, as most CAD programs do. Uncheck this to instead size text according to information stored with the font, as most word processing programs do. See *Character Size on page 496*.

## 4 Drawing Group

See *Drawing Groups on page 190*.



## 5 Bumping

See *Bumping/Pushing on page 243*.

- Check **CAD Stops Move** to bump the selected object into other CAD or CAD-based objects as it is moved.
- Check **Wall Stops Move** to stop the selected object when it bumps into a wall.

---

# Text Specification Dialog

 The Text Specification dialog opens if you select the **Text**  tool and then click once in the drawing area. It will also open when you use the **Leader Line**  tool if **Create Rich Text** is unchecked in the Preferences dialog. See *Text Panel on page 101*.

You can also open this dialog by selecting one or more **Text** objects or Room Labels, then clicking the **Open Object** edit button. See *Editing Room Labels on page 423*.

The Text Specification dialog is similar to the Text Defaults dialog but affects the selected text object rather than all subsequently created text. Also, the name of the Saved Default being edited will display in the dialog box title bar. See *Text Defaults and Preferences on page 494*.

Note: Rich Text objects have a different specification dialog. See *Rich Text Specification Dialog on page 500*.

The Text Specification dialog has the following panels:

## TEXT PANEL

The settings on the TEXT panel allow you to type the selected Text object or Living Area Label's content. Text cannot be added to a selected room's label, however.

Note: If you do not type anything in the text field on this panel when creating a new object, no object will be created when you click OK. On the other hand, if you remove the text from an existing object and click OK, an empty text box will result.

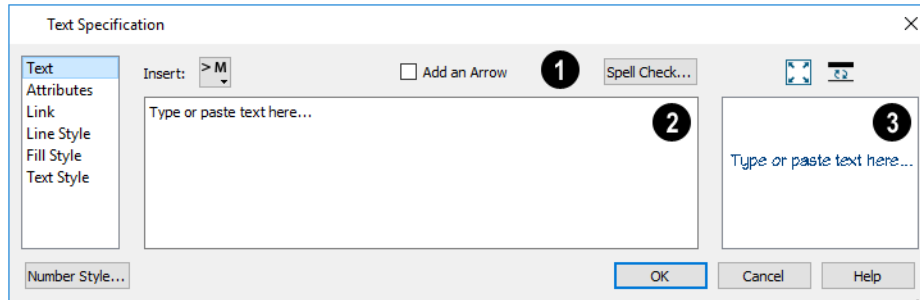

**1**

- Click **Insert** to choose from a list of special characters and text macros. User Defined macros are only available when the selected Rich Text object points to an eligible object using a Leader Line or Text Line with Arrow. See [Text Macros on page 540](#). Not available when the selected object is a Room Label. See [Room Labels on page 422](#).
- Check **Add an Arrow** to add a Text Line with Arrow to the selected text object. It will be attached to the left side of the selected object if the text is set to Align Left, or to the right side if it is set to Align Right or Align Center. See [Text Arrows on page 519](#).
- Click the **Spell Check** button to check the spelling of the text that displays in the **Text Entry** area. If Spell Check finds a word that may be spelled incorrectly, the Check Spelling dialog opens. See [Spell Check on page 517](#). Not available when multiple Text objects are selected.

**2 Text Entry**

- Enter text in the Text Entry field. This field is available for the Living Area but not for a selected room's label. See [Room Labels on page 422](#).
- Depending on the current **Preferences**  settings, pressing the Enter key either forces a new line in the text box or closes the dialog. A carriage return can also be added by typing Shift + Enter or Ctrl + Enter. See [Text Panel on page 101](#).
- Text automatically wraps to a new line without requiring a hard return.
- Tabs can be added to the text by pressing the Tab key.
- If the program identifies any spelling issues, they will be underlined in red.

 Two spelling suggestions, Ignore Spelling, and Learn Spelling are available in the contextual menu if you right-click on a selected misspelled word. See [Spell Check on page 517](#).

**3 Preview**

In the Text Specification dialog only, a preview of the selected text object displays on the right. Not available for Room Labels. See [Dialog Preview Panes on page 22](#).

## ATTRIBUTES PANEL

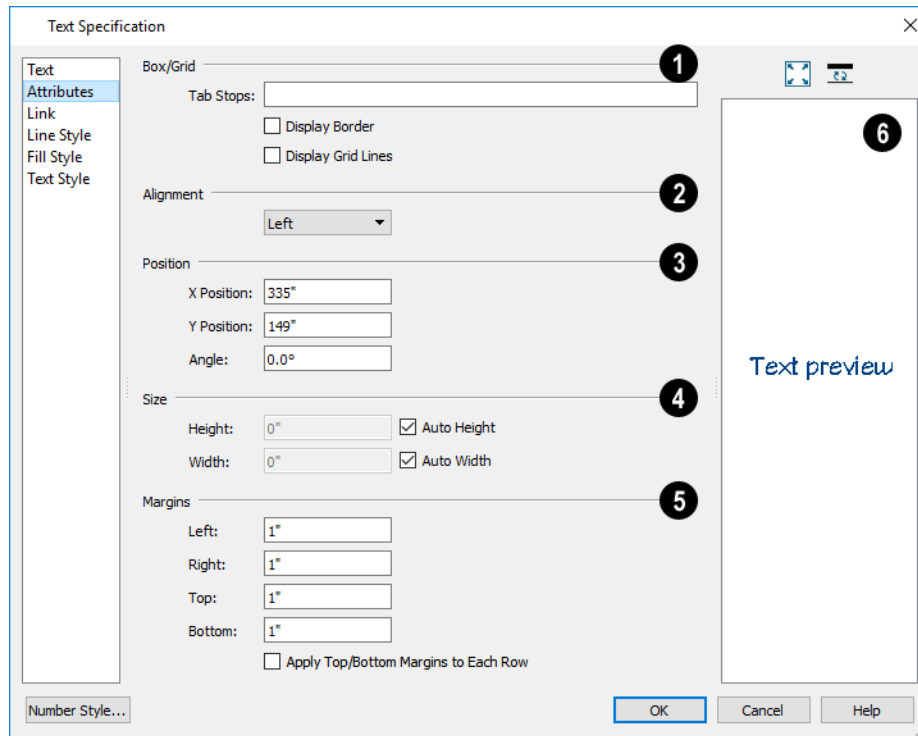

### 1 Box/Grid

- Specify the positions of the selected text object's **Tab Stops**.
- In the text field, specify the number of spaces from the left edge of the text box where each new column begins. The first column always starts at 0 and is not listed.
- Check **Display Border** to turn on the display of a border polyline around the selected object.
- Check **Display Grid Lines** to turn on the display of the grid formed by the specified rows and columns.

### 2 Alignment

- Select "Left", "Centered", "Right", or "Justified" from the drop-down list.

### 3 Origin/Angle

- Specify the **X Position** and **Y Position** of the selected object relative to the origin. See *3D Drafting on page 13*.
- Specify the **Angle** of the selected text object. The default value is 0°.

### 4 Size

- Specify the **Height** of the selected text object(s) or check **Auto Height** to automatically adjust its height to match its contents.

- Specify the **Width** to of the selected text object(s) or check **Auto Width** to automatically adjust its width to match its contents. When Auto Width is used, text extends in a single line rather than wrap.
- Specifying a Height and/or Width of 0 sizes the text box as small as the text within it allows without turning on the Automatic behavior.

## 5 Margins

- A default **Left** and **Right** margin is applied. **Top** and **Bottom** margins are measured relative to the line height and may not extend to the text box completely when given a value of 0.
- Check **Apply Top/Bottom Margins to Each Row** to apply the Top and Bottom Margins specified above to each line of text within the selected Text object. When unchecked, the Top and Bottom margins are applied to the Text object as a whole.

## 6 Preview

In the Text Specification dialog only, a preview of the selected text object displays on the right. Not available for Room Labels.

## LINK PANEL

Hyperlinks can be associated with web pages or files saved on your computer. If a selected Text object has a hyperlink specified, you can click the **Follow Hyperlink**  edit button to open the linked web page or file.

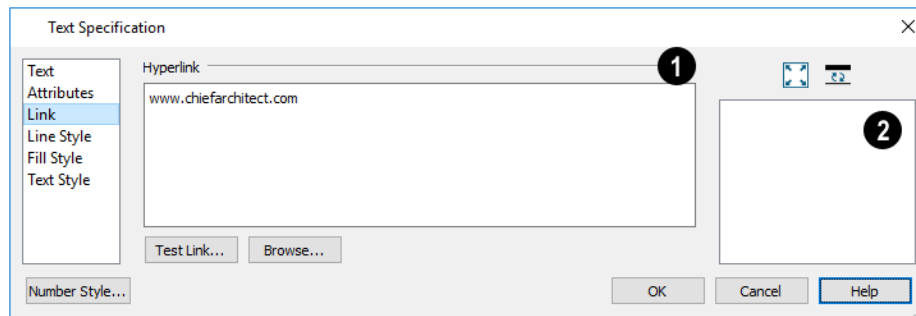

## 1 Hyperlink

Only one hyperlink can be specified for a single Text object. If more than one is added, none will work. See [Hyperlinks on page 499](#).

- Type a web page address or the pathname of a file on your computer in the text field. No additional text should be added.
- Click the **Browse** button to select a file on your computer and add its pathname to the text field above.
- Click the **Test Link** button to confirm that the address or pathname in the text field is associated with a web page or available file.

 Chief Architect automatically adds the http:// prefix for links that begin with "www" when Test Link is clicked.

## 2 Preview

A preview of the text entered on the TEXT panel displays on the right. Not available for Room Labels.

### ***To use a hyperlink***

1. Select the text object.
2. Click the **Follow Hyperlink**  edit button to activate the link.

### **LINE STYLE PANEL**

The LINE STYLE panel is found in the specification dialogs for many different objects. For more information, see [Line Style Panel on page 305](#).

### **FILL STYLE PANEL**

For information about the settings on this panel, see [Fill Style Panel and Dialogs on page 193](#).

### **TEXT STYLE PANEL**

The TEXT STYLE panel is available for a number of objects in the program and control the appearance of the selected object's text. See [Text Style Panel on page 538](#).

### **DIMENSION FORMAT PANEL**

The DIMENSION FORMAT panel is available in the Room Label Defaults dialog and allows you to control the format of the portion of the room label that describes the room's size. For information about these settings, see [Displayed Line Length Dialog on page 293](#).

---

## **Editing Text**

Once created, **Rich Text**  objects can be selected individually or as a group and edited using the edit handles, the Edit Toolbar buttons, and their specification dialogs. See [Rich Text Specification Dialog on page 500](#).

**Text**  objects can be selected and edited much the way Rich Text objects can; however, there are a few differences which are described here.



A customized text object can be added to the Library for future use. See [Add to Library on page 965](#).

Text objects can be edited using a variety of methods:

Callout and Marker editing are described separately. See [Editing Callouts on page 522](#) and [Editing Markers on page 529](#).

### **EDITING TEXT ATTRIBUTES**

Most text attributes, including the font, size, style, and the content itself, are edited in the Rich Text and Text Specification dialogs.

In order to edit the attributes of an existing **Rich Text** object, you must select some or all of the text before making changes. See [Text Panel on page 500](#).

**To edit Rich Text attributes**

1. Select a **Rich Text** object and click the **Open Object**  edit button.
2. On the **TEXT** panel of the Rich Text Specification dialog, click and drag to select some or all of the text typed into the Text field.

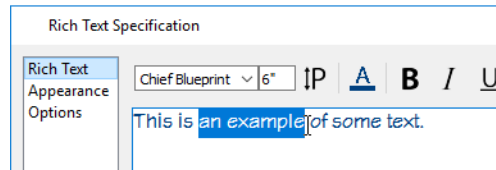

3. With some or all of the text selected, change any of the attributes available along the top of the panel, including the font, size, color, and style.

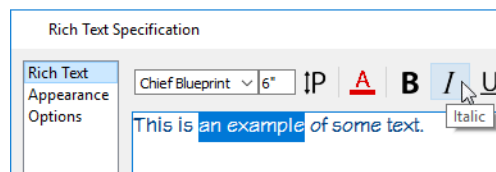

4. As changes are made, the selected text updates. Only the selected text is modified.

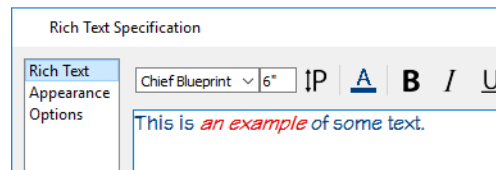

**Text** objects do not support multiple fonts or other attributes in the same text object. When you choose an attribute, it is applied to all characters in the text object.

**USING THE EDIT HANDLES**



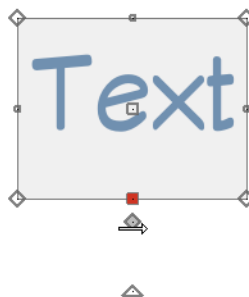

A selected **Rich Text** or **Text** object has the same edit handles as other box-based objects with one addition: the Add Text Line with Arrow handle.



Click and drag the diamond-shaped Add Text Line with Arrow handle in any direction to draw a Text Line with Arrow that is snapped to the selected text object at its tail end. You can also right-click and drag to draw multiple line segments. See *Text Arrows on page 519* and *To continuously draw by right-clicking on page 165*.

As a text box's width is made narrower or wider using an edit handle, its height may increase or decrease so that none of the text becomes hidden. The opposite is not true, however: a text box's height cannot be resized smaller than the height of the rows of text it currently contains, plus its margins.

Depending on the active **Edit Behavior** , the text box and the characters within it may or may not resize together when a corner edit handle is dragged. See *Defaults, Preferences, and Edit Behaviors on page 206*.

- If **Resize**  editing is enabled, both the text object and the font resize when a corner edit handle is dragged.
- If **Default**  or **Concentric**  editing is enabled, the text box resizes, but not the font size.
- If **Fillet**  editing is selecting, the corners become rounded and the font size does not change. See *Behaviors Panel on page 118*.

 When text is resized using the edit handles, there is a “sticky point” at the natural size of the text box. Hold down the Ctrl key while resizing to override this behavior.



## EDIT TEXT IN PLACE

**T** The contents and appearance of text objects created with the **Rich Text**  tool can be edited directly in the drawing area using the **Edit Text in Place** edit tool.

### To use Edit Text in Place



1. Select a **Rich Text** object and click the **Edit Text in Place**  edit button.
  - The text appears as it did when it was first created: inside a text field with the Edit Bar above. See *To create Rich Text on page 498*.
2. Click inside the Text Field to type or select any of the existing text.
3. Use the tools on the Edit Bar to edit any or all of the text as needed. The tools on the Edit bar are the same as those on the **TEXT** panel of the Text Specification dialog. See *Text Panel on page 500*.
4. When you are finished, click outside the text field to close it and the Edit Bar.

## CONVERT TO RICH TEXT

 **Text** objects cannot be edited to the same degree that Rich Text can. You can, however, convert a selected simple **Text** object to **Rich Text** by clicking the **Convert to Rich Text**  edit button. Most attributes of the selected simple **Text** object are retained; however, columns created using the Tab key are not. See *Tab Spacing on page 514*.

## USING THE EDIT TOOLS

A selected **Rich Text** or **Text** object can be edited in a variety of ways using the buttons on the Edit Toolbar. See *The Edit Toolbar on page 130*.

The **Match Properties**  and **Apply Properties**  tools can be used to apply selected attributes of a selected text object to other objects in the current view. See *Matching Properties on page 282*.

## RESIZING TEXT

Both the border of a text object and the characters it contains can be resized.

The border of a text object can be resized using its edit handles or by specifying the Height and Width in its specification dialog.



The default character height of **Rich Text** and **Text** objects can be specified as can the character height for individual objects, in their specification dialogs. See [Text Defaults and Preferences on page 494](#).

Character height can be measured in either of two ways. See [Character Size on page 496](#).

## SCALING TEXT

As with the size of other objects, text size is subject to the current drawing scale specified in the Page Setup dialog. See [Drawing Sheet Setup Dialog on page 1367](#).

To determine the **Height** in drawing units that is needed to produce text of a specific size when printed, use the Print Size Calculator dialog.

### To use the Print Size Calculator dialog

1. Select the text object or Text Style that you wish to scale and click:
  - The **Print Size**  button on the TEXT panel of the Rich Text Specification dialog. See [Text Panel on page 500](#).
  - The **Scale** button on the TEXT panel of a variety of specification dialogs. See [Text Style Panel on page 538](#).
  - The **Scale** button in the Text Style Defaults dialog.

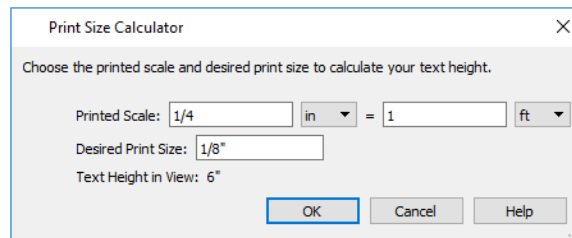





2. In the Print Size Calculator dialog:
  - Confirm the desired **Printed Scale**.
  - Enter the **Desired Print Size** of the text.
  - The **Text Height in View** required to produce the Desired Print Size displays here for reference.
3. Click OK to return to the previous dialog. The **Character Height** value now equals that of the Text Height in View.

Generally, the **Printed Scale** does not need to be changed in the Print Size Calculator dialog unless you intend to send the current view to layout at a different drawing scale. See [Sending Views to Layout on page 1338](#).

## ALIGNING TEXT

Text can be aligned in a number of ways.

- The text content of a text object can be aligned to the left, right, center or justified in the Rich Text Specification dialog. See [Text Panel on page 500](#).
- The text content of a text object can be also be aligned by clicking the **Align Left** , **Align Right** , **Center** , or **Justify**  edit button.
- The center points of text objects can be aligned with one another by assigning them the same **X** and/or **Y Position**. See [Attributes Panel on page 527](#).
- Text objects can be aligned by bumped them against a CAD line or CAD based object such as a roof plane. See [Bumping/Pushing on page 243](#).

A variety of other alignment methods are also available. See *Aligning Objects on page 246*.

The text in the columns of a schedule can also be aligned. See *Editing Schedules on page 685*.

## COPY, CUT AND PASTE

Copy, Cut and Paste of text into and out of the text specification dialogs can be accomplished using keyboard hotkeys:



- Press Ctrl + X to Cut the selected text and save it to the system clipboard.
- Press Ctrl + C to Copy the selected text and copy it to the system clipboard.
- Press Ctrl + V to paste your last cut or copied selection in a new text object.

For more, see *Copying and Pasting Objects on page 167*.

Copy, Cut and Paste use the system clipboard, making it possible to transfer text between text objects, between Chief Architect files, from a plan or layout into another application, or vice versa. See *Copying and Pasting Text on page 514*.

## TAB SPACING

The Tab key functions differently in **Rich Text** and **Text** objects:

- In **Rich Text** , the Tab key creates a space. CAD Style Font Sizing affects the size of the space created. See *Options Panel on page 505*.
- Tab spacing in **Text**  objects produces columns with widths that can be edited using edit handles.

### To insert tab-spaced text

1. Highlight a block of text objects containing tabs from another program or text from the Materials List and press Ctrl + C to copy them to the system clipboard.
2. Return to the plan view, select the **Text**  tool, and click to place a text object.
3. Press Ctrl + V to paste the copied materials into the text box, then click **OK**. The text object displays on-screen.
4. Select the text object and note the additional lines with handles separating each column.

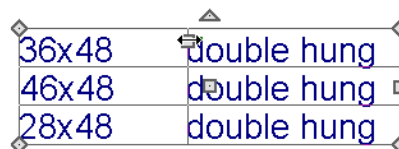

Columns automatically resize to fit the contained text. When a text object is selected, you can use the edit handles that display at each column to adjust spacing.

---

## Copying and Pasting Text

The Copy, Cut and Paste commands use the system clipboard, making it possible to transfer text between text objects, between Chief Architect files, from a plan or layout into another application such as a text editor or spreadsheet program, or vice versa. See *Copying and Pasting Objects on page 167*.

All or selected portions of the Materials List can also be copied and pasted into a text object, as well as into a word processing or spreadsheet program. See *Materials Lists on page 1303*.

Cut, Copy, and Paste can also be accessed from the Edit menu of many applications, including Chief Architect. These menu commands are not available when the text specification dialogs are open, but you can use the associated hotkeys.

### ***To Copy, Cut and Paste text***

1. On the **TEXT** panel of either text specification dialog or in another program altogether, highlight the text you wish to cut, copy or paste.
2. Press Ctrl + X to **Cut** the selected text out of its original location and save it to the system clipboard.
3. Press Ctrl + C to **Copy** the selected text to the system clipboard without removing it from its original location.
4. Open the text object or a file in another application and click to place your cursor in the Text field, writing area, or spreadsheet cell.
5. Press Ctrl + V to **Paste** the copied text at the location of your cursor.

Bear in mind that when text is copied and pasted, its formatting is not always retained. The results depend on the program or type of text object in which the content was created as well as the type of text object into which it is pasted.

### **PASTING INTO TEXT**

**T** Text pasted into a simple **Text** object from another source will not retain its formatting. Instead, the settings for that **Text**  object are always used. See *Text Specification Dialog on page 506*.

This is the case even if the text is copied from another **Text** object unless that object happens to use the same formatting.

Text pasted into a simple **Text** object from a spreadsheet program will retain basic column and row information. Each row can only have a single line of text; however, the width of each column can be adjusted. See *Tab Spacing on page 514*.

### **PASTING INTO RICH TEXT**

**T** Text pasted into a **Rich Text** object from another source, on the other hand, will retain most - but not necessarily all - of its custom formatting. If a line of text is sufficiently long, however, it may be wrapped automatically when pasted into Rich Text.

To retain the same character size when text is pasted from a word processing program into the Rich Text Specification dialog, uncheck **CAD Style Font Sizing**. See *Options Panel on page 505*.

If you want to retain the original color(s) of the text being pasted into a **Rich Text** object, be sure to uncheck **Layer Color Text** in the Rich Text Specification dialog. See *Appearance Panel on page 504*.

Text pasted into a **RichText** object from a spreadsheet program retains basic column and row information. Column width cannot be adjusted as it can in simple **Text** ; however, as you add or remove text from a cell, row height will increase or decrease to accommodate your changes.

### **PASTING INTO A VIEW**

Text can also be pasted directly into a plan view, CAD Detail, or cross section/elevation view. When you use the Paste command, a new Rich Text object is created, the text is pasted into that object, and it is selected. In order to see the new object, you may need to Fill Window.

## Find/Replace Text and Spell Check

**Find/Replace Text** and **Spell Check** locate text in Rich Text, Text, Callouts, Markers, CAD blocks, schedule titles and headings, Object Information, and custom labels for objects and rooms. They do not locate text in automatic object labels, default room labels, suppressed labels, the Materials List, or in the bodies of schedules, however.

**Find/Replace Text** and **Spell Check** locate text even when an object’s layer is turned off and/or locked. They can also find text in objects on locked layers. See *Locking Layers on page 178*.

### FIND/REPLACE TEXT

**A** **B** Select **Edit> Find/Replace Text** to find a particular word or string of text in your plan or layout file and replace it if you wish.

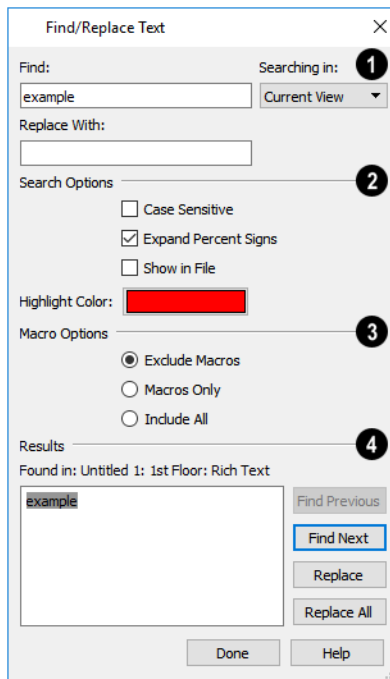

#### 1 Find and Replace

- Type the string of text that you want to **Find** in the text field.
- Type the string of text that you want the text you find to be **Replaced With**.
- Select the scope of your search from the **Searching In** drop-down list. Choose “Current View”, “Current File”, “All Open Files” or “Selected Objects”.

#### 2 Search Options

These settings allow you to refine your search.

- Check **Case Sensitive** to distinguish between capitalized and lowercase letters when searching. When unchecked, capitalization is ignored while searching. Regardless of whether this is checked, the capitalization used in the Replaced With field will be applied when text is replaced.

- When **Expand Percent Signs** is checked, the program will ignore strings of one or two % signs in a row, which may be used to mark up imported text with style commands. Uncheck this to find individual % signs in the search results.
- Check **Show in File** to open a new view window or go to a new layout page and highlight the object associated with the current search Result. When unchecked, the current search Result will only be highlighted if it is located in the current view window. See *Working in Multiple Views on page 150*.
- Click the **Highlight Color** button to specify the color used to highlight the object associated with the current search Result. This color is also used to identify misspelled words using the **Check Spelling** tool. See *Color Chooser/Select Color Dialog on page 203*.

### 3 Macro Options

These settings control whether macros are included in the search Results. The text of the actual Macro Names are searched: not their values or results. See *Text Macros on page 540*.

- Select **Exclude Macros** to ignore macros when searching.
- Select **Macros Only** to include macros and nothing else in the search Results, below.
- Select **Include All** to include both macros and regular text in the search Results.

### 4 Results

The current search Results are shown for reference in the field on the left. The location of the associated object, including file name, view name, and its object type is stated above the Results field as well. Click a button to the right of the Results field to perform the associated action:

- Click **Find Previous** to find the previous search Results.
- Click **Find Next** to search for additional Results.
- Click to **Replace** the current search Results with the replacement specified above.
- Click to **Replace All** instances of the current search Results found throughout the Searching In scope, selected above.

 Although the Find options do not locate text in suppressed labels, Replace All will replace that text. See *Displaying Labels on page 700*.

## SPELL CHECK

 Select **Tools> Checks> Spell Check** to open the Spell Check dialog. The **Spell Check** feature checks each text object in the current **.plan** or **.layout** file consecutively for spelling errors.

Spell Check can also be accessed by clicking the **Spell Check** button in the Rich Text, Text, Note, or Schedule Specification dialog or by clicking the **Spell Check**  edit button. When accessed in this manner, only the selected object is checked for spelling errors. See *Editing Text on page 510*.

## SPELL CHECK DIALOG

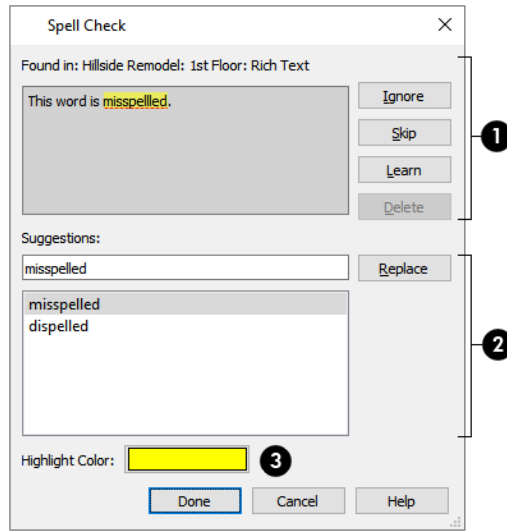

### 1 Results

Spell Check looks for each word in all open dictionaries. When a word that is not recognized is found, it displays here.

- The location that the spelling error was **Found in** is reported at the top of the dialog for reference.
- The text where the error was found displays in the top field for reference. The error itself is highlighted.
- Click **Ignore** to ignore the word in question in all Spell Checks during the current program session. The word will not be ignored the next time Chief Architect is launched.
- Click **Skip** to ignore the current instance of the word, but find other instances that may be present.
- Click **Learn** to add the word in question to the User Dictionary. See *Chief Architect Premier Data on page 37*.
- Click **Delete** to remove the selected word from the text.
- Click **Replace** to replace the word in question with the suggested word, below.

### 2 Suggestions

Spell check displays **Suggestions** for corrections here. There are two ways to replace a misspelled word:

- Type a correction in the field and click the **Replace** button.
- Click on a suggestion to select it, then click **Replace** to accept it.

### 3 Highlight Color

Click the Color bar to specify the **Highlight Color** for misspelled words when Check Spelling is used. This color is used to identify misspelled words in this dialog, text objects with misspelled words in views where an error is found, and text objects located using **Find/Replace Text**. See *Color Chooser/Select Color Dialog on page 203*.

When Spell Check is finished checking the text object or file for errors, the Spell Check results window displays.

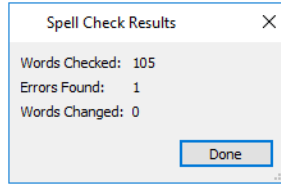

 Two spelling suggestions, Ignore Spelling, and Learn Spelling are available in the contextual menu if you right-click on a selected misspelled word in the Rich Text and Text Specification dialogs. See [Rich Text Specification Dialog on page 500](#).

## Text Arrows

Text arrows, which are simply CAD lines with arrows drawn on the “Text” layer, can be used to connect text objects to details of interest in your drawing. See [Line Tools on page 300](#).

There are several ways to create text arrows, and special snapping behaviors to take advantage of.

### LEADER LINE

 The **Leader Line** tool places either a Rich Text or a Text object with an arrow attached. This line with arrow can be selected and moved like any other line with arrow.

Note: Leader lines create Rich Text and have two leader line segments by default. You can change this in the Preferences dialog. See [Text Panel on page 101](#).

#### *To create text with a leader line*

1. Select **CAD> Text> Leader Line** .
2. Starting at the point where you want the arrow to point, drag to where you want a bend in the leader line and release the mouse button.
3. Click at the point where you want the center of the first line of text to display. The Rich Text Specification dialog opens. See [Rich Text Specification Dialog on page 500](#).
4. Enter text and click **OK**.

Alternatively, you can click in the same location twice without dragging to create a Rich Text object without a leader.

If multiple leader lines are specified, click in the same location twice to stop adding leader segments.

The initial alignment of text created with the **Leader Line** tool depends on the direction that the leader line was drawn:

- Leader lines drawn from left to right produce text that is right-aligned.
- Leader lines drawn from right to left produce text that is left-aligned.
- Leader lines drawn from vertically produce text that is center-aligned.

Leader lines inherit their default line style from the current defaults of the type of text associated with the Leader Line tool. If Leader Lines produce Rich Text, they derive their line style from the Border settings in the active Rich Text Defaults. If Leader Lines produce Text, they inherit the Line Style from the current Text Defaults. See [Appearance Panel on page 504](#) and [Text Specification Dialog on page 506](#).

They derive their default arrow style from active Arrow Defaults. See [Arrowheads on page 327](#).

## TEXT LINE WITH ARROW

 **Text Lines with Arrow** can be attached to text, CAD, and architectural objects by selecting **CAD> Text> Text Line with Arrow** and then clicking and dragging to draw a line. There is no limit to the number of text lines with arrows that can be attached to an object.

The endpoints of Text Lines with Arrow can be joined to form polylines with corners that can be adjusted using the edit handles. See [Polylines on page 316](#).

A **Text Line with Arrow** behaves like a **Line With Arrow**  with one exception: Text Lines with Arrow are initially placed on the default Text layer, not the Current CAD Layer. See [Layers on page 176](#).

## ADD TEXT LINE WITH ARROW EDIT HANDLE



Rich Text, Text, and Callout objects have a diamond-shaped Add Text Line with Arrow edit handle that you can click and drag in any direction to draw a Text Line with Arrow that is snapped to the selected object at its tail end. See [Using the Edit Handles on page 511](#) and [Editing Callouts on page 522](#).

## TEXT ARROWS AND SNAPPING

A CAD line, arc, spline, or open polyline with an arrow can be attached to other objects. It can attach to an architectural object anywhere within its 2D symbol in plan view, but attaches to a closed polyline-based object along its edges. A text line with arrow will automatically be deleted if one of the objects it is snapped to is deleted.

Text Lines with Arrow that have the same Line Style and Arrow attributes can be snapped together to form open or closed polylines. If two lines with arrows meet within the bounding box of a text object, however, they will not join. This allows you to attach multiple, separate text arrows to a single text object. See [Editing Line-Based Objects on page 216](#).

Text Lines with arrow can be independent or attached to other objects at both their tail and head ends. Arrows attach to closed polyline-based objects along their edges, but can attach to Text or an architectural object anywhere within its bounding box in plan view.

- When a selected Text Line with Arrow or Leader Line is snapped to an object on either end, its end edit handle will display the Selected Edge Handle Fill color. See [Colors Panel on page 98](#).
- If an attached object is moved, the end of the Text Line with Arrow will move, as well.
- When a selected text object is connected to another object using a Text Line with Arrow or Leader Line, a selection of Referenced Object macros that report information about that other object will be available to insert into the text. See [Text Macros on page 540](#).
- If a **Leader Line**  or **Text Line with Arrow**  is drawn with its tail end snapped to a text object or another Leader Line or Text Line with Arrow, it will be placed on the same layer as the text object and inherit all of that layer's attributes. Regular CAD lines with arrows do not do this. See [Layers on page 176](#).
- If a text arrow is attached to text or another object, deleting either the text or the object will also delete the text arrow.

## AUTO POSITION ARROWS

If either or both ends of a line with arrow are attached to an object, **Auto Position Tail** and **Auto Position Head** will be available in the Line Specification dialog. See [Arrowheads on page 327](#).

The Auto Position options are designed to prevent lines with arrows from crossing over the text or other objects that they are snapped to. These options snap the ends of a line with arrow to predefined points on the object(s) it is attached to. If an attached object is moved, the end of the line with arrow will update so that it is snapped to the closest Auto Position



location. Similarly, if the line with arrow is moved, rotated, or resized, its end may snap to a new Auto Position location on an attached object.

There are four Auto Position locations on a text object: one at the midpoint of each side. The Auto Position locations on other objects varies by object type.

The following image illustrates the behavior of Auto Positioning. The arrow has the **Auto Position Tail** option checked, and the tail end of the line is snapped to the text object. When the head of the line with arrow is moved, the tail of the arrow snaps to different Auto Position locations on the text object, maintaining its connection.

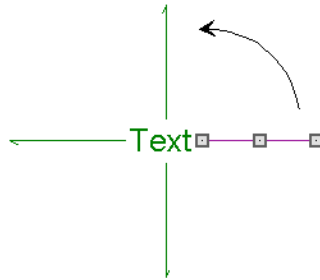

In addition:

- If a selected Text Line with Arrow is moved away from an Auto Position location and you check **Auto Position Tail**, the tail will snap to the nearest Auto Position location.
- The first segment of a polyline arrow attached to text maintains its angle when Auto Position is off and text is moved.
- Auto Position is disabled automatically when an arrow is not attached to one of the auto position locations.
- Arcs and splines with arrows can also be attached to text and other objects.

---

## Callouts

 To create a callout, select **CAD> Text> Callout**, then click at the location where you want a callout to be placed in plan view, a cross section/elevation view, a CAD Detail, or on a layout page. The Callout Specification dialog displays. Make any needed changes and click **OK** to place a callout. See *Callout Specification Dialog on page 526*.

Newly created callouts derive their attributes, including their shape and size, from the currently active Saved Callout Defaults. See *Multiple Saved Defaults on page 79*.

Callouts can be used to make connections between information on different pages of your construction documents. See *Linked Callouts on page 524*.

### CROSS SECTION LINES

Check the **Cross Section Line** box in the Callout Specification dialog to add a cross section line with the length, angle, and other attributes that you specify. See *Attributes Panel on page 527*.

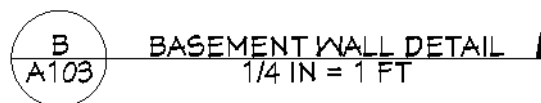

Callout with Cross Section Line and Section Arrow

Cross section lines can be added to any callout shape. You can specify the cross section line's length and angle in the Callout Specification dialog, as well as add text above and/or below the line. A cross section line can also be resized as well as rotated using the square edit handle located at the end of the cross section line. You can also add an arrow to the end of a cross section line that is perpendicular to the angle of that line. See *Editing Callouts on page 522*, below.

## CALLOUT ARROWS

To add an arrow or “hat” to a callout, select the callout and drag the diamond-shaped handle away from the center of the callout. An arrow is created, pointing in the direction you dragged. See *Editing Callouts on page 522*, below.

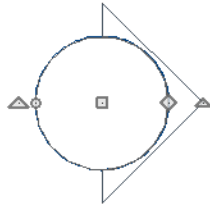

Arrows can also be specified in the Callout Specification dialog. See *Attributes Panel on page 527*.

You can also add as many CAD Lines with Arrows as you like to callouts. To add a line with arrow to a callout:

- Select the callout, then click and drag the diamond-shaped Add Text Line with Arrow edit handle located below the callout.
- Select **CAD> Text> Text Line with Arrow** , then click and drag to create a line with arrow, which can be moved or resized as needed.

See *Text Arrows on page 519*.

## DOUBLE CALLOUTS

Any callout can be specified as a **Double Callout** in the Callout Specification dialog. See *Attributes Panel on page 527*.



To resize the line between the two callout shapes, select the callout and then click and drag the edit handle at the center of either callout shape. The arrows on a double callout are always the same on both callouts.

## EDITING CALLOUTS

Callouts can be edited using the edit handles, the Edit Toolbar buttons and the Callout Specification dialog. See *Callout Specification Dialog on page 526*.

Layout view callout labels can also be edited using the edit handles and their specification dialog. See *Layout Box Borders and Labels on page 1345*.

When a callout or callout label is selected, it has a selection of edit handles. The number varies depending on whether the object in question is a regular callout or a callout label, as well as whether it has a cross section line and/or arrow.

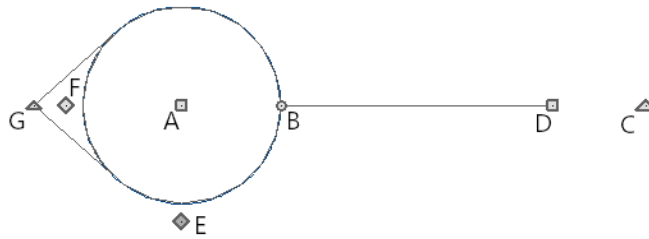

**A. Move**

- The **Move** handle is located at the center of the callout shape. Click and drag this handle to move the callout according to the currently active **Edit Behavior** .

**B. Concentric Resize**

- The small circular **Concentric Resize** handle displays on the perimeter of the callout shape. If the callout has a cross section line, it will be found where that line meets the perimeter. Click and drag this handle to resize the callout without moving its center point.
- If the callout's Size is set to **Automatic** in its specification dialog, any text displaying inside its shape will also resize when this edit handle is used. See [Note/Callout Panel on page 536](#).

**C. Rotate**

- The large triangular **Rotate** handle displays outside the callout shape perimeter, just past the end of the cross section line if one is present. It is used to rotate the callout shape. The callout's text does not rotate along with the shape unless the Text Angle is set to Automatic.

**D. Extend Cross Section Line**

- The square **Extend** handle is at the end of the cross section line, if there is one. Click and drag this handle to change the cross section line's length and/or angle.

**E. Add Text Line with Arrow**

- The diamond-shaped **Add Text Line with Arrow** handle is located below the callout shape. Click and drag this handle away from the callout shape in any direction to draw a Text Line with Arrow with its tail end snapped to either the callout center or the end of the cross section line and the arrow head end snapped to an object of your choosing. Not available for layout view callout labels.

**F. Add Callout Arrow**

- The diamond-shaped **Add Callout Arrow** handle is located just outside the callout shape. Click and drag this handle away from the callout shape in any direction to draw a callout arrow, or hat, to the perimeter. See [Callout Arrows on page 522](#).

**G. Rotate Callout Arrow**

- The small triangular **Add Callout Arrow** handle is located at the end of each callout arrow, or hat. Click and drag this handle to rotate that arrow around the callout shape.
- Remove an arrow by clicking and dragging this handle towards the center of the callout.

## Linked Callouts

 In construction documents, callouts are used to make connections between information on different pages. For example, a callout in a plan view can mark the location where the information in a detail drawing is relevant. That callout will include an identifier for the detail drawing and may also report the page where that drawing can be found. Meanwhile, a similar callout in or near the detail drawing will report its identifier along with the page with the plan view showing where its information is relevant.

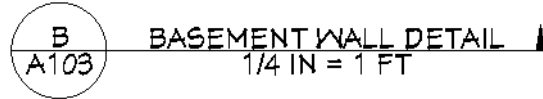

Callout with Cross Section Line and Section  
Arrow

In Chief Architect, you can add this information and help ensure that it stays current using Linked Callouts.

### CREATING LINKED CALLOUTS

To link a callout to a view or a layout page, select it and click the **Link View**  edit button. A selected callout can also be linked to a view or a layout page in its specification dialog. See [Link Panel on page 529](#).

There are several things you should do in order to use Linked Callouts:

- The file in which the callout is created must be saved. If it links to a view in a different file, that file must also be saved. See [Saving Plan and Layout Files on page 40](#).
- Set up your layout file to include Page Labels with a page numbering convention that meets your needs. See [Layout Page Information on page 1358](#).
- Create, save, and assign names to the views that you want to link using callouts:
  - [Plan Views on page 146](#)
  - [Cross Section/Elevation Views on page 1089](#)
  - [CAD Details on page 337](#)
- Send these views to layout. See [Sending Views to Layout on page 1338](#).
- Specify callouts for the layout box labels of section views and CAD Details sent to layout and link them to the page in layout where a plan view referencing them is found. See [Layout Box Specification Dialog on page 1349](#).
- Alternatively, you can add Callouts to section views and CAD Details themselves and link them to the page in layout where a plan view referencing them is found. See [Callouts on page 521](#).
- By default, cross section/elevation views are represented in plan view using a callout that has a label and - if the view is sent to layout, it will also report the layout page it was sent to. See [Camera Labels and Callouts on page 1098](#).
- CAD Details are not represented in plan view automatically, but you can add a Callout, link it to a CAD Detail view, and set it up to report that view's name and the layout page it was sent to.

By default, cross section/elevation views are represented in plan view using a round callout shape that has a label and - if the view is sent to layout, it will also report the layout page it was sent to.

CAD Details are not represented in plan view automatically, but you can place a Callout in plan view, link it to a CAD Detail view, and set it up to report that view's name and the layout page it was sent to.

You can also direct a camera view to report the layout page it is sent to using the `%layout_page_label%` macro.

## CAD DETAILS AND PLAN VIEWS

One application for linked callouts is creating an association between a detail drawing and a location in a plan view where that information is relevant.

### *To create a Linked Callout in plan view*

1. Select **CAD> Text> Callout** , then click to place a callout.
2. In the Callout Specification dialog, which opens next, go to the LINK panel, then:
  - Click the **Link** button.
  - If the current file is unsaved, you will be prompted to save it.
  - In the Link View dialog, expand the "CAD Details" folder under the current plan's file name, click on the name of the view you want to link to, and click OK.
3. On the CALLOUT panel of the Callout Specification dialog:
  - Click the **Insert** button to the right of the **Callout Label** field, mouse over "Object Specific", and select `%linked_view_name%`.
  - Click the **Insert** button to the right of the **Text Below Line** field, mouse over "Object Specific", and select `%linked_view_layout_page_label%`.
4. Click OK to create a Callout that reports the name of a CAD Detail as well as the layout page it was sent to.
5. If the CAD Detail in question has not been sent to layout, the Text Below Line will be blank. Open the CAD Detail view and send it to layout. See [Sending Views to Layout on page 1338](#).



When using Linked Callouts, consider assigning CAD Details names that consist of a single capital letter.

## LAYOUT BOX LABELS

Linked Callouts can also be used in layout box labels. See [Layout Box Borders and Labels on page 1345](#).

### *To create a Linked Callout layout box label*

1. If you have not done so already, open the plan view where the Linked Callout was created and send it to layout.
2. Go to the layout page where the CAD Detail was previously sent to layout, select its layout box, and click the **Open Object**  edit button.
3. On the LABEL panel of the Layout Box Specification dialog, select **Use Callout**, then click the associated **Edit** button.
4. On the CALLOUT panel of the Callout Label Specification dialog:
  - By default, the **Callout Label** uses the `%referenced_view_callout_label%` macro. This macro reports information for camera views, but not plan or CAD Detail views.
  - Delete the `%referenced_view_callout_label%` text and replace it with `%automatic_label%`, which reports the view's name.
5. On the ATTRIBUTES panel,

- The **Text Above Line** uses %automatic\_label% by default.
  - Delete the %automatic\_label% text and replace it with a short, descriptive name for the detail.
6. On the **LINK** panel, link the view to a layout page in the current file with a plan view where a Linked Callout references the selected detail:
- Click the **Link** button.
  - If the current file is unsaved, you will be prompted to save it.
  - In the Link View dialog, expand the Pages" folder under the current layout's file name, click on the page you want to link to, and click OK.

## MANAGING CALLOUT LINKS

There are a number of edit tools that help you manage a selected callout's link to a view or layout page.



**Link View** opens the Link View dialog, where you can link or relink the selected callout to a view. See [Link View Dialog on page 51](#)



**Unlink View** removes the link between the callout from the view it is currently linked to.



**Find in Layout** switches to the layout page that the selected callout is linked to, making it the active view.

If a callout's link to a view or layout page is broken, a Caution  symbol will display over the callout. Click on the Caution symbol to open a contextual menu where two additional options are available:

- **Refresh Link** confirms whether the callout's link is valid or invalid.
- **Ignore Invalid Links** to remove the Caution symbol from any callouts that have one and leave all callouts unchanged.

You can also add, change, or remove a callout's link to a view in the Callout Specification dialog. See [Link Panel on page 529](#).

If you want to relink all references to a particular plan file so they refer to equivalent views in a different plan, use the Referenced Plan Files dialog. See [Referenced Plan Files Dialog on page 52](#).

---

## Callout Specification Dialog



To open the Callout Specification dialog, select a Callout and click the **Open Object** edit button. This dialog also displays when a new Callout is created using the **Callout**  tool. See [Callouts on page 521](#).

The Callout Specification dialog is similar to Callout Label Specification dialog, which allows you to create callout labels for layout views. See [Layout Box Borders and Labels on page 1345](#).

This dialog is also similar to the Callout Defaults dialog but affects the selected callouts rather than all subsequently created callouts. Also, the name of the Saved Default being edited will display in the title bar of the defaults dialog. See [Text Defaults and Preferences on page 494](#).

### CALLOUT PANEL

For information about the settings on this panel, see [Note/Callout Panel on page 536](#).

## ATTRIBUTES PANEL

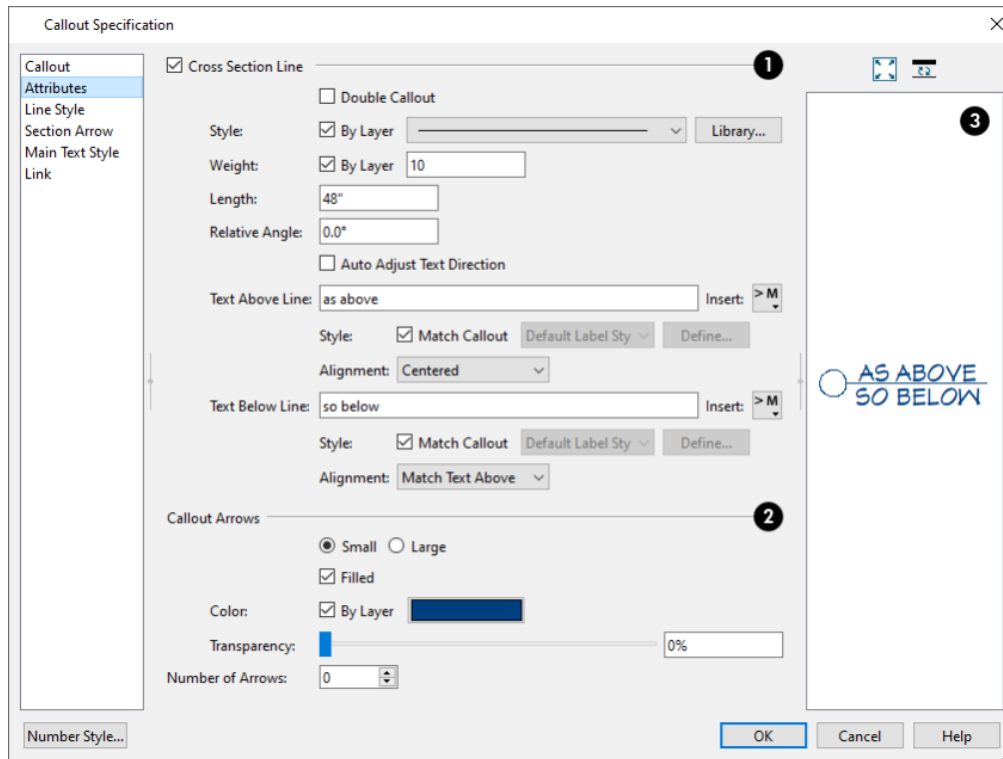

### 1 Cross Section Line

Check **Cross Section Line** to apply a cross section line to the selected callout and enable the settings that follow.

- Check **Double Callout** to specify two identical callouts connected by the cross section line. Only available when **Display** is checked.
- Select the cross section line's line **Style** from the drop-down list or by clicking the **Library** button. When **By Layer** is checked, the line style specified in the Layer Display Options dialog is used. See [Line Styles on page 199](#).
- Specify the **Weight** of the cross section line or check **By Layer** to use the line weight specified in the Layer Display Options dialog.
- Specify the **Length** of the cross section line.
- Specify the **Relative Angle** of the cross section line. This setting is not absolute: rather, it is measured relative to the Shape Angle of the callout object.
- When **Auto Adjust Text Direction** is checked, label text is oriented relative to the bottom or the right side of the view window, depending on the cross section line's angle. When unchecked, label text is oriented relative to the cross section line, regardless of its angle.
- Specify the **Text Above Line**, which is positioned above the cross section line.
- Click the **Insert** button to the right of the Text field to choose from a list of special characters and text macros. See [Text Macros on page 540](#).

- Specify the Text **Style** of the Text Above Line. When **Match Callout** is checked, the Text Above Line uses the Main Text Style used by the text inside the callout shape; uncheck this box to select a Text Style from the drop-down list or to click the **Define** button to open the Saved Text Styles dialog. See [Text Styles on page 538](#).
- Specify the **Alignment** of the Text Above Line: "Toward Callout", "Centered", or "Away from Callout".
- **Text Below Line** can also be specified, along with its Text Style and Alignment. These options are the same as for the Text Above Line with one exception: a "Match Text Above" Alignment option.

## 2 Callout Arrows

- Specify whether the arrows are **Small** or **Large**.
- Check **Filled** to specify arrows with a solid fill. When unchecked, arrows are unfilled.
- Specify the **Color** of the callout's arrow(s): check **By Layer** to use the color specified in the Layer Display Options dialog or click the Color bar to choose an arrow color. See [Color Chooser/Select Color Dialog on page 203](#).
- Use the **Transparency** slider or text field to control how transparent the callout arrow(s) are.
- Specify the **Number of Arrows**.
- The angle of each arrow can be set using the callout's edit handles. See [Editing Callouts on page 522](#).

## 3 Preview

A preview of the selected callout displays on the right. See [Dialog Preview Panes on page 22](#).

### LINE STYLE PANEL

The LINE STYLE panel is found in the specification dialogs for many different objects. For more information, see [Line Style Panel on page 305](#).

Additional attributes for the cross section line and arrows can be specified on the [Attributes Panel on page 527](#).

### SECTION ARROW PANEL

The settings on the SECTION ARROW panel are also found on the ARROW panel in the specification dialogs for a variety of different objects. For more information, see [Arrowheads on page 327](#).

If **Include Arrow** is available but unchecked and you check this box, Cross Section Line will become checked on the **Attributes** panel if it is not already. None of the settings on this panel are available when Double Callout is checked. See [Attributes Panel on page 527](#).

### MAIN TEXT STYLE PANEL

The settings on the MAIN TEXT STYLE panel control the appearance of the selected callout's Label and its Text Below Line, which can be specified on the CALLOUT panel. See [Note/Callout Panel on page 536](#).

The Text Style of the text above and below the cross section line, if present, can be specified on the [Attributes Panel on page 527](#).

For information about the settings on this panel, see [Text Style Panel on page 538](#).



## LINK PANEL

The settings on the LINK panel allow you to link the selected callout to a particular view and use text macros to report information about that view, such as its name, in the callout's text. See *Linked Callouts on page 524*.

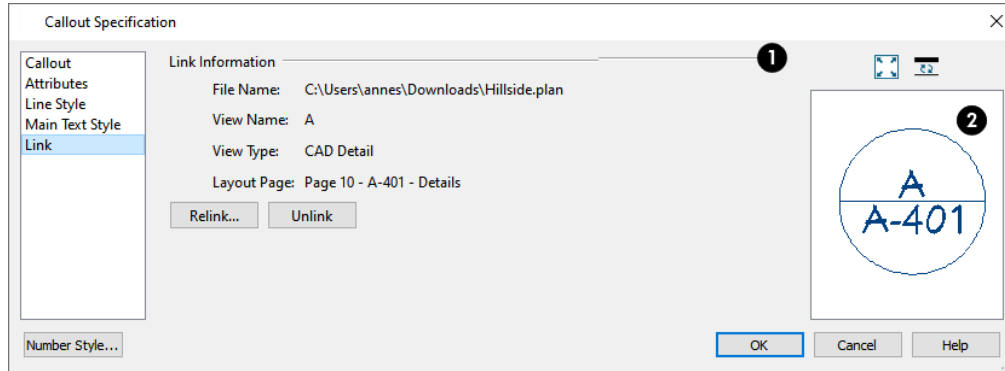

### 1 Link Information

The File Name, View Name, and View Type of the view currently linked to the selected callout are reported here, along with page number and page label of the view's linked Layout Page. See *Linked Callouts on page 524*.

- Click the **Link** button to create a link between the selected callout and a saved view or layout page in an open file, or click the **Relink** button to replace the existing link with a different one.
- Click the **Unlink** button to remove the existing link from the layout without replacing it.

### 2 Preview

A preview of the selected callout displays on the right. You can use macros to report information about a linked view in the Callout Label, Text Below Line, and in the text above and below the cross section line. See *Dialog Preview Panes on page 22*.

---

## Markers

 To create a marker, select **CAD> Text> Marker** and click at the location where you want it to be placed. The Marker Specification dialog opens. See *Marker Specification Dialog on page 531*.

Markers for **Level Lines**, **Test Borings** and **Point Markers** can be placed in plan view, cross section/elevation views, as well as CAD Details.

You can also place a framing reference marker using **Build> Framing> Framing Reference** . **Framing Reference Markers** should only be placed in plan views. See *Framing Reference Markers on page 875*.

## EDITING MARKERS

Markers can be edited using the edit handles, edit toolbar and Marker Specification dialog. See *Marker Specification Dialog on page 531*.

When a marker is selected, it has four edit handles.



**A. Move**

- The **Move** handle is located at the center of the callout shape. Click and drag this handle to move the callout according to the currently active **Edit Behavior** .

**B. Concentric Resize**

- The small circular **Concentric Resize** handle displays on the perimeter of the callout shape. If the callout has a cross section line, it will be found where that line meets the perimeter. Click and drag this handle to resize the callout without moving its center point.
- If the callout's Size is set to **Automatic** in its specification dialog, any text displaying inside its shape will also resize when this edit handle is used. See [Note/Callout Panel on page 536](#).

**C. Extend Cross Section Line**

- The square **Extend** handle is at the end of the cross section line, if there is one. Click and drag this handle to change the cross section line's length and/or angle.

**D. Rotate**

- The large triangular **Rotate** handle displays outside the callout shape perimeter, just past the end of the cross section line if one is present. It is used to rotate the callout shape. The callout's text does not rotate along with the shape unless the Text Angle is set to Automatic.

 A customized marker can be added to the Library for future use. See [Add to Library on page 965](#).

**POINT MARKERS AND DIMENSIONS**

There are a number of scenarios in which Markers may be created in conjunction with dimension lines. These Point Markers derive their initial attributes from the currently active Saved Marker Default and can be selected and edited:

- When the **Point to Point Dimension**  tool is used to draw a dimension line and an object is not available to snap to at either the start or end point, a Point Marker will be automatically created and the dimension line will locate it. See [Point to Point Dimensions on page 470](#).
- Dimensions drawn in a cross section/elevation view may locate Cross Section Lines that represent objects rather than the objects themselves. When this occurs, Point Markers will also be placed and the dimension lines will locate them. See [Cross Section Lines on page 1110](#).
- If a dimension line is copied independent of the objects it locates, the pasted dimension line will locate Point Markers. See [Copying and Pasting Dimension Lines on page 477](#).

In addition, **Auto Story Pole Dimensions**  and other vertically-oriented dimension lines in cross section/elevation views can display Elevation Markers along their extension lines. These markers are not individually editable but inherit their attributes, including marker Type, from the Saved Marker Defaults specified in the Dimension Line Specification dialog. See [Elevation Markers on page 475](#).

# Marker Specification Dialog

To open the Marker Specification dialog, select a marker and click the **Open Object** edit button.

This dialog also displays when a new marker is created by clicking in plan view using the **Marker**  tool.

The Marker Specification dialog is similar to the Marker Defaults dialog but affects the selected markers rather than all subsequently created markers. The name of the Saved Default being edited will display in the title bar of the defaults dialog. See *Text Defaults and Preferences on page 494*.

## MARKER PANEL

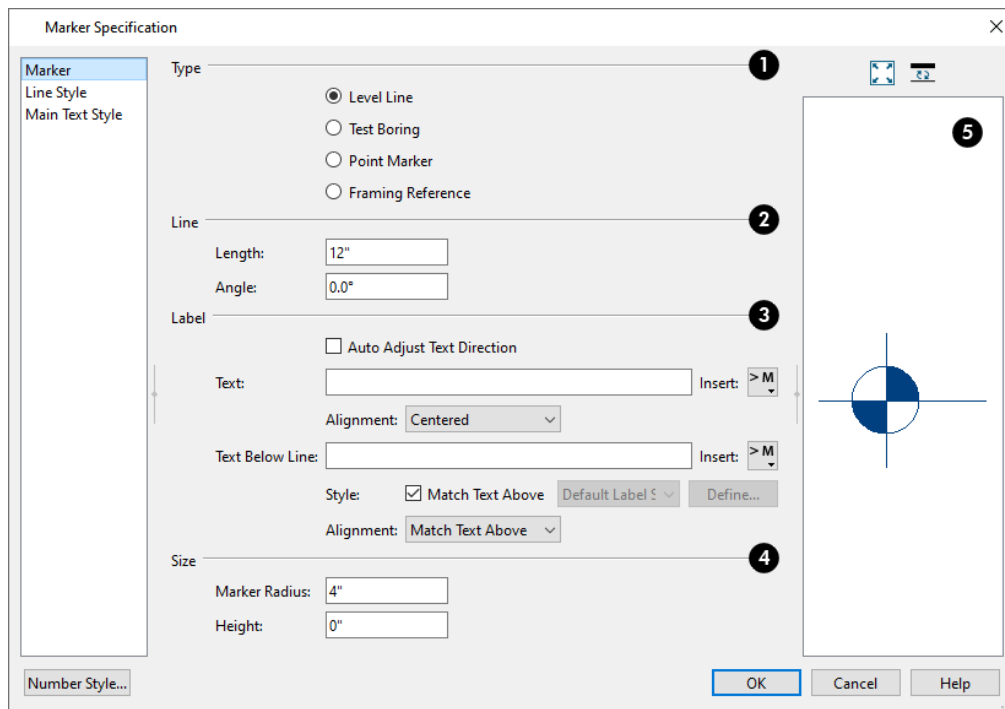

### 1 Type

Choose a marker **Type**. Note that **Framing Reference Markers**  affect the model, while the other marker types are for annotation only. See *Framing Reference Markers on page 875*.



## 2 Line

Specify the **Length** and **Angle** of the marker's line and text. For Test Boring and Point Markers, the Length controls the gap between marker and text.

## 3 Label

Specify the text and alignment of the selected marker's **Label**. The label's text style can be specified on the TEXT STYLE panel. See *Text Styles on page 538*.

- When **Auto Adjust Text Direction** is checked, label text is oriented relative to the bottom or the right side of the view window, depending on the cross section line's angle. When unchecked, label text is oriented relative to the cross section line, regardless of its angle.
- Type the **Text** which displays above the marker's line.
- Select a text **Alignment** option from the drop-down list. Only available for Level Line and Framing Reference markers.
- **Toward Marker** positions the text next to the marker shape.
- **Centered** centers the text along the length of the marker's line.
- **Away From Marker** positions the text at the end of the marker's line.

Text Below Line and the related settings below it are only available for Level Line markers.

- Type the **Text Below Line** that displays below the Level Line marker's line, if desired.
- Click the **Insert** button to the right of either Text option to choose from a list of special characters and text macros. See *Text Macros on page 540*.
- Specify the Text **Style** used by the Text Below Line:
- When **Match Text Above** is checked, the Text Below Line uses the same Text Style as the text above the line.
- Uncheck this box, then select a different Text Style from the drop-down list.
  - Select a text **Alignment** option for the Text Below Line from the drop-down list. "Match Text Above" is selected by default.

## 4 Size

Specify the **Size** of the selected marker.

- Specify the **Marker Radius**, which is the distance from the marker's center to the edge of its filled shape.
- In a cross section/elevation view, specify the **Height** of the marker, relative to 0. This setting is also available in plan view but does not affect the marker's position. This value will display in the Label when a height macro is entered in either Label text field. See *Detailing Cross Section/Elevation Views on page 1094*.

## 5 Preview

A preview of the selected marker displays on the right. See *Dialog Preview Panes on page 22*.

## LINE STYLE PANEL

The LINE STYLE panel is found in the specification dialogs for many different objects. For more information, see *Line Style Panel on page 305*.

Additional attributes for the cross section line and arrows can be specified on the ATTRIBUTES panel. See [Attributes Panel on page 527](#).

## TEXT STYLE PANEL

The settings on the TEXT STYLE panel control the appearance of the selected object's text. For more information, see [Text Style Panel on page 538](#).

---

# Notes, Note Types, and Note Schedules

**N** Notes are a special type of callout that link directly to a line item in a Note Schedule. Notes can be created for a variety of purposes, such as General Notes and Framing Notes. See [Note Type Management Dialog on page 534](#), below.

Notes are typically used in plan view but can also be created in CAD Details, cross section/elevation views, and camera views. Like other schedules, it is recommended that Note Schedules be placed in CAD Details; however, they can also be placed in plan and cross section/elevation views. See [CAD Details on page 337](#).

A Note created in plan view can be seen in camera views, and vice versa, provided that its layer is turned on. In contrast, a Note created in a cross section/elevation view only exists in that view. If the note's position in plan view puts it behind one or more surfaces in a camera view, it will be partially transparent.



Notes created in either plan or camera view can be included with exported Chief Architect 3D Viewer models. See [Export Chief Architect 3D Viewer File on page 1223](#).



Note callouts are created using the settings in the Note Defaults dialog. Once created, they can be edited much like standard Callouts. One exception is that standard Callouts can display arrows and cross section lines while Notes cannot. See [Editing Callouts on page 522](#).



A customized Note can be added to the Library for future use. See [Add to Library on page 965](#).

### **To create a note schedule with notes**

1. Select **CAD> Text> Note** , then click at the location where you want a note callout to be placed.
2. The Note Specification dialog opens automatically. On the NOTE panel:
  - Type the desired **Text** that you would like the new Note callout to be associated with in its Note Schedule.
  - Specify the **Type** of Note Schedule to associate the new Note with.
  - Notice that the **Label Text Above Line** uses the %simple\_schedule\_number% text macro by default. See [Text Macros on page 540](#).
3. Make any other needed changes, and click OK to place a Note callout. See [Note Specification Dialog on page 535](#).
4. The new Note callout is blank and has a Caution  symbol because it is not yet associated with a Note Schedule.
5. If you click on the Caution symbol, a contextual menu displays:
  - **Create Note Schedule from Note(s)**  creates a Note Schedule in the current view that reports information about the selected Note's Type.

- **Ignore Note With No Schedule** removes the Caution symbol from the selected Note and leaves it unlinked to a schedule.
  - **Ignore All Notes With No Schedule** removes the Caution symbol from all unlinked notes in the current view.
6. Select none of these and instead open a CAD Detail window and select **Tools> Schedules> Note Schedule** .
  7. Select the new schedule and click the **Open Object**  edit button.
  8. On the GENERAL panel of the Note Schedule Specification dialog:
    - Type the desired **Main Title** for the schedule.
    - Under **Objects to Include**, all Note Types that are currently present in the plan will be listed. Choose the Types that you wish to include in this schedule.
  9. Make any other needed changes to the schedule's settings and click OK. See *Schedule Specification Dialog on page 692*.
  10. Return to the view where you created the Note in step 1 and notice that the Note callout now displays a schedule row number.

## NOTE SCHEDULES



The **Note Schedule** tool allows you to produce customizable schedules that report information about Note objects created for a variety of purposes. See *The Schedule Tools on page 682*.

All Note Types present in the current plan are listed in the Schedule Specification dialog, under the **Categories to Include** heading. See *General Panel on page 692*.

By default, when a new Note Type is created, it will not be included in any existing schedules or in the Note Schedule Defaults automatically. You can specify which Note Types to include in a selected Note Schedule in the Schedule Specification dialog. See *General Panel on page 692*.



You can also create a Note Schedule in the current orthographic view by selecting one or more Note callouts and clicking the **Create Note Schedule from Note(s)** edit button. The resulting schedule will only report information about the selected Note Type(s). This edit tool is not available in camera views or overviews.

## NOTE TYPES

Note Types are used to indicate a unique purpose for each Note Schedule and to determine which Note objects each schedule lists.

Note Types are saved with each plan, so if you expect to use certain custom Note Types on a regular basis, you should add them to your plan template file(s). See *Template Files on page 87*.

Note Types can be exported from a plan file and then imported into other plans. Select **File> Export> Export Note Types** or **File> Import> Import Note Types**. They can also be imported and exported using the Note Type Management dialog. See *Importing Files on page 45* and *Exporting Files on page 41*.

## NOTE TYPE MANAGEMENT DIALOG



Select **CAD> Text> Note Type Management** to manage the various Note Types available in the current file.

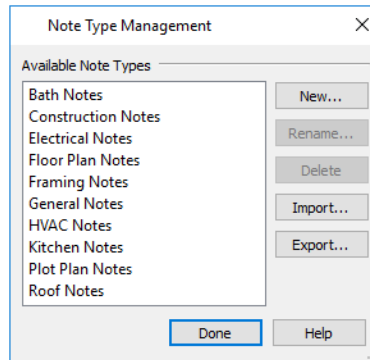

The **Available Note Types** in the current plan file are listed on the left. Click on a name to select it.

The buttons on the right let you manage the Note Types in the list.

- Click the **New** button to create a new Note Type. In the New Note Type dialog, type a short, descriptive, unique name for the new Note Type.
- Click the **Rename** button to open the Rename Note Type dialog and type a new name for the selected Note Type.
- Click the **Delete** button to remove the selected Note Type from the list. Only available when a custom Note Type is selected in the list.
- Click the **Import** button to import Note Types previously exported from another plan into the current file.
- Click the **Export** button to export the Note Types in the current file into a **.json** file so that they can be imported into other plan files.

You can specify a selected Note object's Note Type in the Note Specification dialog. See [Note/Callout Panel on page 536](#).

---

## Note Specification Dialog

**I** To open the Note Specification dialog, select a note callout and click the **Open Object** edit button. This dialog also displays when a new note callout is created using the **Note**  tool. See [Notes, Note Types, and Note Schedules on page 533](#).

The Note Specification dialog is similar to the Note Defaults dialog but affects the selected Note callout(s) rather than all subsequently created Notes. Also, the name of the Saved Default being edited will display in the title bar of the defaults dialog. See [Text Defaults and Preferences on page 494](#).

### NOTE PANEL

For information about the settings on this panel, see [Note/Callout Panel on page 536](#).

### LINE STYLE PANEL

The LINE STYLE panel is found in the specification dialogs for many different objects. For more information, see [Line Style Panel on page 305](#).

### TEXT STYLE PANEL

The settings on the TEXT STYLE panel control the appearance of the selected object's text. For more information, see [Text Style Panel on page 538](#).

## OBJECT INFORMATION PANEL

The information entered on the OBJECT INFORMATION panel can be used in Note Schedules. For more information, see *Object Information Panel on page 1331*.

## SCHEDULE PANEL

The settings on the SCHEDULE panel determine which schedule categories the selected Note is included in. See *Schedule Panel on page 704*.

# Note/Callout Panel

The NOTE panel is found in the Note Specification dialog, while the CALLOUT panel is found in the CALLOUT SPECIFICATION dialog. The NOTE and CALLOUT panels have numerous settings in common. See *Notes, Note Types, and Note Schedules on page 533* and *Callouts on page 521*.

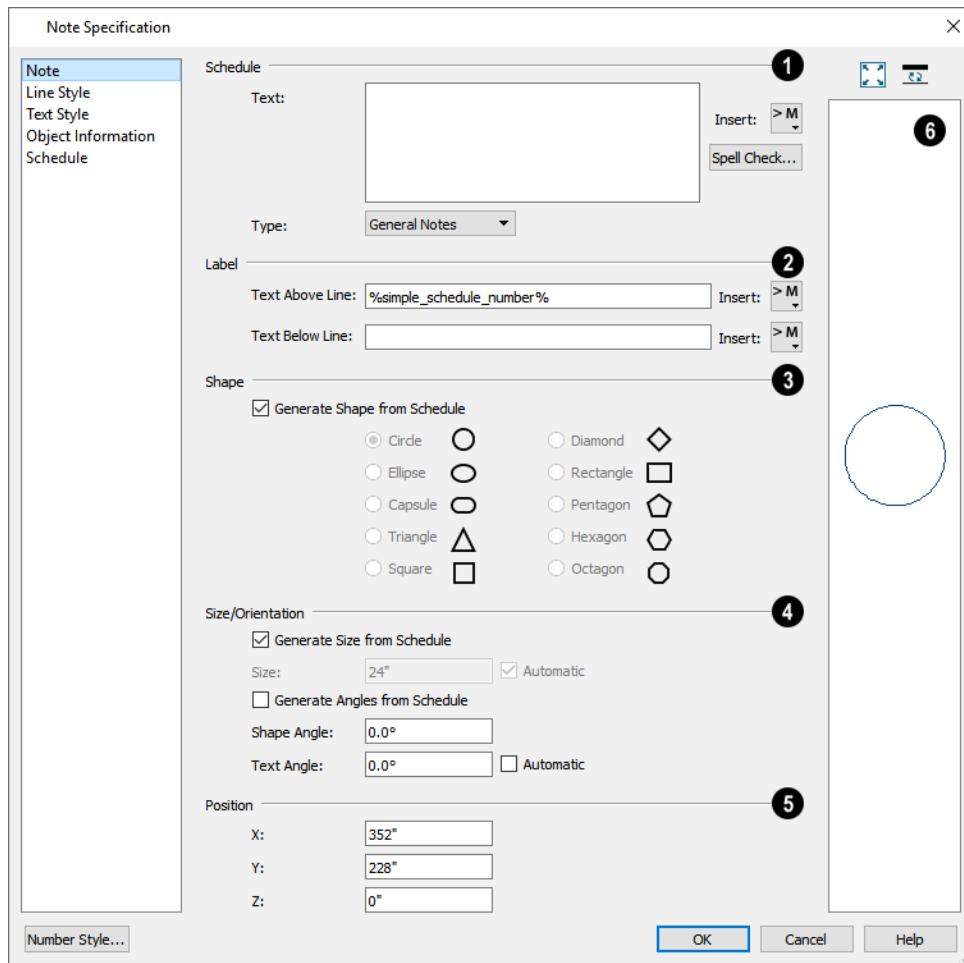

### 1 Schedule

The **Schedule** settings determine how and where the selected Note will be represented in a Note Schedule. These settings are not available for Callouts. See *Notes, Note Types, and Note Schedules on page 533*.



- Specify the **Text** associated with the selected Note that will display in the Note Schedule.
- Click the **Insert** button to the right of the Text field to choose from a list of special characters and text macros. See *Text Macros on page 540*.
- Click the **Spell Check** button to check the selected Note's Text for errors. See *Spell Check on page 517*.
- Specify the **Type** of Note Schedule to associate the selected Note with. See *Note Type Management Dialog on page 534*.
- Click the **New Note Type** button to create a new type to choose from. See *Note Types on page 534*.

## 2 Label

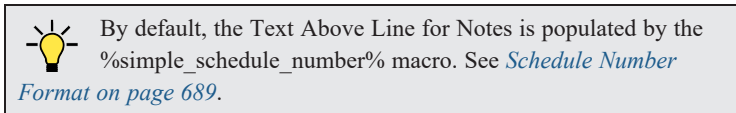

- Type the **Callout Label** or **Text Above Line**, which displays inside the callout shape. This text is centered in the callout shape when no Text Below Line is specified.
- Type the **Text Below Line** for the bottom row, if desired. If Text Below Line is added, a line centered in the callout shape will separate this text from the Text Above Line.
- Click the **Insert** button to the right of either option to choose from a list of special characters and text macros. See *Text Macros on page 540*.

## 3 Shape

- Check **Generate Shape from Schedule** to use the callout shape set in specification dialog of the Note Schedule associated with the selected Note. See *Labels Panel on page 697*.
- Select a callout shape by clicking the radio button beside one of the options.

## 4 Size/Orientation

- Check **Generate Size from Schedule** to set the Note's callout size based settings in the Note Schedule Specification dialog.
- Uncheck **Automatic** to enable the **Size** field and specify a new value. When checked, the callout is sized so that it encompasses its Label.
- When **Generate Angles from Schedule** is checked, you can specify the selected Note's shape below. Check this box to instead set the Note's Shape and Text Angles based on settings in the Note Schedule Specification dialog.
- Specify the **Shape Angle** of the callout shape. Does not affect the Ellipse, Capsule, or Rectangle shapes.
- Specify the **Text Angle** of the text inside the callout shape. Check **Automatic** for the Text Angle to match the Shape Angle.

## 5 Position

Specify the **X, Y, and Z Position** of the selected Note relative to the origin. These settings are not available for Callouts. See *3D Drafting on page 13*.

## 6 Preview

As in many specification dialogs, a preview of the selected object displays on the right. See *Dialog Preview Panes on page*

22.

Note: When the %simple\_schedule\_number% macro is used in a Note's Label, the schedule number it reports will not be shown in this preview.

---

## Text Styles

In Chief Architect, a Text Style is a saved set of attributes that can be assigned to any object that displays text, such as Text, Callouts, Markers, Dimensions, Schedules, CAD objects, and object labels. A given Text Style can be assigned to objects:

- By layer, in the Layer Display Options dialog;
- On the TEXT STYLE panel of various objects' defaults dialogs;
- On the TEXT STYLE panel of some individual objects' specification dialog.

This makes it easy to ensure that various objects display text with a consistent appearance.

Note: Because of its ability to use multiple attributes in the same object, Rich Text does not use Text Styles. See *Rich Text Specification Dialog on page 500*.

You can create your own or edit existing Text Styles to suit your needs in the Text Style Defaults dialog.

### TEXT STYLE DEFAULTS

 Select **Edit> Default Settings**, expand the Text, Callouts and Markers category, click on "Text Styles" and click the **Edit** button. The Saved Text Styles dialog will open, allowing you to select which Saved Text Style Defaults you would like to edit. See *Multiple Saved Defaults on page 79*.

The Text Style Defaults dialog can also be accessed:

- From the Layer Display Options dialog. See *Layer Display Options Dialog on page 179*.
- By clicking the **Text Style Defaults**  button, which can be added to your toolbars. See *To add a button to a toolbar on page 132*.
- By clicking the **Define** button on the TEXT STYLE panel of various objects specification dialogs.

### TEXT STYLE PANEL

 The TEXT STYLE panel is found in various specification and defaults dialogs in the program.

The settings on this panel are also found in the Text Style Defaults dialog, where they affect all objects using that style rather than a single selected object.

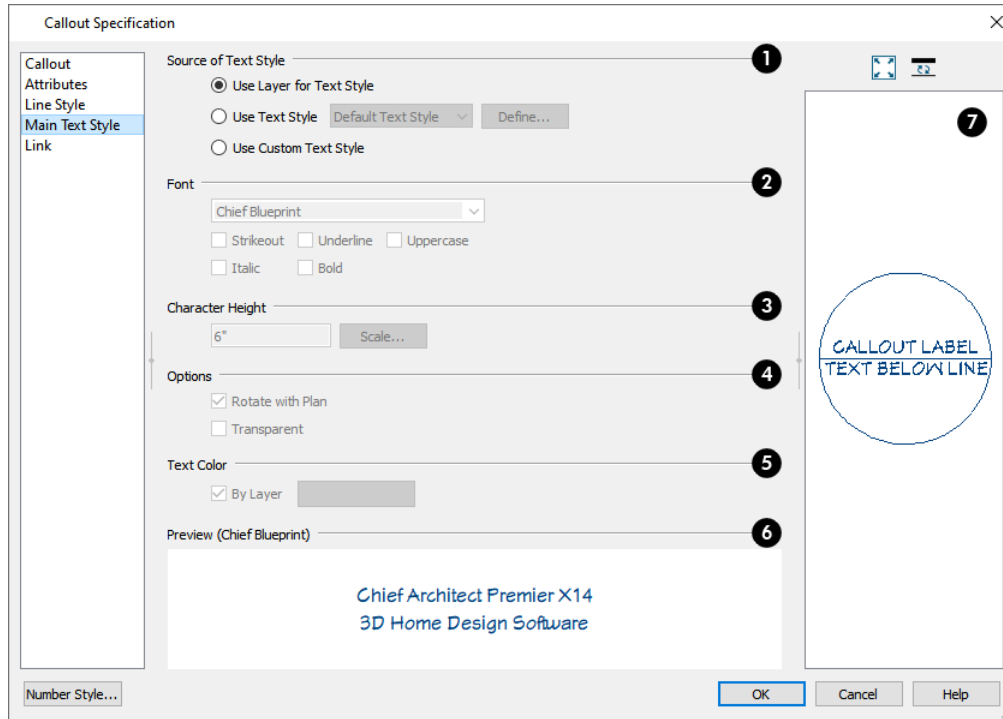

### 1 Source of Text Style

Specify where the selected object should draw its Text Style from. These options are not available in the Text Style Defaults dialog.

- Select **Use Layer for Text Style** to use the Text Style assigned to the layer that the selected text is located on.
- Select **Use Text Style**, then choose a style from the drop-down list to apply that style to the selected object, regardless of what layer it is on. When this is not selected, the name of the selected object's Text Style displays here for reference.
- Select **Use Custom Text Style** to enable the settings below and customize the selected objects Text Style attributes.
- Check **Use Default Text Style** to use the default style for the selected object type, or uncheck this box to enable the settings below and define a custom style.
- The settings that follow are only editable when **Use Custom Text Style** is selected. When it is not selected, information about the Text Style that is assigned to the selected object displays for reference.

### 2 Font

- Select a font from the drop-down list.
- The text styles **Bold**, **Underline**, **Italic**, **Strikeout**, and **Uppercase** are available. Check any of the boxes to apply that style.

### 3 Character Height

- Enter the **Character Height** in drawing units. This height is subject to the current drawing scale.
- Click the **Scale** button to open the Printed Size Input dialog. See *Scaling Text on page 513*.

- If the selected object was originally created in an older program version and had **Legacy Compatible Size** checked in that version, this check box will be available. If you uncheck the box and click OK, however, the option will be removed. See *Character Size on page 496*.

#### 4 Options

- Check **Rotate with Plan** to rotate text using the selected Text Style when **Rotate Plan View**  is used. If unchecked, the text is unaffected when **Rotate View** is used. See *Rotate Plan View on page 147*.

**Rotate with Plan** also affects text in a view sent to layout if the layout box is rotated. See *CAD and Text in Layout on page 1337*.

- Check **Transparent** to make text boxes using the selected Text Style transparent. When unchecked, text boxes have a solid fill the same color as your background color. Not available for objects that have FILL STYLE panels in their specification dialogs. See *Colors Panel on page 98*.

#### 5 Text Color

- When **By Layer** is checked, text uses the line color assigned to the layer that the object it is assigned to is located on. See *Layer Attributes on page 177*.
- Uncheck **By Layer**, then click the **Color** bar to select a different color. See *Color Chooser/Select Color Dialog on page 203*.

#### 6 Preview of Text Style

A preview of the Text Style currently assigned to the selected object displays here.

#### 7 Object Preview

In some specification dialogs, a preview of the selected object displays on the right. See *Dialog Preview Panes on page 22*.

---

## Text Macros

Text macros insert dynamic information relevant to the current plan or layout file, or a selected object. Macros can be used to create customized object labels and Materials List formulas. See *Creating User Defined Macros on page 1387*.

Macros can be inserted into Text objects as well as added to object labels, object information, and in the materials list.

There are four categories of insertable text macro:

- Global macros have information about the project, the plan or layout file, a room, and the date and time. They can also be used to insert special characters.
- User Defined macros can include a wide range of values, including global and object specific information and text. They can also be written to perform calculations. See *Creating User Defined Macros on page 1387*.
- Object Specific macros have information specific to a selected object type and can be included in object information and labels. See *Label Panel on page 700*.
- Some Object Specific and User Defined macros can also be inserted into Materials List cells and used to create custom Materials List formulas. See *Materials List Formulas on page 1320*.
- Referenced Object macros can be inserted into text objects that have an arrow attached to another object. These macros report information about that object rather than the text. See *Text Arrows on page 519* and *Referenced Object Context on page 1391*.

In layouts, macros can be used to add page numbers, drawing scale, and information to identify drawings can be inserted to improve organization and clarity.

### *To insert a macro*

1. The **Insert Macro**  button can be found on a variety of dialog panels where text can be specified.
2. When you click it, a menu of macros displays. Move your cursor over a menu item to view its submenu.
3. Select from the list of available macros. In this example **Global> Time Date> Short Date (%date.short%)** is used.

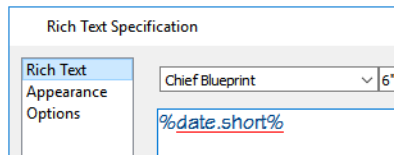

4. Depending on the context, some menu items may appear inactive; however, they can still be selected and inserted.
5. Click OK to close the dialog.
6. The text object displays the date rather than the macro formula.

11/9/17

As an alternative to creating and then inserting a custom macro, you can also type ruby macro code directly into a text object or label and it will be evaluated provided that it is placed between two percent signs.

## DESIGNER/CLIENT INFORMATION

 Information about the current project, the client it is drawn for, and the registered Chief Architect user working on the design can be inserted into text objects using macros. Some of this Designer and Client Information can also be included when exporting information to REScheck. See *Export to REScheck on page 1240*.

To specify what information these macros report by default in all plan and layout files, open the Default Designer/Client Information dialog, which can be accessed through the Preferences dialog. See *New Plans Panel on page 108*.

To specify what information these macros report in the current plan or layout file, select **Tools> Designer/Client Information** 

Designer/Client Information

Designer Information  
Client Information

Name:

Company Name:

Phone Number 1:

Phone Number 2:

Cell Phone Number:

Fax Number:

Web Site:

E-mail Address:

Street:

City:

State/Province:

Zip/Postal Code:

Country/Region:

Clear

OK Cancel Help

Information about the file's designer can be entered on the DESIGNER INFORMATION panel of the dialog, while information about the client can be entered on the CLIENT INFORMATION panel.

 When entering new Designer or Client Information, begin by clicking the Clear Form button.

---

# Doors

# Chapter 15



Chief Architect comes with tools for creating a wide variety of interior and exterior doors. In addition, the library offers a large selection of specialty doors and doorways including hinged, sliding, pocket, bifold, and garage doors. Additional name-brand door catalogs are also available for download from our website, [chiefarchitect.com](http://chiefarchitect.com).

## TOPICS

<b>Door Defaults</b> .....	<b>544</b>
<b>Door Tools</b> .....	<b>545</b>
<b>Displaying Doors</b> .....	<b>548</b>
<b>Editing Doors</b> .....	<b>551</b>
<b>Changing Door Swings</b> .....	<b>553</b>
<b>Special Doors</b> .....	<b>556</b>
<b>Door Specification Dialog</b> .....	<b>558</b>

## Door Defaults

There are several defaults dialogs for doors. Default Settings are accessed by selecting **Edit> Default Settings** . Click the arrow next to “Doors” to expand the category. Select a subheading and click the **Edit** button to open the defaults dialog associated with your selection:

Door Defaults can also be accessed by double-clicking the **Door Tools**  parent button or the **Hinged Door**  or **Sliding Door**  child button. Double-clicking the other Door Tools child buttons will open the defaults dialog for that particular door type.

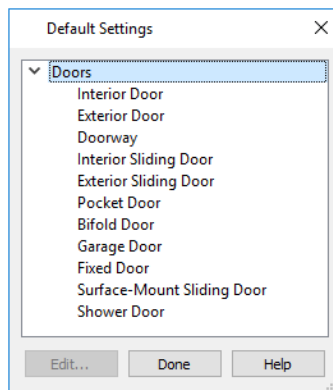

The various Door Defaults in the list can be multiple-selected by holding down the Shift or Ctrl keys. See [Shift and Ctrl Select on page 214](#).

The Door Defaults dialogs look nearly the same as the Door Specification dialog. See [Door Specification Dialog on page 558](#). There are only a couple of differences:

- Since default settings are specified here, “Use Default” is not an option for some settings as it is in the Door Specification dialog.
- The **Door Type** cannot be changed in the Defaults dialogs.

Because Hinged and Sliding Doors are often used in both interior and exterior applications, they have both Interior and Exterior Door Defaults.

### INTERIOR VS EXTERIOR DOORS

Regardless of its **Door Type** or the tool used to create it, a door will be:

- An Interior Door if it is created in a wall that separates two interior rooms;
- An Exterior Door if it is created in a wall that separates an interior room from either an exterior room or the building’s exterior. See [Room Types and Functions on page 415](#).

This rule does not apply to doors placed from the Library or copied and pasted from one location to another, however. If, for example, you place a hinged door in an interior wall between two rooms and then paste a copy of that door in an exterior wall, the copy will remain an interior door. See [Exterior and Interior Walls on page 351](#).



## DYNAMIC DOOR DEFAULTS

A variety of door default values are dynamic, including the Door Style, Casing, Lintel, Jamb, Hardware, Framing, and Rough Opening. When a dynamic default is changed, existing door using the default value are affected. See [Dynamic Defaults on page 79](#).

All Materials listed under “Doorway” on the MATERIALS panel are also dynamic. Materials assigned to doors and hardware items from the library, however, are listed separately and are dynamically linked to the “Interior Door”, “Exterior Door” and “Fixture Trim” and “Hardware” materials set in the Material Defaults dialog rather than the Door Defaults dialogs. See [Material Defaults Dialog on page 1051](#).

## DOOR FRAMING

The default headers, trimmers, rough opening, and sill for doors can be defined in the Door Defaults dialogs. You can also specify an additional amount to cutout for door openings in concrete garage curbs and foundation walls. See [Rough Opening Panel on page 572](#) and [Framing Panel on page 573](#).

The default header depths for different spans can be set in the Framing Defaults dialog. See [Openings Panel on page 865](#).

---

# Door Tools



To place a door, select the type you want from the **Build> Door** submenu. Move your mouse pointer over a wall section. When a preview outline can be seen, click to place a door at that location.

The minimum initial size for doors varies by Door Type. For example, If there is room enough along the wall to fit a 12” (300 mm) wide Hinged Door, a preview outline will display and a door can be placed. Garage doors, in contrast, must initially be at least 6’ (1800 mm) wide.

Doors can be placed in both straight and curved walls, as well as span across straight, collinear wall segments.

A newly created door inherits the settings in the Door Defaults dialog for its door type. Once created, doors can be edited in a variety of ways. See [Door Defaults on page 544](#).

Doors cannot be placed in a wall specified as Invisible or if the wall in question is on a locked layer. See [Locking Layers on page 178](#).

Once placed, any door may be changed into any other type of door in the Door Specification dialog. See [General Panel on page 559](#).

## HINGED DOORS

 Select **Build> Door> Hinged Door** and click on a wall to place a hinged door at that location. Hinged doors have separate defaults for interior and exterior doors. By default, a hinged door becomes a double door when its width is four feet (1200 mm) or greater.

The initial swing direction of a hinged door depends on the location of the mouse pointer relative to the wall when you click. The door will swing towards the side of the wall that you click nearest.

The initial hinge side of a hinged door can be set by clicking to place the door and then holding the mouse button down rather than releasing it. Move the mouse toward the end of the door that you would like the hinges to be on: as the mouse pointer nears either end, the door preview’s hinge side will move to that end. You can also adjust the door’s swing direction in this manner. When the swing direction and hinge side are correct, release the mouse button.

## DOORWAYS

 Select **Build> Door> Doorway** and click on a wall to place a doorway. Doorways are simply openings without a door and can be placed in interior and exterior walls, railings, and fences. You can assign a door from the library to a doorway if you wish.

## SLIDING DOORS

 Select **Build> Door> Sliding Door** and click on a wall to place a sliding door. Sliding doors have separate defaults for interior and exterior doors: interior sliding doors are typically solid while exterior sliding doors are Glass Panel doors.

The initial opening side of a sliding door can be specified by moving the mouse pointer along the wall while the mouse button is still pressed.

## POCKET DOORS

 Select **Build> Door> Pocket Door** and click on a wall where you want to place a pocket door.

As with sliding doors, the initial opening side of a pocket door can be specified by moving the mouse pointer along the wall while the mouse button is still pressed.

By default, a pocket door becomes a double pocket door if its width is four feet (1200 mm) or greater.

## BIFOLD DOORS

 Select **Build> Door> Bifold Door** and click on a wall where you want to place a bifold door.

Like a hinged door, the initial opening side of a bifold door depends on the location of the mouse pointer relative to the wall when you click. The door will open towards the side of the wall that you click nearest.

Similarly, the initial hinge side of a bifold door can be specified by moving the mouse pointer along the wall while the mouse button is still pressed.

By default, a bifold door becomes a double bifold if its width is greater than three feet (900 mm).

## GARAGE DOORS

 Select **Build> Door> Garage Door** and click on a wall to place a garage door.

In plan view, dashed lines show the size and location of the garage door when open.

Garage doors will build into a garage stem wall provided the room is designated as a garage before the door is inserted. See [Room Types and Functions on page 415](#).

## FIXED DOOR

 Select **Build> Door> Fixed Door** and click on a wall to place a fixed door.

## BARN DOOR

- ■ Select **Build> Door> Barn Door** and click on a wall to place a surface mounted sliding door, sometimes referred to as a barn style door.

## SHOWER DOOR

- ┌ Select **Build> Door> Shower Door** and click on a wall to place a hinged glass slab shower door.



Place a Shower Door in a Straight Glass Wall. See *Wall Tools on page 347*.

## THE DOORS & DOORWAYS LIBRARY CATALOG

 The Doors & Doorways library catalog can be accessed by selecting **View> Library Browser** and browsing to Chief Architect Core Catalogs> Architectural> Doors and Doorways. This catalog contains a variety of interior and exterior doors, as well as special entryways and wrapped openings.

Entryways and wrapped openings are examples of Doorways, which are wall openings that do not have doors within them.



To add a door to the Doorway, select a **Door Type** other than “Doorway” from the drop-down list in the Door Specification dialog. See *General Panel on page 559*.

You can also select a door from the library and place it into a doorway in plan view or any 3D view.

### ***To place a library door in a doorway***

1. Go to plan view or any 3D view.
2. Open the Library Browser.
3. Browse or search to find a door style that suits your needs.
4. Select the door in the Library Browser, then click on the doorway to place the selected door within it. If a door already exists, it is replaced.
5. Continue clicking other doorways as needed.

## CUSTOM DOORS AND DOORWAYS

You can import or create custom doors and doorways and save them in your own library for use in future plans. See *Symbol Objects on page 978*.

You can also specify the Door Type associated with a custom door symbol saved in the library in its Symbol Specification dialog. See *Options Panel on page 994*.

## Displaying Doors



The display of doors, door labels, opening indicators, header lines, and casing is controlled in the Layer Display Options dialog. See *Layer Display Options Dialog on page 179*.

Doors can only be placed in walls, so if a wall's layer is turned off in plan view, any doors placed in that wall will not display, either. Doors can display independent of their containing walls in 3D views, however. See *Displaying Walls on page 363*.

If the "Doors" layer is turned off, doors and their casing do not display but openings in the walls where they are located are visible.

Along with the doors themselves, the display of a number of door components can also be controlled by layer:

- Interior and exterior door casings are located on the "Casings, Exterior" and "Casings, Interior" layers and can display in all views. In plan view, the vertical side casings will be shown, but the horizontal top casing or lintel will not. If a door is recessed, the affected wall layers will adjust to accommodate the casing.
- Window and door shutters are located on the "Shutters" layer and can display in all views. Shutters can also be set to Show Closed or open. See *Shutters Panel on page 604*.
- When the "Opening Header Lines" layer is turned on in plan view, headers are represented by dashed lines within each door. These lines do not correspond to actual framing objects and cannot be selected. In addition, header framing members can be set to display. See *Wall Framing on page 852*.
- If a door is placed in a Garage room at a height where it extends into the stem wall or curb, a cutout in the concrete will display on the floor below. You can specify the cutout's size and whether it displays in plan view in the Door Specification dialog. See *Rough Opening Panel on page 572*.

### IN PLAN VIEWS

A door's jamb, casing, and swing are all represented in plan view. If a door is recessed, the affected wall layers will adjust to accommodate the casing.

A threshold line will display across a door opening in plan view when the door:

- Is located in an exterior wall. See *Exterior and Interior Walls on page 351*.
- Opens to an exterior room such as a Garage or Deck. See *Room Types and Functions on page 415*.
- Is located between rooms with different floor heights. See *Floor and Ceiling Platforms on page 428*.

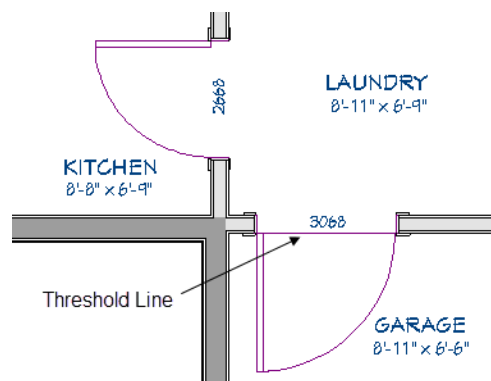

Doorways display dashed lines that represent the wall surface between the doorway and the ceiling. Other types of doors do not display these wall surface lines, however, you can specify that any door display them or not in its specification dialog. See [Options Panel on page 561](#).



If an exterior door to a Garage room on Floor 1 extends into a Garage stem wall or curb on Floor 0, its location will be indicated on Floor 0. You can control the display of this concrete cutout in the Door Specification dialog. See [Garages on page 716](#).

When the “Opening Header Lines” layer is turned on in plan view, headers are represented by dashed lines within each door’s opening. These lines do not correspond to actual framing objects and cannot be selected. In addition, header framing members can be set to display. See [Wall Framing on page 852](#).

The vertical casing on the sides of doors will display in plan view when the “Casings, Exterior” and “Casings, Interior” layers are turned on. See [Casing Panel on page 563](#).

### IN 3D VIEWS

In addition to the components drawn in plan views, door hardware and millwork display in camera views.

You can specify whether a selected door is shown open or closed in 3D views by clicking the **Show Door Open in 3D**  and **Show Door Closed in 3D**  edit buttons as well as in the Door Specification dialog. See [Options Panel on page 561](#).

If a door is set to display open in 3D, the angle of the open door can be changed using the edit handles in plan view. See [Using the Edit Handles on page 551](#).

You can specify whether an exterior door has a threshold in the Door Specification dialog. See [Casing Panel on page 563](#).

You can also specify whether window and door glass is opaque or transparent in the Rendering Technique Options dialog. When Opaque Window Glass is used, window and door glass uses the color specified for the active Rendering Technique. See [Rendering Technique Options on page 1153](#).

### OPENING INDICATORS

Doors, windows and cabinet doors can all display opening indicator arrows in Vector Views. See [Vector View on page 1150](#).

To display an object's opening indicator arrows in a Vector View:

- Turn on the “Opening Indicators” layer in the Layer Display Options dialog.
- Make sure the object is set to Show its opening indicators in its specification dialog. See [Opening Indicators Panel on page 570](#).

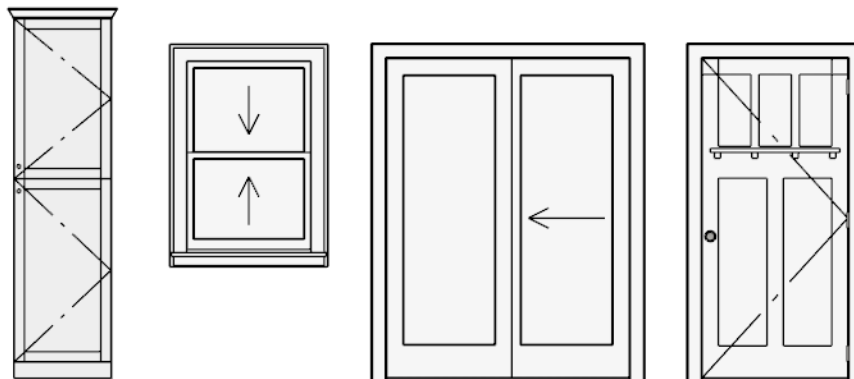

Opening indicators on a cabinet, window, and  
doors in a Vector View

You can specify whether opening indicators point to the opening hinge side or the opening side in the General Plan Defaults dialog. See [General Plan Defaults Dialog on page 92](#).

## DOOR LABELS

Door labels display in floor plan and cross section/elevation views, centered on the doors they represent, when the “Doors, Labels” layer is turned on and use the Text Style assigned to their layer. See [Label Panel on page 700](#).

Automatic door labels indicate Width and Height. For example:

- In U.S. Unit plans, the automatic label for a 3’-0” wide, 6’-8” high double hung window will read 3068.
- In metric plans, the automatic label for a 900 mm wide, 2100 mm high double hung window will read 900x2100.

If you prefer, you can use one of two other formats: Height/Width and Width Only. Label formats are specified in the Door Specification dialog or in the Door Defaults dialog if no schedule is present. See [Labels Panel on page 697](#).

Customized labels using text and Object Specific Text Macros as well as label position and orientation can also be specified in the Door Specification dialog. See [Text Macros on page 540](#).

## IN THE MATERIALS LIST

The materials associated with doors are listed under different Categories in the Materials List:

- **Doors** - Lists door panels, handles, and hinges.
- **Interior Trim** - Lists interior casing and lintels as well as interior door jambs.
- **Exterior Trim** - Lists exterior casing, lintels, shutters. Exterior jambs and thresholds are also listed here.

As with other objects, there are a number of ways to control how, or whether, doors are included in the Materials List. See [Organizing Materials Lists on page 1310](#).

You can add and edit information about a door’s accessories in the Door Specification dialog. See [Components Panel on page 1330](#).

## DOOR SCHEDULES



The **Door Schedule** tool is set up to produce customizable door schedules as well as door labels that display schedule numbers. Any schedule, however, can be set up to include doors. See [Schedules and Object Labels on page 681](#).

In addition, any information about door casing and lintels can also be included in any schedule set up to include items in the Room and/or Molding categories. See [Room Finish Schedules on page 447](#).

### *Hinge and Swing Side*



Hinge Side and Swing Side columns can be added to door schedules. See [Columns to Include on page 689](#).

There are various methods for describing hinge side as well as door swing direction, or door hand. In Chief Architect, both are described from the perspective of someone standing on the exterior side of the door.

- The hinge side will be described as L if the hinges are on the left side of the door, as viewed from its exterior side. If the hinges are on the right side, they will be described as R.
- The swing direction will be Out if the door swings towards the viewer on the exterior side.
- The swing direction will be In if the door swings away from the viewer, towards the interior.

Regardless of where they are located in a plan, all doors have an interior and an exterior side, as do the walls they are placed in. See [Interior and Exterior Surfaces on page 386](#).

## Editing Doors

Before a door can be edited, it must be selected. To select a door, click it when the **Select Objects**  tool or any of the **Door Tools**  are active. Doors and/or windows can also be group selected and edited. See [Selecting Objects on page 210](#).

Blocked units are made up of individual doors and windows that have been grouped together to act as one object. You can create a blocked door unit or by creating a **Mulled Unit**  composed of doors and/or windows. See [Mulled Units on page 583](#).

Select a blocked unit by clicking on it in any view. To select a door that is a component of a blocked unit, click at the location of the component in question, then click the **Select Next Object**  edit button. See [Selecting Objects on page 210](#).

### USING THE EDIT HANDLES

In plan view, click either of the two end handles and drag along the wall to change the width. The label showing the size updates as the handles are dragged. Click and drag the Move handle at the center to move the door along the wall it is placed in. Use the triangular Rotate handle to adjust the door's swing. If door labels are set to display, they will each have a small square Move edit handle and a small rectangular Rotate handle. See [Displaying Doors on page 548](#).

In 3D views, a selected door has five edit handles: the Move handle at the center and a Resize handle on each edge. Click and drag an edge handle to resize the door.

In cross section/elevation views, door labels will also display when their layer is turned on, and will have the same edit handles as in plan view.

Using the edit handles, doors resize according to the currently active **Edit Behavior** . See [Defaults, Preferences, and Edit Behaviors on page 206](#).

A door or window moved against an intersecting wall temporarily stops when the casing meets the intersecting wall. You can continue to drag and it resumes movement past the intersecting wall.

### IN THE SPECIFICATION DIALOG

The most precise method of editing a door or group of doors is to use the Door Specification dialog. Door type, size, casing, materials, shape, and more can all be specified in this dialog. See [Door Specification Dialog on page 558](#).

You can use the **Object Painter**  tools to assign the properties of one door to other doors. See [Matching Properties on page 282](#).

You can also apply a variety of door attributes to multiple doors at once using **Style Palettes**. See [Style Palettes on page 279](#).

### USING THE EDIT TOOLS

A selected door or doors can be edited in a variety of ways using the buttons on the Edit Toolbar. See [The Edit Toolbar on page 130](#).



**Change Opening/Hinge Side** changes the side of the door that its hinges are on. See [Changing Door Swings on page 553](#).



**Change Swing Side** changes which direction the selected door swings.



**Show Door Open in 3D** or **Show Door Closed in 3D** controls the selected door's appearance in 3D views. See *In 3D Views on page 549*.



**Gable Over Door/Window** creates a gable over the selected door(s) the next time the roof is rebuilt. See *Gable/Roof Lines on page 830*.



**Make Mullered Unit** can be used to block multiple selected doors and/or windows into a single unit, while **Explode Mullered Unit** breaks a mullered unit into its individual components. See *Mullered Units on page 583*.

## USING DIMENSIONS



Like various other objects, doors can be moved using dimensions. See *Moving Objects Using Dimensions on page 483*.

You can specify how doors and windows are located by dimensions in the Dimension Defaults dialog. Dimensions can be set to locate the centers, sides, casing, and/or rough openings of doors and windows, or you can choose to not locate them at all. See *Locate Manual Panel on page 454*.

Once a dimension line has been drawn, you can move or add its extension lines to locate non-default locations on a door. See *Editing Extension Lines on page 478*.

## CENTERING DOORS



The **Center Object** edit button allows you to center a selected door along a wall within a room or relative to a cabinet or window. See *Center Object on page 250*.

### *To center a door along a wall*

1. Select a door or combination of windows and doors in plan view.
2. Click the **Center Object**  edit button then choose from one of the following options:
  - Click near a wall inside a room to center the door along that wall in that room.
  - Click outside the house (on the exterior room) near an exterior wall to center the door along an exterior wall.

## DOOR STYLE AND PANELS

There are a number of Door Styles available for use, including Slab, basic Panel, and Louvered. In addition, a selection of door panel symbols is available in the Library. See *Placing Library Objects on page 972*.

By default, most door types are either single or double, depending on their width. You can specify how many panels a selected door has in the Door Specification dialog. See *Options Panel on page 561*.

## DOOR SIDES

Like walls, all doors have two sides: an interior side and an exterior side. This is the case even for doors placed in interior walls. See *Exterior and Interior Walls on page 351*.

By default, the interior side of the door will face the direction that the door swings to open. If you prefer, you can specify that the interior side face the opposite direction in the Door Specification dialog. See *General Panel on page 559*.

You can specify the materials for the two sides separately in the Door Specification dialog. See *Materials Panel on page 575*.



You can also specify different casing for the interior and exterior sides of exterior doors - that is, doors placed in exterior walls or walls defining a Garage or other exterior room type. See [Room Types and Functions on page 415](#).

## DOOR CASING

Doors typically feature casing, or trim, on both sides of the wall opening. See [Moldings // Profiles / Rails / Panels on page 927](#).

- By default, interior doors use the same casing profile on both sides. You can specify that both sides be edited separately in the Door Specification dialog. See [General Panel on page 559](#).
- Exterior doors can have different casing profiles on their interior and exterior sides.

The default casing for interior and exterior doors is a basic rectangular stock profile. You can specify a door's casing profiles in the Door Specification dialog, or you can choose to suppress casing altogether. See [Casing Panel on page 563](#).

A separate molding profile can be specified for the lintel, or top horizontal molding. See [Lintel Panel on page 565](#).

Exterior and interior door casing will display in all views when the “Casings, Exterior” and “Casings, Interior” layers are turned on. In plan view, only the vertical side casing is shown.

## DOOR HARDWARE

Handles, locks, and hinges can be assigned to a door in the Door Specification dialog. See [Hardware Panel on page 569](#).

In 3D views, handles and locks can also be applied directly from the Library Browser. Select a hardware item in the library, then click on the door to apply it to that side of the door. See [Inserted Objects on page 973](#).

---

# Changing Door Swings



Door swing direction and hinge side can be changed using the edit handles and the **Change Opening/Hinge Side** and **Change Swing Side** edit buttons.

Swing and hinge side can also be applied from one door to another using the **Match Properties**  tool. See [Matching Properties on page 282](#).

Note: If the door is set to draw closed, the swing as it appears in plan view has no effect on the 3D view. See [Options Panel on page 561](#).

The **Change Opening/Hinge Side**  edit button is available for all doors except doors with multiple panels and garage doors.

The **Change Swing Side**  edit button is available for all doors except pocket doors.

## HINGED DOORS

In addition to using the edit buttons, Hinged Doors and Shower Doors' hinge side and swing direction can be changed using the triangular Rotate edit handle.

### **To adjust the angle of swing:**

1. In plan view, select the door and grab the triangular handle.
2. Drag to change the amount of swing.

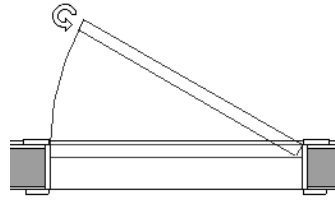

3. Release the mouse.

If you drag near the closed position, the door snaps to a closed position.

**To change the swing using edit handles:**

1. In plan view, select the door and grab the triangular edit handle.

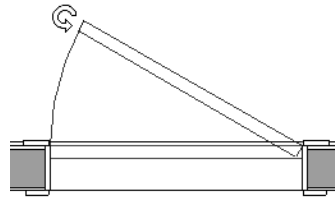

2. Drag the pointer along the path of the new arc to change the hinge side and/or swing direction.

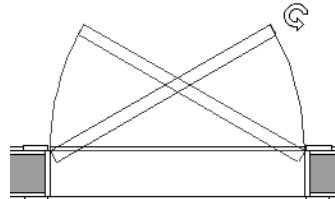

3. Release the mouse.

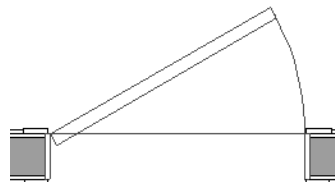

 You can specify a Double Hinged Door to swing from its center in the Door Specification dialog. See [Options Panel on page 561](#).

**To change the swing using edit buttons:**

1. In plan view, select the door.
2. To change the hinge side, click the **Change Opening/Hinge Side**  edit button.

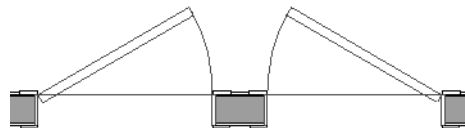

3. To change the swing direction, click the **Change Swing Side**  edit button.

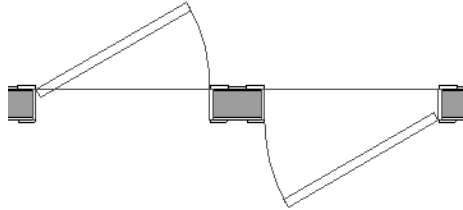

 You can also specify a Hinged Door to swing in both directions in the Door Specification dialog. See [Options Panel on page 561](#).

### SLIDING TYPE DOORS

Sliding, Pocket, Bifold, and Barn Doors are types of sliding door.

Similar to hinged doors, the Opening/Hinge and Swing sides of a Sliding, Pocket, Bifold, or Barn Door can be changed by clicking and dragging its diamond-shaped edit handle.

To change the side of a Sliding, Pocket, Bifold or Barn door that opens, select the door and click the **Change Opening/Hinge Side**  edit button.



Note: For a Pocket Door to change Opening Side, there must be enough room for the entire door to fit in the wall on that side.

To flip the fixed and moving sides of the door, click the **Change Swing Side**  edit button.



### GARAGE DOORS

To change the side of a garage door that it faces, select it and click the **Change Swing Side**  edit button.

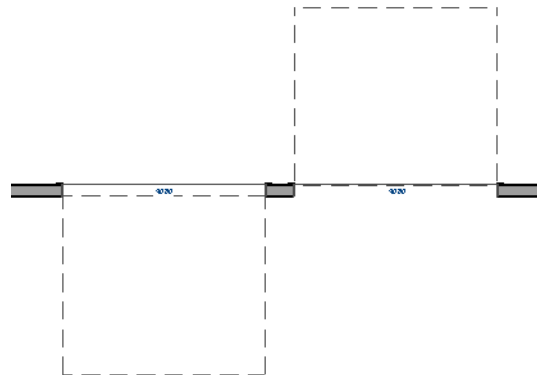

Unlike other door types, the Swing side of a garage door cannot be modified using the edit handles.

## IN DOOR SCHEDULES

Both Hinge Side and Swing can be included in Door Schedules. See [Columns to Include on page 689](#).

---

## Special Doors

A variety of special doors and doorways can be created in Chief Architect.

### TRANSOMS ABOVE DOORS

Transom windows above doors are created the same as other stacked windows. See [Grouped Windows on page 582](#).

### WRAPPED OPENINGS

Wrapped openings of various shapes are available in the **Doors & Doorways Library**.

You can also create a wrapped opening by unchecking **Use Interior Casing** and/or **Use Exterior Casing** in a Doorway's Door Specification dialog. See [Casing Panel on page 563](#). If base molding is present, it will wrap around the opening.

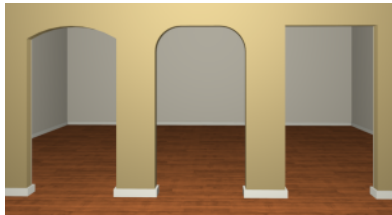

### RECESSED DOORS

A door placed in a brick or stone wall is often recessed into the wall's exterior. In the illustration below, the door to the right is recessed, so the brick wraps the opening. The door on the left is not recessed, so the casing is outside the brick.

You can specify a door as recessed in the Door Specification dialog. See [Options Panel on page 561](#).

### BLOCKED DOORS AND WINDOWS

Combinations of doors and windows can be blocked. Blocked units are mulled together and can be copied together as a unit. Blocked units containing doors can be treated as either windows or doors for materials list and schedule generation. See [Mulled Units on page 583](#).

### OPENINGS IN RAILINGS

Use the **Doorway**  tool to open a railing for a stairway or other access.



To open a railing across an entire section, resize the doorway's **Width** so that it is greater than the length of the railing in the Door Specification dialog. The opening resizes to the maximum width possible for that space. See [General Panel on page 559](#).



To add a gate, specify the doorway's **Door Type** as a Door, then choose an appropriate gate as the **Door Style**. A selection of gates is available in the Fences & Railings library folder. See [Placing Library Objects on page 972](#).

### CREATING A DOORWAY WITH A RAILING

When a railing is specified as **No Room Def**, it can be positioned within a **Doorway** .



#### *To create a doorway with railing*

1. Place a **Doorway**  at the desired location in your plan.
2. Select **Build> Railing and Deck> Straight Railing** , then click and drag to draw a railing parallel to the wall with the doorway.
3. Select the railing, then use the Resize edit handles to adjust the length of the railing as needed. See [Using the Edit Handles on page 216](#).
4. With the railing selected, click the **Open Object**  edit button.
5. On the GENERAL panel of the Railing Specification dialog, check **No Room Def** and click OK. See [General Panel on page 392](#).
6. With the railing still selected, Ctrl + drag it into position within the doorway. See [To move an object freely on page 244](#).

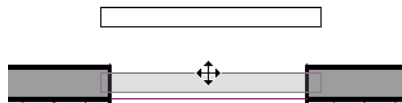

## PLACING A GABLE OVER A DOOR



Click the **Gable Over Door/Window** edit button to produce a gable roof over the selected door(s) the next time automatic roofs are built. See [Gable/Roof Lines on page 830](#).

You can manually edit or delete this gable line at any time. Your changes take effect when the automatic roofs are rebuilt. This can also be used with group selected doors.



## CUSTOM MUNTINS

Like windows, doors that are specified as “Glass” can have custom muntins. Custom muntins are created from CAD lines. See [Custom Muntins on page 590](#).

---

# Door Specification Dialog



To open the Interior or Exterior Door Specification dialog, select a door or group of doors and click the **Open Object** edit button or double-click on a door using the **Select Objects**  or any **Door**  tool.

Whether a selected door is Interior or Exterior depends on where it is placed. See [Interior vs Exterior Doors on page 544](#).

You can also open the specification dialog for the door(s) associated with a schedule row. See [Open Row Object\(s\) on page 686](#).



The Lintel, Framing, and Energy Values panels are also found in the Window Specification dialog. In addition, the Frame panel for windows is similar to the Jamb panel for doors. See [Window Specification Dialog on page 591](#).

The Door Specification dialog has the following panels:

## GENERAL PANEL

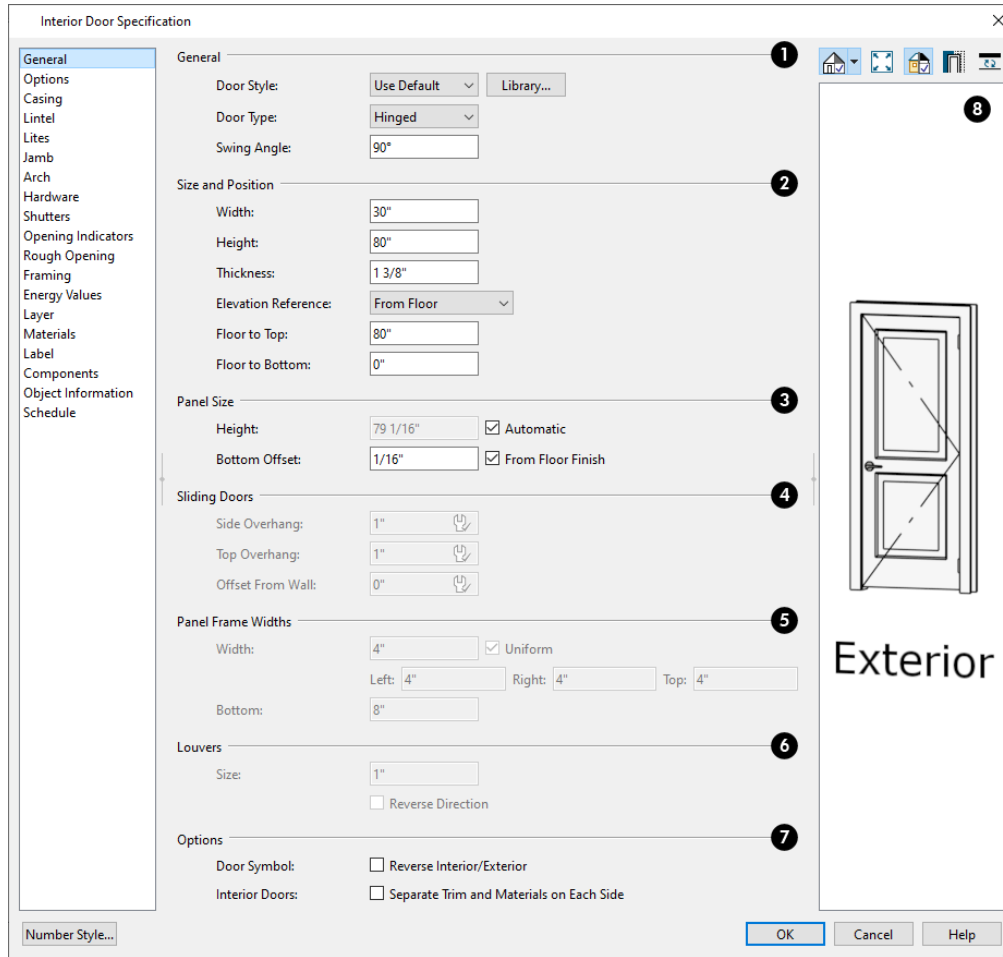

### 1 General

- **Door Style** - Select Slab, Glass Slab, Panel, Glass Panel, Louvered, or Glass Louver from the drop-down list; select a style from the Library; or choose “Use Default” to use the default door style set in the Door Defaults dialog. See [Door Defaults on page 544](#).
- Select “Library” from the drop-down list or click the **Library** button to choose a door symbol from the library. Once a library door is selected, its name is added to the Door Style list. See [Select Library Object Dialog on page 974](#).
- Specify the **Door Type** as Doorway, Hinged, Sliding, Pocket, Bifold, Garage, Fixed, Barn, or Shower. In the Door Defaults dialogs, the Door Type cannot be changed.
- Specify the **Swing Angle** of the selected door in plan view, between 0° and 180°. An angle of 0° displays the door as closed and an angle of 180° displays it as wide open. The Swing Angle for Bifold doors and double doors that swing from the center can be no more than 90°.

The Swing Angle also affects the door’s appearance in 3D views if **Draw Closed** is unchecked on the OPTIONS panel. See [Options Panel on page 561](#).

### 2 Size and Position

Specify the **Size and Position** of the selected door.

- Specify the **Width**, **Height**, and **Thickness** of the door. These values do not include the jamb unless Door Size Includes Jamb is selected on the JAMB panel.
- Select the **Elevation Reference** from the drop-down list. This determines where the next two settings are measured from and also affects their labels.
- Specify the height **to Top**, measured from the selected Elevation Reference to the top of the door frame.
- Specify the height **to Bottom**, measured from the selected Elevation Reference to the bottom of the door frame.

### 3 Panel Size

- When **Automatic** is checked, the door panel's **Height** is the door height specified above minus the Bottom Offset and will update if changes are made to either of these values or the Elevation Reference. Uncheck this box and specify a panel **Height** that will not be affected if those settings change.
- Specify the **Bottom Offset**, which is the gap between the bottom of the door panel and the floor.
- When **From Floor Finish** is checked, the Bottom Offset is measured from the surface of the floor finish. Uncheck this box to instead measure the offset from the top of the subfloor.

### 4 Sliding Doors

The **Sliding Doors** settings are available for Slider, Pocket, and Barn Doors.

- Specify the **Side** and **Top Overhang** values, which control how much the selected door extends past its wall opening. Only available for Barn Doors.
- Specify the **Offset from Wall**, which is how far the selected door is offset from its default location. Slider and Pocket Doors are centered in the wall's Main Layer by default, while Barn Doors are positioned against the wall surface.

### 5 Panel Frame Widths

Specify the dimensions of the selected door's rails and stiles. Only available for Glass, Panel, and Louvered doors.

- Specify the **Width** of the stiles and top rail. Uncheck **Uniform** to specify separate values for the **Left**, **Right**, and **Top** of the frame, or leave it checked to use the same value for all three.
- Specify the height of the **Bottom** rail.

### 6 Louvers

- Specify the **Size**, or vertical height, of the selected door's louvers. Only available for Louvered and Glass Louvered doors.
- By default, louvers face the direction that the door swings. Check **Reverse Direction** to reverse the direction that they face.

### 7 Options

- Check **Reverse Interior/Exterior** to reverse the two sides of the selected door so that they face the opposite direction. Only available when a door symbol from the Library is specified as the Door Style. See [Door Sides on page 552](#).



- Check **Separate Trim and Materials for Each Side** to specify the casing, lintels, and all materials for each side of the selected interior door independently. When unchecked, the two sides of the door use the same trim and materials. Only available when the selected door is placed in an interior wall. See *Exterior and Interior Walls on page 351*.

## 8 Preview

A preview of the door displays on the right side of the dialog box. A label indicates which side of the door is its Interior and which is its Exterior. See *Dialog Preview Panes on page 22*.

## OPTIONS PANEL

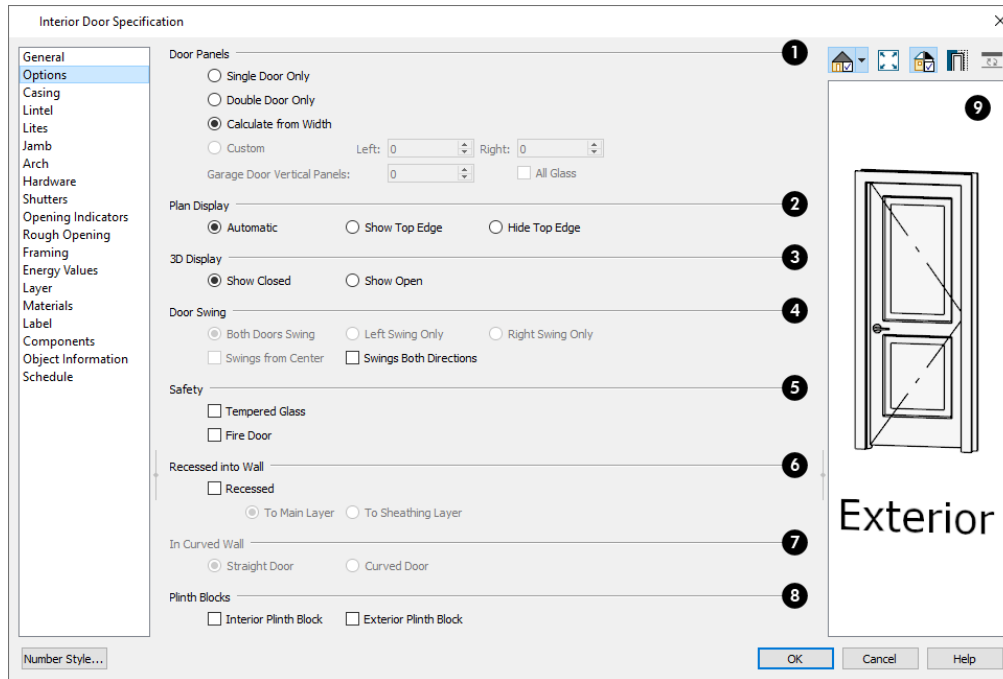

## 1 Door Panels

Specify the number of **Door Panels** or sections that the selected door has. See *Door Style and Panels on page 552*.

- Select **Single Door Only** to force the selected hinged, pocket or bifold door to be a single door, regardless of its width.
- Select **Double Door Only** to force the selected hinged, pocket or bifold door to be a double door, regardless of its width.
- Select **Calculate From Width** to use the program defaults. Hinged and pocket doors default to **Single Door** when less than four feet (1200 mm) wide; bifold doors do so when less than three feet (900 mm) wide. If the width is greater than this, **Double Door** is the default.

Note: The Calculate From Width defaults are not editable.

- Select **Custom**, then specify the number of panels on the **Left** and/or **Right** door components. Only available for sliding, pocket, and bifold doors.
- For a selected Garage Door, specify the number of **Vertical Panels**.

- When **All Glass** is unchecked, only the third panel from the bottom the door is a glass panel: the rest are solid panels. Check this box to make all of the panels glass. The number and style of the lites and the Muntin Width can be specified on the LITES panel.

## 2 Plan Display

The **Plan Display** settings control the display of dashed wall surface lines above the door in plan view. See *In Plan Views on page 548*.

- Select **Automatic** to display wall surface lines only when the selected door is a Doorway.
- Select **Show Top Edge** to display wall surface lines regardless of the door type.
- Select **Hide Top Edge** to not show wall surface lines regardless of door type.

## 3 3D Display

Specify whether the selected door is shown open or closed in 3D and cross section/elevation views.

- If **Show Open** is selected, the Swing Angle set on the *General Panel on page 559* is used.

## 4 Door Swing

Specify how the selected door swings. Most options here are only available when the selected Hinged or Pocket door is a Double Door. Not available for Bifold, Slider or Garage doors. See *Changing Door Swings on page 553*.

- Check **Both Doors Swing** to allow both sides of a Double Door to swing.
- Check **Left Swing Only** or **Right Swing Only** to allow only the left or right side of a Double Door to swing.
- Check **Swings from Center** to create a Double Door with hinges at the center rather than at the outside edges.
- Check **Swings Both Directions** to allow a door or both sides of a Double Door to swing both directions.

## 5 Safety

The **Safety** settings affect how the selected door is listed in the Door Schedule. See *Schedules and Object Labels on page 681*.

- Check **Tempered Glass** to specify the selected door as having tempered glass.
- Check **Fire Door** to specify the selected door as being a fire door.

## 6 Recessed Into Wall

The **Recessed into Wall** options allow you to recess the selected door's jamb into a wall, away from the exterior surface. This setting also affects the exterior casing and lintel, if used. Only available if the door is placed in a multi-layered wall. See *Wall Type Definitions on page 384*.

- Check **Recessed** to activate the settings that follow.

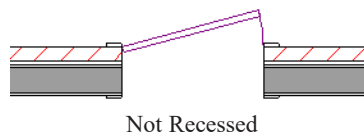

- Select **To Main Layer** to recess the door to the wall's Main Layer.



Recessed to Main Layer

- Select **To Sheathing Layer** to recess the door to the wall's sheathing layer.



Recessed to Sheathing Layer

## 7 In Curved Wall

Specify whether a door placed in a curved wall is **Straight** or **Curved**. This setting affects both the frame and the door panel. Slider, Pocket, and Barn Doors are specified as Curved automatically and cannot be changed. See [Drawing Curved Walls on page 360](#).

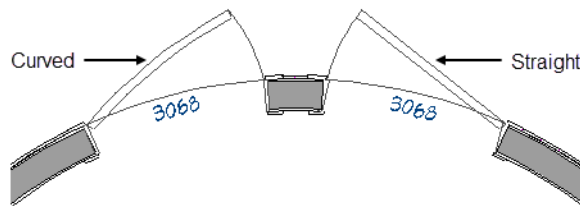

## 8 Plinth Blocks

Add an **Interior Plinth Block** and/or **Exterior Plinth Block** to the selected door. Plinth blocks do not display in 3D views, but are counted in the Materials List.

## 9 Preview

A preview of the door displays on the right side of the dialog box. See [Dialog Preview Panes on page 22](#).

## CASING PANEL

The CASING panel is also found in the Window and Muller Unit Specification dialogs. See [Window Specification Dialog on page 591](#).

By default, interior and exterior casing is suppressed for doorways placed into railings: including solid railings and railing pony walls.

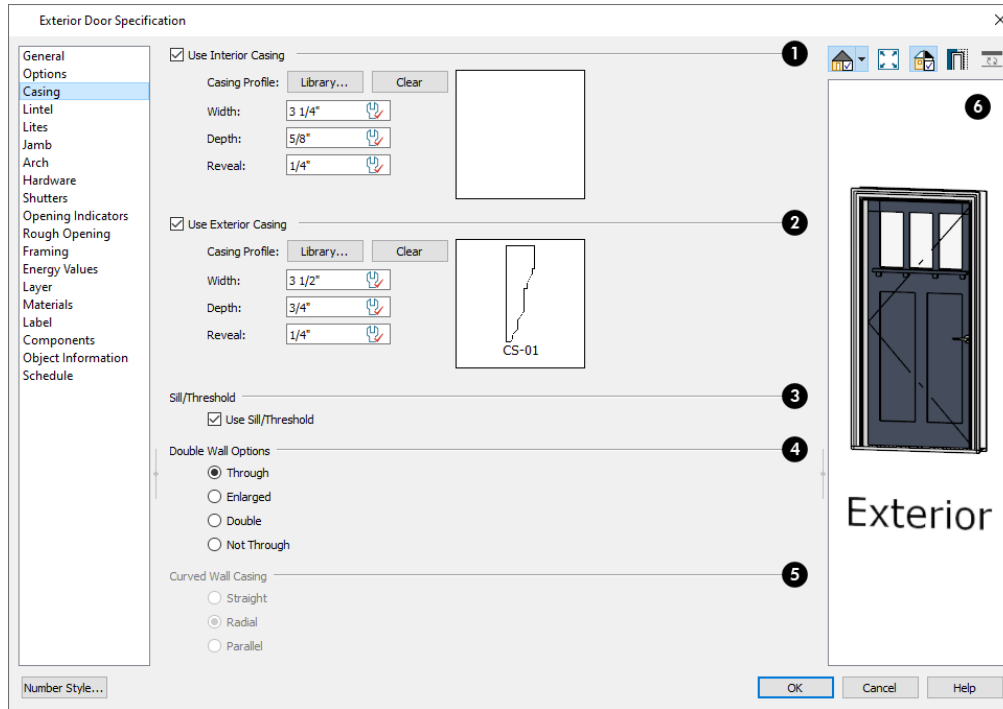

## 1 Use Interior Casing

When this box is unchecked, no casing is used and the settings that follow are disabled.

- **Casing Profile** - Click the **Library** button to select a molding profile for the casing. A preview of the casing profile displays to the right. See [Select Library Object Dialog on page 974](#).
- Click the **Clear** button to remove a selected casing profile from the door. When no profile from the library is selected, a basic rectangular stock profile is used.
- Specify the **Width** of the selected casing.
- Define the **Depth** of the selected casing, as measured from the back to the front of the casing profile.
- Define the **Reveal**, which is the distance between the inside edge of the door or window frame and the inside edge of the casing.

## 2 Use Exterior Casing

Check this box to enable the settings that follow, then specify the exterior casing for the selected door(s) These settings are the same as those for the Interior Casing, and are not available for doors in interior walls unless **Separate Trim and Materials on Each Side** is checked on the GENERAL panel. See [General Panel on page 559](#).

## 3 Sill/Threshold

Uncheck this box to prevent a sill from being generated under the door. Not available for windows. See [Displaying Doors on page 548](#).

## 4 Double Wall Options

These options affect doors and windows placed in a Double Wall. See [Double Walls on page 382](#).

- Select **Through** to create a single jamb running through both Double Walls. This option is selected by default.
- If **Enlarged** is selected, casing is created only on the wall the door is inserted in. The opening on the other wall is enlarged to accommodate the casing.
- Select **Double** to place a second door in the Double Wall opposite the selected door. This second door cannot be selected. Casing is produced as with the **Through** type window.
- Select **Not Through** to place the door in one wall with no corresponding opening in the other wall.

## 5 Curved Wall Casing

These settings are enabled if the selected door or window is located in a curved wall. See *Drawing Curved Walls on page 360*.

- Door and window casing and jamb can be constructed three ways in curved walls:
- **Straight** - Both the door and casing are straight. This can be used where the wall's curvature is not too sharp and the opening is not too wide. Not available for Sliding, Pocket, or Barn Doors.

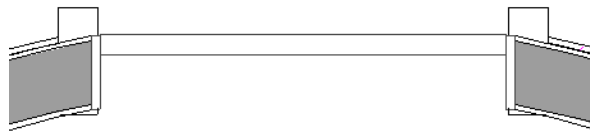

- **Radial** - A vertical surface that would be perpendicular to a straight wall has its plane pass through the wall's center of curvature.



- **Parallel** - A vertical surface that would be perpendicular to a straight wall remains parallel to the line from the wall center through the opening center.



## 6 Preview

A preview of the door displays on the right side of the dialog box. If casing is not specified for a Doorway or Passthrough, the **Show Wall** option will be toggled on automatically. See *Dialog Preview Panes on page 22*.

### LINTEL PANEL

The settings on the LINTEL panel allow you to assign a lintel: a top molding that meets the side casing using a butt joint instead of a mitered joint.

The LINTEL panel is also found in the Window and Muller Unit Specification dialogs. See *Window Specification Dialog on page 591*.

The profiles and materials of door and window lintels can be included in Room Finish Schedules. See *The Schedule Tools on page 682*.

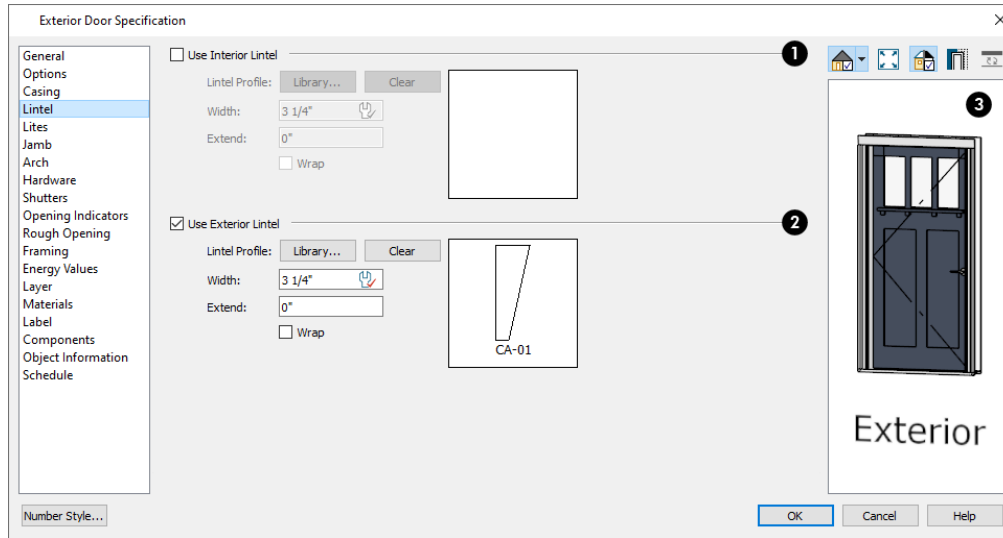

### 1 Use Interior Lintel

Check **Use Interior Lintel** to enable the settings that follow, then specify the lintel applied to the interior side of the selected door(s) using these settings. When this box is unchecked, no lintel is used.

- **Lintel Profile** - Click the **Library** button to select a molding profile for the lintel. A preview of the selected profile displays to the right. See [Select Library Object Dialog on page 974](#).
- Click the **Clear** button to remove a selected lintel profile from the door.
- Specify the **Width** of the lintel. This value is independent of the casing's width; however, the lintel does inherit its depth from the casing.
- Specify how far to **Extend** the lintel past the outside edges of the casing on each side.
- Check **Wrap** to wrap the lintel profile back toward the wall.

### 2 Use Exterior Lintel

Check **Use Exterior Lintel** to enable the settings that follow, then specify the exterior lintel for the selected door(s) using these settings. These settings are the same as those for the Interior Lintel, and are not available for doors in interior walls unless Use Exterior Trim and Materials is checked on the GENERAL panel. See [General Panel on page 559](#).

### 3 Preview

A preview of the door displays on the right side of the dialog box. See [Dialog Preview Panes on page 22](#).

## LITES PANEL

The settings on the LITES panel of the Door Specification dialogs are only available when the selected door is specified as a Glass door on the [General Panel on page 559](#). These settings are also found on the LITES panel of the Window Specification dialog. See [Lites Panel on page 599](#).

## JAMB PANEL

The settings on the JAMB panel are similar to those on the FRAME panel of the Window Specification dialog. See [Frame Panel on page 598](#).

By default, Has Jamb is unchecked for doorways placed into railings: including solid railings and railing pony walls.

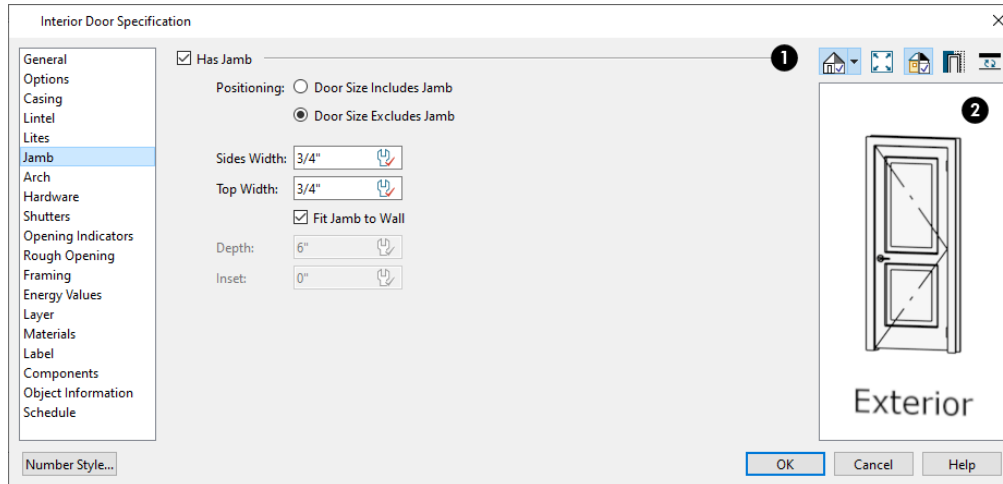

## 1 Has Jamb

Check **Has Jamb** to enable the settings that follow, then specify the attributes of the selected door's jamb using those settings. The jamb is not included in the door's size, which is set on the [General Panel on page 559](#).

- Specify the **Positioning** of the door. These settings affect what the door's Size settings on the GENERAL panel are describing; however, switching these settings does not affect the Size values:
  - Select **Door Size Includes Jamb** to specify size as a total of the door panel plus jamb width.
  - Select **Door Size Excludes Jamb** to specify the size of the door panel only.
- These values only affect the door's specified size when Door Size Includes Jamb is selected, above:
- Specify the **Sides Width**, which is the thickness of the pieces of the door jamb that display in plan view. This value is subtracted from the "pocket" side rough opening for Pocket Doors when wall framing is generated. See [Pocket Doors on page 546](#).
- Specify the **Top Width**, which is the thickness of the top vertical piece of the door jamb.
- Uncheck **Fit Jamb to Wall** to specify the Depth and Inset of the selected door's jamb. When this box is checked, the jamb Depth automatically extends from the Recessed Into Wall layer to the wall's inside surface with an Inset of 0". The Recessed Into Wall layer is specified on the OPTIONS panel of this dialog.
- Specify the **Depth** of the door jamb from front to back.
- Specify the jamb's **Inset**, which is measured from the Recessed Into Wall layer and moves the door jamb towards its interior side. If used, the casing and lintel are not affected by this setting.

## 2 Preview

A preview of the door displays on the right side of the dialog box. See [Dialog Preview Panes on page 22](#).

## ARCH PANEL

The settings on the ARCH panel are also found in the Window Specification dialog; however, it is not available for window symbols, and its settings are not available if a selected window has been modified using the SHAPE panel. See [Shape Panel on page 601](#).

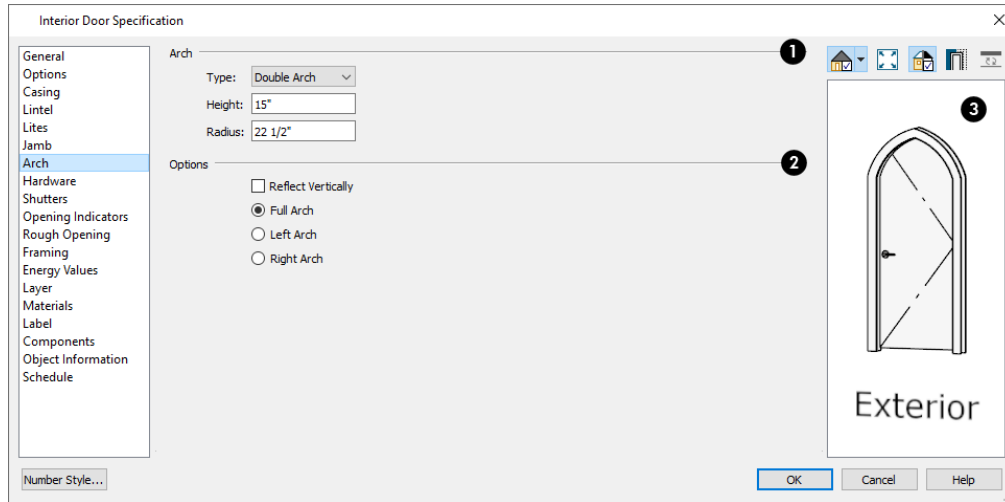

## 1 Arch

Define the style and size of the **Arch**.

- Select a **Type** of arch from the drop-down list.
- Specify the **Height** of the arch, as measured from the base of the arch to the top of the door. Not available for Round Top and Octagonal Arches.
- The **Radius** can also be defined for Tudor and Double Arches.

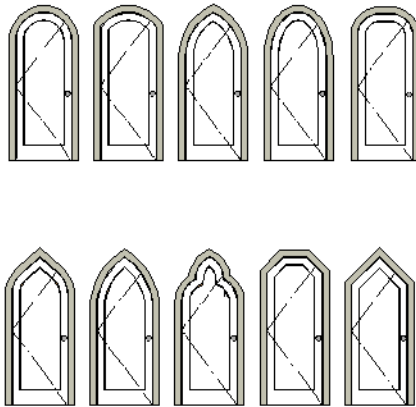

## 2 Options

Define the orientation of the arch.

- Check **Reflect Vertically** to reflect the arch, top to bottom. This option cannot be used if a Sill is specified, and is typically used with windows rather than doors. See [Sill Panel on page 596](#).
- Select **Full Arch** to produce an arch with the apex at the door's center.
- Select **Left Arch** to produce an arch with the apex on the door's right side.
- Select **Right Arch** to produce an arch with the apex on the door's left side.



Note: The Left and Right settings here on this panel refer to the door or window as viewed from its exterior.

### 3 Preview

A preview of the door displays on the right side of the dialog box. See *Dialog Preview Panes on page 22*.

## HARDWARE PANEL

Many of the settings on the HARDWARE panel are Dynamic Defaults: if “Use Default” is selected, the setting in the Door Defaults dialog for the selected door’s Type is used. See *Dynamic Defaults on page 79*.

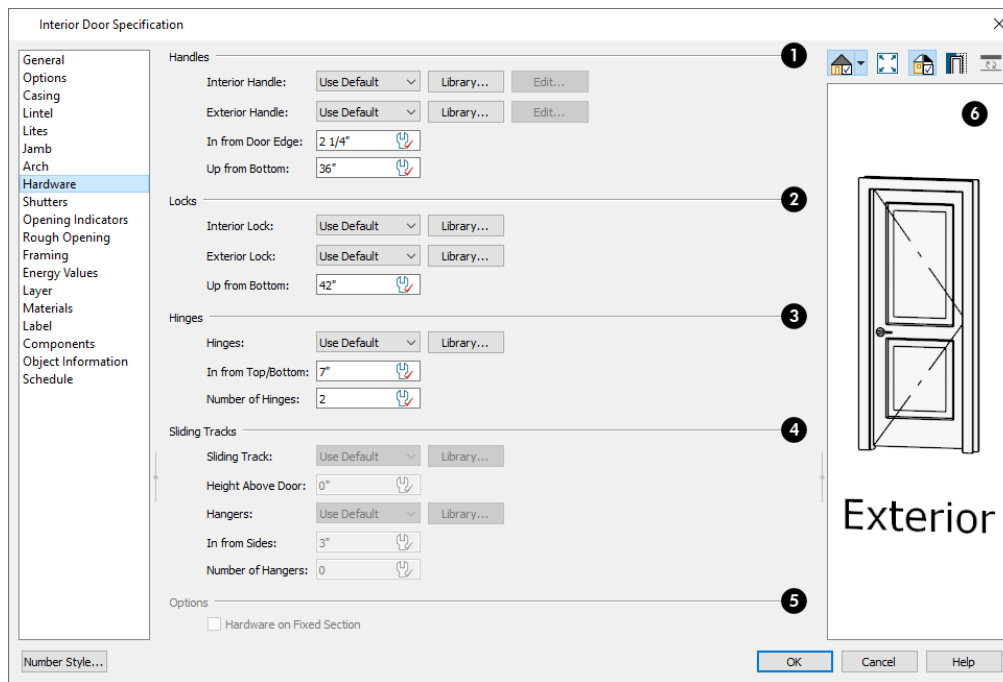

### 1 Handles

- Select an **Interior Handle** and/or **Exterior Handle** from the drop-down lists. Select “Library” or click the **Library** button to select a handle from the library. See *Select Library Object Dialog on page 974*.
- When a handle from the Library is selected, you can click the **Edit** button to customize its size and angle. See *Hardware Size/Orientation Dialog on page 659*.
- Specify the location of the door handles **In From Door Edge**.
- Specify the location of the door handles **Up From Bottom**.

### 2 Locks

- Select an **Interior Lock** and/or **Exterior Lock** from the drop-down lists. Select “Library” or click the **Library** button to select a lock from the library.

- When a lock from the Library is selected, you can click the **Edit** button to customize its size and angle. See [Hardware Size/Orientation Dialog on page 659](#).
- Specify the location of the door locks **Up From Bottom**. The locks use the same In From Door Edge value as the handles.

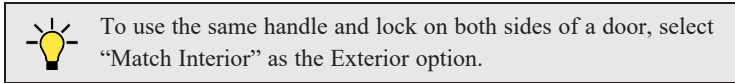

### 3 Hinges

Only Hinged and Bifold doors receive hinges.

- Select a style of **Hinges** from the drop-down list. Select “Library” or click the **Library** button to select a hinge style from the library.
- Specify the distance **In From Top/Bottom** of the door to the center of the top and bottom hinges.

Note: For hinges to look right, it is best to have at least a 1/4" (6 mm) reveal for the interior, or hinge side, door casing.

- Specify the **Number of Hinges** on the selected door. Interior hinged doors and bifold doors typically have two hinges while exterior hinged doors have three.

### 4 Sliding Tracks

Only available when a Barn Door is selected.

- Select a **Sliding Track** from the drop-down list. Select “Library” or click the **Library** button to select a track from the library. See [Select Library Object Dialog on page 974](#).
- Specify the track’s **Height Above Door**.
- Select a style of **Hangers** from the drop-down list. Select “Library” or click the **Library** button to select a hanger from the library.
- Specify the distance **In From Sides** of the door to the center of the outermost hangers.
- Specify the number of **Hangers** to be evenly spaced along the door.

### 5 Options

Check **Hardware on Fixed Section** to include handles, locks, and hinges on the fixed side of a double Hinged door. Only available for Double Doors with Left or Right Swing Only selected. See [Options Panel on page 561](#).

### 6 Preview

A preview of the door displays on the right side of the dialog box. See [Dialog Preview Panes on page 22](#).

## SHUTTERS PANEL

The settings on the SHUTTERS panel of the Door Specification dialogs are also found on the Shutters panel of the Window Specification dialog. See [Shutters Panel on page 570](#).

## OPENING INDICATORS PANEL

The settings on the OPENING INDICATORS panel control the appearance of the selected hinged or sliding door's opening indicator in camera views using the Vector View Rendering Technique. These settings are also available for windows and

cabinets. See [Opening Indicators on page 549](#).

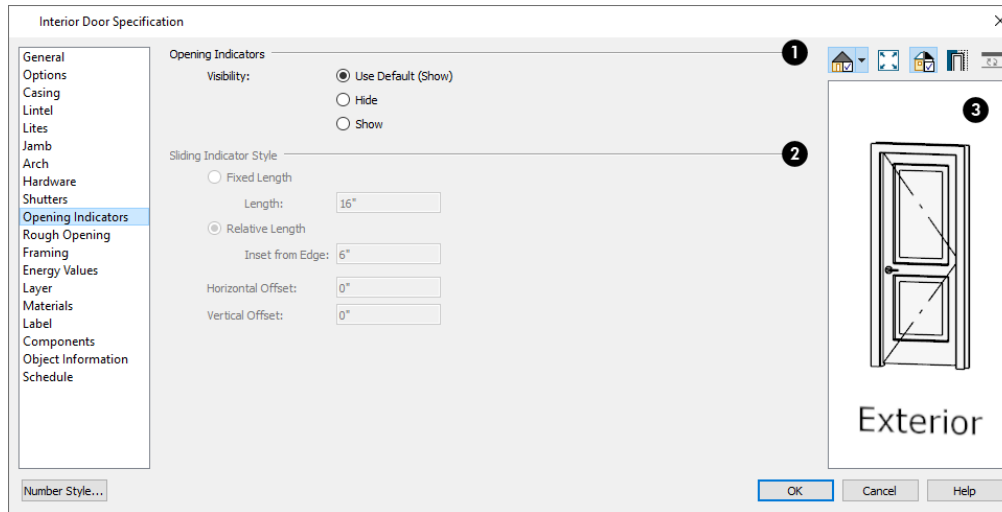

### 1 Opening Indicators

Specify whether the selected door's opening indicators display.

### 2 Sliding Indicator Style

Available for Sliding, Pocket, Barn, and Garage doors, as well as Single Hung, Double Hung, and Sliding windows. Sliding indicator arrows display centered over all movable door panel(s) or window component(s).

- Select **Fixed Length**, then specify the desired **Length** of the indicator arrow in the text field.
- Select **Relative Length** for an indicator arrow sized relative to the movable component it is drawn over.
- Specify the **Inset from Edge**, which is the distance of each end of the indicator arrow line from the adjacent edge of the associated door panel or window component. If a panel or component is not wide or tall enough to accommodate the Inset distance on both ends of the arrow line, this value will be ignored and an arrow 10" (250 mm) long will be used.
- Specify the **Horizontal Offset**, which allows you to offset the arrow line to the right or left using a positive or negative value.
- Specify the **Vertical Offset**, which allows you to offset the arrow line upwards or downwards using a positive or negative value.

### 3 Preview

A preview of the door displays on the right side of the dialog box. Opening indicators only display in Vector Views. See [Dialog Preview Panes on page 22](#).

## ROUGH OPENING PANEL

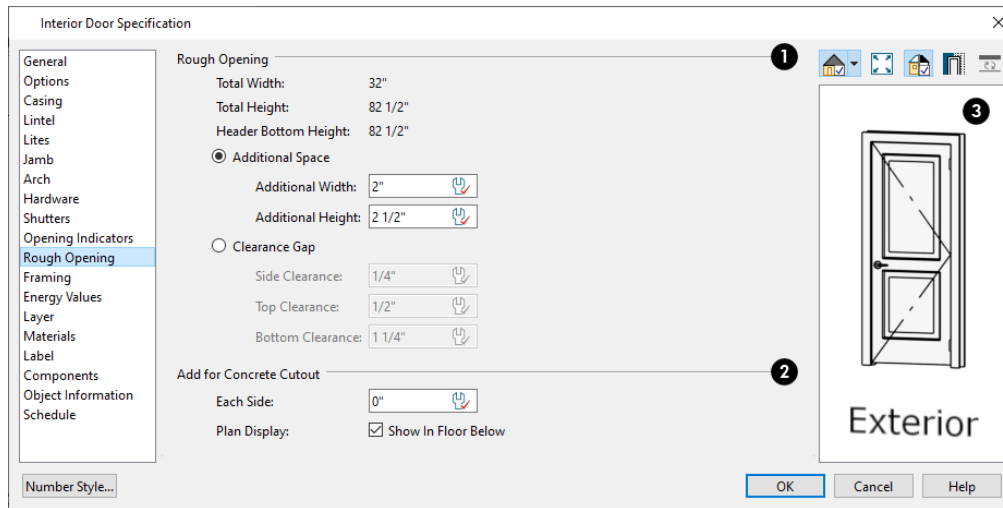

### 1 Rough Opening

- The **Total Width**, **Total Height** and the **Header Bottom Height** are reported here for reference.
- Specify the **Behavior** used to define the rough opening:
  - When **Additional Space** is selected, the rough opening is equal to the specified size of the door or window plus additional space, specified below.
  - When **Clearance Gap** is selected, the rough opening for doors is equal to the specified size of the door plus the thickness of its jamb plus the values specified below. For windows, the rough opening is equal to the specified size plus the values set below.
    - When **Additional Space** is the selected Behavior:
      - Specify the total **Additional Width** added to the width of the window frame or that of the door, not including jamb.
      - Specify the total **Additional Height** added to the height of the window frame or that of the door, not including jamb. If the selected opening at floor level, the bottom of the rough opening will be at the height of the subfloor.
    - When **Clearance Gap** is the selected Behavior:
      - Specify the **Side Clearance**, which is the space on each side of the window frame or door jamb, between it and the adjacent trimmers.
      - Specify the **Top Clearance**, which is the space above the window frame or door jamb, between it and the header or wall top plate.
      - Specify the **Bottom Clearance**, which is the space below the window frame or door jamb, between it and the sill, bottom plate, or subfloor.

### 2 Add for Concrete Cutout

- Specify the amount to add to **Each Side** of the door opening when the upper part of the door is in a framed wall and the lower part is located in a concrete or masonry wall, stem wall, or garage curb. See *Wall Type Definitions on page 384*.

- Uncheck **Show in Plan** to suppress the display of the concrete cutout in plan views. A concrete cutout will only display in plan views if it is located in a garage curb. See *In Plan Views on page 548*.

## FRAMING PANEL

The settings on the FRAMING panel control how the selected door or doors is framed. A similar panel is also found in the Window Specification dialog. See *Window Specification Dialog on page 591*.

 Chief Architect is dependent upon user input and does not calculate loads or perform structural analysis. Always consult your local building authorities and contact a licensed engineer for structural calculations.

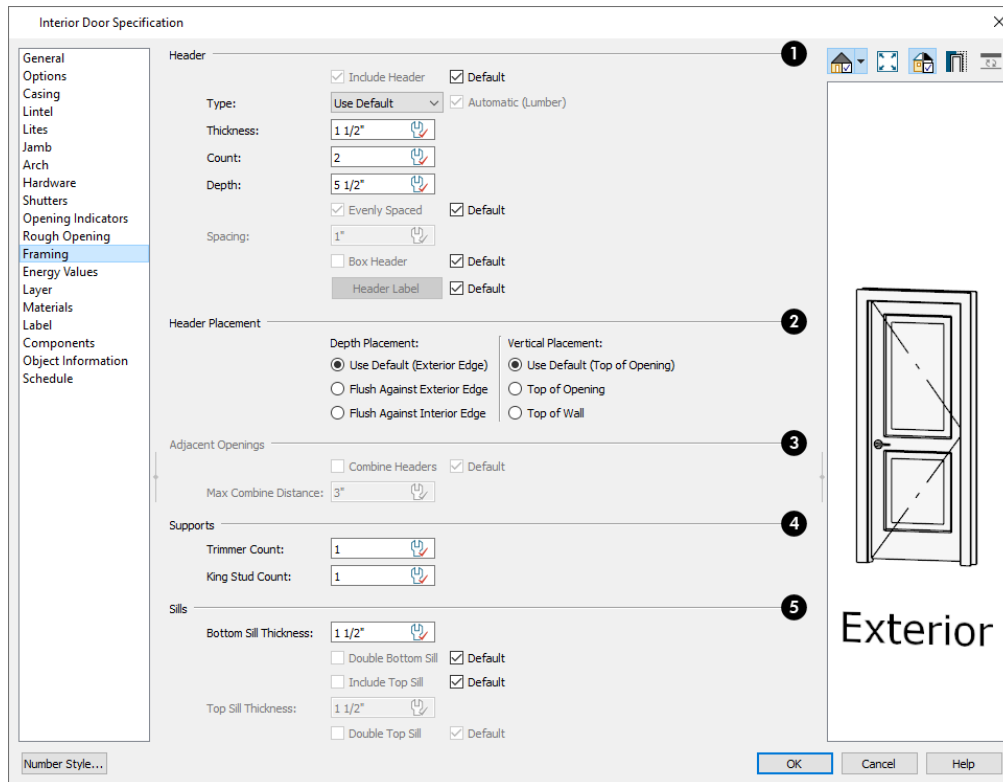

### 1 Header

Specify the characteristics of the selected door's header. See *Headers on page 852*.

- Uncheck **Include Header** to prevent a structural header from generating when wall framing is created. When this box is checked, a header as defined below is generated; when it is unchecked, a single, non-structural, horizontal framing member of the same type as the wall studs is created above the door opening.
- Select the header's framing member **Type** from the drop-down list. See *Structure Types on page 886*.
- When **Automatic** is checked, the program will confirm that the Type selected above agrees with the framing material used by the wall, and will generate a different header Type if it does not. The Type that will be generated is reported in parentheses for reference. When unchecked, the specified Type is used regardless of the wall's structural material.
- Specify the **Thickness** of each header framing member.

- Specify the **Count**, which is the number of the framing members used to create the header. Up to 10 header boards can be specified, but only those that fit within the wall's framing layer will be generated when wall framing is created.
- Specify the vertical **Depth** of the header. This value does not include the top and bottom chords of a Box Header.
- In the Door and Window Defaults dialogs, an additional **Calculate from Width** check box is available. When checked, the header Depth is automatically calculated based on settings in the Framing Defaults dialog and the door's current width. See *Openings Panel on page 865*.
- When **Evenly Spaced** is checked, the boards that comprise the header are evenly spaced within the wall's framing layer. Uncheck this box to specify the spacing of the header boards, below.
- When Evenly Spaced is unchecked, specify the **Spacing** of the vertical boards that comprise the header.
- Check **Box Header** to add horizontal top and bottom rails above and below the vertical rails. These horizontal boards are not included in the header Depth. See *Headers on page 852*.
- Specify the attributes of the **Header Label** for the selected door's headers. See *Framing Labels on page 879*.

## 2 Header Placement

Specify where the selected door's header is positioned within the wall assembly. The defaults for these values are set in the Door Defaults dialogs. See *Headers on page 852*.

- **Depth Placement** - A header that does not span the full thickness of the wall's framing layer can be **Flush Against Exterior Edge** of that layer, or **Flush Against Interior Edge**.
- **Vertical Placement** - A header may be positioned directly above the **Top of Opening**, just above the Rough Opening, or at the **Top of Wall**, just below the wall's bottom top plate.

## 3 Adjacent Openings

These options are only available when Top of Wall is selected for the Vertical Header Placement, above.

- Check **Combine Headers** to have any doors and/or windows close to the selected opening share the same header. In addition to being closely positioned, the other openings must have the same header Depth and have Top of Wall selected. Not all openings must have this box checked, however.
- Specify the **Maximum Combine Distance**, which is the largest distance between openings that will allow them to share a header.

## 4 Supports

Specify the number of **Trimmers** and **King Studs** to be generated on each side of the selected door.

## 5 Sills

When the bottom of a door is raised sufficiently off the floor, it will require a sill as part of its framing.

- Specify the **Bottom Sill Thickness**, which is the vertical thickness of the sill board.
- Check **Double Bottom Sill** to generate two bottom sill members of the specified thickness instead of one.
- Check **Include Top Sill** to include a sill board across the top of the Rough Opening. If Top of Opening is selected as the header's Vertical Placement, the header will be positioned on top of the sill.
- Specify the **Top Sill Thickness**.
- Check **Double Top Sill** to generate two top sill members of the specified thickness instead of one.

### **ENERGY VALUES PANEL**

The settings on the ENERGY VALUES panel are also found on the panel of the same name in the Window Specification dialog. See *Energy Values Panel on page 606*.

### **LAYER PANEL**

The LAYER panel is available for a variety of different objects. For more information, see *Layer Panel on page 186*.

### **MATERIALS PANEL**

The MATERIALS panel is available for a variety of objects throughout the program. For more information, see *Materials Panel on page 1055*.

### **LABEL PANEL**

Door labels display in plan view and cross section/elevation views when the “Doors, Labels” is turned on and use the Text Style assigned to that layer. See *Door Labels on page 550*.

For information about the settings on this panel, see *Label Panel on page 700*.

### **COMPONENTS PANEL**

The information on the COMPONENTS panel can be used in the materials list. For more information, see *Components Panel on page 1330*.

### **OBJECT INFORMATION PANEL**

The information entered on the OBJECT INFORMATION panel can be used in schedules and the materials list. For more information, see *Object Information Panel on page 1331*.

### **SCHEDULE PANEL**

The settings on the SCHEDULE panel determine which schedule categories the selected door is included in. See *Schedule Panel on page 704*.

### **MANUFACTURER PANEL**

The MANUFACTURER panel provides contact information for the selected door’s manufacturer. Only available for doors from Manufacturer library catalogs. See *Manufacturer Catalogs on page 961*.

# Windows

## Chapter 16

Chief Architect can model a wide variety of windows. Fixed glass, hung, casement, sliding, awning, hopper, and louver window styles can all be created with the standard Window tool. The shape of a window can be angled or made into a round top or other arch styles. Chief Architect can create bay, box, and bow windows with a single click. In addition, the library contains many muller window combinations and additional name-brand door catalogs are also available for download from our website, [chiefarchitect.com](http://chiefarchitect.com).

Once windows have been placed in the model, the program can automatically generate a window schedule. See *The Schedule Tools* on page 682.

### TOPICS

<b>Window Defaults</b> .....	<b>577</b>
<b>Window Tools</b> .....	<b>577</b>
<b>Special Windows</b> .....	<b>579</b>
<b>Grouped Windows</b> .....	<b>582</b>
<b>Mulled Units</b> .....	<b>583</b>
<b>Window Levels</b> .....	<b>585</b>
<b>Displaying Windows</b> .....	<b>586</b>
<b>Editing Windows</b> .....	<b>588</b>
<b>Custom Muntins</b> .....	<b>590</b>
<b>Window Specification Dialog</b> .....	<b>591</b>
<b>Bay, Box, and Bow Windows</b> .....	<b>608</b>
<b>Bay, Box, Bow Windows and Roofs</b> .....	<b>610</b>
<b>Bay/Box and Bow Window Specification Dialogs</b> .....	<b>613</b>



---

## Window Defaults



Default Settings can be accessed by selecting **Edit> Default Settings**. Select Window from the Default Settings dialog and click the **Edit** button.

You can also double-click the **Window Tools**  parent button to open the Window Defaults dialog.

The settings in the Window Defaults dialog control the attributes of a window when it is initially placed in a plan, so you should define the type of window that will be placed most often in your model. See [Default Settings on page 77](#).

The panels in the Window Defaults dialog are similar to those found in the Window Specification dialog, with one exception:

On the GENERAL panel of the Window Defaults dialog, you can specify the **Minimum Separation** between window and/or door units in the plan.

Minimum Separation:

The **Minimum Separation** value in the Window Defaults dialog specifies how close window and/or door units can be to each other. This setting also determines the width of the shared casing between windows.

For more information, see [Window Specification Dialog on page 591](#).

### DYNAMIC WINDOW DEFAULTS

A variety of window default values are dynamic, including the Window Type, Casing, Lintel, Sash, Frame, Treatments, Framing, and Rough Opening. All Materials are also dynamic. When a dynamic default is changed, existing windows using the default value are affected. See [Dynamic Defaults on page 79](#).

### WINDOW FRAMING

The defaults for window framing can be defined in the Window Defaults dialogs. You can also specify an additional amount to cutout for window openings in concrete walls when the upper part of the window is located in a framed wall. See [Rough Opening Panel on page 606](#) and [Framing Panel on page 606](#).

The default header depths for different spans can be set in the Framing Defaults dialog. See [Openings Panel on page 865](#).

---

## Window Tools



To place a window, select **Build> Window** and choose the desired Window Tool. Move your mouse pointer over a wall section, then click to place a window in the wall at that location.

- If there is room enough along the wall to fit a 6" (150 mm) wide Standard Window, a preview of the window will display and a window can be placed.
- The Bay, Box, and Bow Window tools do not have preview outlines. If a minimum width of 30" (725 mm) cannot be accommodated at the location where you click, a warning message will display and a window unit will not be created.

Standard Windows, Passthroughs, and Wall Niches can be placed in both straight and curved walls, as well as span across straight, collinear wall segments. In contrast, a Bay, Box, or Bow Window can only be placed in a single, straight wall.

Windows can also be placed in the Pony Walls; however, if the upper wall is a Railing, only Windows, Passthroughs, and Wall Niches can be placed provided that they are located entirely within the lower wall. See [Pony Walls on page 354](#).

Windows cannot be placed in a wall specified as Invisible or if the wall in question is on a locked layer. See [Locking Layers on page 178](#).

## STANDARD WINDOWS

 Select **Build> Window> Window**, then click on a straight or curved wall to place a Standard Window at that location.

A Standard Window is a single window that is not a bay, box, bow window, a corner window or a blocked unit. These special types are made up of multiple Standard Windows.

A Standard Window that is part of a special window is called a Component Window.

Standard Windows can be specified as any of a variety of window types, such as double hung, casement and awning. See [Window Specification Dialog on page 591](#).

## BAY WINDOWS

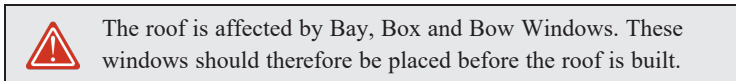

 A **Bay Window** is composed of three wall sections, each with a single component window. The two side walls are at an angle to the main wall. Select **Build> Window> Bay Window** and click on a straight wall to produce a bay window.

When initially placed, bay windows measure 2'-2" across at the front, 4'-2" across at the back, and are 1'-0" deep. The component windows are specified in the Window Defaults dialog and their sizes adjust to fit the available space.

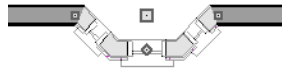

## BOX WINDOWS

 A **Box Window** is a bay window with side angles set at 90°. Select **Build> Window> Box Window** and click on a straight wall to produce a box window.

Box windows initially measure 4'-2" wide with a depth of 1'-6". The component windows are specified in the Window Defaults dialog and their sizes adjust to fit the available space.

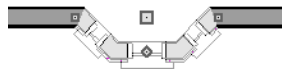

## BOW WINDOWS

 A **Bow Window** is a group of identical wall segments that form a segmented curve. Select **Build> Window> Bow Window** and click on a straight wall to produce a 5-section bow window.

Bow windows can be composed of between two and twenty sections. The number of bow window components can be changed in the Bow Window Specification dialog. See [Bay/Box and Bow Window Specification Dialogs on page 613](#).

The component windows are specified in the Window Defaults dialog. Their sizes adjust to fit the available space.

The 5-section bow below has a 4'-10" radius centered 3'-9" inside the wall, giving an opening 5'-10" across and a depth of 11½".

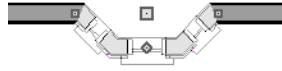

Note that for a bow with an odd number of sections, the radial dimension is from the center of the arc to an outside corner where two window sections join. The depth (11 ½") is measured to the flat area of the center section, not to a corner. As a result, the radius is a bit greater than the sum of the depth and the distance from the center of the bow's curve to the exterior of the wall.

Note: Bay, box, and bow window areas are not included in the living area or in room standard area calculations. They are included in room interior area calculations.

## PASS-THROUGHS

 Select **Build> Window> Pass-Through**, then click on a straight or curved wall to place a Pass Through at that location.

A Pass-Through is simply a wall opening without a window unit placed inside. Like a window, it can have casing and a sill. It does not, however, have a sash, frame, or glass. It is one of the window **Types** available in the Window Specification dialog. See [General Panel on page 592](#).

## WALL NICHE

 Select **Build> Window> Wall Niche**, then click on a straight or curved wall to place a Wall Niche at that location.

A Wall Niche is a wall opening that does not extend through the entire depth of the wall. You can specify the niche's depth in the Window Specification dialog. See [General Panel on page 592](#).

## WINDOWS LIBRARY

 Select **View> Library Browser**, then browse to Chief Architect Core Catalogs> Architectural> Windows to access a selection of special window units. Select the desired window, then click on a wall to place the window at that location.

---

# Special Windows

A variety of special windows can be created using multiple standard windows, the edit tools or custom symbols.

## CREATING MANUAL BAY, BOX AND BOW WINDOWS

Sometimes it is easier to draw bay, box and bow windows manually than to use the automatic tools. Bays created using walls can have more than one window per section, which is not possible using a bay window unit.

Bear in mind that moving a manually created bay, box or bow window is generally more difficult than moving a unit created with one of the **Window Tools**  since it is composed of individual walls.

## CORNER WINDOWS

To create a corner window, first create the desired window on each side of the corner. For best results, the heights, casing, and sills of both windows should be the same. For glass that meets at the corner:

- Specify both windows as **Fixed Glass**.
- Use each window's Move edit handle to position it all the way in the corner. To do this, drag the Move handle past the corner and parallel to the wall that the window is placed in. When the preview outline moves into the middle of the wall corner, release the mouse button.
- You can also position a window in a corner using its end Resize handle.
- Select **Mitered** in the Window Specification dialog. See *Frame Panel on page 598*.



Angled top, or shaped windows can be components of corner windows as long as their heights are equal at the corners. Windows with single or two segment tops can be used, but windows with three cannot. If a two segment window is used, the segment nearest the corner must be flat.

When a corner post is required, select **Post** instead of Mitered. There are a number of ways to control its size.



- Use dimensions to position the windows relative to the corner. By default, windows will stop when their interior casing bumps into the adjacent wall. See *Editing Windows on page 588*.
- To move a window all the way into a corner, check **Ignore Casing for Opening Resize**. See *General Plan Defaults Dialog on page 92*.
- To produce a minimal corner post and no siding or casing between the windows, use their Move edit handles. Click and drag each window past the exterior corner until its preview outline moves into the middle of the wall corner.

## SPECIAL WINDOW SHAPES

A selection of special shaped windows is available in the Windows Library, including arched windows and mullied units.

In addition, you can create a wide variety of window shapes in the Window Specification dialog, including:

- Arched windows. See *Arch Panel on page 603*.
- Trapezoidal windows. See *Shape Panel on page 601*.

- Round windows can be created by reflecting a Round Arch window vertically. See [Arch Panel on page 603](#).

## RECESSED WINDOWS

A window or muller unit placed in a brick or stone wall is often recessed into the wall's exterior, so the brick wraps the opening.

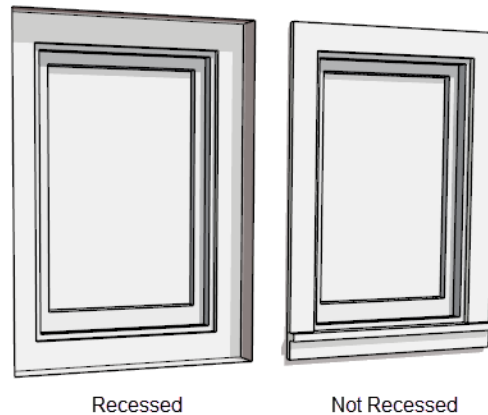

You can specify a window as recessed in the Window Specification dialog. See [Options Panel on page 593](#).

## WINDOW SYMBOLS

You can import custom windows and save them in your own library for use in future plans. See [Symbol Objects on page 978](#).

By default, window symbols are assigned the “Custom” Type in Window Schedules and in the Window Symbol Specification dialog, and they use automatic labels appended with the letters CU. The Type is derived from the Symbol Specification dialog, where you can also select the CAD block used to represent the symbol in plan view. See [Symbol Object Specification Dialogs on page 986](#).

## PLACING A GABLE OVER A WINDOW



Click the **Gable Over Door/Window** edit button to produce a gable roof over the selected window(s) the next time automatic roofs are built. See [Gable/Roof Lines on page 830](#).

You can manually edit or delete this gable line at any time. Your changes take effect when the automatic roofs are rebuilt. This tool can also be used with group selected windows.

## STAINED GLASS

A selection of solid stained glass materials is available in the Chief Architect Core Catalogs> Materials> Glass library. See [Materials on page 1049](#).

## VENTS

A selection of attic, foundation and gable vents are available in the Library Browser. See [The Library on page 945](#).

Vents are placed in the same manner as regular windows and can be edited in much the same way, as well.

---

## Grouped Windows

Windows can be grouped together to create a wide variety of custom configurations. Stacked windows are easy to create in 3D views, particularly cross section/elevation views, using their edit handles. See [Editing Windows on page 588](#).



Notice how the windows and door in this example are separate, with spaces between them. Doors and/or windows can also be organized into a unit in which there are no spaces between the windows and door units, and the casing between them is shared. To help organize their display in plan view, you can place stacked windows of varying heights on different Window Levels. See [Window Levels on page 585](#).

### AUTOMATICALLY MULLED OPENINGS

To form a mulled group of windows and/or doors, move them close enough together so that their casings touch. Once the casings touch, the windows are mulled together with one casing between the two of them.

The sill of each window in the group must be at the same level for them to share the middle casing; however, the casing tops do not. The casings are modeled as if they are one unit but the windows remain separate objects for dimensioning and the Materials List.

Windows can be automatically mulled to doors if the bottom of the window is at the elevation of the floor, equal to the bottom of the door.

The **Minimum Separation** value in the Window Defaults dialog specifies how close window and door units can be to each other. This setting also controls the width of the shared casing between adjacent windows. See [Window Defaults on page 577](#).

### MULLED UNITS IN THE LIBRARY

 A selection of mulled window units is available in the Windows library. To place one in your plan, select it and click on a wall in any view. See [Placing Library Objects on page 972](#).

### MAKE MULLED UNIT

 Windows and doors can be selected as a group and blocked together into a single unit by clicking the **Make Mulled Unit** edit button. See [Mulled Units on page 583](#).

### MULTIPLE STACKED OPENINGS

If four or more multiple windows or doors occupy the same space in a wall, a Caution  symbol will display at the problem location in plan view.

Click on the Caution  symbol that displays over the wall to open a contextual menu, then select **Delete Duplicate** to delete a duplicate opening. When no more Caution symbols remain, you should then confirm that the remaining three openings meet your needs and delete any that are unnecessary.

---

## Mulled Units

A mulled unit is a group of two or more windows and/or doors blocked together to form a single unit. A selection of mulled units is available in the Library Browser, and you can also create your own using the Make Mulled Unit edit tool.

### MAKE MULLED UNIT



The **Make Mulled Unit** edit tool allows you to block a group of selected windows and/or doors into a single unit.

Wall openings in a mulled unit are referred to as components. Components of a mulled unit must be within 24" (600 mm) of one another in order to become a blocked unit; however, their casings do not have to touch.

When created, mulled units use the default settings for all attributes they possess: for example, casing profile and materials. These attributes potentially override those of the individual components. Attributes that mulled units do not possess: for example, sash size and materials, are derived from each component.

Windows and doors in a mulled unit can be framed as a single opening or as multiple openings, and can be listed as a single unit or individual objects in the Materials List. See [Materials Lists on page 1303](#).

#### *To create a mulled unit*

1. Make sure that dimensions are set to locate Opening Sides, then use dimensions to position the windows and doors the desired distance apart. See [Moving Objects Using Dimensions on page 483](#).
2. In any view, group-select multiple windows and doors on the same wall that are within 24" of each other.
3. Click the **Make Mulled Unit**  edit button to create a block.

The **Make Mulled Unit**  edit tool can be used to block component windows and/or doors only if they meet the following requirements:



- They must be placed in the same wall.
- Adjacent objects be within 24" (600 mm) of one another (side to side or top to bottom).
- The edges of adjacent components that face one another must be parallel.
- The edges of adjacent components that face one another must be straight, not curved.
- The selected components can be adjacent vertically or horizontally, but not a combination of the two. Complex units can be formed only by mulling several blocks together.

Unlike automatically mulled openings, adjacent component edges of mulled units do not need to be the same length.

### MULLING STACKED OPENINGS

Group selection can be done in plan view or any 3D view. Plan views work well for blocking windows that are side-by-side, but a camera or elevation view is needed to block vertically stacked objects.

### ***To block stacked openings***

1. In a cross section/elevation view, select the door and the windows on level 1 and 2 above it, then click the **Make Mullered Unit**  edit button.
2. Repeat step 1 with the sidelight on the right and the window above it.
3. Repeat step 1 with the sidelight on the left and the window above it.
4. Group select the three vertically joined units and click the **Make Mullered Unit**  edit button to join them side to side.

The configuration of the horizontal and vertical mullions in a mullered unit will vary depending on the order in which you block stacked openings.

- If you form a mullered unit by first blocking objects vertically, the vertical mullions of the larger unit will extend continuously from the bottom to the top of the entire unit, breaking any horizontal mullions.
- If you form a mullered unit by first blocking objects horizontally, the horizontal mullions of the larger unit will extend from side to side, breaking any vertical mullions.

In a complex unit composed of smaller units, there may be a variety of ways to organize the sub-units.

### **SELECTING COMPONENTS OF MULLED UNITS**

To select a component of a mullered unit, click at the location of the component in question, then click the **Select Next Object**  edit button or press the Tab key until that individual component is selected. Only the component clicked on is selectable using this method. If you need to select a different component, click on it and repeat the process.

The selected component may be on any window level in the mullered unit. If there are multiple levels, it is easiest to select the components in a 3D view. When you have selected an individual component, you can change its parameters in the Window Specification dialog. See [Window Specification Dialog on page 591](#).

If the selected component is not itself a mullered unit and has no components above it, its **Height** and **Arch** parameters can be changed. Changing the Height causes the component top to move. The bottom remains stationary.

### **DISPLAYING MULLED UNITS**



As with other windows, the display of mullered window units is controlled in the Layer Display Options dialog. See [Layer Attributes on page 177](#).

Mullered units are placed on the “Windows” layer by default and have a single label, which is on the “Windows, Labels” layer. Mullered units are also included in the windows category of the Materials List and in window schedules. If the component objects of a mullered unit have unique moldings or materials, they will not be noted in the Materials List or in room finish schedules. See [Schedules and Object Labels on page 681](#).

If a mullered unit includes a door, **Treat as Door** will be checked in the Mullered Unit Specification dialog. When this box is checked, the unit’s default layer is “Doors” and its label is placed on the “Doors, Labels” layer. Units set to **Treat as Door** are also included in the “Doors” category of the Materials List, and these units’ Auto Schedule Category is “Mullered Door Units” instead of “Mullered Window Units”. Similarly, their casing is recognized as door casing in Room Finish Schedules. See [Options Panel on page 593](#).

You can, if you wish, display a mullered unit’s individual component labels instead of a single label for the unit. Labels are placed on the layers they would be on were the unit not mullered. A mullered unit’s label setting also affects how it is listed in schedules and in the Materials List. See [Label Panel on page 700](#).



- When **Suppress All Labels** is selected, individual components are counted in schedules and in the Materials List.
- When **Show Component Labels** is selected, components are counted in schedules and in the Materials List.
- When **Show Single Label for Entire Unit** is selected, the unit is treated as a single object in schedules and the materials list.

Mulled units can be placed on different Window Levels to control their appearance in plan view. See [Window Levels on page 585](#).

## EDITING MULLED UNITS

A mulled unit moves as a single standard window in both floor plan and 3D views.

The components of a mulled unit cannot be moved relative to one another. If this is required, you will first need to explode the mulled unit.

### *To explode a mulled unit*

1. Select the mulled unit.
2. Click the **Explode Mulled Unit**  edit button.

---

## Window Levels

It is often necessary to position more than one window, mulled unit, and/or door at the same location along a wall in plan view: for example, to create an entry with side lites and transom.



To help control and organize the appearance of stacked wall openings in plan view, you can assign windows at various heights to different **Window Levels**.

**Window Levels** do not define the height of a window, just the appearance and behavior of windows and doors in plan view.

- In plan view, windows and doors on the **Default Level** display the line color and style of the layer they are on. See [Layers on page 176](#).
- Windows on any other level appear light gray, regardless of the layer they are on.

## THE DEFAULT LEVEL

The **Default Level** is the Window Level that Standard Windows are initially placed on when created and affects several things:

- In plan view, windows and doors on the **Default Level** display the line color and style of the layer they are on.
- When you click on stacked doors and windows in plan view, those on the Default Level are selected first. To select an opening on another level, use the **Select Next Object**  edit button. See [Select Next Object on page 211](#).

Typically, the Default Level is set as 0 (zero).

## WINDOW LEVEL ZERO

**Window Level 0** (zero) is the level that all Bay, Box and Bow windows and doors are always placed on. Typically, it is also the Default Level that standard windows are placed on, as well.

Because doors are always on Level 0 and because Window Levels affect line colors in printouts, it is usually best to keep the Default Level at 0. If you do change the Default Level, remember to change it back before printing.

Once the window is created, its parameters, including Window Level, can be changed. See [Editing Windows on page 588](#).

In addition to using Window Levels to manage the appearance of stacked windows, you can combine them into a single blocked unit. See [Mulled Units on page 583](#).

---

## Displaying Windows



The display of windows and window labels in floor plan and 3D views can be controlled in the Layer Display Options dialog. See [Layer Display Options Dialog on page 179](#).

Along with the windows themselves, the display of a number of window components can also be controlled by layer:

- Interior and exterior window casings are located on the “Casings, Exterior” and “Casings, Interior” layers and can display in all views. In plan view, the sills and vertical side casings will be shown, but the horizontal top casing or lintel will not. If a window is recessed, the affected wall layers will adjust to accommodate the casing.
- Window and door shutters are located on the "Shutters" layer and can display in all views. Shutters can also be set to Show Closed or open. See [Shutters Panel on page 604](#).
- Window curtains and blinds are located on the "Windows, Curtains & Blinds" layer, which controls their display in camera views only. See [Treatments Panel on page 603](#).
- When the “Opening Header Lines” layer is turned on in plan view, headers are represented by dashed lines within each window. These lines do not correspond to actual framing objects and cannot be selected. In addition, header framing members can be set to display. See [Wall Framing on page 852](#).
- If a window is placed in a Garage room at a height where it extends into the stem wall or curb, a cutout in the concrete will display on the floor below. You can specify the cutout’s size and whether it displays in plan view in the Window Specification dialog. See [Rough Opening Panel on page 572](#).

If the “Windows” layer is not set to display, window casing and other components are not visible, but the openings in the walls where they are located can still be seen.

Windows can only be placed in walls, so if a wall’s layer is turned off in plan view, any windows placed in that wall will not display, either. Windows can display independent of their containing walls in 3D views, however. See [Displaying Walls on page 363](#).

## IN PLAN VIEW

A window’s frame, glass, and sill are all represented in plan view. This makes some window types, notably Sliding and Double and Triple Casement windows, distinguishable.

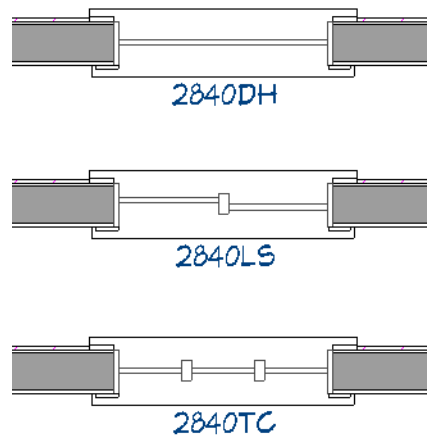

Window Types in plan view

By default, when a window is located entirely in one part of a pony wall, and that part is not displayed in plan view, the window's outline is shown but the wall's layer lines and fill drawn through it. You can instead display windows in the non-displayed parts of pony walls the same as in the displayed parts, or not at all. See *Pony Wall Defaults on page 345*.

Bay, box, and bow windows have dimensions lines associated with them.

- You can suppress their display by turning off the "Manual Dimensions" layer or on a unit by unit basis in the unit's specification dialog. See *Bay/Box and Bow Window Specification Dialogs on page 613*.
- The arrow style and fill are set in the Dimension Defaults dialog. See *Dimension Defaults Dialog on page 451*.

## IN 3D VIEWS

In addition to the components that are drawn in plan views, in camera views, interior and exterior window treatments display when the "Windows, Curtains & Blinds" layer is on. In 3D Vector Views, windows can also display opening indicator arrows. See *Opening Indicators on page 549*.

You can also specify whether window and door glass is opaque or transparent in the Rendering Technique Options dialog. When Opaque Window Glass is used, window and door glass uses the color specified for the active Rendering Technique. See *Rendering Technique Options on page 1153*.

## WINDOW LABELS

Window labels display in floor plan and cross section/elevation views, centered on the windows they represent, when the "Windows, Labels" layer is turned on and use the Text Style assigned to their layer. Similarly, Wall Niche labels display in the same manner when the "Wall Niches, Labels" layer is turned on. See *Label Panel on page 700*.

Automatic window and niche labels indicate Width and Height, followed by Type. For example:

- In U.S. Unit plans, the automatic label for a 3'-0" wide, 4'-0" high double hung window will read 3040 DH.
- In metric plans, the automatic label for a 900 mm wide, 1200 mm high double hung window will read 900x1200 DH.

If you prefer, you can use one of two other formats: Height/Width followed by Type and Width Only followed by Type. Label formats are specified in the Window Schedule Specification dialog or in the Window Schedule Defaults dialog if no schedule is present. See *Labels Panel on page 697*.

You can specify whether a Bay, Box or Bow Window displays a single label or displays the labels of its component windows. This choice will affect how the unit displays in schedules. See *Bay, Box, and Bow Windows on page 608*.

- When **Suppress All Labels** is selected, individual components of Bay, Box and Bow Windows are counted in schedules and in the Materials List.
- When **Show Component Labels** is selected, components of Bay, Box and Bow Windows are counted in schedules and in the Materials List.
- When **Show Single Label for Entire Unit** is selected, the Bay, Box or Bow Windows is treated as a single object in schedules but not in the materials list.

These options are also available for mullied units but affect their display in schedules and the materials list somewhat differently. See *Displaying Mullied Units on page 584*.

Customized labels using text and Object Specific Text Macros as well as label position and orientation can also be specified in the Window Specification dialog. See *Text Macros on page 540*.

## IN THE MATERIALS LIST

The materials associated with windows are listed under different Categories in the Materials List:

- **Windows** - Lists windows units, including Passthroughs.
- **Interior Trim** - Lists interior casing, lintels, aprons, and sills.
- **Exterior Trim** - Lists exterior casing, lintels, aprons, sills, and shutters.
- **Wall Board** - Lists the backerboard associated with Wall Niches.

As with other objects, there are a number of ways to control how, or whether, windows are included in the Materials List. See *Organizing Materials Lists on page 1310*.

You can add and edit information about a window's accessories in the Window Specification dialog. See *Components Panel on page 1330*.



## WINDOW SCHEDULES

 The **Window Schedule** tool is set up to produce customizable window schedules as well as window labels that display schedule numbers. Any schedule, however, can be set up to include windows. See *Schedules and Object Labels on page 681*.

In addition, any information about window casing and lintels can also be included in any schedule set up to include items in the Room and/or Molding categories. See *Room Finish Schedules on page 447*.

---

# Editing Windows

Before a window can be edited, it must be selected. Click on a window when the **Select Objects**  tool or any of the **Window Tools**  are active. Doors and/or windows can also be group-selected and edited. See *Selecting Objects on page 210*.

To select a window that is part of a blocked unit, click the component window, then click the **Select Next Object**  edit button. See *Selecting Components of Mullied Units on page 584*.

Once selected, windows can be edited using their edit handles, the Edit Toolbar buttons, and their specification dialogs.

## USING THE EDIT HANDLES

In plan view, click either of the two end handles and drag along the wall to change the width. The label showing the size updates as the window is resized.

In 3D views, a selected window has five edit handles: the Move handle at the center and a Resize handle on each edge. Click and drag an edge handle to resize the window. If window labels are set to display, they will each have a small square Move edit handle and a small rectangular Rotate handle. See [Displaying Windows on page 586](#).

Using the edit handles, a window resizes according to the currently active **Edit Behavior** . See [Defaults, Preferences, and Edit Behaviors on page 206](#).

In 3D views, a selected window has five edit handles: the Move handle at the center and a Resize handle on each edge. Click and drag an edge handle to resize the window.

In cross section/elevation views, window labels will also display when their layer is turned on, and will have the same edit handles as in plan view.

A single window or a group of windows can be moved with the center edit handle.

A door or window moved against an intersecting wall temporarily stops when it is the casing distance from the intersecting wall. Enable **Ignore Casing for Opening Resize** in the Plan Defaults dialog to turn off this behavior. See [General Plan Defaults Dialog on page 92](#).

You can continue to drag the selected window and it will resume movement past or onto the intersecting wall.

To create a corner window, drag the Move handle straight out past the wall corner, parallel to the selected window's wall. See [Corner Windows on page 580](#).

## IN THE SPECIFICATION DIALOG

 The most precise method of editing an individual window or group of windows is to use the Window Specification dialog. The window type, size, casing, materials, shape, and more can all be specified in this dialog. See [Window Specification Dialog on page 591](#).

You can apply a variety of window attributes to multiple windows - including bay, box, and bow windows - at once using **Style Palettes**. See [Style Palettes on page 279](#).

You can also use the **Object Painter**  tools to assign the properties of one window to other windows. The Object Painter tools do not affect bay/box/bow windows. See [Matching Properties on page 282](#).

## USING THE EDIT TOOLS

A selected window or windows can be edited in a variety of ways using the buttons on the Edit Toolbar. See [The Edit Toolbar on page 130](#).



**Gable Over Door/Window** creates a gable over the selected window(s) the next time the roof is rebuilt. See [Gable/Roof Lines on page 830](#).



**Change Wall Side** moves a selected Wall Niche to the opposite side of the wall. See [Wall Niches on page 579](#).



**Make Mull Unit** can be used to block multiple selected windows and/or doors into a single unit, while Explode Mull Unit breaks a mull unit into its individual components. See [Mull Units on page 583](#).

## USING DIMENSIONS



Like various other objects, windows can be moved using dimensions. See [Moving Objects Using Dimensions on page 483](#).

You can specify how windows and doors are located by dimensions in the Dimension Defaults dialog. Dimensions can be set to locate the centers, sides, casing, and/or rough openings of windows and doors, or you can choose to not locate them at all. See [Locate Manual Panel on page 454](#).

Once a dimension line has been drawn, you can move or add its extension lines to locate non-default locations on a window. See [Editing Extension Lines on page 478](#).

## WINDOW CASING, SILLS, AND MILLWORK

Windows often feature casing, or trim, on both sides of the wall opening as well as a sill on one or both sides. See [Moldings // Profiles / Rails / Panels on page 927](#).

The default casing for windows and doors is a basic rectangular stock profile. You can specify a window's casing profiles in the Window Specification dialog, or you can choose to suppress casing altogether. See [Casing Panel on page 563](#).

A separate molding profile can be specified for the lintel, or top horizontal molding. A sill profile can be specified, as well. See [Lintel Panel on page 595](#).

Additional millwork items can be applied above and below the window's casing on its exterior side. See [Treatments Panel on page 603](#).

Each of these objects can be replaced with a different profile or object directly from the library in 3D views. Select a molding profile or millwork item, then click on the window component you want it to replace. See [Replace From Library on page 976](#).

## WINDOW TREATMENTS AND SHUTTERS

Curtains and blinds can be assigned to the interior side of windows in the Window Specification dialog. See [Treatments Panel on page 603](#).

Shutters can be assigned to the exterior of windows in a similar manner. See [Shutters Panel on page 604](#).

Each of these objects can be replaced with a different object directly from the library in 3D views. Select a window treatment or shutter item, then click on the window component you want it to replace. See [Replace From Library on page 976](#).

---

# Custom Muntins







You can design your own muntins for the glazing of a window or door. Muntins are formed from a CAD block composed of lines and arcs drawn over window or door glass in a cross section/elevation view. The CAD block should cover at least half the glass horizontally and one quarter of the area vertically, but should not overlap it in either direction by more than five percent. Nested CAD blocks cannot be used. See [CAD Blocks on page 329](#).

## CREATING MUNTINS







Custom muntins are created by drawing their pattern using the CAD tools, blocking the pattern to create a CAD block, and then selecting the window and clicking the **Load Muntins** edit button.

### To create custom muntins

1. Create a **Cross Section/Elevation**  view of the wall the window or door is in and **Zoom**  in on the window or door.
2. Use the **Draw Line**  and **Draw Arc**  tools to design the desired muntins. Try to make them start and end as close to the edge of the glass as possible.
3. When the muntin design is complete, group-select all lines and arcs and click the **Make CAD Block**  edit button. See *Selecting Objects on page 210*.
4. Select the door or window and click the **Load Muntins**  edit button to convert the CAD block into custom muntins.
  - If the window in question is the component of a mulled unit, bay, or box window, click on it and, then click the **Select Next Object**  edit button.
  - If the window in question is the component of a bow window, the custom muntins will load onto all of its components - not just one of them.

If your window has more than one sash (a double-hung window, for example, has two), you must create a separate CAD block for each pane. When you click **Load Muntins** , all CAD blocks are loaded.

Custom muntins move with the opening and copy with their opening. They also stretch or compress when the glass area is resized. This stretching may not be perfect for non-rectangular glass areas that are resized by a large amount.

Custom muntins can be created for the components of **Bay Windows** , **Box Windows** , and mulled units. To create custom muntins for a **Bow Window** , you must draw them  on the one component that is selectable. When the muntins are loaded, they will be applied to all of the components See *Component Windows on page 609*.

The **Load Muntins**  edit tool can also be used to add custom muntins to glass doors. See *Special Doors on page 556*.



A selection of CAD blocks created for use as custom muntins is available in the library in Chief Architect Core Catalogs> Architectural> Windows> Custom Muntins.

### EDITING MUNTINS



Once blocked and loaded, custom muntins cannot be edited. If you wish to make changes to them, you must first remove them.

### REMOVING MUNTINS

-  Remove custom muntins from a door or window by selecting the opening in cross section/elevation view and clicking the **Unload Muntins** edit button. The muntins disappear and the original CAD block takes their place.

---

## Window Specification Dialog

-  To open the Window Specification dialog, select a window or a group of windows and click the **Open Object** edit button; or double-click the window using the **Select Objects**  or a **Window**  tool.

This dialog is also available for the components of Bay, Box, and Bow Windows. See *Bay, Box, and Bow Windows on page 608*.

You can also open the specification dialog for the window(s) associated with a schedule row. See *Open Row Object(s) on page 686*.

The settings in this dialog are similar to those in the Window Defaults dialog. See *Window Defaults on page 577*.

The settings in this dialog are also similar to those in the Wall Niche, Muller Unit and Window Symbol Specification dialogs. Although similar, a number of the options cannot be edited when either a window symbol or a muller unit is selected, and some panels are not available. See *Grouped Windows on page 582*.

The panels that are available in the Window Specification dialog will vary depending on whether the selected window is a regular window, a muller unit, or a symbol object.

## GENERAL PANEL

In the Wall Niche Specification dialog, only the **Size and Position** and **Include in Schedule** settings on this panel are available. See *Wall Niches on page 579*.

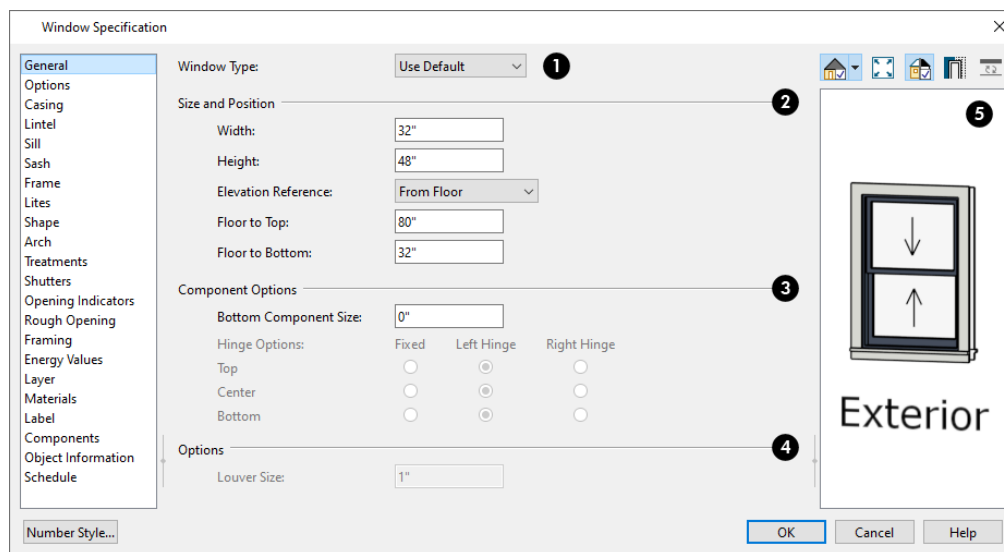

### 1 Window Type

Select the type of window from the list. The first entry in the list is the “Use Default”, which is set in the Window Defaults dialog.

### 2 Size and Position

- Specify the window’s **Width** and **Height**. These values do not include the window frame unless Window Size Includes Frame is selected on the FRAME panel.
- Select the **Elevation Reference** from the drop-down list. This determines where the next two settings are measured from and also affects their setting labels.
- Specify the height **to Top**, measured from the selected Elevation Reference to the top of the window frame.



- Specify the height to **Bottom**, measured from the selected Elevation Reference to the bottom of the window frame.
- Specify the **Depth** of the selected Wall Niche, measured from the wall surface to the back of the niche. Only available for Wall Niches.

Note: When either the Floor to Top or Floor to Bottom setting is modified, the other will adjust in response to prevent the window's Height from changing.

### 3 Component Options

These settings affect windows with movable sections and are not available for Pass-Throughs, Fixed glass windows, mullied units, or window symbols.

- Specify the **Bottom Component Size** for Single Hung, Double Hung, Double Awning, Double Hopper, and Triple Hopper windows; specify the **Top/Bottom Component Size** for Triple Awning windows; or,
- Specify the **Side Component Size** for Triple Casement and Triple Sliding windows, the **Right Component Size** for Left Sliding windows, or the **Left Component Size** for Right Sliding and Double Casement windows. A **Component Size** value of 0 creates a window with identically sized components.
- Specify how each **Component Opens** from the available options. Only available for Casement, Double and Triple Awning, and Double and Triple Hopper windows.

### 4 Interior Windows

These settings are only present when the selected window is a Pass-Through placed in an interior wall. See *Exterior and Interior Walls on page 351*.

- Check **Separate Trim and Materials for Each Side** to specify the casing, lintels, sills, and all materials for each side of the selected Pass-Through independently. When unchecked, the two sides use the same trim and materials.

### 5 Options

- **Louver Size** - Specify the vertical height of the selected window's louvers. Only available for Louvered and Glass Louver windows.
- Check **Include in Schedule** to include the selected window(s) in Window Schedules. See *The Schedule Tools on page 682*.

### 6 Preview

A preview of the selected window displays here. A label indicates which side of the window is its Interior and which is its Exterior. See *Dialog Preview Panes on page 22*.

Window opening directions can best be seen using the Vector View Rendering Technique.

## OPTIONS PANEL

The OPTIONS panel is not available in the Wall Niche Specification dialog.

The Mullied Units and Mullion Depth settings on the OPTIONS panel are only available in the Mullied Unit Specification dialog. See *Grouped Windows on page 582*.

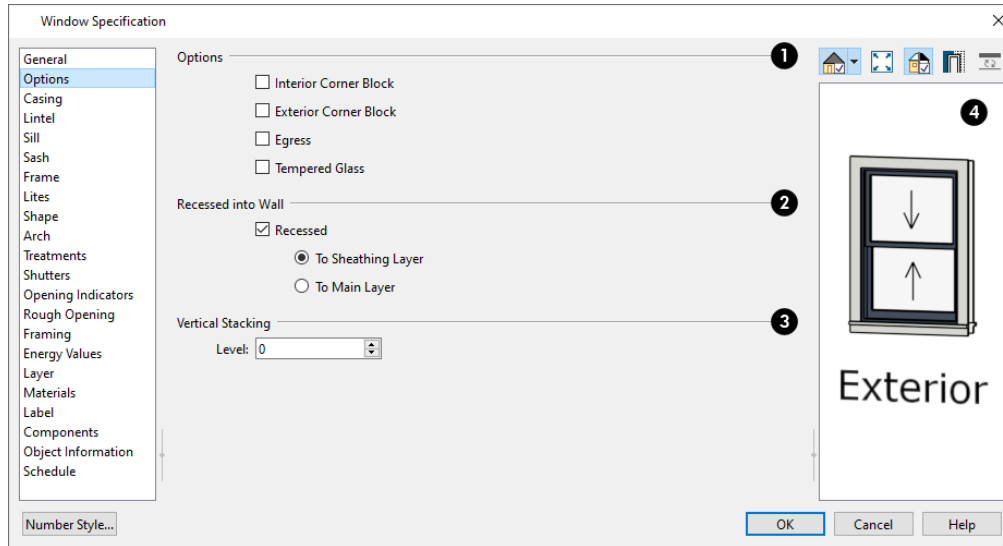

## 1 Options

- Check **Interior Corner Block** to count interior corner blocks in the materials list. These do not display in 3D views.
- Check **Exterior Corner Block** to count exterior corner blocks in the materials list. These do not display in 3D views.
- Check **Egress** to specify the window as an egress window in window schedules and the Materials List. Not available for Pass-Throughs.



Consult your local building and fire code authorities for your local egress window requirements.

- Check **Tempered Glass** to specify the selected window's glass as tempered in the Window Schedule. See *Columns to Include on page 689*.
- Check **Reverse Symbol** to reverse a window symbol as though it were reflected about a vertical line through its center. Only available in the Window Symbol Specification dialog. See *Window Symbols on page 581*.

## 2 Mullied Units

Only available when a mullied unit is selected. See *Make Mullied Unit on page 583*.

- Check **Treat as Door** to include the unit in the “Doors” category of the Materials List and in the “Mullied Door Units” Auto Schedule Category. Only available when the selected unit contains a door.
- Uncheck **Single Wall Hole** to produce individually framed wall openings for each unit in a mullied unit. When this box is checked, a single wall opening with one header for the entire unit is produced.

## 3 Mullion Depth

Specify the depth of the casing between the components of a mullied unit, measured from the wall surface. Positive values move the mullion surface towards the wall center; negative values, away from it. Only available when a mullied unit is selected.

- Specify the **Inside** depth of the mullion on the interior surface of the wall.
- Specify the **Outside** depth of the mullion on the exterior surface of the wall.

#### 4 Recessed into Wall

These settings allow you to recess the selected window or mullied unit into a wall, away from the exterior surface. Only available if the window or mullied unit is in a multi-layered wall.

- Check **Recessed** to enable the options below.

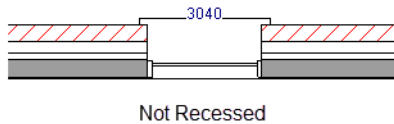

- Select **To Main Layer** to recess the window to the wall's Main Layer.

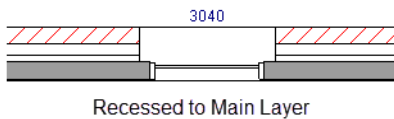

- Select **To Sheathing Layer** to recess the window to the wall's sheathing layer, which is the layer located just outside the wall type's Main Layer(s). See [Wall Type Definitions on page 384](#).

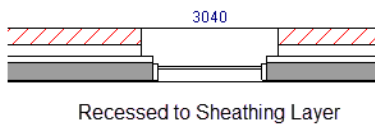

#### 5 Vertical Stacking

- Specify the window **Level** that the selected window is placed on. Not available for mullied units or window symbols. See [Window Levels on page 585](#).

#### 6 Preview

A preview of the selected window displays here. See [Dialog Preview Panes on page 22](#).

### CASING PANEL

The settings on the CASING panel of the Window and Mullied Unit Specification dialogs are also found on the panel of the same name in the Door Specification dialog. See [Casing Panel on page 563](#).

The CASING panel is not available in the Window Symbol Specification dialog.

Window casing and materials can be included in Room Finish Schedules. See [The Schedule Tools on page 682](#).

### LINTEL PANEL

The settings on the LINTEL panel of the Window and Mullied Unit Specification dialogs are also found on the panel of the same name in the Door Specification dialog. See [Lintel Panel on page 565](#).

The LINTEL panel is not available in the Window Symbol Specification dialog.

The profiles and materials of window lintels and sills can be included in Room Finish Schedules. See [The Schedule Tools on page 682](#).

## SILL PANEL

The settings on the SILL panel of the Window and Muller Unit Specification dialogs are not available if the window has a reflected arch. See [Arch Panel on page 603](#).

The SILL panel is not available in the Window Symbol Specification dialog.

The profiles and materials of window lintels and sills can be included in Room Finish Schedules.

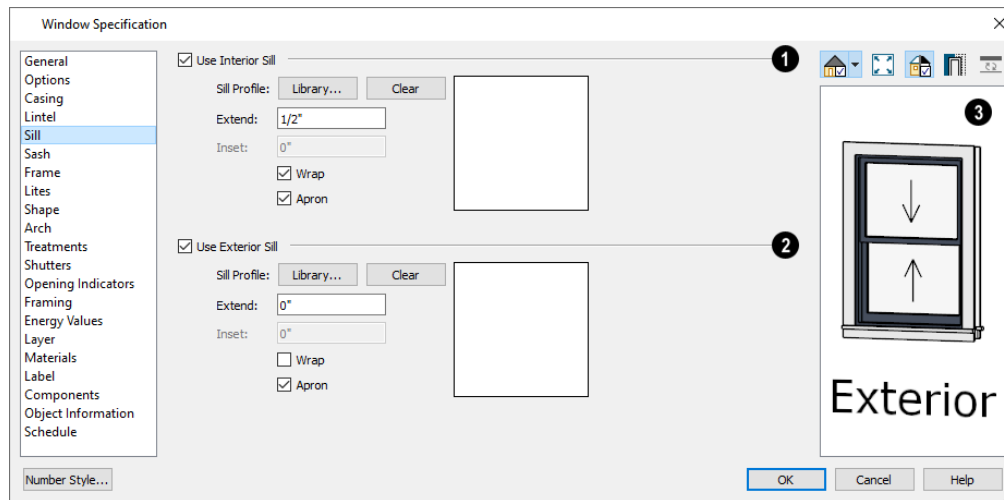

### 1 User Interior Sill

Check **Use Interior Sill** to enable the settings that follow, then specify the sill applied to the interior side of the selected window(s) using these settings. When this box is unchecked, no interior sill is used.

- **Sill Profile** - Click the **Library** button to select a molding profile for the sill. A preview of the selected profile displays to the right. See [Select Library Object Dialog on page 974](#).
- Click the **Clear** button to remove the selected sill profile from the window. When no library profile is selected, a basic rectangular profile is used.
- Specify how far to **Extend** the sill past the outside edges of the casing on each side. If an Apron is specified, it will also be affected by this setting.
- Specify how far to **Inset** the sill into the window. A value of 0 positions the sill profile against the surface of the wall. Only available when a sill profile from the library is selected.
- Check **Wrap** to wrap the sill profile back toward the wall.
- Check **Apron** to include an apron under the sill. When Wrap is checked, the apron will be 1/2" (12 mm) shorter than the sill on each side; when it is unchecked, it will be the same length as the sill.

### 2 Use Exterior Sill

Check **Use Exterior Sill** to enable the settings that follow, then specify the exterior sill for the selected window(s) using these settings. These settings are the same as those for the Interior Sill, above.

### 3 Preview

A preview of the selected window displays here. See [Dialog Preview Panes on page 22](#).

## SASH PANEL

The settings on the SASH panel control the size and position of the selected window's sash. Note that increasing the Side, Middle, Top or Bottom Width decreases the area of the glass and vice versa.

The SASH panel is not available in the Wall Niche, Muller Unit, and Window Symbol Specification dialogs, and the settings on this panel are not available for Pass-Throughs.

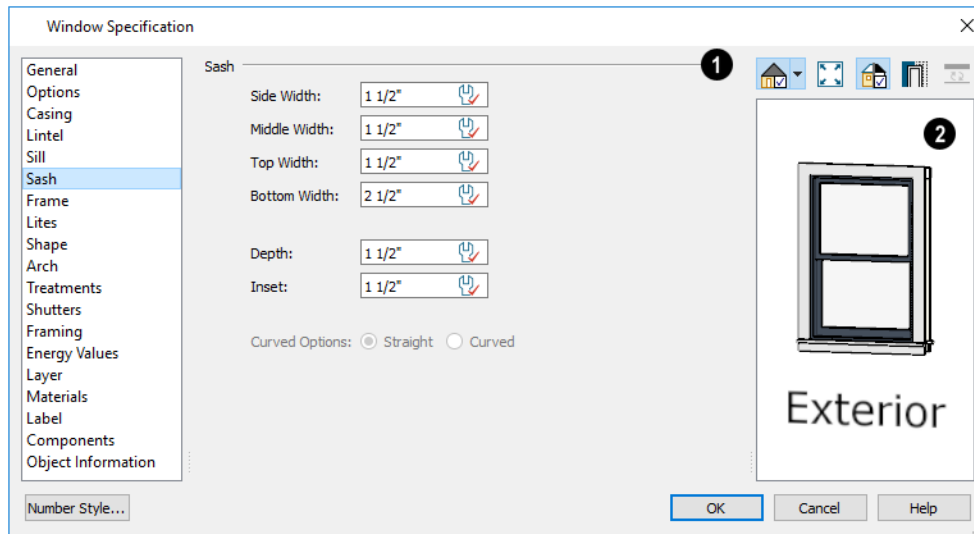

### 1 Sash

Specify the width and depth of the selected window's sash, which are the pieces of the window that hold the glass; or, uncheck this box to prevent it from having a sash.

- Specify the **Side Width** of all vertical sash members: those at the window sides as well as the central members of Casement and Sliding windows. This is also the width of the top portion of the window when an arch is specified.
- Specify the **Middle** width of horizontal components between the top and bottom sash in Double Hung, Double and Triple Awning, and Double and Triple Hopper windows. It does not affect Casement and Sliding windows.
- Specify the **Top** and **Bottom Widths**. The **Top** value is not used if the window has an arch.
- Specify the **Depth**, or thickness, of the sash stock measured from the exterior to the interior.
- Specify the **Inset**, the distance between the frame and the outermost sash. If there is no frame, the inset is measured from the outer surface of the wall's Main Layer.
- **Curved Options** - When the selected window is placed in a curved wall, specify whether it has a curved or straight sash. A curved sash is typically used with Radial casing. See *Casing Panel on page 563*.

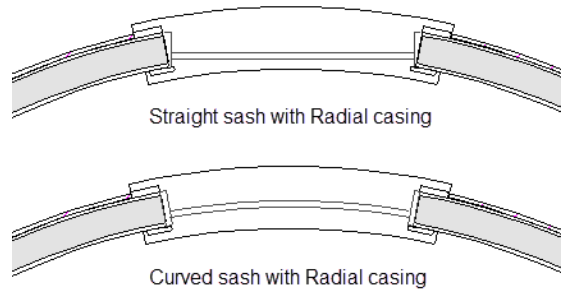

## 2 Preview

A preview of the selected window displays here. See *Dialog Preview Panes on page 22*.

## FRAME PANEL

The FRAME panel is not available for mullied units or window symbols. The settings on the FRAME panel are similar to those on the JAMB panel of the Door Specification dialog. See *Jamb Panel on page 566*.

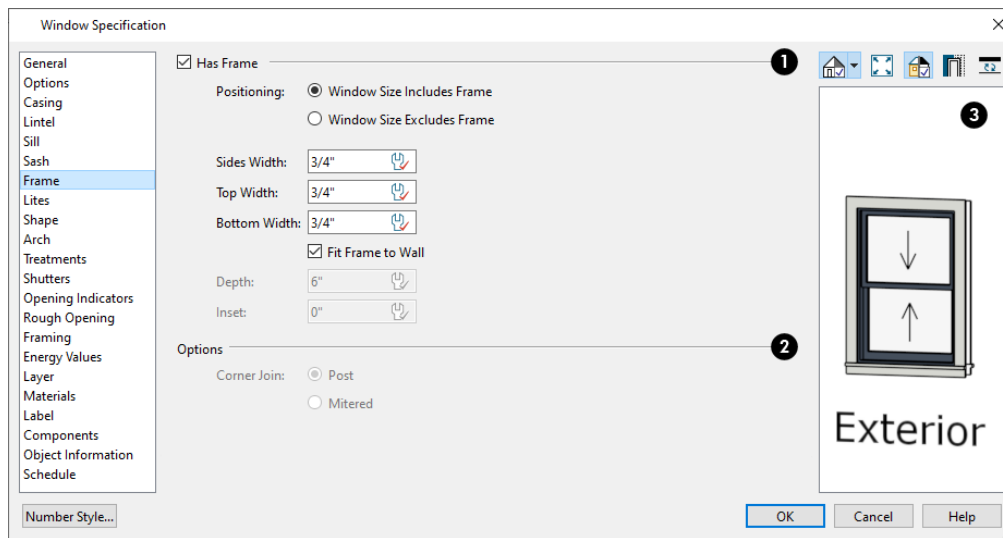

## 1 Has Frame

Check **Has Frame** to include a frame and enable the settings below. When this is unchecked, the selected window has no frame around it.

- Specify the **Positioning** of the window frame. These settings affect what the window's Size settings on the GENERAL panel are describing; however, switching these settings does not affect the Size values:
  - Select **Window Size Includes Frame** to specify size as a total of the window glass plus sash plus jamb width.
  - Select **Window Size Excludes Frame** to specify the size of the window glass plus sash only.
- Specify the **Side**, **Top**, and **Bottom Widths** of the window's frame. Changing these values only affects a window's total size when Window Size Includes Frame is selected, above.

- Uncheck **Fit Frame to Wall** to specify the Depth and Inset of the selected window’s frame. When this box is checked, the frame Depth automatically extends from the Recessed Into Wall layer to the wall’s inside surface with an Inset of 0”. The Recessed Into Wall layer is specified on the *Options Panel on page 593* of this dialog.
- Specify the **Depth** of the window frame from front to back.
- Specify the frame’s **Inset**, which is measured from the Recessed Into Wall layer and moves the window frame towards its interior side. If used, the casing and lintel are not affected by this setting.

## 2 Options

Specify how corner windows join. Only available when the selected window is one of two Fixed glass windows that meet at a wall corner, or when both windows are selected. See *Corner Windows on page 580*.

- Select **Post** to produce a vertical support between the two windows that separates their sash and glass.
- Select **Mitered** for sash and glass that meet and miter at the corner where the two windows meet.

## 3 Preview

A preview of the selected window displays here. See *Dialog Preview Panes on page 22*.

## LITES PANEL

The LITES panel allows you to add muntins to windows, and is also available for Glass doors. See *Doors on page 543*.

There are four possible styles of muntin bars for regular windows, plus two additional options for arched windows.

A window that has been modified using the SHAPE panel cannot have divided lites or shutters added. You can, however, create Custom Muntins for such a window. See *Custom Muntins on page 590*.

The LITES panel is not available in the Wall Niche, Muller Unit, and Window Symbol Specification dialogs, and the settings on this panel are not available for Pass-Throughs.

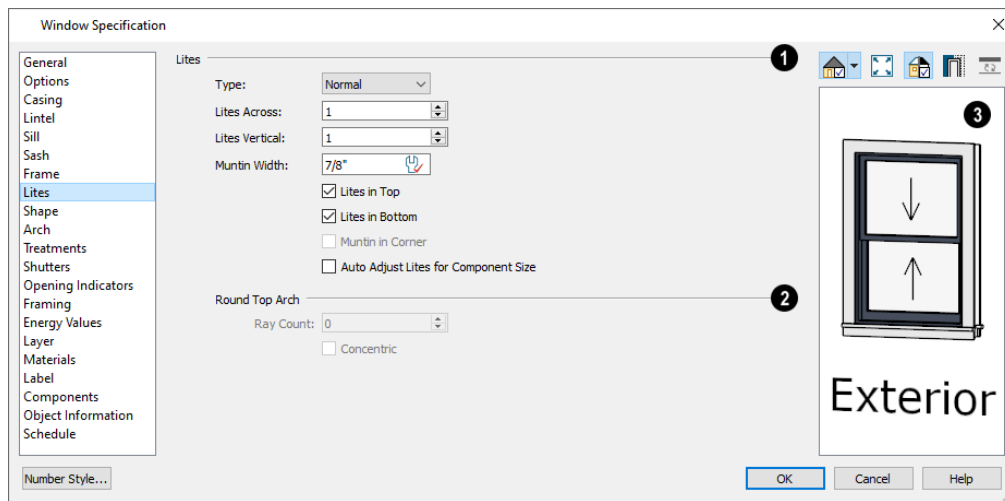

## 1 Lites

Specify the number, position and style of lites for the selected window.

- Select a **Type**, or style, of window lite from the drop-down list.

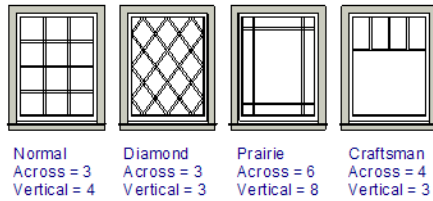

- **Normal** style is the most common, with muntins going horizontally and vertically. Colonial windows are an example of the normal style.
- **Diamond** style uses angled muntin bars to divide up the lites. French windows are an example of the diamond style.
- **Prairie** style is based on the normal style, but with all the central muntin bars removed, leaving only the two outside muntin bars both horizontally and vertically. Typically, both Lites Across and Lites Vertical should be set between 6 and 8. Federal or Federation windows are an example of the Prairie style.
- **Craftsman** style is based on the normal style, but only the topmost horizontal muntin bar is kept with all the portions of the vertical muntin bars above it. Typically, both Lites Across and Lites Vertical should be set between 4 and 8.
- Enter the number of horizontal **Lites Across** in each sash.
- Enter the number of vertical **Lites Vertical** in each sash.
- Specify the **Muntin Width**, which is the width of the bars dividing the panes of glass.
- Check or uncheck **Lites in Top** and/or **Lites in Bottom** - or **Lites in Left** and/or **Lites in Right** - to specify either one or both of the sashes to have divided lites.
- Check **Muntin in Corner** to add a vertical muntin bar where two corner windows meet. Only available when Has Corner Post is unchecked on the FRAME panel. See *Corner Windows on page 580*.
- Check **Auto Adjust Lites for Component Size** to have the program produce lites that are consistent in size across all components. When this is checked, the window's lites and its specification settings may not agree; when unchecked, lites in the components may not be consistent in size.
- Note: Because the fixed window in a Triple Sliding window is twice the size of the movable windows, the fixed section has a vertical muntin bar. To eliminate this, uncheck Auto Adjust Lites for Component Size.

## 2 Round Top Arch

These options are only available if the window has an Arch specified.

- Specify a **Ray Count** of up to 10 radial muntin bars in the portion of the window within the arch. There is one more pane of glass than the number of rays specified. See *Arch Panel on page 603*.
- Check **Concentric** to produce muntins radiating from a curved inner muntin that is concentric with the window's arch. You must have at least three Lites Across for this to be used.



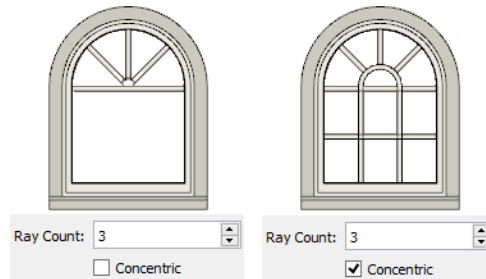

### 3 Preview

A preview of the selected window displays here. See *Dialog Preview Panes on page 22*.

### SHAPE PANEL

The settings on the SHAPE panel control the position of the selected window’s corners, allowing you to create angled edges and mitered top corners.

If any of these settings are used to create a custom shape, the selected window will be automatically specified as “Fixed Glass” on the GENERAL panel. If the selected window has an arch specified on the ARCH panel, it will be removed.

The SHAPE panel is not available for mullied units or window symbols.

Note: The Left and Right settings on this panel refer to the window’s exterior.

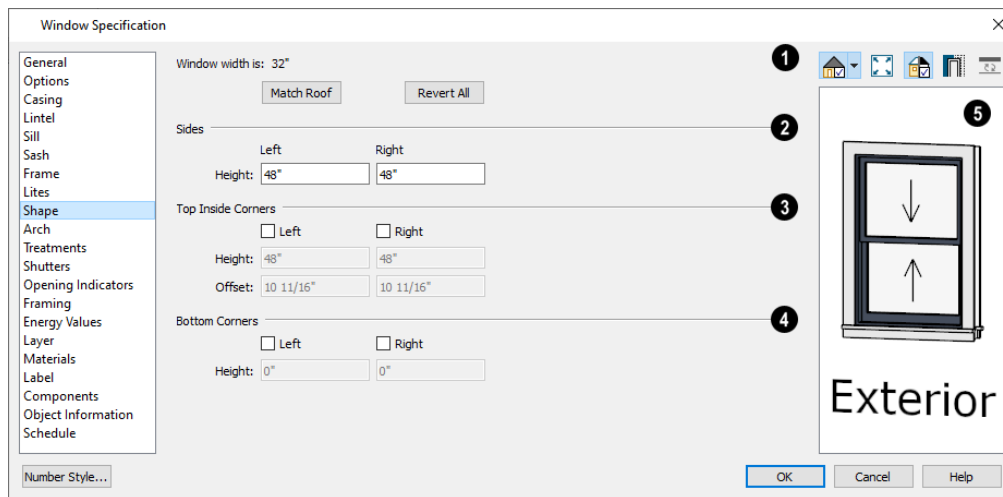

### 1 Window Width

The Window Width displays for reference here. It can be changed on the *General Panel on page 592*.

- Click **Match Roof** to match the angle of the top of the window to the pitch of the roof above by changing its Sides heights, below. If either Top Inside Corner box is checked, it will become unchecked.

Match Roof does not work for curved roofs, has no effect if the window is not in a gable end wall, and is not available in the Window Defaults dialog.

- Click **Revert All** to restore the window to its original shape, type and arch settings.

## 2 Sides

Specify the height of the window's **Left** and **Right** sides, as measured from the bottom of the window. By default, these settings match the window's Height.

## 3 Top Inside Corners

These settings allow you to create a second set of top corners with angled edges between them and the outside top corners.

- Check **Left** to add an additional corner along the top edge.
- Specify the **Height** of the left inner corner, as seen from the exterior, measured from the bottom of the window.
- Specify the **Offset** of the left inner corner, as measured from the left side of the window.
- An additional **Right** Inside Corner can be specified in a similar manner.

## 4 Bottom Corners

These settings allow you to raise the heights of the bottom corners, as measured from the bottom of the window specified on the *General Panel on page 592*.

- Check **Left** to raise the height of the bottom left corner.
- Specify the **Height** of the bottom left corner. This value cannot exceed the Height of the Left Side.

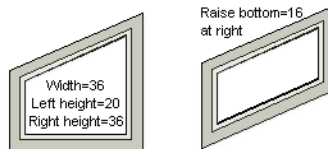

- The height of the **Bottom Right** corner can be raised in a similar manner.

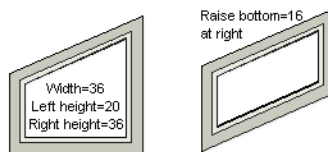

- The height of the **Bottom Right** corner can be raised in a similar manner.

## 5 Preview

A preview of the selected window displays here. You may want to rotate the view so the window's exterior can be seen. See *Dialog Preview Panes on page 22*.

Note: The Left and Right settings on this panel refer to the window's exterior.

The following diagram represents added Inner corners using open circles and the left and right corners using solid black circles:

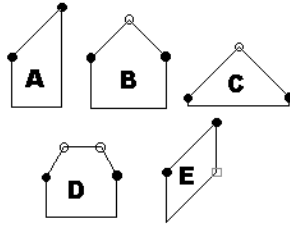

- A has different left and right Side Heights with no Top Inside Corner added.
- B has matching left and right heights with an added Top Inside Corner.
- C is the same as B, except that the left and right Side Heights have been shortened to 1/4”.
- D is the same as B except it has two added Top Inside Corners.
- E is the same as A except that the Bottom Right Corner has been raised.

## ARCH PANEL

The settings on the ARCH panel of the Window and Mulled Unit Specification dialogs are also found on the panel of the same name in the Door Specification dialog. See [Arch Panel on page 567](#).

The settings on this panel of the Muller Unit Specification dialog define the overall shape of the blocked unit’s top. If the muller unit already includes a component window with an arch, these settings cannot be modified. If you intend to arch the top of a muller unit, the top components should be constructed with horizontal, straight tops all at the same height.

The ARCH panel is not available for window symbols, and its settings are not available if the selected window has been modified using the SHAPE panel.

## TREATMENTS PANEL

The settings on the TREATMENTS panel allow you to add embellishments to the interior and exterior of the selected window or muller unit.

The TREATMENTS panel is not available in the Wall Niche and Window Symbol Specification dialogs.

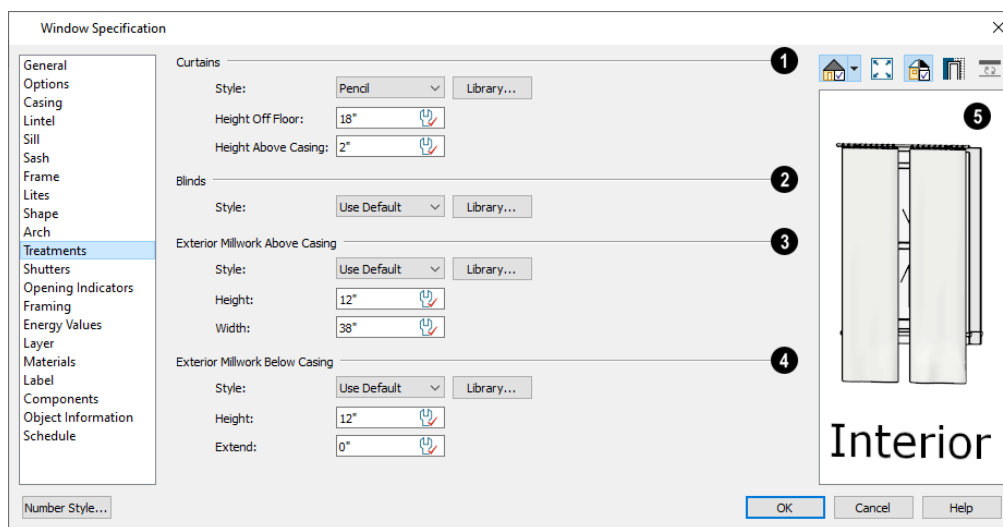

### 1 Curtains

Curtains are applied to the selected window or muller unit’s interior side.

- Specify a style of **Curtains** by selecting “Use Default”, “None” or “Library” from the drop-down list. If a non-default library item has been selected, its name will display in the list, as well.
- Click the **Library** button or select “Library” from the drop-down list to choose a style of curtain from the library. See *Select Library Object Dialog on page 974*.
- Specify the **Height Off Floor** of the bottom edge of the curtains.
- Specify the **Height Above Casing** of the top of curtains.

## 2 Blinds

Blinds are specified in the same manner that Curtains are chosen, above.

## 3 Exterior Millwork Above Casing

Exterior millwork above the casing can be specified in the same manner that Curtains are chosen, above.

- Specify the selected millwork's **Height** and **Width**.

## 4 Exterior Millwork Below Casing

Exterior millwork below the casing can be specified in the same manner that Curtains are chosen, above.

- Specify the **Height** of the millwork and the distance that it should **Extend** past the side casing.

## 5 Preview

A preview of the selected window displays on the right. You may want to rotate the view so the window's interior can be seen, as needed. See *Dialog Preview Panes on page 22*.

## SHUTTERS PANEL

The settings on the SHUTTERS panel allow you to specify exterior shutters for the selected window or muller unit.

The SHUTTERS panel is not available in the Wall Niche and Window Symbol Specification dialogs.

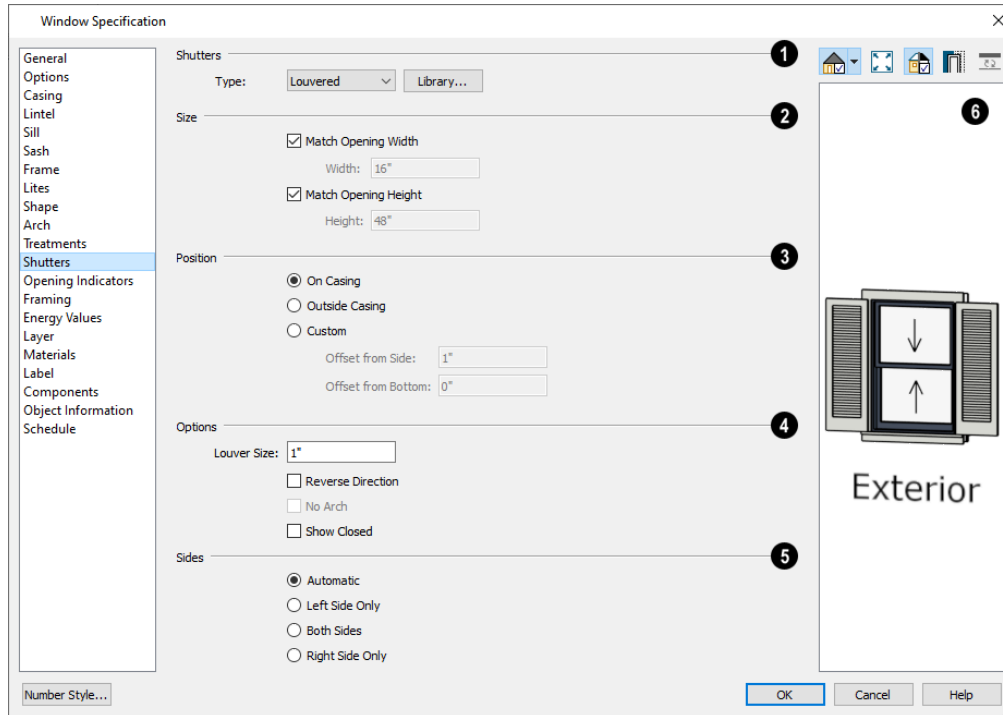

### 1 Shutters

Select a **Type** of shutters from the drop-down list or click the **Library** button to select a style of shutters from the Library Browser. See [Select Library Object Dialog on page 974](#).

### 2 Size

- When **Match Opening Width** is checked, each shutter's width is exactly half that of the window, excluding casing.
- Uncheck **Match Opening Width** to specify a **Width** in the text field. If the window is later resized, the shutters will not adjust in response.
- When **Match Opening Height** is checked, each shutter's height equals that of the window, excluding casing.
- Uncheck **Match Opening Height** to specify a **Height** in the text field. If the window is later resized, the shutters will not adjust in response.

### 3 Position

Specify the position of the shutters relative to the window.

- Select **On Casing** to position the shutters just outside the window frame, like functional shutters.
- Select **Outside Casing** to position shutters outside the window casing, as decorative shutters often are.
- Select **Custom** to create a custom position for the shutters by specifying the **Offset from Side** and **Offset from Bottom** in the fields below.

### 4 Options

Additional shutter **Options** can be specified here.

- Specify the **Louver Size**. Only available when "Louvered" is selected as the Type, above.
- Check **Reverse Direction** to orient the shutters so their exterior sides face outward and their interior sides face the wall. For functional shutters, this should remain unchecked.
- Check **No Arch** for shutters with flat tops that reach the bottom of the curved portion of an arched window. Only available when an Arch is selected. See *Arch Panel on page 603*.
- Check **Show Closed** to draw the shutters so they cover the exterior of the selected window. When this is unchecked, the shutters are positioned against the wall on either side of the window.

## 5 Sides

Specify which sides of the selected window receive shutters.

- Select **Automatic** to assign shutters to both sides of the window as long as there is sufficient room on the wall. If the window is next to a wall intersection or corner, the shutter closest to the intersection will not generate.
- Select **Left Side Only** to assign a shutter to the left side of the window and none on the right.
- Select **Both Sides** to assign shutters to both sides of the window under all circumstances, even if there isn't enough room on the wall for one or both of them.
- Select **Right Side Only** to assign a shutter to the right side of the window and none on the left.

## 6 Preview

A preview of the selected window displays on the right. Shutters will only generate if there is sufficient room for them along the window's containing wall. In order to see the shutters, you may need to rotate the preview to show the Exterior. See *Dialog Preview Panes on page 22*.

## OPENING INDICATORS PANEL

The settings on the OPENING INDICATORS panel are also found on the panel of the same name in the Door Specification dialog. See *Opening Indicators Panel on page 570*.

## ROUGH OPENING PANEL

The settings on the ROUGH OPENING panel are also found on the panel of the same name in the Door Specification dialog. See *Rough Opening Panel on page 572*.

## FRAMING PANEL

The settings on the FRAMING panel are also found on the panel of the same name in the Door Specification dialog. See *Framing Panel on page 573*.

## ENERGY VALUES PANEL

The settings on the ENERGY VALUES panel let you specify information used for export to REScheck. See *Export to REScheck on page 1240*.

This panel is not available in the Wall Niche Specification dialog.

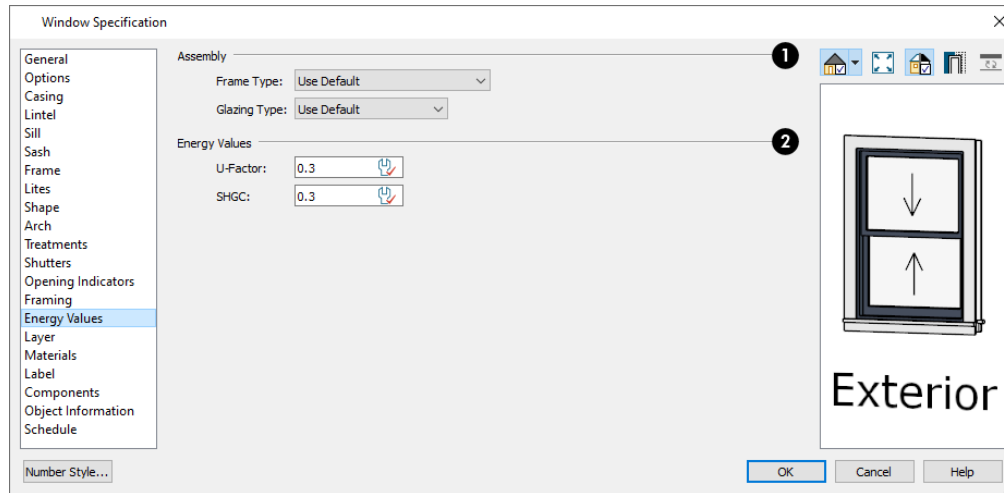

## 1 Assembly

- Select a **Frame Type** and **Glazing Type** from the drop-down lists.
- In the Door Specification dialog, instead select a **Door Type** from the drop-down list.

## 2 Energy Values

- Specify the selected window's **U-Factor**.
- Specify the selected window's **SHGC** (Solar Heat Gain Coefficient).

## LAYER PANEL

The settings on the LAYER panel are the same as those found on the same panel in dialogs throughout the program. See [Layer Panel on page 186](#).

## MATERIALS PANEL

The settings on the MATERIALS panel are the same as those found on the same panel in dialogs throughout the program. See [Materials Panel on page 1055](#).

The settings on the MATERIALS panel of the Muller Unit Specification dialog apply to all components of the blocked unit. Any settings made for individual components of the blocked unit are overridden here.

## LABEL PANEL

Window labels display in plan view and cross section/elevation views when the “Windows, Labels” layer is turned on and use the Text Style assigned to that layer. See [Window Labels on page 587](#).

Similarly, Wall Niche labels display in plan view and cross section/elevation views when the “Wall Niches, Labels” layer is turned on and use the Text Style assigned to that layer. See [Window Labels on page 587](#).

For more information about the settings on this panel. See [Label Panel on page 700](#).

## COMPONENTS PANEL

The information on the COMPONENTS panel can be used in the materials list. For more information, see [Components Panel on page 1330](#).

## OBJECT INFORMATION PANEL

The information entered on the OBJECT INFORMATION panel can be used in schedules and the materials list. For more information, see [Object Information Panel on page 1331](#).

## SCHEDULE PANEL

The settings on the SCHEDULE panel determine which schedule categories the selected window is included in. See [Schedule Panel on page 704](#).

## MANUFACTURER PANEL

The MANUFACTURER panel provides contact information for the selected window's manufacturer. Only available for windows from Manufacturer library catalogs. See [Manufacturer Catalogs on page 961](#).

---

# Bay, Box, and Bow Windows



Bay, Box and Bow Windows are created much the way regular windows are: select a tool, then click a wall to place that window type.

Chief Architect automatically builds a foundation under bay/box/bow windows placed on Floor 1 unless they are raised from their original position. That section of the foundation wall is also a bay/box/bow, but without windows. If the foundation was generated before the window is placed, the foundation must be rebuilt or edited manually.

## DISPLAYING BAY, BOX, AND BOW WINDOWS

The display of bay, box, and bow windows is controlled in the Layer Display Options dialog. See [Layer Display Options Dialog on page 179](#).

Like other windows, bay, box, and bow windows can display labels. Either a single label for the unit can be used, or a separate label for each component. See [Window Labels on page 587](#).

Bay, box, and bow window width and radius dimensions, which display in plan view when specified to do so in the window's specification dialog, are placed on the "Dimensions" layer. See [Options Panel on page 615](#).

## EDITING BAY, BOX, AND BOW WINDOWS

Bay, box, and bow windows are edited similar to regular windows with one exception: in plan view, a diamond-shaped Depth edit handle displays on the section. Drag this Depth handle outward to increase the depth, or inward to decrease the depth of the unit. See [Editing Windows on page 588](#).



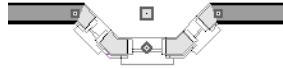

Bay, box, and bow windows can also be edited in their respective specification dialogs. See [Bay/Box and Bow Window Specification Dialogs on page 613](#).

A variety of style attributes can be assigned to bay/box/bow windows using **Style Palettes**. See [Style Palettes on page 279](#).

## COMPONENT WINDOWS

A component window within a bay, box, or bow window can be edited like others standard window, with a few restrictions. To select a component window, click at the location of the component in question, then click the **Select Next Object**  edit button or press the Tab key.

- Only the bay or box window component that was clicked on is selected using this method. If you need to select a different component, click on it and repeat the process.
- In a bow window, all components are identical, so only one component can be selected. Changing this component changes them all.

An individual component window can be resized using the edit handles or by changing settings in the component's Window Specification dialog. Component windows can also be resized using the Transform/Replicate Object dialog. See [Transform/Replicate Object Dialog on page 266](#).

When a bay/box/bow window is first created, there is room for one standard trimmer on each side of each component window. When the bay as a whole is moved and resized, its components automatically resize so that a standard trimmer is still accommodated.

If you increase a component window's width to the point where there is not enough room for standard trimmers, a thinner trimmer can be used. The size of this thinner trimmer is specified in the Build Framing dialog. See [Openings Panel on page 865](#).

If a component window is resized, it retains its size if at all possible when the containing bay/box/bow window is moved or resized. If the bay is resized in such a way that the component is too large to fit even with a thinner trimmer, the component resumes its default behavior, resizing as the containing bay window is resized.

## FLOORS AND CEILINGS

When originally created, the floor and ceiling within a bay, box, or bow window are the same heights as the floor and ceiling of the room in which it is placed.



Both the top and bottom heights of these window units can be adjusted in its specification dialog or a 3D view using its edit handles to create a lowered ceiling and/or a bench seat or garden window.



When the ceiling is lowered, the top heights of the walls that define the window unit are also lowered. When a roof is built over the unit, its height will be affected, as well.

When the bottom of the window is raised to create a bench seat, the unit's walls will not reach the ground. As a result, window units with bench seats will have no foundation beneath them when the foundation is built.

## EXPLODE BAY/BOW WINDOW

 Click the **Explode Bay/Bow Window** edit button to explode a selected Bay/Box/Bow Window into its component parts. The walls and windows can be edited individually and, if the original window had a Lowered Ceiling or Raised Floor, a new, editable room will be also created.

Walls created when the **Explode Bay/Bow Window** tool is used will have **Treat As Part Of Bay/Bow/Bow Window** checked in the Wall Specification dialog, which affects how the roof above is generated. See [Roof Panel on page 398](#).

Rooms created when this tool is used will have **Raised Floor For Bump Out** checked in the Room Specification dialog, allowing its floor platform to build independent of the ceiling of a room on the floor level below. See [Structure Panel on page 439](#).

Once exploded, it is not possible to block the components into a Bay/Box/Bow Window object again.

---

## Bay, Box, Bow Windows and Roofs

Several different roof styles can be specified for Bay, Box and Bow window units in the Bay/Box and Bow Specification dialogs. See [General Panel on page 613](#).

If you change a Bay, Box, or Bow Window's roof specification, you will need to rebuild the roofs to see the changes. See [Rebuilding Roofs on page 796](#).

## HIP ROOFS

By default, a hip roof is built above the unit when roofs are automatically generated. Bay and Bow Windows with angled side walls also receive two additional roof planes that produce a ridge at the back of the bump-out's roof, sometimes referred to as a California ridge. No roof directives need to be selected in the Bay/Box/Bow Specification dialog to produce this roof.



Hip roofs over Bay, Box, and Bow Windows

### USE THE EXISTING ROOF

To generate a standard roof that ignores a Bay, Box, or Bow Window, check **Use Existing Roof**.

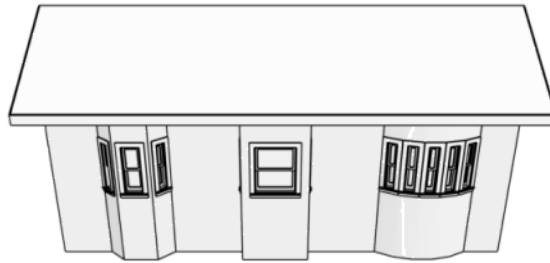

Existing roof extending over and following the shape of Bay, Box, and Bow Windows

With this option the Bay, Box, or Bow Windows is tucked under the roof eave. You may find it necessary to increase the width of the eave. See [Roof Panel on page 798](#).

### EXTEND THE EXISTING ROOF

To have the main roof extend down over the window unit and follow the shape of the unit, select **Extend Existing Roof Over**.



Existing roof extending over and following the shape of Bay, Box, and Bow Windows

To extend the main roof down over a window unit to create a rectangular roof over it rather than one that follows its shape, select both **Extend Existing Roof over** and **Rectangular Roof Over**.

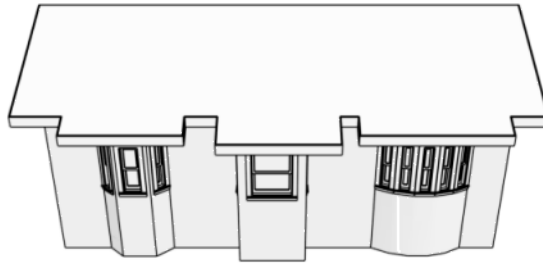

Existing roof extending rectangular bump-outs over Bay, Box, and Bow Windows

For this roof style, the ceiling heights of the window unit and the adjacent room must be the same. If you lower the ceiling of the window unit and then build the roof, a lower hip roof over the window is created. See [Floors and Ceilings on page 609](#).

If a header is desired over the window unit, first build the roof, then lower the ceiling of the window unit. Once the ceiling is lowered, select **Rebuild Walls/Floors/Ceilings** . Do not rebuild roof planes.

## RECTANGULAR HIP ROOFS

To create a rectangular-shaped hip roof above a Bay, Box, or Bow window, select **Rectangular Roof Over**.



Rectangular-shaped hip roofs over Bay, Box, and Bow Windows

## GABLE ROOF

A gable roof is not one of the automatic options for the roof above a Bay, Box, or Bow Window. A gable can be created by manually editing the rectangular hip roofs that are automatically created. See [Roof Planes on page 804](#).

### ***To create a gable over a bay window***

1. Select a Bay, Box, or Bow window, open its specification dialog, and choose the **Rectangular Roof Over** option.
2. Rebuild the roof.
3. Select one of the side roof planes and drag the corner edit handle located at front end of the ridge forward until the fascia snaps to the edge of the front hip section.
4. Edit the other side roof plane in the same manner.
5. Delete the front hip section.
6. Adjust the roof's overhang as needed.



 To create a gable roof over a normal window, use the Gable Over Door/Window edit button. See [Gable/Roof Lines on page 830](#).

## Bay/Box and Bow Window Specification Dialogs

To open the Bay/Box Window Specification or the Bow Window Specification dialog, select one or more Bay, Box, or Bow Windows and click the **Open Object** edit button. See [Bay, Box, and Bow Windows on page 608](#).

The options in this dialog can only be set for objects placed in a plan: Bay, Box, and Bow Windows do not have defaults dialogs.

The settings that are available in these dialogs depend on whether the selected object is a Bay, Box, or Bow Window.

The Bay/Box and Bow Window Specification dialogs have the following panels:

### GENERAL PANEL

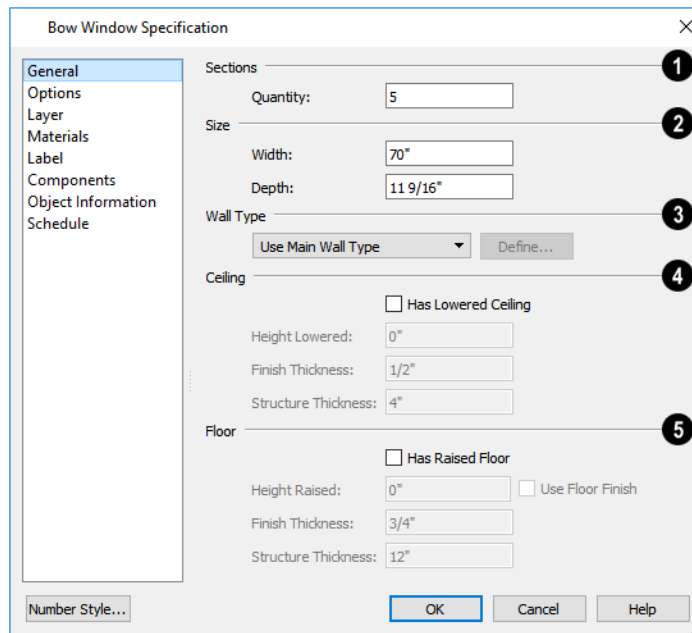

#### 1 Sections

The setting that displays here depends on whether the selected window is a Bay, Box, or Bow Window.

- Specify the **Bay Angle**, which is the angle of the side components of a Bay or Box Window. Bay Windows have an angle of 45° by default; Box Windows have an angle of 90°.
- Specify the **Quantity**, which is the number of component windows in a Bow Window.

## 2 Size

Specify the **Width** and **Depth** of the Bay, Box, or Bow Window.

## 3 Wall Type

Specify the Wall Type used by the walls embedded in the selected Bay, Box, or Bow Window. See *Wall Type Definitions on page 384*.

- Select “Use Main Wall Type” from the drop-down list to use the same wall type as that of the wall that the window unit is placed in. If the main wall is a Pony Wall, both wall types are used.
- Select a specific wall type from the drop-down list to use it instead of the Main Wall Type.
- When a specific wall type is selected, click the **Define** button to modify its definition. See *Wall Type Definitions Dialog on page 387*.

## 4 Ceiling

Specify the height and structure of the **Ceiling** within the selected window.

- Check **Has Lowered Ceiling** to enable the settings that follow. When this is unchecked, the ceiling height and finish material within the window is the same as that for the adjacent room.
- Specify the **Height Lowered**, which is measured from the ceiling height of the adjacent room.

Note: If the Height Lowered is 0”, Has Lowered Ceiling will become unchecked when you click OK.

- Specify the **Finish Thickness**, which is the thickness of the ceiling’s finish material.
- Specify the **Structure Thickness**, which is the thickness of the ceiling’s structural layer.

## 5 Floor

Specify the height and structure of the **Floor** within the selected window.

- Check **Has Raised Floor** to enable the settings that follow. When this is unchecked, the floor height and material within the window is the same as that for the adjacent room.
- Specify the **Height Raised**, which is the measured from the floor height of the adjacent room.

Note: If the Height Raised is 0”, Has Raised Floor will become unchecked when you click OK.

- Check **Use Floor Finish** to measure the Height Raised distance from the surface of the floor finish. When unchecked, as it is by default, this height is measured from the subfloor.
- Specify the **Finish Thickness**, which is the thickness of the floor’s finish material.
- Specify the **Structure Thickness**, which is the thickness of the floor’s structural layer.

## OPTIONS PANEL

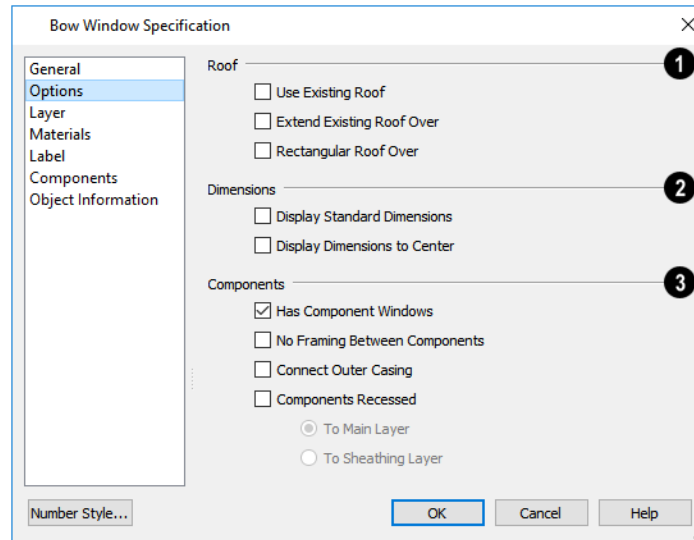

### 1 Roof

Specify the structure of the automatic roof over the selected window unit. See *Bay, Box, Bow Windows and Roofs* on page 610.

- Check **Use Existing Roof** if the existing roof needs no changes to accommodate the bay window.
- Check **Extend Existing Roof Over** to extend the existing roof plane to cover the bay window below.
- Check **Rectangular Roof Over** to create a roof over the bay window that is square across the end instead of following the profile of the roof.

### 2 Dimensions

Specify the appearance of the selected window unit's dimensions in plan view. These dimensions are drawn on the "Dimensions" layer but cannot be selected. See *Dimensions* on page 448.

- Check **Display Standard Dimension** to display the automatically-produced dimensions that show the window's width and depth.
- Check **Display Dimensions to Center** to display a Bow Window's radial dimension.

### 3 Components

Specify the structure of the selected window unit's components and the wall sections containing them.

- Uncheck **Has Component Windows** to remove the component windows of the selected Bay, Box, or Bow Window and disable the settings that follow.
- Check **No Trimmers for Components** to eliminate the trimmer studs for Bay and Box Window components, allowing the width of each component window to increase. See *Wall Framing* on page 852.
- Check **No Framing Between Components** to remove both studs between the component windows.

Note: If the selected unit is moved or resized, its components automatically resize to use a standard trimmer, regardless of whether either of the two options above are selected.

- Check **Connect Outer Casing** to have exterior casing surround the component windows of a Bow Window as a group rather than individually. Mullions are provided between components. This is how interior casing is always created.
- Check **Components Recessed** to recess the component windows into the wall and enable the settings that follow. Typically used if the window is placed in a brick wall and you want to produce a brick molding.
- Select **To Main Layer** to recess the components to the wall's Main Layer instead of the exterior wall surface. See *The Main Layer on page 385*.
- Select **To Sheathing Layer** to recess the components to the sheathing layer instead of the exterior wall surface.

## LAYER PANEL

For information about using the LAYER panel, see *Layer Panel on page 186*.

## MATERIALS PANEL

The settings on the MATERIALS panel are the same as those found on the same panel in dialogs throughout the program. See *Materials Panel on page 1055*.

## LABEL PANEL

Bay, Box, and Bow Window labels display in plan view and cross section/elevation views when the "Windows, Labels" layer is turned on and use the Text Style assigned to that layer. See *Window Labels on page 587*.

For more information about the settings on this panel. See *Label Panel on page 700*.

## COMPONENTS PANEL

The information on the COMPONENTS panel can be used in the materials list. See *Components Panel on page 1330*.

## OBJECT INFORMATION PANEL

The information entered on the OBJECT INFORMATION panel can be used in schedules and the materials list. For more information, see *Object Information Panel on page 1331*.

## SCHEDULE PANEL

The settings on the SCHEDULE panel determine which schedule categories the selected object is included in. See *Schedule Panel on page 704*.



# Cabinets

## Chapter 17

With Chief Architect’s cabinet tools you can create base, wall, and full height cabinets as well as soffits, shelves, partitions, and custom countertops. These objects are very versatile, allowing for a wide range of customization.

A selection of cabinet door and drawer styles are available in the Library Browser and, in addition, a numerous cabinet manufacturer catalogs are available for download on our website, [chiefarchitect.com](http://chiefarchitect.com).

Chief Architect also has many customized cabinets and cabinet groups available in the library. Cabinets you have customized can be saved to your own library for future use.

### TOPICS

<b>Cabinet Defaults</b> .....	<b>618</b>
<b>The Cabinet Tools</b> .....	<b>621</b>
<b>Cabinet Fillers</b> .....	<b>624</b>
<b>Placing Cabinets and Fillers</b> .....	<b>625</b>
<b>Countertops</b> .....	<b>627</b>
<b>Displaying Cabinets</b> .....	<b>628</b>
<b>Cabinet Labels</b> .....	<b>630</b>
<b>Cabinet Construction</b> .....	<b>633</b>
<b>Editing Cabinets</b> .....	<b>634</b>
<b>Editing Cabinet Styles</b> .....	<b>636</b>
<b>Special Cabinets</b> .....	<b>639</b>
<b>Cabinet Specification Dialog</b> .....	<b>643</b>
<b>Cabinet Shelf Specification Dialog</b> .....	<b>658</b>
<b>Hardware Size/Orientation Dialog</b> .....	<b>659</b>
<b>Shelf/Partition Specification Dialog</b> .....	<b>660</b>
<b>Custom Countertop Specification Dialog</b> .....	<b>662</b>

## Cabinet Defaults

There are several defaults dialogs for cabinets. Access Default Settings by selecting **Edit> Default Settings**, then clicking the arrow beside “Cabinets”. Select a subheading and click the **Edit** button to open the defaults dialog associated with your selection.

The Cabinet Defaults dialogs can also be accessed by double-clicking the **Cabinet Tools**  parent button.

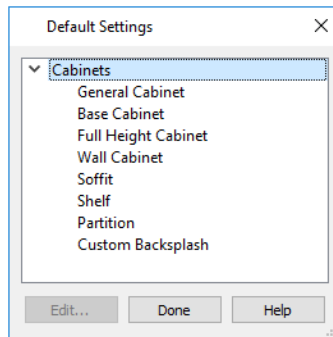

Double-clicking a Cabinet Tools child button also opens its corresponding defaults dialog, if that object has a defaults dialog.

The Base, Wall, and Full Height Cabinet Defaults can be multiple-selected by holding down the Shift or Control keys. See [Shift and Ctrl Select on page 214](#).

Each type of cabinet object has default definitions for size, style, materials and much more. In fact, the default dialog for each cabinet type is similar to its corresponding specification dialog. For descriptions of these settings, see [Cabinet Specification Dialog on page 643](#), [Shelf/Partition Specification Dialog on page 660](#) and [Soffit Specification Dialog on page 1034](#).

Cabinet Fillers and Custom Countertops do not have defaults dialogs. Instead, their initial settings are based on the those of other objects.

- Base Cabinet Fillers’ initial settings are based on Base Cabinet Defaults.
- Wall Cabinet Fillers’ initial settings are based on Wall Cabinet Defaults.
- Full Height Cabinet Fillers’ initial settings are based on Full Height Cabinet Defaults.
- Custom Countertops’ initial settings are based on Base Cabinet Default settings but are also influenced by the settings of cabinets beneath them. See [Countertops on page 627](#).

### DYNAMIC CABINET DEFAULTS

When a dynamic default is changed, existing cabinet objects using the default value are affected. See [Dynamic Defaults on page 79](#).

The following cabinet default values are dynamic: **Separation, Backsplash Height and Thickness, Countertop Overhang and Thickness, Toe Kick Height and Depth, Side and Vertical Overlap, Stiles, and Hardware** spacing.

All **Materials** are also dynamic. In addition, the Cabinet Defaults can be set up to refer dynamically to information in the Material Defaults dialog. This makes it easy to have all cabinet objects in a plan use the same default materials. See [Material Defaults Dialog on page 1051](#).

### ***To use dynamic cabinet Material Defaults***

1. Specify the desired materials for the cabinet categories in the Material Defaults dialog:
  - “Cabinets” can be linked to the default cabinet box, cabinet interior, shelves, and toe kicks as well as to Shelves and Partitions.
  - “Cabinet Door/Drawer” can be linked to the default frames and panels of cabinet doors and drawers.
  - “Countertop” can be linked to the default countertop.
  - “Hardware” can be linked to the default door and drawer pulls and hinges.
2. On the MATERIALS panel of the Base Cabinet Defaults dialog, select the first object component and click the **Select Material** button.
3. The Select Material dialog opens:
  - On the LIBRARY MATERIAL panel, check **Use default material**, or
  - On the PLAN MATERIAL panel, select “Use Default” at the top of the list.
4. Click **OK**, then repeat this step for each of the components in the list.
5. Repeat steps 2-4 in each of the Cabinet Defaults dialogs.

### **SET AS DEFAULT**



You can set the attributes for a cabinet placed in your plan as the defaults for that cabinet type. See *Set as Default on page 79*.

Note: Set as Default is not available for special shaped cabinets. Only Standard cabinets can be the default cabinet type. See *Special Cabinets on page 639*.

### **GENERAL CABINET DEFAULTS**

The General Cabinet Defaults dialog can be accessed only from the Default Settings dialog.

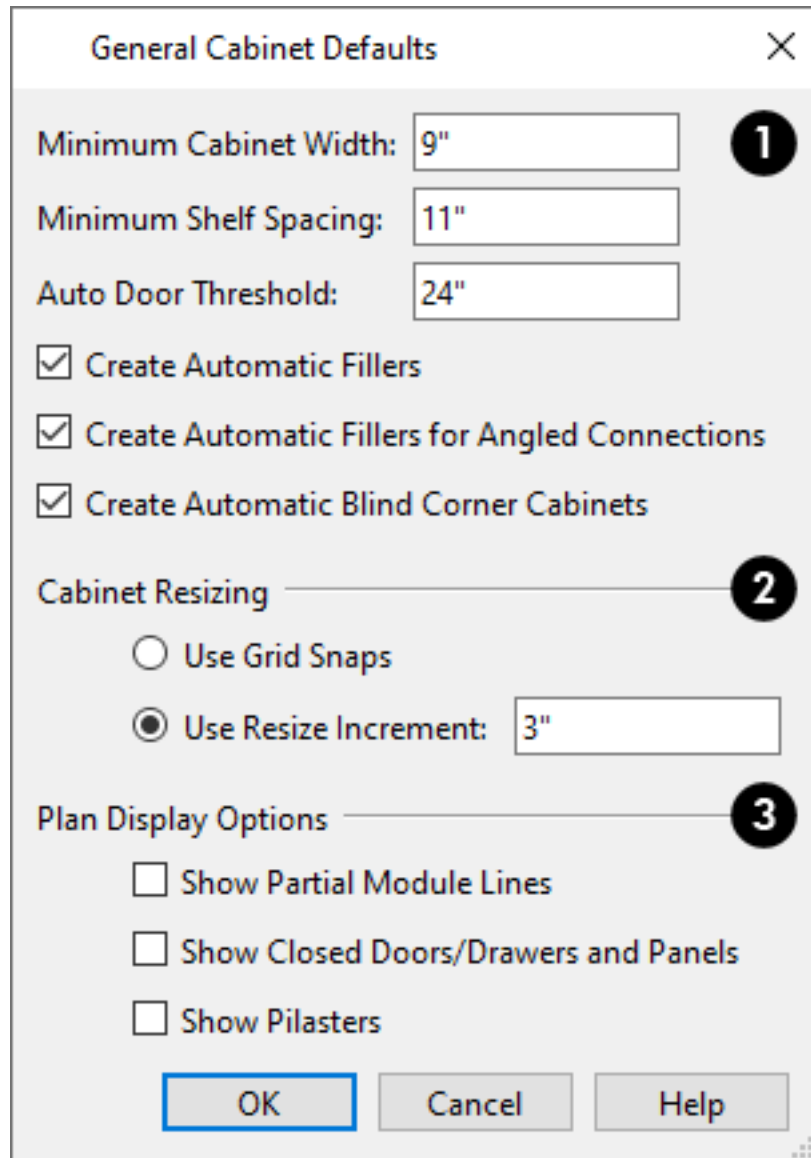

## 1 Automatic Behaviors

- Specify the **Minimum Cabinet Width**. The smallest allowable value is 1/16 of an inch (10 mm).
- Specify the **Minimum Shelf Spacing** inside Door and Opening face items.
- Specify the **Auto Door Threshold**, which controls when Auto Left and Auto Right doors switch from single to double doors. When the opening behind an Auto door is this size or smaller, the Auto door is single; when the opening is larger than this value, a double door is applied. See *Front/Sides/Back Panel on page 648*.
- Uncheck **Create Automatic Fillers** to prevent fillers from automatically generating in spaces between cabinets. This setting is dynamic: changing it will affect cabinets already present in your plan. See *Cabinet Fillers on page 624*.
- Uncheck **Create Automatic Fillers for Angled Connections** to prevent fillers from automatically generating in spaces between cabinets that meet at only one corner. See *Special Cabinets on page 639*.
- Uncheck **Create Automatic Blind Corner Cabinets** to prevent blind corner cabinets from being created. This setting is dynamic: changing it will affect cabinets already present in your plan. See *Blind Cabinets on page 642*.

## 2 Cabinet Resizing

Specify how **Cabinet Resizing** takes place when the edit handles are used.

- Select **Use Grid Snaps** to resize cabinets using Snap Grid increments. See *Grid Snaps on page 163*.
- Select **Use Resize Increment** to resize cabinets using the increment specified here.
- Set the **Resize Increment** at which cabinets resize. The minimum allowable increment is 1/16 of an inch (10 mm).

## 3 Plan Display Options

- Check **Show Partial Module Lines** to represent module lines as grey lines that do not extend across the cabinets. When this is unchecked, lines between merged cabinet modules display as specified by the “Cabinets, Module Lines” layer. See *Displaying Cabinets on page 628*.
- Check **Show Closed Doors/Drawers and Panels** to display closed cabinet doors, drawers, and panels in plan view. When unchecked, these items are not shown. See *Displaying Cabinets on page 628*.
- Check **Show Pilasters** to display corner and front pilasters in plan view. See *Pilasters, Feet, and Moldings on page 638*.

---

# The Cabinet Tools



Select **Build> Cabinet** to access the Cabinet Tools.

Cabinets are easily created with a single click in plan view or any camera view. See *Click-to-Create on page 164*.

Typically, groups of cabinet objects are positioned closely together and arranged to form work spaces, and there are some special behaviors and techniques to be aware of. See *Placing Cabinets and Fillers on page 625*.

Once created, cabinets, soffits, shelves, partitions and fillers can be selected and edited much like other box-based objects. See *Editing Cabinets on page 634*.

## BASE CABINETS



Base cabinets can be placed directly under wall cabinets and generate a countertop and toe kick by default.

## WALL CABINETS



Wall cabinets can be placed directly over base cabinets.

## FULL HEIGHT CABINETS



Full height cabinets generate a toe kick by default and cannot be placed on top of other cabinets.

## BASE, WALL, AND FULL HEIGHT FILLERS



The Base, Wall, and Full Height Filler tools place fillers that look and behave similarly to their corresponding cabinet tools. See *Cabinet Filler Tools on page 624*.

## SOFFITS

 Soffits typically fill the space between cabinet tops and the ceiling, but can also be used to create any object that can be modeled as a 3D box. To place a soffit, select **Build> Cabinet> Soffit** and click in any view.

By default, soffits use the material assigned to interior walls in the Material Defaults dialog. Like cabinets, soffits can have molding profiles applied to them.

For more information about using soffits for a variety of purposes, see *Other Objects on page 1014*.

## SHELVES

 Select **Build> Cabinet> Shelf** and click in any view to create a shelf.

Create corner shelves by placing one shelf on each wall, then moving or stretching them until they touch.

Once created, shelves can be selected and edited. See *Shelf/Partition Specification Dialog on page 660*.

You can also specify shelves inside base, wall, and full height cabinet boxes. See *Cabinet Shelf Specification Dialog on page 658*.

## PARTITIONS

 Select **Build> Cabinet> Partition** button and click in any view to create a vertical partition.

Like shelves, partitions can be selected and edited after they are placed.

Partitions can be used with shelves to create complex storage systems.

## CUSTOM COUNTERTOPS

 Custom Countertops are drawn and edited just like other closed-polyline based objects. Select **Build> Cabinet> Custom Countertop**, then either click and drag a rectangle or single-click to place a 2'x2' countertop. See *Countertops on page 627*.

You can also generate a custom countertop over one or more base cabinets using the **Generate Custom Countertop**  edit tool. See *Using the Edit Tools on page 635*.

## CUSTOM COUNTER HOLES

 Select **Build> Cabinet> Custom Counter Hole**, then either click and drag a rectangle or single-click to place a 2'x2' countertop hole. Custom Counter Holes must be drawn within an existing Custom Countertop, can be drawn in any view except cross section/elevation views and can be edited to any shape. See *Editing Custom Countertops on page 627*.

## CUSTOM BACKSPASHES

 Select **Build> Cabinet> Custom Backsplash** while an elevation or camera view is active, then either click and drag a rectangle or single-click on a wall surface to place a Custom Backsplash Layered Material Polyline on that wall. See *Custom Backsplashes on page 1037*.

A custom backsplash can also be created using the **Convert Polyline**  edit tool. See *Convert Polyline on page 262*.

## CABINET LIBRARY CATALOGS

 In the Library Browser, browse to Chief Architect Core Catalogs> Architectural> Cabinets to access a selection of specialty cabinets. Select the library object you want, then click in any view to place it in the plan. Once placed, library cabinets can be edited. See *Placing Library Objects on page 972*.

A selection of cabinet manufacturer catalogs is also available for download. These catalogs include door and drawer styles and may also provide moldings and millwork, finishes, and hardware. See *Manufacturer Catalogs on page 961*.

In addition, you can add single cabinets and blocked units to the library. See *Adding Library Content on page 965* and *Architectural Blocks on page 1007*.

## CABINET DOORS, DRAWERS, AND PANELS CATALOGS

 A selection of cabinet door panels, drawer fronts, and specialty cabinet storage options can be found in the Library Browser in Chief Architect Core Catalogs> Architectural> Cabinet Doors, Drawers, and Panels.

- Doors, drawers, and panels can be assigned to a cabinet in its specification dialog. See *Door/Drawer Panel on page 652* and *Accessories Panel on page 655*.
- Select a door or drawer in the library, then click on a cabinet in your plan to place the door or drawer onto that cabinet. Side and back panels cannot be applied to cabinets using this approach. See *Inserted Objects on page 973*.
- Cabinet doors and drawers can also be placed as stand-alone fixtures. Once placed, they can be edited like other stand-alone library objects. See *Editing Library Objects on page 970*.

You can create custom cabinet doors and drawers and save them in the library for future use. See *Convert to Symbol on page 1002*.

## BUILT-IN SINKS AND APPLIANCES

A variety of fixtures and appliances such as sinks, cooktops, and dishwashers can be placed into cabinets. See *Inserted Objects on page 973*.

 Place fixtures and appliances into cabinets early, so that any resizing can be done while there is adequate free space.



To insert a fixture into a cabinet, select the fixture in the Library Browser, then click on a cabinet. There must be enough space in the cabinet or adjoining cabinets to contain the selected fixture. Only one front mounted appliance can be inserted in this manner; however, additional front fixtures can be added in the Cabinet Specification dialog. See *Front/Sides/Back Panel on page 648*.

If a sink or cooktop is inserted into a cabinet with a top Drawer or Double Drawer, its Item Type will automatically change to a False Drawer or False Double Drawer.

Once placed, an inserted fixture can be selected and edited:

- To select a fixture in a cabinet top, click on it and then click the **Select Next Object**  edit button. See *Select Next Object on page 211*.
- Front fixtures can only be modified or deleted in the Cabinet Specification dialog. See *Front/Sides/Back Panel on page 648*.

When a cabinet has a fixture on either its top or front, the **Open Symbol**  edit button opens its specification dialog.

When a cabinet has both, the **Open Symbol**  button opens the specification dialog for the fixture on the front. When a cabinet has multiple front appliances, the **Open Symbol**  edit button will not be available.

 Fixtures can be added to both the top and front of the same cabinet. It is up to you to determine which can be effectively and safely combined in the real world.

## STORAGE AND ORGANIZATION INSERTS

Rollout organizing and storage items can be specified for any Door or Opening front item in the Cabinet Shelf Specification dialog. See *Rollout Shelves and Storage on page 629*.

Inserts for drawers and the backs of doors can be specified in the Door and Drawer Face Item Specification dialogs. See *Door/Drawer Panel on page 652*.

## ELECTRICAL SWITCHES AND OUTLETS



Electrical switches and outlets can be placed on cabinets in most views. See *The Electrical Tools on page 668*.

---

# Cabinet Fillers

Cabinet fillers can be created automatically, placed manually, or specified as part of a cabinet's face frame.

All three types of fillers are included in the Materials List and are rounded to the nearest 1/16" (1 mm). Automatic and manually placed fillers are listed as individual items, while extended stiles are listed as components of their cabinets. Manually placed **Cabinet Fillers** can be listed in Cabinet Schedules, as can information about any cabinets' extended stiles. Auto fillers, however, are not listed. See *Cabinet Schedules on page 630*.

## AUTOMATIC FILLERS

By default, Chief Architect automatically generates fillers when cabinets of the same height are either touching or placed with 3" (75 mm) of one another. Automatic fillers receive the same toe kick, moldings, and backsplash as adjacent cabinets, and model a continuous countertop.

If two cabinets meeting at a corner are separated from each other by 3" (75 mm) or less, the program will automatically generate a filler in the angle between them. A filler is used to separate the front of one of these cabinets from the one it meets so that drawers and doors have room to operate.

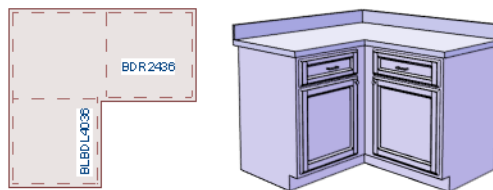

You can specify whether these automatic fillers generate in both situations the General Cabinet Defaults dialog. See *General Cabinet Defaults on page 619*.

## CABINET FILLER TOOLS

If you prefer, you can place cabinet fillers manually using **Cabinet Fillers**. Select **Build> Cabinet**, choose the desired tool from the submenu, then click to place a filler just as you would a cabinet, in any view.





**Base Cabinet Fillers** are composed of a front surface, a toe kick and a section of countertop.



**Wall Cabinet Fillers** are composed of a front surface only.



**Full Height Cabinet Fillers** are composed of a front surface and a toe kick.

By default, fillers are 3" (75 mm) wide with a single Blank face item, and inherit their other attributes from the defaults for their associated cabinet type. See [Cabinet Defaults on page 618](#).

You can convert a regular base, wall or full height cabinet into a filler by checking **Filler** in the Cabinet Specification dialog. Similarly, a cabinet filler can be converted to a regular cabinet by unchecking this box. See [General Panel on page 644](#).

Once created, manually placed cabinet fillers can be edited much like regular cabinets. See [Editing Cabinets on page 634](#).

## EXTENDED FACE FRAMES

You can also produce fillers by extending the front face on either side of a Framed cabinet. These extended stiles take precedence over the automatic fillers, but otherwise behave much like them. They affect the generation of toe kicks, moldings, backsplashes, and countertops but do not extend into adjacent walls or cabinets. See [Box Construction Panel on page 647](#).

In plan view, extended stiles on cabinets are represented using lines on the cabinet's primary layer. In cabinet labels, they are indicated using "XL", "XR", and "XLR". See [In Plan View on page 628](#) and [Cabinet Labels on page 630](#).

---

# Placing Cabinets and Fillers

Cabinets and cabinet fillers are easily created with a single click in any view. See [Click-to-Create on page 164](#).

When used near a wall corner, the Cabinet Tools will produce corner cabinets and soffits. See [Corner Cabinets on page 639](#).

When created, cabinets are positioned relative to the floor of the room in which they are placed. Base and full height cabinets typically rest on the floor while wall cabinets are placed a set distance above the floor. See [Cabinet Defaults on page 618](#).

If the ceiling height of the room does not accommodate the height of a cabinet, its **Floor to Bottom** value will be retained and its **Height** will be reduced so that it fits under the ceiling. When this happens, some front items may be removed from the cabinet if there is not enough room for them. See [Front/Sides/Back Panel on page 648](#).

Because cabinets are typically organized into groups with shared attributes, they have some special behaviors.

## CABINET SNAPPING AND ALIGNING

Cabinets have several special snapping and aligning behaviors which help you create precisely aligned cabinets quickly and easily.

- When Base and/or Full Height cabinets are within 3" of one another's sides, they will snap together. Wall cabinets snap in a similar manner, but only with other Wall cabinets.
- When Base and/or Full Height cabinets are within 3" of one another's sides and their front or back surfaces are within 3" of aligning, they will become aligned. Wall cabinets snap in a similar manner with other Wall cabinets as well as Full Height cabinets.

- When a Base and/or Full Height cabinet is placed against the back of another Base or Full Height cabinet, its back surface will automatically face the other cabinet's back. Wall cabinets snap in a similar manner with other Wall as well as Full Height cabinets.
- When a cabinet or cabinet filler is placed against a wall, its back and/or side will snap to the wall and, if the wall is moved, the cabinet will move with it.

When cabinets are snapped to a wall or to other cabinets, only exposed end cabinets have side counter overhangs, closed toe kicks, feet and corner pilasters. Adjacent cabinet fronts share front pilasters.

Cabinet snapping and aligning occurs even when **Object Snaps**  are turned off; however, you can override this behavior by moving a cabinet into the desired position using dimensions. See *Moving Objects Using Dimensions on page 483*.

## CABINET MERGING

When cabinets of the same height and type are placed side-by-side within 3" (30 mm) of one another they will automatically merge, making any shared components such as the toe kick, countertop, backsplash, and moldings continuous. Any gap between merged cabinets will be automatically filled.

The exposed ends of merged cabinets have side counter overhangs, closed toe kicks, feet and corner pilasters. Adjacent merged cabinets share front pilasters.

Cabinets placed at different angles will also merge if they face toward one another and meet at a front corner. Cabinets that meet at a back corner will also merge provided that they face away from one another at an angle no greater than 87°. In either case, a filler is created in the angle between the two.

If the side of a cabinet is placed within 3" (30 mm) of a wall, the countertop will extend to the wall and a filler will be created.

Cabinet merging occurs even when **Object Snaps**  are turned off; however, you can suppress this behavior for cabinets that do not actually touch by turning off **Create Automatic Fillers**. See *General Cabinet Defaults on page 619*.

## BASE AND WALL CABINETS

Base and wall cabinets have different default heights, so they can be placed directly above or below one another without interference. You can use **Object Snaps**  to center a wall cabinet's back center point above that of a base cabinet, or vice versa. See *Click-to-Create on page 164*.

## MINIMUM CABINET SIZE

If you try to place a cabinet into a space that is too narrow for its default size, the program will place a smaller cabinet with a width that is a multiple of the default **Resize Increment**. For example, if you try to place a 24" wide cabinet in a 20" wide space and your Resize Increment is 3", the program places an 18" cabinet. See *General Cabinet Defaults on page 619*.

If you try to place a cabinet into a space narrower than the default **Minimum Cabinet Width**, a cabinet will not be placed. If, for example, you have a space that is 8" and your Minimum Cabinet Width is 9", no cabinet is placed.

## CABINET FILLERS

By default, the program will automatically place a filler between cabinets that are within 3" of one another. You can instead turn off **Create Automatic Fillers** and place fillers manually.

---

# Countertops

Countertops are automatically generated on top of base cabinets, but can also be drawn manually.

## AUTOMATIC COUNTERTOPS

Base cabinets automatically receive countertops as specified in the Base Cabinet Defaults dialog. These default countertops are components of the cabinets and can be edited in the Cabinet Specification dialog, but cannot be selected and modified separately.

The overhangs on automatic countertops are clipped on any side where the cabinet is positioned against or within 3" (75 mm) of a wall, a Full Height Cabinet, a Partition, or free-standing appliance from the Library. Edge profiles on those sides are also suppressed, as are toe kicks.

## CUSTOM COUNTERTOPS



When an automatic countertop does not meet your needs, you can instead use a **Custom Countertop**. In any view except a cross section/elevation, select **Build > Cabinet > Custom Countertop**, then either click and drag a rectangle or single-click to place a 2'x2' countertop polyline. This countertop can be selected independent of any cabinets beneath it and is edited just like other closed-polyline based objects. See [Editing Closed Polyline-Based Objects on page 228](#).

When a Custom Countertop covers any portion of a base cabinet, it overrides that cabinet's automatic countertop and bases its thickness and height on the base cabinet below.

- If there are multiple cabinets below, it uses the specifications for the cabinet with the greatest overall height.
- If there is no base cabinet below, its height and thickness are based on the base cabinet defaults. See [Cabinet Defaults on page 618](#).

If a sink or built-in appliance is added to the cabinet, a hole for the fixture is automatically cut in the Custom Countertop.

By default, if a side of a Custom Countertop is positioned against a wall, the edge profile on that side will not generate.



You can also generate a Custom Countertop over one or more selected base cabinets by clicking the **Generate Custom Countertop** edit button. See [Using the Edit Tools on page 635](#).

When created in this manner, the Custom Countertop inherits the cabinet's countertop material. If the cabinet has a To Top molding profile at counter height, the Custom Countertop will inherit it, as well. See [Pilasters, Feet, and Moldings on page 638](#).

## EDITING CUSTOM COUNTERTOPS

Once created, a custom countertop or Custom Counter Hole can be selected in 2D and 3D views and edited like other closed-polyline based objects. See [Editing Closed Polyline-Based Objects on page 228](#).

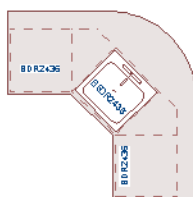

Custom countertops initially use the default countertop material set in the Base Cabinet Defaults dialog. You can specify a different material as well as the height and position in the Custom Countertop Specification dialog. See [Custom Countertop Specification Dialog on page 662](#).

You can also specify the edge profile of a custom countertop in the Custom Countertop Specification dialog. See [Moldings Panel on page 661](#).

## WATERFALL COUNTERTOPS



To add a vertical waterfall to the edge of a Custom Countertop, select that edge and click the **Add Waterfall to Selected Edge** edit button. See [Selected Edge on page 212](#).

You can also specify a waterfall edge as well as edit its attributes in the Custom Countertop Specification dialog. See [General Panel on page 662](#).



To remove a waterfall from a countertop edge, select that edge and click the **Remove Waterfall from Selected Edge** edit tool.

---

## Displaying Cabinets



The display of the various cabinet object types, labels, module lines, door opening indicators, and more is controlled in the Layer Display Options dialog. See [Layer Attributes on page 177](#).

### IN PLAN VIEW

Fill Styles and colors that display in plan view can be assigned to cabinet objects. See [Fill Styles on page 192](#).

Like other objects, cabinets are placed in Drawing Groups that affect whether they display in front of or behind other objects in plan view. By default, wall cabinets, soffits and shelves are drawn in front of base and full height cabinets, countertops and partitions. You can modify a selected cabinet's place in the drawing order by clicking the **View Drawing Group Edit Tools**  edit button. See [Drawing Group Edit Tools on page 190](#).

Objects assigned to cabinets, including hardware and moldings, are located on the same layer as their parent object. They display in 3D views, but are not shown in plan view. There are a few exceptions:

- Both automatic and Custom Countertops are drawn on the "Cabinets, Countertops" layer in all views. In plan view, countertops use the line style, color, and weight assigned to this layer; in 3D views, the line attributes of the parent object's layer is used instead.
- Cabinet doors, drawers, and panels are drawn on the "Cabinets, Doors & Drawers" layer in all views. When closed, however, they only display in 3D views by default. See [Cabinet Doors and Drawers on page 629](#), below.
- End panels are also drawn on the "Cabinets, Doors & Drawers" layer and only display in 3D views by default.
- Closed Doors, Drawers and Panels as well as Pilasters can be set to display in plan view in the General Cabinet Defaults dialog. See [General Cabinet Defaults on page 619](#).
- You can also display cabinet front indicator arrows in plan view by turning on the "Cabinets, Front Indicators" layer.

Both automatic and Custom Countertops can be assigned an edge profile, and can display the width of this profile when **Display Molding Edges in Plan Views** is selected in the Base Cabinet or Custom Countertop Specification dialog. If you wish to display this or any cabinet molding in plan view on its own layer, use the **Make Cabinet Molding Polyline**  edit tool. See [Make Cabinet Molding Polyline on page 638](#).

By default, cabinet module lines display in plan view when cabinet objects of the same type are placed side by side. If you prefer that these lines not display, turn off the “Cabinets, Module Lines” layer. This layer also controls the display of the lines associated with extended face frames. You can also specify whether module lines are full or partial. See [General Cabinet Defaults on page 619](#).

Cabinet labels display in plan and cross section/elevation views when the “Cabinets, Labels” layer is turned on Text Style assigned to their layer. See [Cabinet Labels on page 630](#).

## IN 3D VIEWS





A cabinet’s label will display in cross section/elevation views when the “Cabinets, Labels” layer is turned on and the center point of the cabinet’s front is visible in the view. See [Cabinet Labels on page 630](#).

In 3D Vector Views, cabinet doors can display opening indicator arrows. See [Opening Indicators on page 549](#).

## CABINET DOORS AND DRAWERS

There are several options for controlling the display of cabinet doors and drawers in plan and 3D views.

Cabinet doors and drawers are drawn on the “Cabinets, Doors & Drawers” layer. In plan view, they use the line style, color, and weight assigned to that layer when they are set to display. In 3D Vector Views, they use the line style, color, and weight assigned to their parent cabinet’s layer.

- Cabinet doors and drawers can be drawn open or closed in both plan and 3D views.
- To draw a selected cabinet’s doors open in all views, click the **Open Cabinet Doors**  edit button. Any shelves set as Rollout will display in 3D views as well.
- To draw its drawers open in all views, click the **Open Cabinet Drawers**  edit button.
- To close the doors and/or drawers, click the **Close Cabinet Doors**  or **Close Cabinet Drawers**  edit button.

Cabinet doors and drawers also can be set to **Show Open** in the Cabinet Specification dialog. In addition, you can specify how far open each is drawn. See [Front/Sides/Back Panel on page 648](#).

By default, doors and drawers do not display in plan view when they are closed: even when the “Cabinets, Doors & Drawers” layer is set to display. You can, however, check **Show Closed Doors/Drawers in Plan Views** in the General Cabinet Defaults dialog. See [General Cabinet Defaults on page 619](#).

## ROLLOUT SHELVES AND STORAGE

Shelves can be specified for Door and Opening cabinet front items and are visible in 3D views. Those inside Doors will only display in 3D views when Doors and Rollout Shelves are set to **Show Open**. See [Front/Sides/Back Panel on page 648](#).

Shelves can be specified as **Rollout**, each with its own rollout percentage, and will display in 3D views when Doors and Rollout Shelves are set to **Show Open**. If a Rollout shelf is in a Door item, the door must be set to 100% **Percent Open** in order for the shelf to draw open. See [Cabinet Shelf Specification Dialog on page 658](#).

Cabinet shelves and added storage items do not display in plan view.

## IN THE MATERIALS LIST

The materials associated with cabinet objects are listed under different Categories in the Materials List:

- **Cabinets** - Lists Cabinets, Shelves, Partitions, Custom Countertops, Custom Backsplashes, Cabinet Fillers, storage and organization inserts, as well as cabinet doors and drawers placed from the library as free-standing objects.

- **Interior Trim** - Lists Soffits and any moldings assigned to cabinet objects located in Interior rooms. Note that Soffits are not listed in the Materials List unless a non-default material is applied to them.
- **Exterior Trim** - Lists any Soffits and moldings assigned to cabinet objects located in Exterior rooms. See *Room Types and Functions on page 415*.
- **Fixtures** - Lists any sinks inserted into base cabinets. See *Inserted Objects on page 973*.
- **Appliance** - Lists any appliance fixtures inserted into cabinets. If a base cabinet has an under-counter appliance inserted into it, that cabinet will not be counted in the Materials List - only the countertop and backsplash materials associated with it will be listed. The cabinet will also display the appliance's label information instead of its own. See *Cabinet Labels on page 630*.

As with other objects, there are a number of ways to control how, or whether, cabinets are included in the Materials List. See *Organizing Materials Lists on page 1310*.

You can add and edit information about a cabinet's accessories in the Cabinet Specification dialog. See *Components Panel on page 1330*.

Note that cabinet door and drawer height is described in two different ways:

- In the Cabinet Specification dialog, the Item Height for cabinet doors and drawers describes the height of the opening in the cabinet box rather than that of the door or drawer front. See *Front/Sides/Back Panel on page 648*.
- In the Materials List, the full height of cabinet door and drawer front is listed in the Size column.

## CABINET SCHEDULES

 The **Cabinet Schedule** tool is set up to produce customizable cabinet schedules as well as cabinet labels that display schedule numbers. Cabinet objects can, however, be included in any schedule. See *Schedules and Object Labels on page 681*.

In addition to cabinets, Soffits, Shelves, Partitions, free-standing cabinet panels, Countertops, Custom Backsplashes, and holes in Custom Countertops and Custom Backsplashes can also be listed in schedules. Manually-placed Cabinet Fillers can be listed, as well; however, automatically-generated fillers cannot. See *Cabinet Fillers on page 624*.

Cabinet moldings and counter profiles can be included in schedules, as well. They are found in the "Molding" category, and have several molding-specific Columns, including "Total Length". If you specify a Type for a cabinet molding, it will be reported in the Description column. See *Cabinet Moldings and Counter Profiles on page 930*.

Individual cabinets in Architectural Blocks are also included in cabinet schedules provided that they are set to be included and **Treat as One Object** is unchecked in the Architectural Block Specification dialog. See *General Panel on page 1011*.

By default, some cabinets with built-in appliances will not be included in a schedule. Examples include base cabinets with dishwashers or built-in ranges. You can, however, specify that the cabinet be included in one or more schedule categories if you wish. See *Schedule Panel on page 704*.

---

## Cabinet Labels

Labels for cabinets and cabinet fillers display in plan and cross section/elevation views when the "Cabinets, Labels" layer is turned on. See *Label Panel on page 700*.

Shelves and Partitions can also display labels when the "Cabinets, Labels" layer is turned on, while Custom Countertop labels display when the "Polylines 3D, Labels" layer is turned on. Unlike cabinets and cabinet fillers, the Automatic Label for these objects is blank; however, you can specify a custom label in their specification dialogs.

Cabinet labels have their own edit handles and can be moved and rotated when a cabinet is selected. They use the Text Style specified for the "Cabinets, Labels" layer. See *Text Styles on page 538*.

If a base cabinet’s only front item aside from Separations and Blank Areas is an Appliance, the appliance’s label will display instead of the cabinet’s, and will be placed on the “Cabinets, Labels” layer.

Cabinet labels are available in three different formats:

- **Automatic Labels**, which include size, type and other information in abbreviated form.
- **User-Specified**, which are entered in the Cabinet Specification dialog. See *Label Panel on page 700*.
- **Schedule Callout Labels**, which are specified in the Cabinet Schedule Specification dialog. See *Labels Panel on page 697*.

The minimum on-screen display size of object labels can be specified in the Preferences dialog. See *Appearance Panel on page 95*.

### AUTOMATIC LABELS

The format for automatic cabinet labels has four parts: Key, Code, Size, and Door Swing.

The **Key** provides basic information about the cabinet box and its use. B refers to base cabinets, W refers to wall cabinets and U refers to full height cabinets.

Together with the key, the **Code** provides additional information about the shape of the cabinet box:

Code	
	<b>All Cabinets</b>
<b>LS + Key</b>	Lazy Susan
<b>LSD + Key</b>	Lazy Susan Diagonal Door
<b>DC + Key</b>	Diagonal Door
<b>LC + Key</b>	Left Corner
<b>BC + Key</b>	Blind Corner
<b>PBC + Key</b>	Peninsula Blind Corner
<b>Key + P</b>	Peninsula
<b>Key + F</b>	Filler
<b>E + Key</b>	Right or Left End
<b>A + Key</b>	Angled Front
<b>PR + Key</b>	Peninsula Radius
<b>R + Key</b>	Radius End
<b>Key + XL</b>	Extend Left Face Frame
<b>Key + XR</b>	Extend Right Face Frame
<b>Key + XLR</b>	Extend Left and Right Face Frame
<b>B</b>	<b>Base</b>
<b>OB</b>	Oven Base
<b>SB</b>	Sink Base
<b>RB</b>	Range Base
<b>#DB</b>	Drawer Bank (# is the number of drawers)

Code	
<b>FHB</b>	Full Height Base (1 full height door)
<b>W</b>	<b>Wall</b>
<b>Code above + #D</b>	Drawer (# is the number of drawers)
<b>U</b>	<b>Full Height (Utility)</b>
<b>OTC</b>	Tall Oven
<b>RTC</b>	Tall Refrigerator

Blind corner cabinets are dependent on the cabinet’s position in the plan. A cabinet can only be a blind corner cabinet when its front is partially hidden by another cabinet. See *Blind Cabinets on page 642*. If a cabinet is moved, therefore, its Code information may change.

Peninsula cabinets are only designated as such when they have one or more doors on the back side. See *Front/Sides/Back Panel on page 648*.

The **Size** follows the Code in a cabinet label. Cabinet width is always included in the label; depth and height, on the other hand, may be included depending on the cabinet type and whether they are standard or non-standard.

Base and full height cabinet labels present Size information in this order: width, depth, height. Wall cabinet labels present it in a slightly different order: width, height, depth.

	Sizes
<b>Base</b>	<b>W(D)(H)</b>
<b>Width (W)</b>	Always included
<b>Depth (D)</b>	24” (60 cm)
<b>Height (H)</b>	34 1/2” (90 cm)
<b>Corner Depth (D)</b>	Depth = Width
<b>Wall</b>	<b>WH(D)</b>
<b>Width (W)</b>	Always included
<b>Depth (D)</b>	Always included
<b>Height (H)</b>	12” (30 cm)
<b>Corner Depth (D)</b>	Depth = Width
<b>Full Height</b>	<b>WDH</b>
<b>Width (W)</b>	Always included
<b>Depth (D)</b>	Always included
<b>Height (H)</b>	Always included
<b>Corner Depth (D)</b>	Always included

**Door Swing** is included at the end of the label as either **L** or **R**, but only if all the doors on a cabinet have the same swing.

Here are a few examples of automatic cabinet labels and their meanings:

- **3DB24**: Base cabinet with 3 drawers, 24” wide. Depth and height are standard.
- **SB24R**: Sink base, 24” wide, with a right door. Depth and height are standard.
- **BCW2436R**: Blind wall cabinet, 24” wide, 36” high, with a right door. Depth is standard.



- **DCW2436L:** Diagonal corner wall cabinet, 24” wide, 36” high, with a left door. Depth is standard (equal to width).
- **OTC362490:** Full height cabinet with oven, 36” wide, 24” deep, 90” high.

 The Automatic Labels for Shelves and Partitions are blank, but you can specify custom labels for both. See [Shelf/Partition Specification Dialog on page 660](#).

---

## Cabinet Construction

Both framed and frameless, or European-style, cabinet construction can be specified in Chief Architect. You can also specify either the overlay or reveal of cabinet doors, drawers, and panels.

If you know what cabinet construction style you want, you can save time by specifying that style in the Cabinet Defaults dialogs before you start placing cabinets. See [Cabinet Defaults on page 618](#).

A wide variety of cabinet attributes, including construction, can be included in and applied to multiple cabinets and cabinet fillers at once using **Style Palettes**. See [Style Palettes on page 279](#).

### FRAMED AND FRAMELESS

A cabinet can be specified as Framed or Frameless on the BOX CONSTRUCTION panel of the Cabinet Specification dialog. See [Box Construction Panel on page 647](#).

The sides of both Framed and Frameless cabinet boxes are 3/4" (18 mm) thick. This value is also the system default Item Height for Separation face items in Frameless cabinets. See [Cabinet Defaults on page 618](#).

Framed cabinets have left and right stiles with widths that can be specified. The stiles on the Front face of a cabinet can also be set to Extend past its sides. The Separation value set on the BOX CONSTRUCTION panel of the Cabinet Specification dialog serves as the default Height value for separation face items as well as the default width for left and right stiles. These can be set individually on the FRONT/SIDES/BACK panel. See [Front/Sides/Back Panel on page 648](#).

### TRADITIONAL OVERLAY

To specify how far doors, drawers and panels overlap vertical stiles and horizontal separations, select **Traditional Overlay** on the BOX CONSTRUCTION panel of the Cabinet Specification dialog and then specify the **Overlap** of all doors, drawers, and panels on the selected cabinet.

When Traditional Overlay is selected, the widths of stiles can be specified on the FRONT/SIDES/BACK panel, as can the heights of selected Separation items; however, the overlap of individual items cannot.

### FULL OVERLAY AND REVEAL

To specify the reveal on horizontal separations and vertical stiles, select **Full Overlay** on the BOX CONSTRUCTION panel and then specify the desired **Reveal**. Both the sizes and the reveals on the Left and Right Stiles and on individual Separation items can be customized on the FRONT/SIDES/BACK panel.

### INSET DOORS AND DRAWERS

Cabinet doors and drawers can be specified as Inset instead of overlaid on the BOX CONSTRUCTION panel of the Cabinet Specification dialog.

## Editing Cabinets

Cabinets and cabinet fillers can be selected in 2D and 3D views both individually and in groups and edited using the edit handles, the Edit Toolbar and their specification dialog.

 You can marquee-select cabinets of multiple types when the Full Height Cabinet tool is active. See [Marquee Select on page 213](#).

### USING THE EDIT HANDLES

Cabinets can be edited like other box-based objects. See [Editing Box-Based Objects on page 232](#). The edit handles that a cabinet displays when selected will vary depending on the view.

When a cabinet is selected in plan view or on its top surface in a 3D view, ten edit handles display: the Move handle at the center, the Rotate handle, and a Resize handle on each edge and at each corner. In plan view, cabinet labels also have a small square Move edit handle and small rectangular Rotate handle. See [Displaying Cabinets on page 628](#).

In 3D views, cabinets can be selected on any surface: front, side, back or top. When the side of a cabinet is selected, five edit handles are available: the Move handle and a Resize handle on each edge.



In cross section/elevation views, a cabinet label will also display on a cabinet's front when that side is visible and their label is set to display, and will have the same edit handles as in plan view.

Cabinets cannot be concentrically resized, even when the Concentric edit behavior is enabled. See [Defaults, Preferences, and Edit Behaviors on page 206](#).

### IN THE SPECIFICATION DIALOG

 A selected cabinet can be customized in a variety of ways in its specification dialog. See [Cabinet Specification Dialog on page 643](#).

When you group select cabinets of different types, some options are not available in the Cabinet Specification dialog. For example, you cannot modify the crown molding on a full height cabinet if it is selected with a base cabinet that does not have crown molding. Any specifications that they share in common, however, can be edited.

Soffits, shelves, and partitions can also be group-selected and edited using a shared specification dialog. It is, however, necessary that only soffits, or only shelves, or only partitions be a part of the selection set in order to access a shared specification dialog.

You can use the **Object Painter**  tools to assign the properties of one cabinet to other cabinets. See [Matching Properties on page 282](#).

You can also apply a variety of cabinet attributes to multiple cabinets and cabinet fillers at once using **Style Palettes**. See [Style Palettes on page 279](#).



## EDITING BUILT-IN SINKS AND APPLIANCES

The Library Browser features a selection of fixtures that can be inserted into cabinet fronts and countertops. Once placed, these fixtures can be edited via the Cabinet Specification dialogs:

- Top-mounted fixtures can be edited on the [Accessories Panel on page 655](#).
- Cabinet front fixtures can be edited on the [Front/Sides/Back Panel on page 648](#).

In addition, top-mounted fixtures can be selected and edited in plan and 3D views using the **Select Next Object**  edit tool. See [Select Next Object on page 211](#).

When cabinet with a top-mounted fixture is selected:

- The **Open Object**  edit button opens the Cabinet Specification dialog. See [Cabinet Specification Dialog on page 643](#).
- The **Open Symbol**  edit button opens the Symbol Specification dialog. See [Symbol Object Specification Dialogs on page 986](#).

## USING THE EDIT TOOLS

A cabinet or cabinets can be edited in a variety of ways using the buttons on the Edit Toolbar. See [The Edit Toolbar on page 130](#).



The **Open Cabinet Doors/Drawers** and **Close Cabinet Doors/Drawers** tools affect the cabinet's doors and drawers in 2D and 3D views. See [Cabinet Doors and Drawers on page 629](#).



**Generate Custom Countertop** replaces a base cabinet's countertop with a separate Custom Countertop object. See [Custom Countertops on page 627](#).



**Make Cabinet Molding Polyline** creates a Molding Polyline that replaces a molding applied directly to a selected cabinet. See [Make Cabinet Molding Polyline on page 638](#).



**Select Next Object** allows you to select a fixture inserted into a cabinet. See [Select Next Object on page 211](#).



**Open Symbol** allows you to edit an inserted fixture's symbol data. See [Symbol Object Specification Dialogs on page 986](#).

## ADD TO LIBRARY



Cabinets can be saved in the Library Browser. Select a base, wall or full height cabinet or cabinet filler and click either the **Add to Library** or **Add to Library As** edit button. See [Add to Library on page 965](#).

If you use **Add to Library As** , you can add the selected cabinet to the library in either of two ways:

- Select Cabinet Module to save the cabinet along with its doors, drawers and panels and any fixtures or appliances.
- Select Cabinet Doors and Drawers to save the cabinet door style only.

## USING DIMENSIONS



Like various other objects, cabinets can be moved and resized using dimensions. See [Moving Objects Using Dimensions on page 483](#).

In order to be edited using dimensions, cabinets must be located by them. In the Dimension Defaults dialog, you specify what components of a cabinet are located by dimensions as they are drawn:

- Cabinet sides, corners, and centers can be located in both plan and elevation views.
- Closed cabinet doors, drawers, and panels can be located in plan view provided that they are set to display. See *Dimension Defaults Dialog on page 451*.
- Cabinet face items, openings, backsplash heights, countertop heights, toe kick heights, and molding heights can be located in elevation views. The heights of cabinet components cannot, however, be edited using dimensions.
- Automatic and Custom Countertops can be located as well as edited in both plan and elevation views provided that Countertops are set to be located.
- If **Display Molding Edges in Plan View** is checked in the Base Cabinet Specification dialog, a cabinet's counter edge profile will display and can be located by dimensions provided that Cabinet Moldings are set to be located.
- Automatic Backsplashes can also be located and edited in both types of views provided that CAD Objects are set to be located.

See *Locate Manual Panel on page 454*.

If you wish, you can add or move a dimension's extension lines to locate countertop edges in plan view after the dimension line is drawn. In elevation views, the heights of cabinet face items, openings, the toe kick, backsplash, and/or moldings can also be located in this manner.

Depending on whether a cabinet box or Custom Countertop is selected, Temporary Dimensions will locate objects near the Selected Edge somewhat differently: See *Temporary Dimensions on page 473*.

- If a cabinet box is selected, Temporary Dimensions will locate the nearest wall surface or another cabinet box, but not automatically generated or Custom Countertops.
- If a Custom Countertop is selected, Temporary Dimensions will locate the nearest wall surface, Custom Countertop, or automatically generated countertop edge.

## MOVING WALLS WITH CABINETS ATTACHED

When a cabinet is placed or moved against a wall, it will snap to the wall and become attached to it. When a wall is moved, all attached cabinets move with it.

When wall layers are resized or the wall layer definition redefined, the cabinets may become unattached. To reattach, select the cabinets, drag them away from the wall, and then drag them back again.

---

## Editing Cabinet Styles

A variety of settings allow you to customize the appearance of your cabinets to create styles ranging from traditional to contemporary.

If the desired style is known before cabinets are placed, you can save time by specifying that style in the Cabinet Defaults dialogs before you start drawing. See *Cabinet Defaults on page 618*.

A wide variety of cabinet style attributes can be included in and applied to multiple cabinets and cabinet fillers at once using **Style Palettes**. See *Style Palettes on page 279*.

 A variety of cabinet style attributes, including doors and drawers, moldings, and millwork accessories can be replaced with different items selected in the library. See [Replace From Library on page 976](#).

## CABINET FACE ITEMS

A variety of different face items can be added to the front of any cabinet, including doors, drawers, cutting boards, and horizontal separations. Face items can be moved, resized, as well as removed and can also be split vertically or horizontally to produce a variety of custom configurations. See [Front/Sides/Back Panel on page 648](#).

When adding, removing, or resizing face items, it is helpful to keep a few rules in mind:

- Door and drawer Item Height settings reflect the height of the opening rather than that of the front item. When **Traditional Overlay** is specified, an item's front height will be equal to its **Item Height** plus its top and bottom **Vertical Overlap**.
- When the overall height of a cabinet or the height of a face item is changed, the height of the lowest face item that is not a Separation is adjusted to accommodate the change.
- If you increase the height of the lowest face item, the non-Separation item directly above is adjusted; if you decrease its height, a Blank Area and Separation are created below it.
- If the bottom-most face item on a cabinet is a Separation and you increase its height to be greater than the default value, it will extend down past the bottom of the cabinet, creating a recessed bottom.
- By default, if the bottom-most face item on a cabinet is anything other than a Separation or Blank Area, the cabinet box will be treated as an appliance garage and will not have a bottom.

Note: To ensure that Face Item heights always equal the total cabinet front height, the program automatically adjusts the bottom Face Item as changes are made elsewhere. This means you should start editing Face Items at the top and work down.

When editing a cabinet's width, or when adding or removing features that affect the width of a cabinet's front items, the program will try to maintain the relative sizes of face items in any vertically split layouts.

## DOORS, DRAWERS AND PANELS

- Cabinet doors, drawers, and panels can be applied in either of two ways:
  - In the Cabinet Specification dialog. See [Door/Drawer Panel on page 652](#) and [Front/Sides/Back Panel on page 648](#).
  - Directly from the Library Browser.

Select a style in the Library, then click on a cabinet to apply the selected style to that cabinet. See [Replace From Library on page 976](#).

A secondary door or drawer style can also be specified - for example, to create glass doors above solid doors in wall cabinets. See [Front/Sides/Back Panel on page 648](#).

## FRAMED AND FRAMELESS CABINETS

Both framed and European-style frameless cabinets can be specified in Chief Architect.

For both types of cabinet, you can define the door and drawer overlay or specify inset doors. On a traditional framed cabinet, you can also control the size of the rails and stiles. See [Front/Sides/Back Panel on page 648](#).

## CABINET HARDWARE

Cabinet handles, pulls, and hinges can be assigned in the Cabinet Specification dialog. See *Door/Drawer Panel on page 652*.

The hardware on individual doors and drawers can also be customized. See *Front/Sides/Back Panel on page 648*.

In 3D views, cabinet hardware can also be applied directly from the Library Browser. Select a cabinet hardware item in the Library, then click on a cabinet door or drawer to assign it to all face items of that type, including custom hardware on individual face items. See *Inserted Objects on page 973*.

## PILASTERS, FEET, AND MOLDINGS

Pilasters can be applied to any cabinet in its Cabinet Specification dialog. Cabinet feet can also be applied to base and full height cabinets. See *Moldings and Millwork on page 926* and *Accessories Panel on page 655*.





Base cabinet with pilasters and feet



Wall cabinet with crown molding and light rail

## MAKE CABINET MOLDING POLYLINE

 Cabinet moldings can be converted to molding polylines, which allows you to make adjustments to their position and  display. To create a molding polyline that follows the exterior of a cabinet, select the cabinet and click the **Make Cabinet Molding Polyline** edit button.

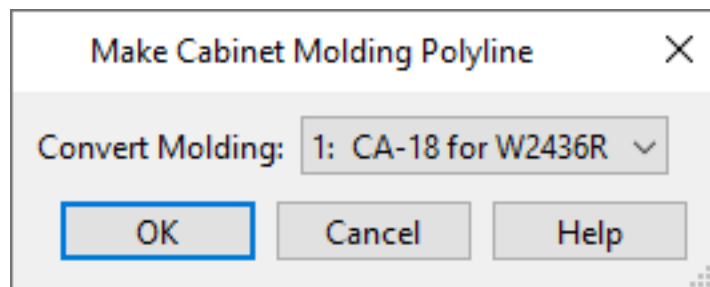

From the **Convert Molding** drop-down list, select the molding profile that you would like to convert from a cabinet molding to a molding polyline. The available options will be the molding profiles assigned to the selected cabinet.

When you convert a cabinet molding to a molding polyline, that molding is removed from the cabinet itself.

Cabinet molding polylines can be edited just like other molding polylines. Their shape and height can be altered and the molding profile can be changed. Additional molding profiles can also be assigned. See [Molding Polylines on page 935](#).

## COUNTERTOPS AND BACKSPASHES

The countertop thickness, overhang, corner shape, edge profile, and material for a selected base cabinet can be specified in the Cabinet Specification dialog. See [General Panel on page 644](#) and [Moldings // Profiles // Rails // Panels on page 927](#).

Backsplashes can be specified for base cabinets on the GENERAL panel of their specification dialogs, as well.

Custom Countertops, Counter Holes, and Backsplashes can also be created independent of base or wall cabinets. See [The Cabinet Tools on page 621](#).

## CABINET SHELVES

You can customize the shelves inside base, wall, and full height cabinet boxes. See [Cabinet Shelf Specification Dialog on page 658](#).

You can also specify the material assigned to a cabinet's shelves on the MATERIALS panel of the Cabinet Specification dialog. See [Cabinet Specification Dialog on page 643](#).

---

# Special Cabinets

There are a number of special cabinet shapes that can be specified. Certain requirements must be met before some special cabinet shapes can be specified. If the requirements are not met, a warning message will explain what is needed. See [Cabinet Specification Dialog on page 643](#).



Note: Only Standard cabinets can be the default cabinet Type. See [Cabinet Defaults on page 618](#).

## STANDARD CABINETS

Select **Build> Cabinet> Base Cabinet**  and click in plan view to place a standard, rectangular base cabinet.



## CORNER CABINETS

To create a corner cabinet, click as close to an inside wall corner as possible using either the **Base Cabinet** , **Wall Cabinet** , or **Full Height**  cabinet tool. A corner cabinet remains a corner cabinet when it is moved, edited or copied.

You can turn an existing cabinet into a corner cabinet by selecting “Corner” from the **Special** drop-down list in its specification dialog. See [General Panel on page 644](#).

- Before a corner cabinet can be specified in the Cabinet Specification dialog, the cabinet’s Width must be greater than its Depth.
- The **Left** and the **Right Side Widths** can be set independently for corner cabinets.



- You can specify a Diagonal Door on corner cabinets to create an angled corner cabinet. See [Front/Sides/Back Panel on page 648](#).



- The diagonal door on corner cabinets can be curved by entering a negative value in the second Right Side Width field. See [General Panel on page 644](#).



## EXPOSED END CABINETS

A cabinet that is merged on one side but not the other is referred to as an Exposed End.



Pilasters, feet, countertop overhangs and closed toe kicks all behave differently when groups of cabinets are merged:

- If multiple cabinets are joined together, only Exposed End cabinets have corner pilasters, cabinet feet, side counter overhangs, and closed toe kicks.
- If multiple joined cabinets have both **Front Pilasters** and **Corner Pilasters** specified, the Exposed End cabinets include corner pilasters and inside cabinets have front pilasters.
- If multiple cabinets are joined, inside cabinets share Front Pilasters.
- Corner pilasters and cabinet legs are eliminated on the back if the cabinet is against a wall, and on either side if it’s joined with another cabinet.



## END CABINETS

To turn a cabinet into an end cabinet, specify its Type as “Left End” or “Right End”.



- End Cabinets have an angled front and side.
- The cabinet width must be no greater than its depth for an end cabinet to be specified.

## RADIUS END CABINETS

To turn a cabinet into a radius end cabinet, specify its Type as “Left Radius End” or “Right Radius End”.



As you face the cabinet, a right radius end curves to the right, and a left radius end curves to the left.

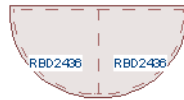

## PENINSULA RADIUS CABINETS

To turn a cabinet into an end cabinet, specify its Type as “Peninsula Radius”.



The radius can be adjusted by changing the Depth/Bow Depth value. See *General Panel on page 644*.

## ANGLED FRONT CABINETS

To assign an angled front to a cabinet, specify its Type as “Angled Front”.



- The length of the left and right side of an **Angled Front** cabinet can be defined by changing the Depth/Bow Depth value. See *General Panel on page 644*.

## BOW FRONT CABINETS

To assign a bow front to a cabinet, specify its Type as “Bow Front”.



- The bow depth of a **Bow Front** cabinet can be defined. See *General Panel on page 644*.
- The bow depth cannot exceed half the cabinet width.
- The doors and drawers on a **Bow Front** cabinet automatically match the curvature of the cabinet.

## KITCHEN ISLANDS

To create a kitchen island, simply place several cabinets back-to-back and/or side-to-side. Match the widths so that each cabinet back or side meets the back or side of only one other cabinet. If this is not done, the lines separating the cabinets cannot be suppressed.

A given side of a single cabinet cannot merge with the edges of two different cabinets. The example below shows two instances of cabinets placed back-to-back. Cabinet fronts and joining surfaces are shown.

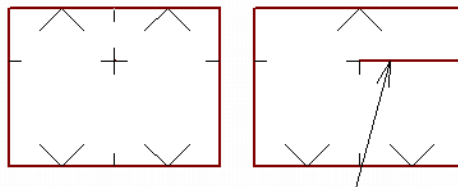

## BLIND CABINETS

Often, when two cabinets meet in a corner, one is partially hidden by the other. This partially hidden cabinet is called a “blind” cabinet. Chief Architect will resize and offset the front items of the partially hidden cabinet so that they are not located in the hidden portion of the cabinet face.



You can turn off this automatic behavior in the General Cabinet Defaults dialog. See [General Cabinet Defaults on page 619](#).

You can also create a blind cabinet manually by controlling the widths of a cabinet's left or right stile in its Cabinet Specification dialog. See [Front/Sides/Back Panel on page 648](#).

---

## Cabinet Specification Dialog

 Select one or more cabinets and click the **Open Object** edit button to open the Cabinet Specification dialog.

You can also open the specification dialog for the cabinet(s) associated with a schedule row. See [Open Row Object\(s\) on page 686](#).

If the selected cabinet is an imported symbol in a legacy plan, the Cabinet Symbol Specification dialog opens instead and has fewer options than the Cabinet Specification dialog.

The options in the Cabinet Specification dialogs are similar to the corresponding Cabinet Defaults dialog. See [Cabinet Defaults on page 618](#).

The Cabinet Specification dialogs have the following panels:

## GENERAL PANEL

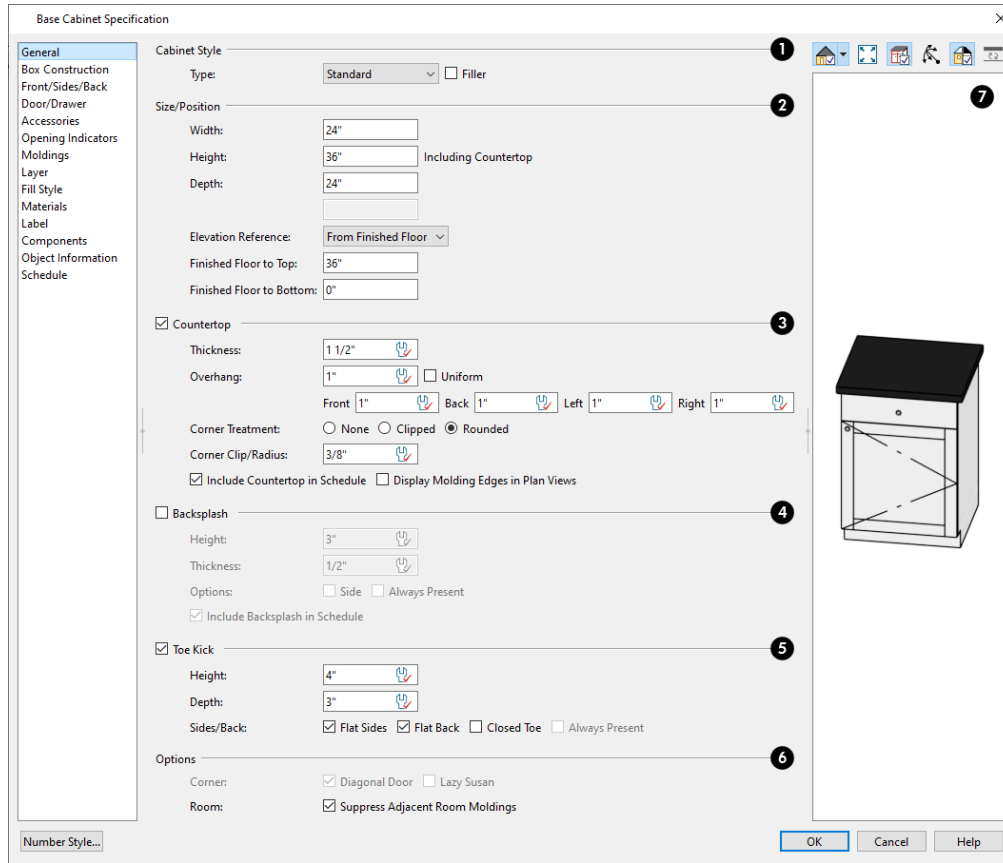

### 1 Cabinet Style

A number of **Cabinet Types** are available in the drop-down list. Certain requirements must be met before some types can be specified. Not available in the Cabinet Defaults dialogs. See [Special Cabinets on page 639](#).

- Check **Filler** to specify the selected cabinet as a filler of the same type instead of a true cabinet. See [Cabinet Fillers on page 624](#). Not available in the Cabinet Defaults dialogs.

### 2 Size/Position

The selected cabinet's dimensions and position relative to the floor can be specified here. Fractional values are supported to 1/16th of an inch (1 mm).

- Specify the **Width** of the cabinet box, as measured across the front of the cabinet box from left to right. This does not include the countertop overhang.
- Specify the **Height (Including Counter)** of the cabinet box, as measured from bottom to top. For base cabinets, this value includes the countertop thickness, but not the height of the backsplash.

Note: Height refers to the height of the entire cabinet, including countertop and toe kick. If you change the Countertop Thickness or Toe Kick Height, the cabinet's total height is not altered. Instead, the cabinet face height and the heights of face items change in response.

- Specify the **Depth** of the cabinet box, as measured from front to back. It does not include the thickness of overlay doors or the countertop overhang.
- For Corner cabinets, the **Width** and **Depth** fields are instead named **Right Side Width** and **Left Side Width**.
- For Corner and Bow Front cabinets, specify the **Bow Depth**. A positive number creates a bow and a negative number, an inside bow. Not available for Corner cabinets if Diagonal is unchecked on the Front panel. See *Front/Sides/Back Panel on page 648*.
- For Angled Front cabinets, specify the **Left Depth** and **Right Depth** rather than the Depth and Bow Depth.
- Select the **Elevation Reference** from the drop-down list. This determines where the next two settings are measured from and also affects their setting labels.
- Specify the **to Top** distance, measured from the Elevation Reference to the top of the cabinet's countertop.
- Specify the **to Bottom** distance, measured from the Elevation Reference to the bottom of the cabinet, including the toe kick.

### 3 Countertop

Specify the dimensions and style of the selected cabinet's **Countertop**, or uncheck this box to prevent it from having a countertop. Only available for base cabinets and fillers.

- Specify the countertop **Thickness**. Changing this value does not alter the cabinet height, but it does affect the height of face items. See *Front/Sides/Back Panel on page 648*.
- Specify the countertop **Overhang**. Uncheck **Uniform** to specify separate values for each side in the fields below, or leave it checked to use the same value for all sides. Overhangs do not generate on sides that are against a wall, free-standing appliance, Partition, or another Base or Full Height Cabinet. See *Cabinet Snapping and Aligning on page 625*.
- **Corner Treatment** - Specify **Clipped** or **Rounded** countertop corners. The options here are the same as those for the Cabinet Corner Treatment, but affect the countertop rather than the cabinet box. See *Box Construction Panel on page 647*.
- When Clipped or Rounded is selected, specify the **Corner Width**, which is measured from the original location of the corner to the point where the straight front edge ends.
- When **Include Countertop in Schedule** is checked, the selected cabinet's countertop is listed in any schedule set up to include Countertops. Uncheck this box to exclude the selected cabinet's countertop from schedules. See *Cabinet Schedules on page 630*.
- Check **Display Molding Edges in Plan Views** to draw the molding profile applied to the countertop in plan views, if there is one. When unchecked, only the countertop's Overhang is represented. See *Pilasters, Feet, and Moldings on page 638*.

### 4 Backsplash

Check the box beside **Backsplash**, then specify its dimensions and when it should generate, or leave this box unchecked to prevent the selected base or wall cabinet or filler from having a backsplash.

- Specify the backsplash **Height** and **Thickness**. Height is only available for base cabinets - not wall cabinets.
- Check **Side** to add the backsplash to the side of the cabinet if it is against a wall or a taller cabinet. Not available for Corner cabinets.

- Check **Always Present** to display the backsplash at all times. If unchecked, a backsplash is present only when the cabinet is against a wall.
- The **Backsplash to Base Below** check box is only available in legacy plan files if it was checked in the original program version. When checked, a backsplash extends from the selected wall cabinet down to the backsplash or countertop of the base cabinet below. If this box is unchecked and you click OK, the setting will be removed from the dialog.
- When **Include Backsplash in Schedule** is checked, the selected cabinet's backsplash is listed in any schedule set up to include Backsplashes. Uncheck this box to exclude the selected cabinet's backsplash from schedules. See *Cabinet Schedules on page 630*.

## 5 Toe Kick

Specify the dimensions and style of the selected cabinet's **Toe Kick**, or uncheck this box to prevent it from having a toe kick. Only available for base and full height cabinets and fillers. Regardless of the settings here, toe kicks do not generate on sides that are against a wall, free-standing appliance, Partition, or another Base or Full Height Cabinet.

- Specify the toe kick's **Height** and **Depth**. Changing the Height does not alter the cabinet height but does affect the heights of the cabinet face and face items.
- **Flat Sides** can be added to base and full height cabinets. Checking Flat Sides eliminates the toe kick area on the exposed end(s) of the cabinet.
- Check **Flat Back** to eliminate the toe kick on a cabinet with an exposed back. This does not eliminate the toe kick on the cabinet front.
- Check **Closed Toe** to extend the cabinet sides to cover the sides of the toe kick. If pilasters that do not extend to the floor are specified, checking this places a support block under them at Exposed Ends. See *Accessories Panel on page 655*.
- Check **Always Present** to preserve the Closed Toe at all times. When this is unchecked, the Closed Toe is removed where cabinets are side by side. Only available when Closed Toe is checked.

## 6 Options

- Uncheck **Diagonal Door** to create double doors at right angles instead of a single diagonal door. This option is checked by default in the Cabinet Defaults dialog and is only available for Corner Cabinets. See *Corner Cabinets on page 639*.
- Check **Lazy Susan** to indicate a lazy Susan in the cabinet's label and its appearance in plan view. This option does not display in 3D views.
- When **Suppress Adjacent Room Moldings** is checked, room moldings do not generate on walls where the selected cabinet touches them. Uncheck this box to allow room moldings to generate through the cabinet. See *Room Moldings on page 436*.

## 7 Preview

A preview of the selected cabinet displays on the right side of the panel. See *Dialog Preview Panes on page 22*.

## BOX CONSTRUCTION PANEL

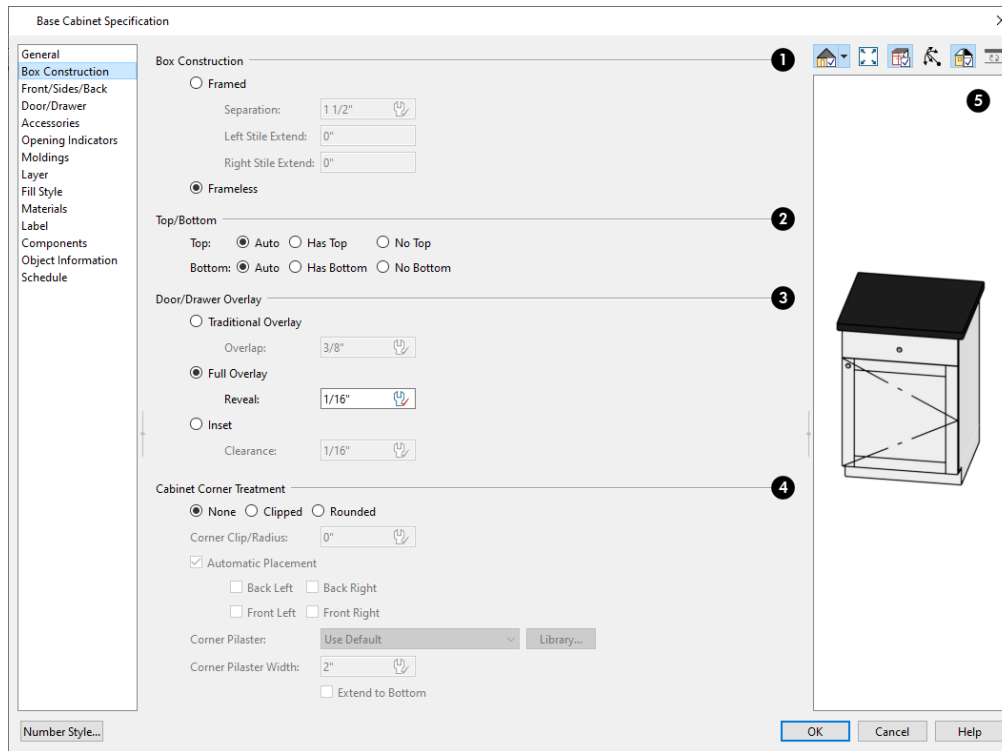

### 1 Box Construction

Define the **Box Construction** of the selected cabinet. Select **Framed** to create a traditional framed cabinet and enable the settings below, or choose **Frameless** for a European style cabinet.

- Specify the **Separation** value, which is the width of the horizontal face frame piece between doors, drawers, and other face items.
- The **Left** and **Right Side Extend** settings allow you to extend the front frame beyond the box sides. See [Cabinet Filler Tools on page 624](#).

### 2 Top/Bottom

Specify whether the selected cabinet box or filler has a **Top/Bottom**.

- By default, base cabinets do not have tops while wall and full height cabinets do.
- When the **Bottom Auto** option is selected and the selected cabinet's bottom-most face item is a Separation or a Blank Area, it will receive a bottom; if it is any other face Item Type, it will not. See [Cabinet Face Items on page 637](#).

### 3 Door/Drawer Overlay

See [Cabinet Construction on page 633](#).

- Select **Traditional Overlay**, then specify the **Overlap** value.
- Select **Full Overlay**, then specify the **Reveal**, which is the distance between door and drawer front items. This

serves as the default for the Left and Right Reveal settings on THE FRONT/SIDES/BACK panel.

- Select **Inset** to produce doors and drawers that are flush with the rails and stiles rather than overlaying it.

#### **4 Cabinet Corner Treatment**

Specify clipped or rounded corners for the selected cabinet's box. These settings are only available for Standard and Bow Front cabinet types. Corner Treatments can also be assigned to Corner cabinets; however, if a cabinet has Diagonal Doors specified, no Treatment is applied.

- Select **Rounded** to create rounded cabinet corners, then specify their Radius.
- Select **Clipped** to create 45° angled edges at the cabinet corners, then specify the Corner Clip distance.
- Select **None** for cabinet corners that are neither clipped nor rounded.
- Specify the **Corner Clip/Radius** value. The Corner Clip is measured from the original location of the cabinet corner along an edge to the point at which a Clipped corner begins, while the Radius is the radius of a rounded corner's arc. Not available if None is selected.
- When **Automatic Placement** is checked, the selected corner treatment is applied to all corners except those positioned against a wall or another cabinet of the same type. Base and Full Height cabinets also suppress corner treatments on one another; and, Base cabinet corner treatments are suppressed by Partitions and free-standing appliances. Uncheck this box to suppress each corner's treatment individually, below.
- When Automatic Placement is unchecked, specify which corner(s) to apply the selected Treatment to: **Back Left, Back Right, Front Left, and/or Front Right**.
- **Corner Pilaster** - Select the default corner pilaster, a pilaster from the Library, or None from the drop-down list. Only available when Clipped is selected as the treatment, above.
- Specify the **Corner Pilaster Width** value, measured across the front of the pilaster.
- Check **Extend to Bottom** to extend corner pilasters to the bottom of the toe kick. When unchecked, pilasters stop at the top of the toe kick.



Front Pilasters are specified on the Accessories panel. See [Accessories Panel on page 655](#).

#### **5 Preview**

A preview of the selected cabinet displays on the right side of the panel. See [Dialog Preview Panes on page 22](#).

#### **FRONT/SIDES/BACK PANEL**

If you click on a cabinet face item in the preview on the right side of the dialog, the FRONT/SIDES/BACK panel will become active and that face item will be selected and can be edited.



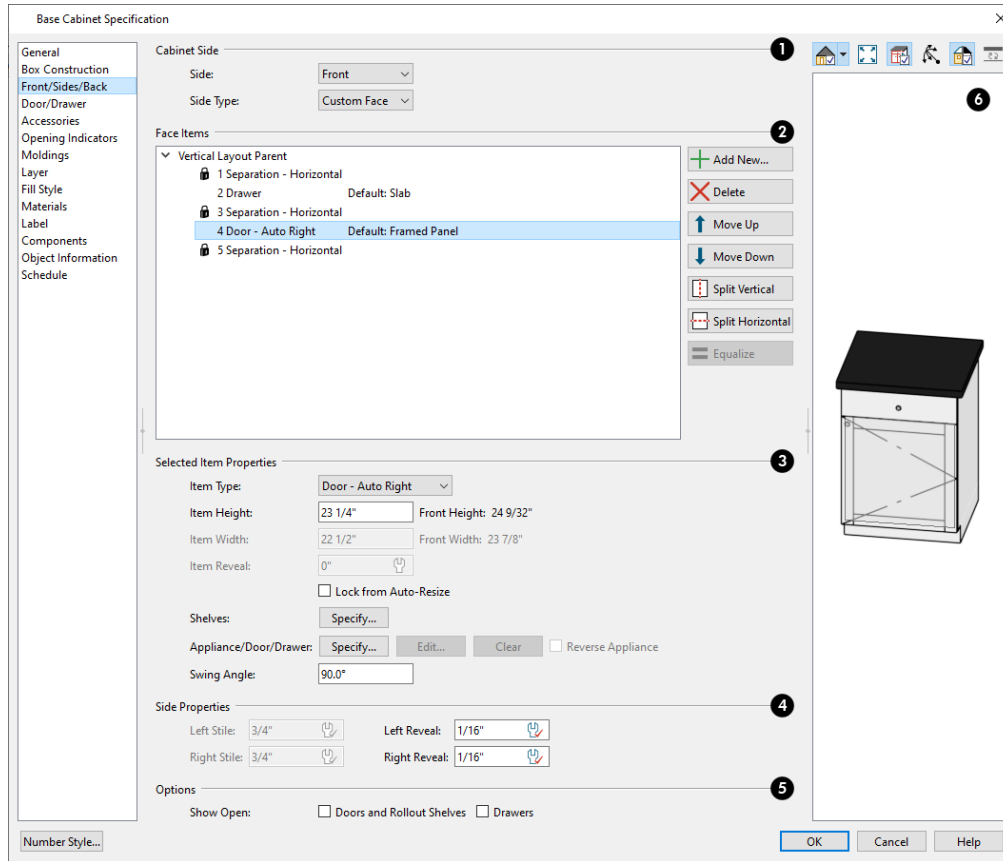

## 1 Cabinet Side

Select which **Cabinet Side** you would like to edit: the Front, Back, Left or Right side.

- Assign a **Side Type** to the selected Side. Only “Use Default” and “Custom Face” are available for the Front. The options are:
- Select “Use Default” to use the default configuration set in the Cabinet Defaults dialog. See *Cabinet Defaults on page 618*.
- Select “Finished” to specify the selected side as finished or “Unfinished” to specify it as unfinished. “Finished” and “Unfinished” are only used in Cabinet Schedules. See *Columns to Include on page 689*.
- Select “Auto Finished” to finish the side only when it is not adjacent to another cabinet or a wall.
- Select “Paneled” to apply a panel to the selected side.
- Select “Auto Paneled” to apply a panel to the side only when it is not adjacent to another cabinet or a wall.
- Select “Match Front” to apply the same face items as the cabinet front to the selected side.
- Select “Custom Face” to enable the Face Items settings below.
- Select "None" to generate no face items on the selected side or back: including the frame, if specified.

## 2 Face Items

Most of the **Face Items** settings are only active when a door, drawer, or other face item is selected. To select a face item,

click on its name in the list or click on it in the preview on the right.

When a face item is selected, it is highlighted in the list as well as in the preview; its attributes can be edited and the list can be navigated using the arrow and number keys. The vertical frame pieces on the sides of the cabinet front are referred to as stiles and cannot be selected in the preview. See *Cabinet Face Items on page 637*.

- A numbered tree list of face items displays here. Item numbers start at the top of the cabinet and go down the face to the bottom of the cabinet. Item 1 is usually the top face frame Separation, or rail. The selected face item is highlighted; if no item is selected, the “Vertical Layout Parent” heading will be highlighted.
- The name of inserted library objects associated with doors, drawers, and appliance items is stated in the list. If a door or drawer is using the default style, its name will be preceded by "Default".
- Click **Add New** to add a new face item directly below the currently selected item. When a face item is added, the height of the lowest item on the cabinet front is reduced to make room for the new item. If you click **Add New** with no face item selected, the new item is added to the bottom of the cabinet face.
- In the New Cabinet Face Item dialog, define the **Item Type**, **Item Height**, and click OK. If the Item Type is “Separation”, you can check **Default** to use the default Separation Height.

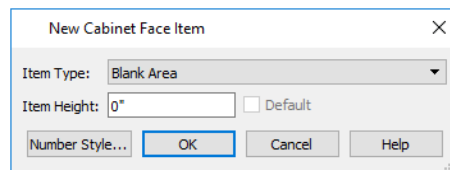

- Click **Delete** to remove the selected face item. When an Auto Left, Auto Right, Left, Right, or Double Door is deleted, it is replaced by an Opening; when other face item types are deleted, the height of the lowest item is increased to make up the difference. You can also press the Delete key on the keyboard.

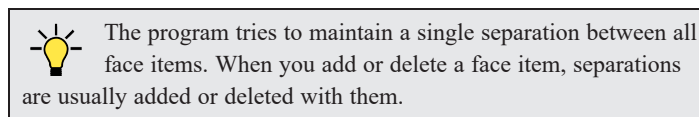

- Click **Move Up** to move the currently selected item up one position, switching places with the item directly above.
- Click **Move Down** to move the currently selected item down one position, switching places with the item directly below.
- When the selected face item is part of a “Layout - Horizontal”, the **Move Left** and/or **Move Right** buttons will be available instead. Click either to have the selected item switch places with its neighbor.
- Click **Split Vertical** to divide the selected face item into two separate side-by-side items of the same Item Type and Height. A vertical separation is added between them and together the three new items have the same Width as the original item. Not available for Horizontal or Vertical Layouts, Appliances, Separations, or for items 1 1/2” (50 mm) wide or less.
- Click **Split Horizontal** to divide the selected face item into two separate items of the same Item Type and Width, stacked one above the other. A horizontal separation is added between them and together the three new items have the same Height as the original item. Not available for Horizontal or Vertical Layouts, Appliances, Separations, or for items 1 1/2” (51 mm) tall or less.
- Click **Equalize** to make the sizes of a face item’s sub-items equal in size. Only available if the selected item is a Vertical or Horizontal Layout with sub-items.

### 3 Selected Item Properties

- Choose the selected face item's **Item Type** from the drop-down list:

Item Type	Special Behaviors
<b>Blank Area</b>	Creates a solid, flat surface.
<b>Horizontal Layout</b>	Creates a group of identical, side-by-side items separated by vertical separations.
<b>Vertical Layout</b>	Creates a group of identical, stacked items separated by horizontal separations.
<b>False Drawer and False Double Drawer</b>	Assumes the appearance of specified the drawer style, including hardware.
<b>Drawer and Double Drawer</b>	Creates a single or double drawer of the specified drawer style, including hardware.
<b>Cutting Board</b>	Creates a cutting board.
<b>Auto Right and Auto Left Door</b>	Become double doors when the width of the opening is greater than the Auto Door Threshold. See <i>General Cabinet Defaults on page 619</i> .
<b>Left, Right, and Double Door</b>	As specified, regardless of opening width.
<b>Door Panel</b>	Assumes the appearance of the specified door style but with no hardware.
<b>Opening</b>	Creates an opening with shelves.
<b>Separation</b>	Creates a horizontal rail, or frame piece.
<b>Appliance</b>	Creates an opening with no shelves, for which an appliance can be specified.

- Specify the selected face item's **Item Height**. Fractional values are supported to 1/16th of an inch (1 mm). For doors and drawers, this is the height of the opening: the selected door or drawer's Front Height is reported to the right for reference. A door or drawer's front height is equal to its Height plus its top and bottom Vertical Overlap. For best results, edit face item heights starting at the top of the cabinet and work down. See *Cabinet Face Items on page 637*.
- Specify the selected face item's **Item Width**. Fractional values are supported to 1/16th of an inch (1 mm). For doors and drawers, this is the width of the opening: the selected door or drawer's Front Width is reported to the right for reference. Only available for components of a Horizontal Layout.
- Check **Lock from Auto Resize** to prevent the selected face item from resizing when the cabinet is resized, new face items are added, or when the **Equalize** button is clicked.

- **Shelves** - Click the **Specify** button to open the Cabinet Shelves Specification dialog and specify the shelf configuration for a selected Door or Opening Face Item. See *Cabinet Shelf Specification Dialog on page 658*.
- When an **Appliance/Door/Drawer** or panel is selected, click the **Specify** button to choose an appliance from the Library or to customize the selected door, drawer, or panel's front style and hardware. The options available depend on the type of face item currently selected. See *Select Library Object Dialog on page 974* and *Door/Drawer Panel on page 652*.
- Click the **Edit** button to open the selected appliance's Fixture Specification dialog. See *Symbol Object Specification Dialogs on page 986*.
- Click the **Clear** button to remove the selected appliance from the cabinet or to reset the selected door or drawer so it uses hardware and front style assigned to the cabinet.
- Check **Reverse Appliance** to reverse the selected face item from left to right: for example, to move a dishwasher's controls from the left side to the right. Only available when an "Appliance" item is selected. See *Inserted Objects on page 973*.
- Specify the **Percent Open** of a selected drawer, which controls how far it is shown open in plan and 3D views. See *Cabinet Doors and Drawers on page 629*.
- Specify the **Swing Angle** of a selected door in plan and 3D views. An angle of 0° displays the door completely closed and an angle of 180° displays it as wide open.

#### 4 Side Properties



- Specify the widths of the **Left Stile** and **Right Stile**. Only available when the selected cabinet has **Framed Box Construction** specified. See *Framed and Frameless Cabinets on page 637*.
- Specify the **Left Reveal** and **Right Reveal**. For Framed cabinets, this is the reveal on the Left and Right Stiles; for Frameless cabinets, this is the reveal on the sides of cabinet box.

#### 5 Options

- Specify which types of front items you would like to **Show Open** in plan, 3D, and cross section/elevation views. See *Cabinet Doors and Drawers on page 629*.

#### 6 Preview

A preview of the selected cabinet displays on the right side of the panel. See *Dialog Preview Panes on page 22*.

- **Select Cabinet Face Item**  mode is active by default and allows you to click on a face item like a door, drawer, or separation in the preview to select it for editing. The selected face item is highlighted in grey.
- **Mouse-Orbit Camera**  mode allows you to orbit around the preview of the cabinet. When this is active, you can right-click on a front item to select it.
- Face items identified as "Horizontal Layout" in the list on the left cannot be selected in the preview.

### DOOR/DRAWER PANEL

The settings on the DOOR/DRAWER panel allow you to control the appearance of the selected cabinet's doors, drawers and hardware.

Similar settings are also found in the Door, Drawer, and Side Panel Face Item Specification dialogs, which allow you to customize the door, drawer, and panel style as well as the hardware for individual cabinet face items. See *Front/Sides/Back Panel on page 648*.

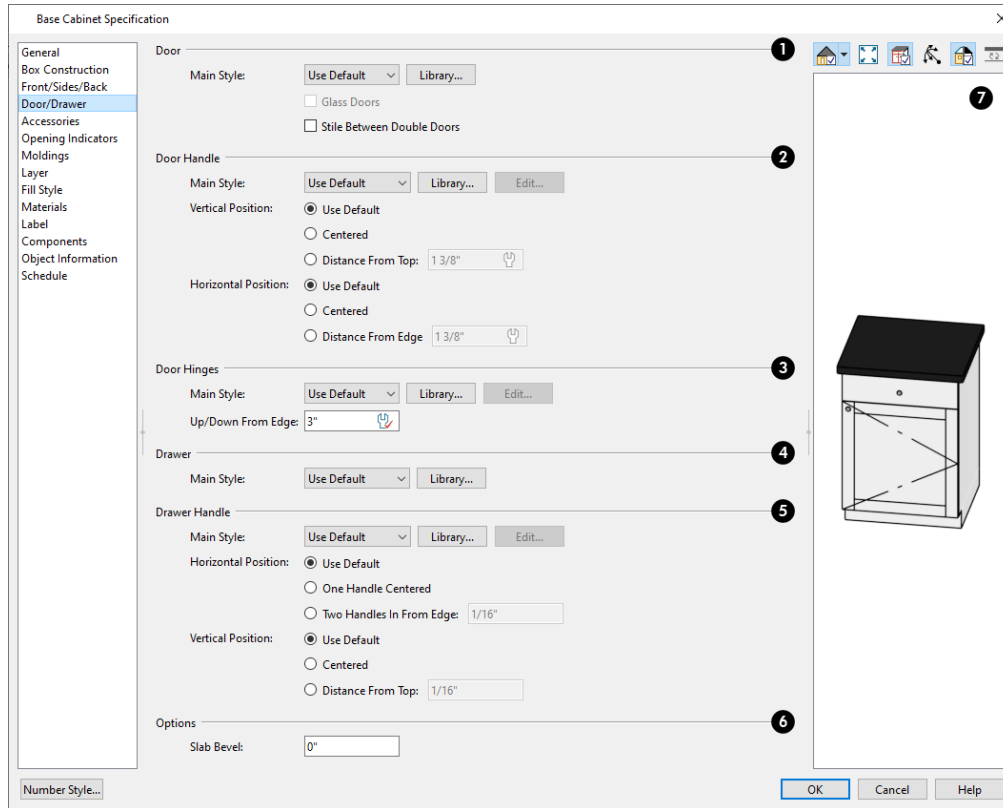

## 1 Door

- Select a door **Main Style** from the drop-down list. See *Doors, Drawers and Panels on page 637*.
- Select “Use Default” to apply the door style specified in the defaults dialog for the selected cabinet’s type. See *Cabinet Defaults on page 618*.
- Select “Slab Doors” to apply a flat door front or “Framed Doors” to apply a door with a frame and flat panel front.
- Select “Library” or click the **Library** button to select a cabinet door from the library. If a library door has been previously selected, its name will display in the list. See *Select Library Object Dialog on page 974*.
- Check **Glass Doors** to use a glass material for the panel of Framed doors or for the entire door for Slab doors. Not available when “Library” is the selected door Style.
- Check **Stile Between Doors** to separate double doors and double drawers with a stile. Other face items types are not affected by this setting.

## 2 Door Handle

- Select a door handle **Main Style** from the drop-down list or choose one from the **Library**.
- When a handle from the Library is selected, you can click the **Edit** button to customize the handle's size and angle. See *Hardware Size/Orientation Dialog on page 659*.
- Specify the **Vertical Position** of the door handle: Choose **Use Default** to use the default position; **Centered** for a handle centered on the door face; or specify a **Distance From Top**.

- Specify the **Horizontal Position** of the door handle: Choose **Use Default** to use the default position, **Centered** for a handle centered on the door face, or specify the handle's **Distance From Edge**.

### 3 Door Hinges

- Select a door hinge **Main Style** from the drop-down list or choose one from the **Library**.
- When a handle from the Library is selected, you can click the **Edit** button to customize the handle's size and angle. See *Hardware Size/Orientation Dialog on page 659*.
- Specify the location of the hinges **Up/Down From Edge**, as measured from the door edge. If the cabinet door is more than 35 1/4" (880 mm) high, three hinges will be created instead of two.

### 4 Drawer

Select a drawer **Main Style** from the drop-down list or choose one from the **Library**. For best results, "Framed" drawers should be at least 6" (150 mm) high.

### 5 Drawer Handle

- Select a drawer handle **Main Style** from the drop-down list or choose one from the **Library**.
- When a handle from the Library is selected, you can click the **Edit** button to customize the handle's size and angle. See *Hardware Size/Orientation Dialog on page 659*.
- Specify the **Horizontal Position** of the drawer handle(s): Choose **Use Default** to use the default position; **One Handle Centered** for a single handle centered on the drawer face; or **Two Handles In From Edge** for two handles set in from the drawer sides by the value specified in the text field.
- Specify the **Vertical Position** of the drawer handle(s): Choose **Use Default** to use the default position, **Centered** for handle(s) centered on the drawer face, or specify the handle's **Distance From Top**.

### 6 Options

- Enter a **Slab Bevel** width to create beveled edges on Slab drawers and doors. The bevel width, as viewed from the front, has a maximum value of 3" (75 mm). Framed and Library doors are not affected by this setting.

### 7 Preview

A preview of the selected cabinet displays on the right side of the panel. See *Dialog Preview Panes on page 22*.

## DOOR AND DRAWER FACE ITEM SPECIFICATION DIALOGS

Additional settings are available in the Door and Drawer Face Item Specification dialogs. See *Storage and Organization Inserts on page 624*.

The **Door Back Inserts** settings allow you to choose one or more storage items for the back of a selected door.

- A drop-down list of the inserts assigned to the selected door displays here. Select the name of an object to edit it or remove it from the list.
- Click the **Add New** button to open the Select Library Object dialog and add a new symbol to the list. See *Select Library Object Dialog on page 974*.
- Click the **Replace** button to remove the selected symbol and replace it with a new one from the library. Only available when an object is already selected.
- Click the **Delete** button to remove the currently selected symbol from the list.

- Select **Top to Bottom** to place the first insert at the top of the selected door and place additional ones evenly spaced below it.
- Select **Bottom to Top** to place the first insert at the bottom of the selected door and place additional ones evenly spaced above it.

The **Drawer Box/Pullout** setting allows you to select an insert for a selected drawer from the library.

## ACCESSORIES PANEL

The settings on the ACCESSORIES panel let you apply pilasters, feet, and panels to the selected cabinet(s), as well as specify a fixture set into the countertop. The accessories specified here can be seen in 3D views, schedules, and the Materials List; however, with the exception of Top Appliance/Fixtures, they do not display in plan view.

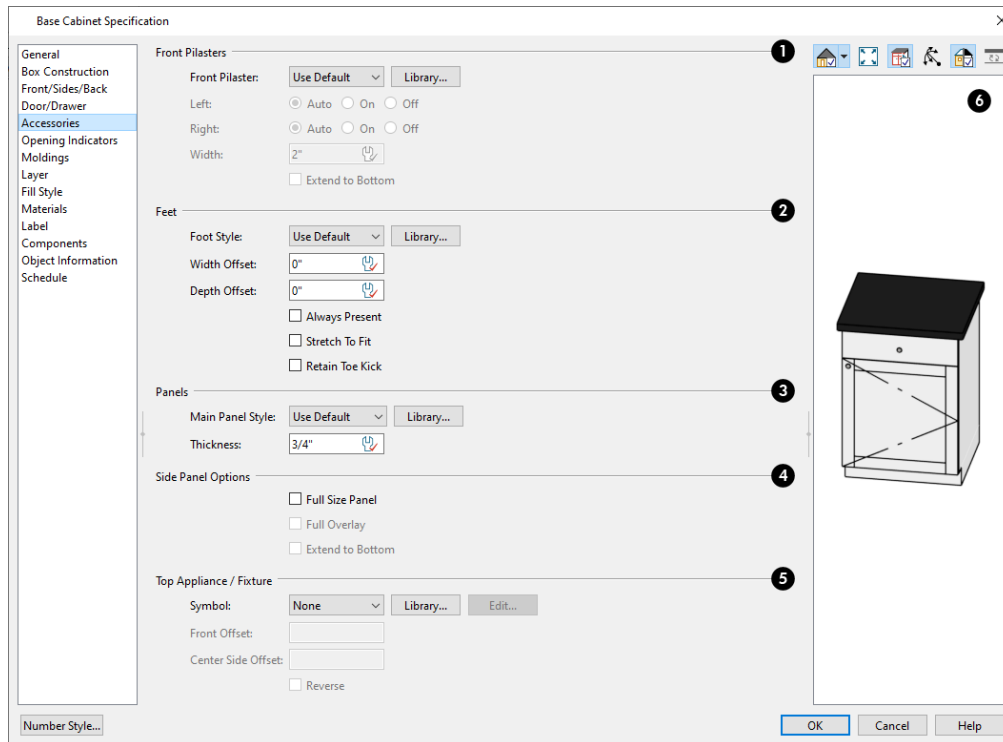

### 1 Pilasters

Available for Standard and Corner cabinet(s). See [Editing Cabinet Styles on page 636](#).

- **Front Pilaster** - Select the Default front pilaster, a pilaster from the Library, or None.
- Specify how the **Left** and **Right** pilasters build: Select **Auto**, **On**, or **Off**.
- When **Auto** is selected, adjacent cabinets with the same Front Pilaster specified will share a single pilaster centered along their line where they meet, instead of each having its own.
- Specify the **Corner Pilaster Width** of the selected cabinet's pilasters. This value applies to both front and corner pilasters.
- Check **Extend to Bottom** to extend front and corner pilasters to the bottom of the toe kick. When this is unchecked, pilasters stop at the top of the toe kick.



Corner Pilasters are specified on the Box Construction panel. See [Box Construction Panel on page 647](#).

## 2 Feet

Available for Standard or Bow Front cabinet(s). Select the Default cabinet foot, a cabinet foot from the Library, or None. Not available for wall cabinets. See [Editing Cabinet Styles on page 636](#).

- Specify the **Width Offset**, which is the offset of the cabinet feet relative to the sides of the cabinet box.
- Specify the **Depth Offset**, which is the offset of the cabinet feet relative to the front and back of the cabinet box.
- Check **Always Present** to place cabinet feet under the selected cabinet regardless of where it is located. When checked, any adjacent cabinet edges will display feet as well. When unchecked, the cabinet will only receive feet along its outside edge if it is an end cabinet.
- Check **Stretch to Fit** to resize the cabinet feet so that they extend from each corner to the midpoint of each edge. Only affects cabinet foot symbols with stretch planes defined. See [Stretch Planes and Zones on page 983](#).
- Check **Retain Toe Kick** to place a toe kick under the cabinet. When unchecked, the toe kick is suppressed.

## 3 Panels

See [Front/Sides/Back Panel on page 648](#).

- Choose “Use Default” or select a Slab, Framed, or Library **Panel Style** from the drop-down list. You can specify whether a panel is applied or inset by selecting the desired Item Type.
- Click the **Library** button to select a panel style from the Library Browser. Cabinet doors are typically used, although drawers can be used, as well. See [Select Library Object Dialog on page 974](#).
- Specify the selected panel’s **Thickness**.

## 4 Side Panel Options

- Check **Full Size Panel** to apply a single panel to the entire side. When unchecked, the panel uses the same Style and Overlap values as the front. If the cabinet has multiple levels of doors on its front, the side will have matching panels.
- Check **Full Overlay** to extend Left and Right Side Panels to the outer surfaces of the cabinet’s front and back, including any doors, panels, or finishes that may be present.
- Check **Extend to Bottom** to extend panels on the Left, Right, or Back Sides to the bottom of the cabinet, including the toe kick.

## 5 Top Appliance/Fixture

The **Top Appliance/Fixture** settings apply to a fixture inserted into a base cabinet’s countertop. These settings are not available in the Base Cabinet Defaults dialog. See [Built-In Sinks and Appliances on page 623](#).

- Select a fixture **Symbol** from the drop-down list, or choose “None”. If a fixture is inserted into the countertop, its name will be listed. If no top fixture is present, you can select “Library” to select a fixture symbol from the Library.
- Specify the **Front Offset**, which is the distance from the front of the fixture to the front of the cabinet box. A positive value offsets the fixture towards the back of the cabinet while a negative value moves it forward.



- Specify the **Center Side Offset**, which is the distance between the fixture’s center and that of the cabinet. A positive value offsets the fixture to the right while a negative value offsets it to the left.
- Check **Reverse** to reverse the selected fixture from left to right: for example, to move a cooktop’s controls from the left side to the right. See *Inserted Objects on page 973*.

## 6 Preview

A preview of the selected cabinet displays on the right side of the panel. To see the cabinet’s pilasters and feet, you may want to zoom in. See *Dialog Preview Panes on page 22*.

### OPENING INDICATORS PANEL

The settings on the OPENING INDICATORS panel allow you to control whether an opening indicator displays on the selected cabinet’s door(s) in camera views. See *Opening Indicators Panel on page 570*.

### MOLDINGS PANEL

The settings on the MOLDINGS panel allow you to assign one or more horizontal moldings around the selected cabinet. See *Editing Cabinet Styles on page 636*.

For information about the settings here, see *Moldings // Profiles // Rails // Panels on page 927*.

### LAYER PANEL

The LAYER panel is found in the specification dialogs for many different objects. For more information, see *Layer Panel on page 186*.

### FILL STYLE PANEL

The settings on the FILL STYLE panel affect the appearance of the selected cabinet in plan view. For more information, see *Fill Style Panel and Dialogs on page 193*.

### MATERIALS PANEL

The settings on the MATERIALS panel affect the appearance of the selected cabinet in 3D views. For information about these settings, see *Materials Panel on page 1055*.

Some material options may be disabled if the selected cabinet is a manufacturer symbol.

### LABEL PANEL

Cabinet labels display in plan and cross section/elevation views when the “Cabinets, Labels” layer is turned on and use the Text Style assigned to that layer. See *Cabinet Labels on page 630*.

For more information about the settings on this panel, see *Label Panel on page 700*.

Note: If you choose Use Callout for Label in the Cabinet Schedule Specification dialog, the settings here are overridden and the schedule label is used instead.

## COMPONENTS PANEL

The information on the COMPONENTS panel can be used in the materials list. For more information, see [Components Panel on page 1330](#).

## OBJECT INFORMATION PANEL

The information entered on the OBJECT INFORMATION panel can be used in schedules and the materials list. For more information, see [Object Information Panel on page 1331](#).

## SCHEDULE PANEL

The settings on the SCHEDULE panel determine which schedule categories the selected cabinet is included in. See [Schedule Panel on page 704](#).

---

# Cabinet Shelf Specification Dialog

In the Base Cabinet, Wall Cabinet, or Full Height Cabinet Specification dialog, select a door or opening face item and click the **Specify Shelves** button to open the Cabinet Shelf Specification dialog. See [Front/Sides/Back Panel on page 648](#).

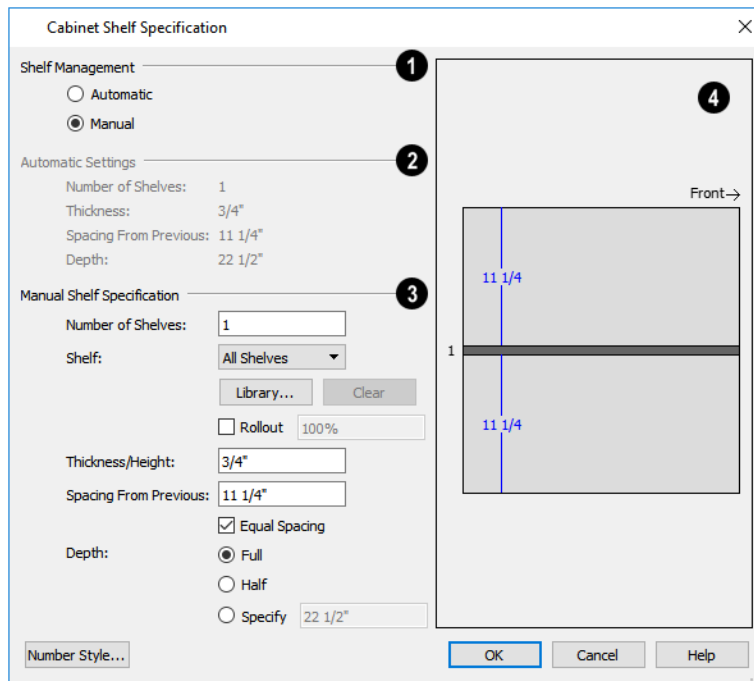

### 1 Shelf Management

Specify how shelves in the selected face item are created.

- By default, cabinet doors and openings receive **Automatic** cabinet shelves. The number of shelves, shelf type, thickness, spacing, and depth display below.
- Select the **Manual** radio button to specify the shelving for the selected door or opening. If the cabinet is resized after shelving has been manually edited, the specifications are maintained, but all shelves may not display in all situations.

**2 Automatic Settings**

Displayed for reference only.

**3 Manual Shelf Specification**

The following settings are available when **Manual** is selected, above:

- Specify the total **Number of Shelves** in the selected door or opening front item.
- Select a **Shelf** from the drop-down list to customize its settings. To edit all shelves at once, choose “All Shelves”.

Note: If “All Shelves” is selected after changes are made to an individual shelf, “No Change” may display in the settings that follow.

- Click the **Library** button to select a shelf, storage, or organization object from the Library Browser. See *Inserted Objects on page 973*.
- Click the **Clear** button to restore the default shelf style.
- Check **Rollout**, then specify the amount that the shelf rolls out when set to Show Open. Only available for Standard cabinets. See *Rollout Shelves and Storage on page 629*.
- Specify the **Thickness/Height** of the shelves or storage item.
- Specify the **Spacing From Previous**, which is the distance from the bottom of the selected shelf to the top of the shelf below it.
- If the **Spacing From Previous** value is changed, **Equal Spacing** will become unchecked. Check this box to produce evenly space the shelves within the selected cabinet front item.
- Specify the selected shelf’s **Depth**: choose **Full**, **Half**, or **Specify** a custom value in inches (mm).

**4 Preview**

The preview shows shelf numbers and spacing. Shelf thickness and depth are also represented. Press the Tab key to update the preview as changes are made.

## Hardware Size/Orientation Dialog

In the Base Cabinet, Wall Cabinet, or Full Height Cabinet Specification dialog, click the **Edit** button associated with either door/drawer handles or drawer hinges to open the Cabinet Shelf Specification dialog. See *Door/Drawer Panel on page 652*.

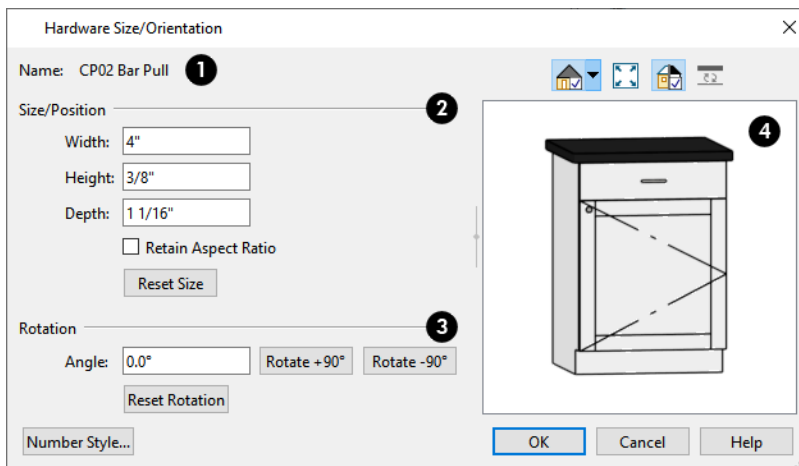

**1 Name**

The Name of the selected hardware symbol is reported here for reference.

**2 Size/Position**

- Specify the **Width**, **Height**, and **Depth** of the object.
- Check **Retain Aspect Ratio** to maintain the ratio between the object’s Height, Width, and Depth when it is resized in this dialog.
- Click **Reset Size** to reset the symbol’s original, unmodified size. The symbol’s elevation is not affected by this option.

**3 Rotation**

- Specify an exact **Angle** by typing it in the text field.
- Click the **Rotate +90°** or **Rotate -90°** button to add or subtract 90° from the Angle value.

**4 Preview**

The preview shows the hardware's containing cabinet with the specified hardware. See *Dialog Preview Panes on page 22*.

## Shelf/Partition Specification Dialog

Select a shelf or partition and click the **Open Object** edit button to open the Shelf Specification or Partition Specification dialog.

The options in these specification dialogs are similar to the corresponding defaults dialogs. See *Cabinet Defaults on page 618*.

### GENERAL PANEL

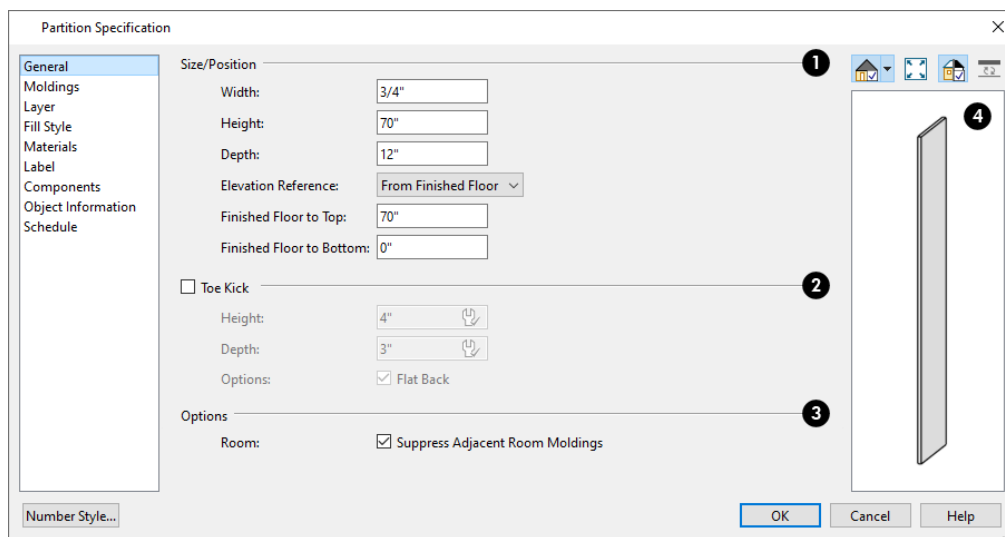

**1 Size/Position**

Specify the **Height**, **Width**, and **Depth** of the shelf or partition.

- Select the **Elevation Reference** from the drop-down list. This determines where the next two settings are measured from and also affects their setting labels.
- Specify the **to Top** distance, measured from the Elevation Reference to the top of the shelf or partition.
- Specify the **to Bottom** distance, measured from the Elevation Reference to the bottom of the shelf or partition.

## 2 Toe Kick

Specify the dimensions of a selected Partition's Toe Kick, or uncheck this box to prevent it from having a toe kick. Only available for Partitions.

- Specify the toe kick's **Height** and **Depth**. Changing the Height does not alter the Partition's height.
- Check **Flat Back** to eliminate the toe kick on a Partition with an exposed back. This does not eliminate the toe kick on the Partition's front.

## 3 Options

- When **Suppress Adjacent Room Moldings** is checked, room moldings do not generate on walls where the selected object touches them. Uncheck this box to allow room moldings to generate through the object.

## 4 Preview

A preview of the selected object displays on the right side of the panel. See *Dialog Preview Panes on page 22*.

## FILL STYLE PANEL

The settings on the FILL STYLE panel affect the appearance of the selected object in plan view.

## MOLDINGS PANEL

The settings on the MOLDINGS panel allow you to apply molding to the selected object. For information about these settings, see *Moldings // Profiles / Rails / Panels on page 927*.

## LAYER PANEL

For information about the settings on this panel, see *Layer Panel on page 186*.

## MATERIALS PANEL

The settings on the MATERIALS panel affect the appearance of the selected object in 3D views. For information about these settings, see *Materials Panel on page 1055*.

## LABEL PANEL

Shelf and Partition labels display in plan and cross section/elevation views when the “Cabinets, Labels” layer is turned on and use the Text Style assigned to that layer. The Automatic Labels for Shelves and Partitions are blank, but you can specify custom labels if you wish. See *Cabinet Labels on page 630*.

For more information about the settings on this panel, see *Label Panel on page 700*.

## COMPONENTS PANEL

The information on the COMPONENTS panel can be used in the materials list. For more information, see [Components Panel on page 1330](#).

## OBJECT INFORMATION PANEL

The information entered on the OBJECT INFORMATION panel can be used in schedules and the materials list. For more information, see [Object Information Panel on page 1331](#).

## SCHEDULE PANEL

The settings on the SCHEDULE panel determine which schedule categories the selected cabinet is included in. See [Schedule Panel on page 704](#).

---

# Custom Countertop Specification Dialog



Select a custom countertop and click the **Open Object** edit button to open the Custom Countertop Specification dialog.

## GENERAL PANEL

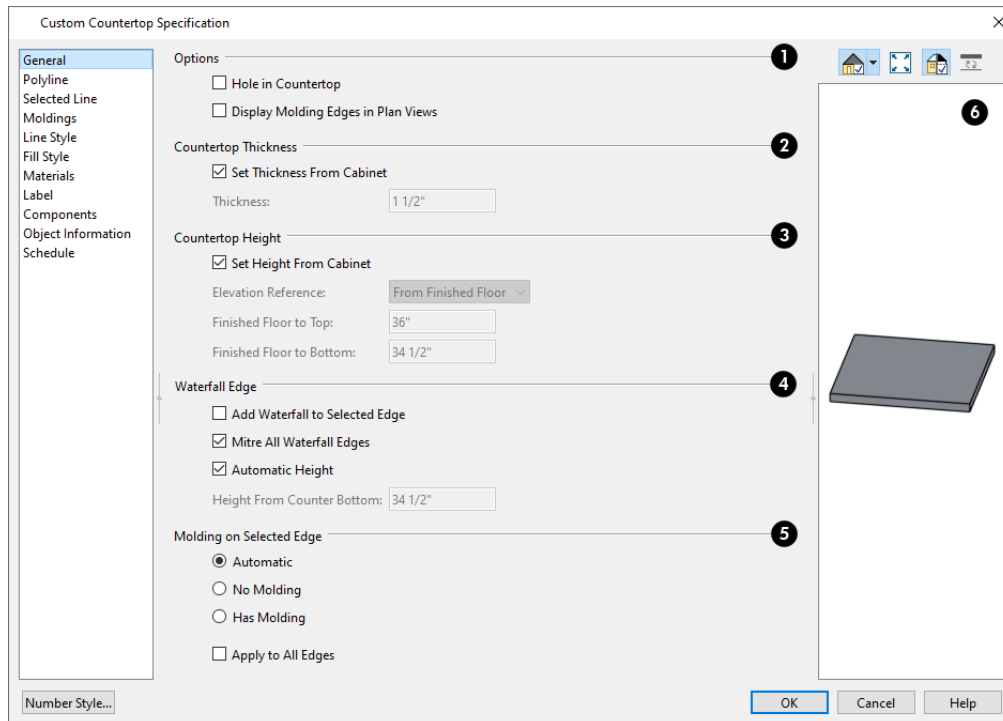

### 1 Options

- Check **Hole in Countertop** to convert the selected countertop, which must be contained within another single Custom Countertop, into a countertop hole.

- Check **No Molding On Selected Edge** to turn off the display of molding on the selected edge. Only has an effect when a molding is specified for the countertop on the MOLDINGS panel of this dialog.
- Check **Display Molding Edges in Plan Views** to display two edge lines instead of one, indicating the width of any molding applied to the countertop. Only has an effect when a molding profile is specified for the countertop.

## 2 Countertop Thickness

- Uncheck **Set Thickness From Cabinet**, then specify the Thickness of the selected Custom Countertop below. When this is checked, the thickness is inherited from the cabinet below or from the Base Cabinet Defaults dialog if no cabinet is present below.

## 3 Countertop Height

- Uncheck **Set Height from Cabinet**, then specify the height of the selected Custom Countertop using the settings below. When this is checked, Countertop height is determined by the cabinet below or by the default base cabinet counter thickness if no cabinet is present below.
- Select the **Elevation Reference** from the drop-down list. This determines where the next two settings are measured from and also affects their setting labels.
- Specify the height **to Top**, which is measured from the selected Elevation Reference to the top of the countertop.
- Specify the height **to Bottom**, which is measured from the selected Elevation Reference to the bottom of the countertop.

## 4 Waterfall Edge

Control whether the selected countertop edge has a waterfall and specify its attributes. See [Waterfall Countertops on page 628](#).

- Check **Add Waterfall to Selected Edge** to add a vertical extension to the selected edge of the countertop.
- Uncheck **Mitre All Waterfall Edges** to create butt joints with seams that may be visible in some views where the waterfall meets the horizontal countertop and any adjacent waterfall edges. When checked, these joints are mitered so the only visible seams are located at the corners.
- When **Automatic Height** is checked, the waterfall builds down to the floor height countertop's room, or the default floor height for the current floor if it is not in a room. Uncheck this to specify the waterfall's vertical height, below.
- Specify the **Height from Counter Bottom**, measured from the bottom of the horizontal countertop to the bottom of the waterfall.

## 5 Molding on Selected Edge

An edge profile for the selected counter can be specified on the Moldings panel. See [Selected Edge on page 212](#).

- Select **Automatic** to remove the edge profile from the selected edge when it is positioned against a wall and generate it otherwise.
- Select **No Molding** to remove the edge profile from the selected edge regardless of where it is positioned.
- Select **Has Molding** to generate the edge profile on the selected edge regardless of where it is positioned.
- Check **Apply to All Edges** to apply the option specified for the currently selected edge to all edges of the countertop. This is an action rather than a state: the next time this dialog is opened, this box will be unchecked.

## 6 Preview

A preview of the selected countertop displays on the right side of the panel. See [Dialog Preview Panes on page 22](#).

## **POLYLINE PANEL**

The POLYLINE panel states the length of the countertop's **Perimeter**, its **Area**, and its **Volume**. See *Polyline Panel on page 317*.

If the selected countertop has any Holes, they will be subtracted from the **Area** and **Volume** values. See *Custom Counter Holes on page 622*.

## **SELECTED LINE/ARC PANEL**

The SELECTED LINE panel is available when the selected edge is a line as opposed to an arc. For more information, see *Line Panel on page 304*.

The SELECTED ARC panel is available when the selected edge has been converted to an arc. For more information, see *Arc Panel on page 312*.

See, too, *Selected Edge on page 212* and *Change Line/Arc on page 256*.

## **MOLDINGS PANEL**

The settings on the MOLDINGS panel allow you to apply an edge profile to the selected countertop. For information about these settings, see *Moldings // Profiles / Rails / Panels on page 927*.

## **LINE STYLE PANEL**

For information about the settings on this panel, see *Line Style Panel on page 305*.

## **FILL STYLE PANEL**

The settings on the FILL STYLE panel affect the appearance of the selected countertop in plan view. For information about these settings, see *Fill Style Panel and Dialogs on page 193*.

## **MATERIALS PANEL**

The settings on the MATERIALS panel affect the appearance of the selected countertop in 3D views. For information about these settings, see *Materials Panel on page 1055*.

## **LABEL PANEL**

Custom Countertop labels display in plan and cross section/elevation views when the "Polylines 3D, Labels" layer is turned on and use the Text Style assigned to that layer. The Automatic Label for countertops is blank, but you can specify a custom label. See *Cabinet Labels on page 630*.

For information about the settings on this panel, see *Label Panel on page 700*.

## **COMPONENTS PANEL**

The information on the COMPONENTS panel can be used in the materials list. For more information, see *Components Panel on page 1330*.



### **OBJECT INFORMATION PANEL**

The information entered on the OBJECT INFORMATION panel can be used in schedules and the materials list. See *Object Information Panel on page 1331*.

### **SCHEDULE PANEL**

The settings on the SCHEDULE panel determine which schedule categories the selected object is included in. See *Schedule Panel on page 704*.

# Electrical

# Chapter 18

The electrical plan shows the location of all electrical objects such as lights, switches, outlets, smoke detectors and vent fans. Basic wiring diagrams show which objects share circuits and the locations of the controlling switches.

Electrical objects can be displayed in 2D and 3D views. Some electrical light fixtures also add light sources to 3D and CPU Ray Trace views. See *Lighting on page 1135*.

Usually, the electrical plan is one of the last additions to a plan since the position of most electrical objects is determined by the location of walls, cabinets and other objects.

	Building requirements vary throughout the country and around the world. It is your responsibility to comply with local codes.
---	---

## TOPICS

<b>Electrical Defaults</b> .....	<b>667</b>
<b>The Electrical Tools</b> .....	<b>668</b>
<b>Placing Electrical Objects</b> .....	<b>670</b>
<b>Auto Place Outlets</b> .....	<b>671</b>
<b>Creating Wiring Schematics</b> .....	<b>671</b>
<b>Electrical Library Content</b> .....	<b>672</b>
<b>Displaying Electrical Objects</b> .....	<b>673</b>
<b>Editing Electrical Objects</b> .....	<b>674</b>
<b>Light Data Panel</b> .....	<b>675</b>
<b>Rope Light Specification Dialog</b> .....	<b>678</b>

## Electrical Defaults

 Default Settings for electrical objects control which symbols are placed in the current plan when the Electrical Tools are used. It can be accessed by selecting **Edit> Default Settings** or by double-clicking any of the electrical toolbar buttons, except **Rope Light** or **Connect Electrical**. See [Default Settings on page 77](#).

- [Electrical Defaults Dialog on page 667](#)
- [Rope Light Defaults on page 668](#)
- [Set as Default on page 668](#)

Default heights and other attributes of individual objects can be overridden in the Electrical Service Specification dialog. See [Light Data Panel on page 675](#).

### ELECTRICAL DEFAULTS DIALOG

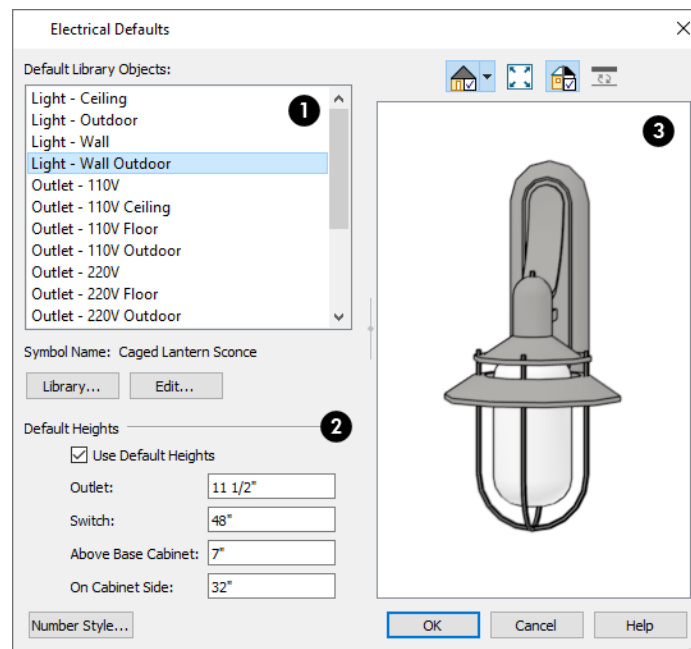

#### 1 Default Library Objects

The **Default Library Objects** are the objects created using the Electrical Tools. Select an item in the scrollable list to see and edit its settings.

- The name of the object shown in the preview image displays here.
- Select an item in the Default Library Objects list and click the **Library** button to select a new default object from the library. See [Select Library Object Dialog on page 974](#).
- Click the **Edit** button to open the specification dialog for the selected object. Any changes you make in the specification dialog are saved with the plan as long as the selected object is not replaced. See [Light Data Panel on page 675](#).

#### 2 Default Heights

Specify the heights at which electrical outlets and switches are initially placed when the Switch or any of the Outlet tools

are used.

- Check **Use Default Heights** to apply the default heights specified here to electrical objects placed in plan view using the Electrical Tools. When this is unchecked, electrical objects use the height saved with their symbol. See *Placing Library Objects on page 972*.
- **Outlet** - Specify the default height for outlets, as well as phone, cable and TV jacks.
- **Switch** - Specify the default height for switches, doorbells and thermostats.
- **Above Base Cabinet** - Specify the default height for switches and outlets placed above base cabinets in plan view, as measured from the countertop. See *Adjusting Electrical Object Heights on page 675*.
- **On Cabinet Side** - Specify the default height for switches and outlets placed on the sides of cabinet boxes, measured relative to the side of the cabinet in question. See *Placing Electrical Objects on page 670*.

### **3** Preview

A preview of the selected object displays here. See *Dialog Preview Panes on page 22*.

## ROPE LIGHT DEFAULTS

 Select **Edit> Default Settings**, then click the arrow beside “Electrical”. Select “Rope Light” and click the **Edit** button to open the Rope Light Defaults dialog. The settings in this dialog are also found in the Rope Light Specification dialog. See *Rope Light Specification Dialog on page 678*.

## SET AS DEFAULT

 The **Set as Default** edit tool can be used to modify the current plan’s Electrical Defaults and Rope Light Defaults. Select an electrical symbol and click the **Set as Default** edit button. See *Set as Default on page 79*.

The default electrical object that is updated depends on the type of electrical object selected as well as its placement. An Outlet, for example, might be 110V, 220V, or GFCI; interior or exterior; wall or floor mounted.

---

# The Electrical Tools

 Select **Build> Electrical** to access the Electrical Tools. Some electrical objects are designed to be inserted into walls, floors, ceilings or cabinets, although some can also be free-standing. With the exception of Rope Lights and Connect Electrical splines, they can be created with a single click in plan and camera views. See *Placing Electrical Objects on page 670*.

The Electrical Tools place objects according to the settings in the Electrical Defaults dialog. The default heights for Outlets and Switches that follow can also be specified. See *Electrical Defaults on page 667*.

Different outlet, switch, and light fixture symbols can be placed in different room types. To take advantage of the program’s capabilities, define room types properly before placing electrical objects. See *Room Types and Functions on page 415*.

Once created, outlets, switches, and lights can be selected and edited. See *Editing Electrical Objects on page 674*.

## OUTLETS

The outlet tools can place receptacles on walls, the floor, and on the sides of cabinets and soffits.

Select **Build> Electrical**, then choose:



**110V Outlet** to place 110 volt duplex outlets.



**GFCI Outlet** to place ground fault circuit interrupter outlets.



**220V Outlet** to place 220 volt outlets.

The type and height of an outlet will vary depending on where it is placed. For example:

- An outlet placed on a wall at the back of a base cabinet in plan view is positioned above the counter.
- An outlet placed on a wall at the back of a base cabinet containing a kitchen sink is placed at the standard 11 1/2" (300 mm) above the floor.
- An outlet placed on the side of a cabinet or soffit will be positioned 32" (800 mm) up from that object's bottom.
- An outlet placed outside the building or in an exterior area such as a deck or porch will be weatherproof.
- An outlet placed in the central area of a room in plan view will be positioned on the floor, with one exception: 110V Outlets placed in Garage or Slab rooms will be positioned on the ceiling.



In camera views, 110V Outlets can be placed on ceilings in any room type.

## LIGHT FIXTURES



Select **Build> Electrical> Light** to place light fixtures on walls, the ceiling, or on soffits. All light fixtures placed in a plan can also serve as light sources in most 3D and CPU Ray Trace views. To place a light fixture using the Light tool:

- Click near a wall or the side of a soffit to place a wall-mounted fixture at that location.
- Click away from a wall to place a ceiling mounted light.
- Click inside a soffit in plan view or on its bottom surface in a camera view to place a ceiling mounted light on the soffit's bottom surface.
- Click outside a room and away from a wall to place a path light.
- Some light symbols from the library can be mounted under wall cabinets, as well.

The rendering characteristics of individual lights that control how they appear in rendered and CPU Ray Trace views can be specified on the LIGHT DATA panel of the Electrical Service Specification dialog. See [Light Data Panel on page 675](#).

## ROPE LIGHTS



Select **Build> Electrical> Rope Light**, then click and drag to draw a rope light path with regularly-spaced light sources along its length. Rope Lights are a type of Molding Polyline so their rope profile can be customized. See [Rope Light Specification Dialog on page 678](#).

## SWITCHES



Select **Build> Electrical> Switch** to place electrical switches on walls or on the sides of cabinets or soffits. Like outlets, the height of switches is measured from the floor to the center of the object.

- A switch placed on the side of a cabinet or soffit will be positioned 32" (800 mm) up from that object's bottom.
- Switches placed outside the building or in an exterior area such as a deck or porch will be weatherproof.



If you connect two or more switches in a circuit, they update to 3-way or 4-way switches automatically.

Switches placed from the Electrical Library do not automatically update by default, but can be specified to do so. See [Light Data Panel on page 675](#).

## AUTO PLACE OUTLETS



Select **Build> Electrical> Auto Place Outlets** and click in a room tool to place outlets at regular intervals around the entire room. See [Auto Place Outlets on page 671](#).

## CONNECT ELECTRICAL



Select **Build> Electrical> Connect Electrical**, then click and drag to draw splines that snap to electrical switches, outlets, and lights to illustrate wiring circuits. See [Creating Wiring Schematics on page 671](#).

## LIGHTING AND ELECTRICAL LIBRARY CATALOGS



A selection of free-standing and ceiling-, wall- and cabinet-mounted light fixtures is available in the Library Browser at Chief Architect Core Catalogs> Architectural> Lighting.

Special use outlets, switches, jacks and numerous other electrical items can be found at Chief Architect Core Catalogs> Mechanical, Electrical, Plumbing> Electrical. See [Placing Library Objects on page 972](#).

---

# Placing Electrical Objects

Electrical switches, outlets, lights, and other symbols can be created with a single click in any view. They can also be placed from the Library. See [Click-to-Create on page 164](#).

When the Switch, Light, or an outlet tool is used, the type and height of the object that is created will vary depending on where it is placed. As you move your mouse pointer around the view, an object preview will display near the pointer whenever it is over a location where an object can be placed. Specific details for each tool are noted in [The Electrical Tools on page 668](#).

The electrical objects in the Library are typically designed for a specific use and can only be placed on a wall, on the floor, or on the ceiling. Some are instead free-standing and are designed to be placed on a table or the floor. See [Placing Library Objects on page 972](#).

Wall mounted outlets, switches, and Library symbols can also be placed on the sides of cabinets and soffits. They will snap to the outside of the cabinet box or to the outside of Side or Back Panels, but will ignore doors and drawers.

When a light fixture is created using any method, including copying and pasting, it will always be turned On. This is the case even if the default symbol is turned Off. See [Light Data Panel on page 675](#).

## ELECTRICAL OBJECT HEIGHTS

When a wall-mounted electrical object is placed in plan view using one of the Electrical Tools, its initial height off the floor is based on settings in the Electrical Defaults dialog. See [Electrical Defaults on page 667](#).

Wall mounted electrical symbols placed directly from the Library derive their initial heights from specification settings saved with each object. See [Light Data Panel on page 675](#).

Similarly, cabinet-mounted electrical objects are placed using height information set in either the Electrical Defaults dialog or the symbol's specification dialog. If the default height is higher or lower than the cabinet it's being placed on, the electrical object will be placed along the top or bottom edge of the cabinet box.

In 3D views, an electrical object placed on a wall in a 3D view will snap to its default height provided that the mouse pointer is near that height when you click. If you move the mouse pointer away from the default height, the object will be positioned wherever you click on the wall, regardless of the height at that point.

---

## Auto Place Outlets

 Select **Build> Electrical> Auto Place Outlets** and click in a room to place 110 volt outlets on the walls around the entire room, spaced so that no wall position is farther than six feet (1800 mm) from the nearest outlet. 110 or 220 volt outlets are also placed behind large appliances. In addition, a light is placed above each sink.

Outlets and sink lights are placed based on settings in the Electrical Defaults dialog. See [Electrical Defaults on page 667](#).

It is important that a room's Type be defined before **Auto Place Outlets** is used so that outlets are placed appropriately. For example, **GFCI Outlets**  (Ground Fault Circuit Interrupter) are placed over cabinets in Kitchen, and Bath rooms. See [Room Types and Functions on page 415](#).

**Auto Place Outlets** does not work in rooms assigned an exterior room type such as Deck. To place outlets in an exterior room, place them from the Electrical Library or use the **110V Outlet**  tool.

Railings and invisible walls are ignored by **Auto Place Outlets**. If it is used in a room defined by railings or invisible walls, outlets are automatically placed in any adjacent rooms on the other side of these wall types. See [Room Definition on page 413](#).

Once placed, any outlet can be moved, edited, or deleted. See [Editing Electrical Objects on page 674](#).

---

## Creating Wiring Schematics

Electrical schematics can be created in two ways. Using the **Connect Electrical**  tool is quick and easy, but if you need detailed schematics, you can create your own wiring diagrams using the CAD tools. See [CAD Objects on page 290](#).

### CONNECT ELECTRICAL

 In plan view, select **Build> Electrical> Connect Electrical**, then click and drag to draw splines that snap to electrical switches, outlets, and lights to illustrate wiring circuits. See [Splines on page 324](#).

You can also draw a Connect Electrical spline using a selected Switch, Outlet, or Light fixture's Connect Electrical edit handle. When you move your mouse pointer over this diamond-shaped edit handle, the Connect Electrical  icon will replace the default arrow and you can click and drag to draw a connection between the selected object and another electrical object.

To create a new circuit or add to an existing circuit, click on a switch, outlet, or light while the **Connect Electrical** tool is active, drag to the next object and release. You can also draw electrical circuits using the **Alternate**  continuous drawing mode. See [Alternate on page 207](#).

When a **Connect Electrical** spline is first drawn, it looks like an arc but actually consists of two segments that are defined by vertex points. When selected, its edit handles display at each of these vertices. If you click and drag one of these edit handles, the length, angle, and curvature of the spline will change but the other vertices will not move.

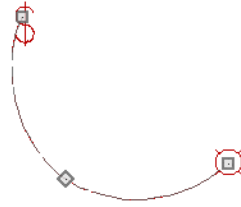

**Connect Electrical** splines cannot be snapped to one another: they can only snap to electrical objects. Once drawn, though, additional vertices can be added and used to form complex curves. See [Editing Spline-Based Objects on page 235](#).

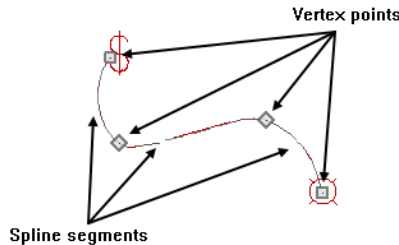

To remove a connection from a circuit, simply select and **Delete**  it. If you remove an electrical object from a circuit, any **Connect Electrical** splines snapped to it will also be deleted. See [Deleting Objects on page 284](#).

### THREE- AND FOUR-WAY SWITCHES

Multiple switches can control an object or group of objects.

- Two switches controlling the same objects are referred to as three-way switches.
- Three switches controlling the same objects are called four-way switches.

In plan view, a three- or four-way switch's "way" number will automatically display in its 2D symbol. You can prevent a switch's symbol from changing by unchecking **Automatically Change Switch Type When Wiring** in its specification dialog. See [Options Panel on page 994](#).

---

## Electrical Library Content

Select **View > Library Browser**  to access a variety of electrical symbols. See [The Library Browser on page 946](#).

Browse for electrical objects such as bath vent fans, an electrical panel, fluorescent lights, chandeliers, a smoke detector, thermostat, and more. Select a symbol, then click in your plan to place it on a wall, floor, or ceiling.

You can specify which electrical object in the library is used by each of the Electrical Tools. See [Electrical Defaults on page 667](#).

You can also assign electrical objects from the library to toolbar buttons for easy access and placement to frequently-used library objects. See [Place Library Object Button on page 975](#).

### ADDING ELECTRICAL CONTENT

Any electrical symbol placed into a plan can be customized and added to the User Catalog in the Library Browser. See [Add to Library on page 965](#).

You can also create electrical symbols and save them in the User Catalog. See [Symbol Objects on page 978](#).



---

## Displaying Electrical Objects



The display of electrical objects and connections is controlled in the Layer Display Options dialog. See [Layer Attributes on page 177](#).

When displayed in 3D views, light fixtures act as sources of light that help illuminate the 3D model. See [Lighting on page 1135](#).

### IN PLAN VIEW

In plan view, electrical objects are represented by commonly used CAD symbols that represent the type of object rather than its appearance in 3D. You can specify a different symbol for a selected electrical object in its Symbol Specification dialog if you wish. See [2D Block Panel on page 993](#).

Like other objects, electrical objects are placed in Drawing Groups that affect whether they display in front of or behind other objects in plan view. You can modify a selected object's place in the drawing order by clicking the **View Drawing Group Edit Tools**  edit button. See [Drawing Group Edit Tools on page 190](#).

By default, electrical symbols are placed on the “Electrical” layer. You can, however:

- Specify a different default layer for each type of object placed using the Electrical Tools by clicking the **Edit** button in the Electrical Defaults dialog. See [Electrical Defaults on page 667](#).
- Specify a different layer for an individual object after it has been placed. See [Layer Panel on page 186](#).

Connect Electrical splines are drawn on the “Electrical, Connections” layer by default. While the default layer for these objects cannot be changed, you can specify a different layer for a Connect Electrical spline after it has been drawn. See [Line Style Panel on page 305](#).

### ELECTRICAL LABELS

Electrical labels display in plan and cross section/elevation views when the “Electrical, Labels” layer is turned on and use the Text Style assigned to their layer. See [Label Panel on page 700](#).

Customized labels using text and Text Macros as well as label position and orientation can be specified in the Electrical Service Specification dialog. See [Text Macros on page 540](#).

Electrical objects can display callout labels as specified in the Electrical Schedule Specification dialog. See [Label Panel on page 700](#).

Electrical labels have their own edit handles and can be moved and rotated when the electrical object is selected.

Note: Some electrical objects are represented in plan view by a CAD block that includes text. This text is not part of the object's label and does not use the Text Style assigned to the “Electrical, Labels” layer.

### IN THE MATERIALS LIST

Electrical objects, including outlets, switches, lights, and symbols from the library such as jacks and fans, are listed under the Electrical Category in the Materials List. Connect Electrical splines are 2D objects only, however, and are not calculated. See [Materials Lists on page 1303](#).

As with other objects, there are a number of ways to control how, or whether, electrical objects are included in the Materials List. See *Organizing Materials Lists on page 1310*.

You can add and edit information about an electrical object's accessories and sub-accessories in specification dialog. See *Components Panel on page 1330*.

## ELECTRICAL SCHEDULES



The **Electrical Schedule** tool allows you to produce customizable electrical schedules as well as electrical labels that display schedule numbers. See *The Schedule Tools on page 682*.

To create an electrical legend, you can create an Electrical Schedule, customize it to include the 2D Symbol exclude most other columns. See *General Panel on page 692*.

---

## Editing Electrical Objects

Electrical objects can be selected individually as well as in a group in 2D and 3D views and edited using the edit handles, the Edit Toolbar and their specification dialog. See *Symbol Object Specification Dialogs on page 986*.

Electrical objects can be marquee-selected by type when the drawing tool used to create them is active. The Marquee Select Similar edit tool can also be used to group-select electrical objects. See *Selecting Multiple Objects on page 213*.

Light fixtures and Added Lights can be group-selected, but their light data cannot be edited unless each has the same number of light sources. See *Lighting on page 1135*.

Lights can also be edited using the Adjust Lights dialog. See *Adjust Lights Dialog on page 1140*.

## USING THE EDIT HANDLES

The edit handles for electrical objects vary depending on the location of the object.

- In plan view, Switches, Outlets, and Lights have a special diamond-shaped Connect Electrical edit handle located below the object's symbol. Click and drag this handle to draw a Connect Electrical spline between the selected object and another electrical object. See *Creating Wiring Schematics on page 671*.
- Wall mounted electrical objects cannot be rotated in plan view, so only the Move edit handle displays.
- Electrical objects placed on floors and ceilings can be rotated in plan view.
- In 3D views, some ceiling mounted and free-standing light fixtures can be resized.
- **Rope Lights** are edited like open polylines. See *Editing Open Polyline-Based Objects on page 224*.
- **Electrical connections** are edited like splines. See *Editing Spline-Based Objects on page 235*.
- When set to display in plan view, each electrical label has a small square Move edit handle and a small rectangular Rotate handle.
- In cross section/elevation views, an electrical label will also display on an electrical object's front when that side is visible and their label is set to display, and will have the same edit handles as in plan view.

## IN THE SPECIFICATION DIALOGS



Electrical objects can be edited in the Electrical Service Specification dialog. See *Symbol Object Specification Dialogs on page 986*.

**Rope Lights**  are a type of Molding Polyline with options for controlling the rope profile, light spacing, and more. See *Rope Light Specification Dialog on page 678*.

## USING THE EDIT TOOLS

A selected electrical symbol can be edited in a variety of ways using the buttons on the Edit Toolbar. See *The Edit Toolbar on page 130*.



**Change to GFCI Outlet** changes a selected 110V Outlet to a GFCI Outlet, as specified in the Electrical Defaults dialog.



**Change to 110V Outlet** changes a selected GFCI Outlet to a 110V Outlet.



**Turn Light(s) On in 3D** toggles a selected light on so that it emits light in 3D views while **Turn Light(s) Off in 3D** toggles it off. See *Displaying Lights on page 1138*.



**Edit CAD Block** allows you to edit the 2D CAD block associated with an electrical symbol. See *Edit CAD Block on page 330*.

## USING DIMENSIONS

Electrical objects can be moved precisely using dimensions. See *Moving Objects Using Dimensions on page 483*.

By default, electrical objects are not located by dimension lines as the lines are drawn. Once created, though, you can edit a dimension line's extensions to locate the center of any electrical object. See *Editing Extension Lines on page 478*.

In order to locate electrical objects by a dimension line as it is being drawn, first check the box beside **Electrical** on the LOCATE OBJECTS panel of the Dimension Defaults dialog. See *Locate Manual Panel on page 454*.

## ADJUSTING ELECTRICAL OBJECT HEIGHTS

When a wall- or cabinet-mounted electrical object is placed, its initial height is based on settings in the Electrical Defaults dialog. See *Placing Electrical Objects on page 670*.

Once placed, a wall-mounted electrical object's height can be edited in three ways:

- Specify the height in the Electrical Service Specification dialog. See *Symbol Object Specification Dialogs on page 986*.
- In 3D views, the position of an electrical object can be adjusted using its edit handles.
- In any view, use the **Transform/Replicate Object**  tool. See *Transform/Replicate Object Dialog on page 266*.

## DELETING ELECTRICAL OBJECTS

An electrical object can be deleted by selecting it and clicking the **Delete**  edit button or by pressing the Delete key.

All electrical objects in a room, on a floor, or in the entire plan can also be deleted as a group using the Delete Objects dialog. See *Deleting Objects on page 284*.

---

# Light Data Panel

 Electrical objects as well as Added Lights include the LIGHT DATA panel in their specification dialog. Select one or

more electrical objects and/or Added Lights and click the **Open Object** edit button to open the Electrical Service Specification, Added Light, or Light Data dialog.

The settings on this panel allow you to control the attributes of the light source(s) associated with the selected object. A number of the settings on this panel can also be edited in the Adjust Lights dialog. See *Adjust Lights Dialog on page 1140*.

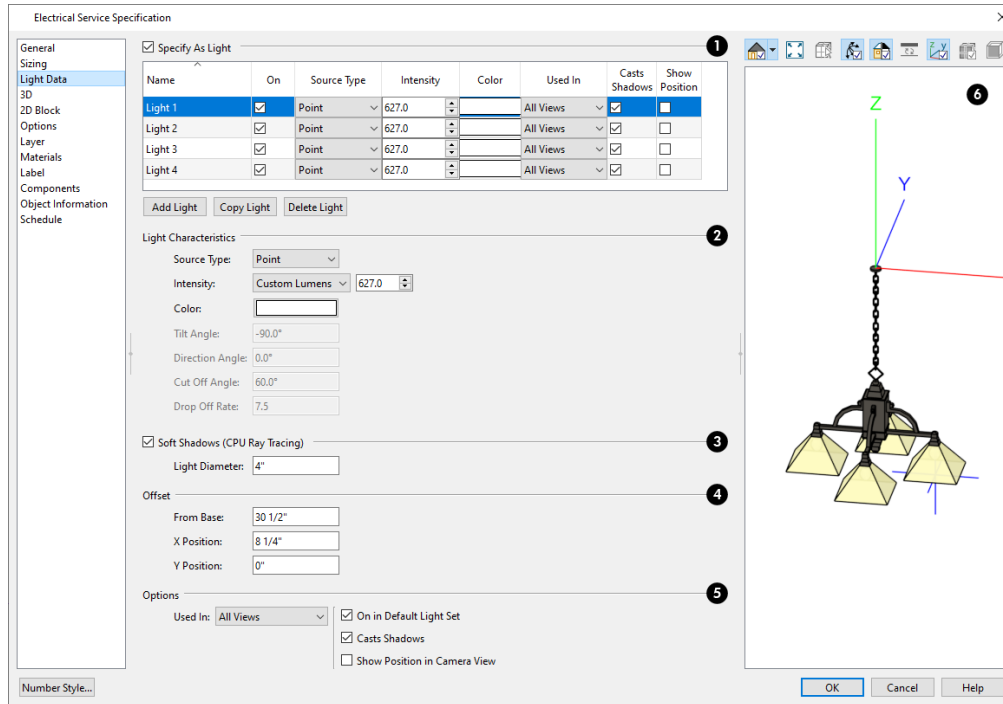

## 1 Light Sources

Each fixture can have multiple **Light Sources**, listed here. See *Lighting on page 1135*.

- When **Specify as Light** is checked, the selected electrical symbol can have light sources associated with it, and the settings below are enabled. Not available for Added Lights. See *Added Lights on page 1136*.
- Click on a line item in the table to select it for editing using either the settings in the table or those below. Multiple line items can also be selected and edited. See *Shift and Ctrl Select on page 214*.
- The selected light source's Position Indicator displays in the preview on the right.
- Click **Add Light**, **Copy Light**, or **Delete Light** to add or delete light sources from the list. If the selected fixture has only one light source, Delete Light will not be available. These options are not available for Added Lights.

## 2 Light Characteristics

- Select either **Point Light** or **Spot Light** as the light **Source Type**. The Type determines which options are enabled below. See *Light Types on page 1137*.
- Select an **Intensity** from the drop-down list. The available options are described using lumens and correspond to commonly used light bulb wattages. You can also use the text box or spin controls to make fine adjustments to the Intensity value. When a non-standard value is specified, the Intensity is described as “Custom Lumens”.
- Click the **Color** bar to define the color of the selected light source. Colored lights alter the appearance of textures and can be used to achieve special effects. See *Color Chooser/Select Color Dialog on page 203*.

 The default color of light is pure white, which has the least effect on the appearance of material colors and textures.

The Angle and Drop Off Rate settings below are only available for Spot Lights.

- The **Tilt Angle** controls the angle of the illumination with respect to the horizon. A value of -90° points the light straight down and a value of 90° points it straight up. 0° is parallel to the horizon.
- The **Direction Angle** defines the direction of the illumination relative to the ground. 0° is measured horizontally pointing to the right. Positive values rotate in a counter-clockwise direction from there. Enter a value up to 360°. If you enter a negative value, the program adds 360° to it when you click OK or press the Tab key.
- The **Cut Off Angle** controls the angle of the cone of illumination for Spot Lights only. A cone angle of 180° creates a spot light that shines in a half sphere on one side of the light source. A small cone angle, for example 10°, creates a very narrow cone of light.
- The **Drop Off Rate** affects how fast a Spot Light’s intensity drops off from the center of the cone to the outside edge.

A value of 0 produces a cone of light with the same intensity from the center to the outside edge and a sharp distinction between lit areas within the cone and unlit areas outside it. As this value is increased, the light intensity decreases closer to the edge of the cone and the distinction between lit and unlit areas becomes softer. Only available for Spot Lights.

### 3 Soft Shadows (CPU Ray Tracing)

Only available when the selected light source is a Point Light, these settings affect the selected light source in CPU Ray Trace views only. See [CPU Ray Tracing on page 1167](#).

- Check **Soft Shadows (CPU Ray Tracing)** to have the selected Point Light source cast shadows with soft edges in CPU Ray Trace views.
- Specify the **Light Diameter**, which is how big the source of illumination appears in CPU Ray Trace views.

### 4 Offset

The **Offset** settings control the location of the selected Light Source relative to the fixture.

- **From Base** controls how far the light source is from the fixture base. The fixture base is determined by the surface that it is attached to (i.e. wall, floor, or ceiling).
- **X Position** and **Y Position** allow you to position the light source relative to the center of the fixture, along the floor/ceiling.

### 5 Options

Additional **Options** that affect how the selected light source behaves are available.

- Select **Use in Camera View** to turn the selected light source on in regular 3D views only.
- Select **Use in CPU Ray Tracing** to turn the selected light source on in CPU Ray Trace views only.
- Select **Use in Both** to turn the selected light source on in both camera and CPU Ray Trace views.

Note: Some fixtures may have four or five lights for use in CPU Ray Trace views but only one in rendered views. See [3D Rendering on page 1131](#).

- When multiple lights are selected, and they are set to be used in different types of views, **No Change** will be available. Leave this option selected unless you want the lights to all be used in the same types of views.
- The **On** check box's label is followed by the name of a Light Set because each light source's On status is saved on a per Light Set basis rather than with the light. When this dialog is opened in plan view, the light's status in the Default Light Set will be used. If it is opened in a camera view, its status in the Light Set that is active that view will be used. See [Light Sets on page 1139](#).
- **Casts Shadows** controls whether or not the selected light source casts shadows in camera and CPU Ray Trace views. See [Shadows on page 1133](#).
- Check **Show Position in Camera View** to indicate the position of a selected Point or Spot Light source in the preview pane and in all 3D views aside from Hand Drawn Lines renderings when it is turned On. This tool can be used to determine if your light source is positioned correctly. See [In 3D Views on page 1139](#).

## 6 Preview

A preview of the selected object displays here. The selected light source's Position in Camera View displays in all views except Plan View. See [Dialog Preview Panes on page 22](#).

# Rope Light Specification Dialog

Select a Rope Light and click the **Open Object** edit button to open the Rope Light Specification dialog.

The settings in this dialog are also found in the Rope Light Defaults dialog. See [Electrical Defaults on page 667](#).

The Rope Light Specification dialog has the following panels:

## GENERAL PANEL

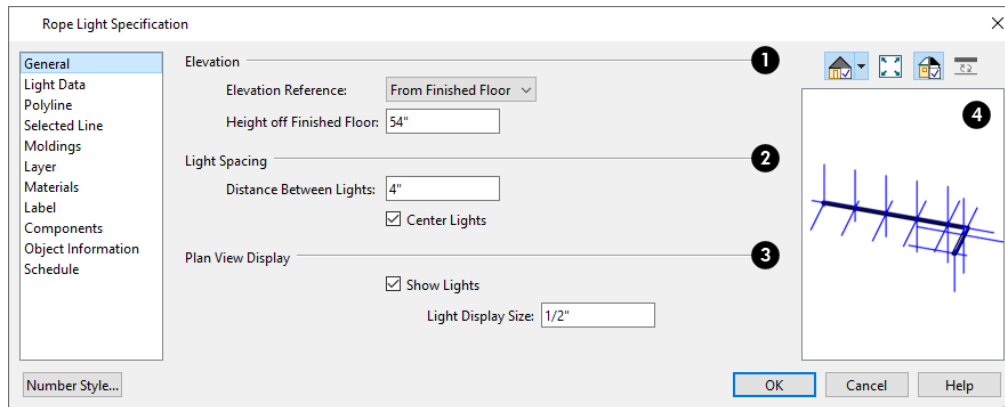

## 1 Elevation

- Select the **Elevation Reference** from the drop-down list. This determines where the next setting is measured from, and also affects its setting label.
- Specify the **Height** of the rope light, measured from the Elevation Reference to the top of the rope profile.

## 2 Light Spacing

- Specify the **Distance Between Lights**, measured from the centers of the light sources.
- When **Center Lights** is checked, the light sources are centered along the length of the rope light. Uncheck this to position a light source at the rope light's Start end and space additional lights along its length from there.

## 3 Plan View Display

- Check **Show Lights** to represent the light sources as circles inside the rope path. When unchecked, only the path is shown.
- Specify the **Light Display Size**, which is the diameter of the circles representing the light sources in plan view.

## 4 Preview

A preview of the selected rope light displays here. The selected light sources' Position in Camera View display in all views but Plan View. See *Dialog Preview Panes on page 22*.

### LIGHT DATA PANEL

The settings on the LIGHT DATA panel are also found on the same panel of the Electrical Service Specification dialog. See *Light Data Panel on page 675*.

### POLYLINE PANEL

The POLYLINE panel states the **Length** of an open polyline, and the **Perimeter** and **Area** of a closed polyline. See *Polyline Panel on page 317*.

### SELECTED LINE/ARC PANEL

The SELECTED LINE panel is available when the selected segment of the Rope Molding polyline is a line as opposed to an arc. See *Line Panel on page 304*.

The SELECTED ARC panel is available when the selected segment of the polyline has been converted into an arc. See *Arc Panel on page 312*.

See, too, *Selected Edge on page 212* and *Change Line/Arc on page 256*.

### MOLDINGS PANEL

The MOLDINGS panel is found in dialogs throughout the program. Here, its settings allow you to specify a rope profile. See *Moldings // Profiles / Rails / Panels on page 927*.

### LAYER PANEL

The LAYER panel is found in the specification dialogs for a variety of objects, including electrical objects. For more information, see *Layer Panel on page 186*.

### MATERIALS PANEL

The MATERIALS panel is found in the specification dialogs for a variety of objects. For more information, see *Materials Panel on page 1055*.

### **LABEL PANEL**

Labels for electrical fixtures display in plan view and cross section/elevation views when the “Electrical, Labels” layer is turned on and use the Text Style assigned to that layer. See *Electrical Labels on page 673*.

For information about the settings on this panel, see *Label Panel on page 700*.

### **COMPONENTS PANEL**

The information on the COMPONENTS panel can be used in the materials list. For more information, see *Components Panel on page 1330*.

### **OBJECT INFORMATION PANEL**

The information entered on the OBJECT INFORMATION panel can be used in Electrical Schedules and the materials list. See *Object Information Panel on page 1331*.

### **SCHEDULE PANEL**

The settings on the SCHEDULE panel determine which schedule categories the selected rope light is included in. See *Schedule Panel on page 704*.



# Schedules and Object Labels

## Chapter 19

A schedule is similar to a simple Text object with grid lines separating rows and columns, but are dynamically linked to objects in your plan and automatically update whenever an object is created, deleted, moved, or altered.

Schedules are available for doors, windows, cabinets, fixtures, framing objects, furniture, electrical items, plants, and the contents of rooms. You can also create custom schedules with a combination of these categories as well as create custom categories. Each schedule can contain information for one or all floors of your plan.

Schedules are highly customizable, so you should check each schedule that you create to be sure it presents the information that you want it to.

A variety of objects in Chief Architect have labels that display information about them in plan and cross section/elevation views. Some of those objects also have schedules associated with them and may display schedule callout labels.

### TOPICS

<b>Schedule Defaults</b> .....	<b>682</b>
<b>The Schedule Tools</b> .....	<b>682</b>
<b>Create Schedule from Room</b> .....	<b>683</b>
<b>Schedule Categories</b> .....	<b>684</b>
<b>Editing Schedules</b> .....	<b>685</b>
<b>Schedule Numbering</b> .....	<b>688</b>
<b>Columns to Include</b> .....	<b>689</b>
<b>Custom Object Fields</b> .....	<b>690</b>
<b>Find Object in Plan</b> .....	<b>691</b>
<b>Working with Multiple Schedules</b> .....	<b>691</b>
<b>Schedule Specification Dialog</b> .....	<b>692</b>
<b>Object Labels</b> .....	<b>699</b>
<b>Label Panel</b> .....	<b>700</b>
<b>Schedule Panel</b> .....	<b>704</b>

---

## Schedule Defaults

 The initial settings for each type of schedule can be set in its Schedule Defaults dialog. Access Default Settings by selecting **Edit> Default Settings**, then clicking the arrow beside "Schedules". Select a subheading and click the **Edit** button to open the Schedule Defaults dialog associated with your selection. Multiple defaults can be selected at once by holding down the Shift or Control key. See [Default Settings on page 77](#).

Schedule defaults can also be accessed by double-clicking the **Schedule Tools**  parent button or any of the child tools.

When a schedule is created, its initial characteristics are determined by the settings in the Schedule Defaults dialog for its schedule type. Default settings for callout schedule labels are also set here.

Each Schedule Defaults dialog looks the same as its corresponding Schedule Specification dialog. See [Schedule Specification Dialog on page 692](#).

---

## The Schedule Tools

Different types of schedules and tables can be created in plan and layout files for a variety of purposes.

All schedules present in a file are listed in the Project Browser. See [Project Browser on page 58](#).

### PLAN SCHEDULES

 In plan view, a cross section/elevation view, or a CAD Detail window, select **Tools> Schedules** to access the Schedule Tools. Select a Schedule Tool, then click in the view to place a schedule of the selected type at that location. You can continue clicking to place additional copies of the schedule if you wish. See [Click-to-Create on page 164](#).

While you can place schedules in plan view, you may find it helpful to place them in one or more CAD Detail windows instead. This allows you to send schedules to layout without including extra data or needing to resize the layout view box. See [CAD Details on page 337](#).

 [Cabinet Schedules on page 630](#)

 [Door Schedules on page 550](#)

 [Electrical Schedules on page 674](#)

 [Fixture and Furnishing Schedules on page 980](#)

 [Framing Schedules on page 882](#)

 [Fixture and Furnishing Schedules on page 980](#)

 [Notes, Note Types, and Note Schedules on page 533](#)

 [Plant Schedules on page 1295](#)

 [Room Finish Schedules on page 447](#)

 [Wall Schedules on page 366](#)



*Window Schedules on page 588*



*Custom Schedule Categories on page 684*

## ROOM SCHEDULES



Select a room and click the **Create Schedule from Room** edit button to create a schedule of that type showing only contents of the room. See *Create Schedule from Room on page 683*.

## CUSTOM SCHEDULE CATEGORIES



Select **Tools> Schedules> Manage Custom Categories** to create, rename, and delete custom schedule categories in the current plan file. See *Schedule Categories on page 684*.

## LAYOUT SCHEDULES

In addition to the Schedule Tools available in plan files, there are two that can be used in layout. See *Layout Page and Revision Tables on page 1361*.



Select **Tools> Layout> Layout Page Table**, then click to create a Layout Page Table.



Select **Tools> Layout> Layout Revision Schedule**, then click to create a Layout Revision Schedule.

---

# Create Schedule from Room



Select a room and click the **Create Schedule from Room** edit button to create a schedule showing only objects of a particular type in the room. You can also turn any schedule into a Room Schedule using the **Include Objects from Room** setting in the Schedule Specification dialog. See *General Panel on page 692*.

An object will be listed in a schedule if its center point is located inside the room. All objects associated with a Distribution Path or Region will be listed in a schedule if the center point of the path or region is located inside the room. If the center point of the path or region is not located in the room, none of its objects will be listed. See *Distributed Objects on page 1042*.

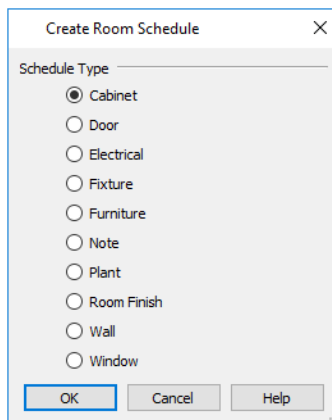

Select a **Schedule Type**, then click OK and click in the drawing area to create a schedule of the selected type that lists objects located in the room that you selected.

## Schedule Categories

Chief Architect has a set of system schedule categories that correspond to the types of objects that can be included in a schedule. Examples of these object types include:

- The object types created by the program’s Cabinet and Electrical Tools.
- The various Door and Window Types.
- Fixture and Furniture symbol Types.
- The various types of framing members.
- Millwork, Molding, and Roof Trim
- Wall Types
- Room Types
- Note Types
- CAD polylines
- Plants and Sprinklers each have a single system category.
- Architectural Blocks in legacy plans may be included in an “Other” category.

You can find a complete list of categories and specify which is included in a given schedule in its specification dialog. See [General Panel on page 692](#).

You can also assign any object that can be listed in a schedule to one or more of these categories. See [Schedule Panel on page 704](#).



### CUSTOM SCHEDULE CATEGORIES

When the system categories do not meet your needs, you can use Custom Schedule Categories to include an object or group of specific objects in the schedule(s) of your choice regardless of their actual object type. For example:

- To include a glass door along with windows in a glazing schedule.
- To include a dishwasher in a cabinet schedule.

To use a Custom Schedule Category, first create it; then assign one or more objects in your plan to that category; and finally, set one or more schedules to include that category.

#### *To create and use a custom category*

1. Select **Tools> Schedules> Manage Custom Schedule Categories** .
2. In the Manage Custom Schedule Categories dialog, click the **New** button and type a short, descriptive name for your new category.
3. Select an object that you would like to assign to your new custom category and click the **Open Object**  edit button.
4. On the SCHEDULE panel of the object’s specification dialog, under the **Categories to Include** heading, check the box to the left of the new category’s name. See [Schedule Panel on page 704](#).
5. Create a schedule and open its specification dialog. On the GENERAL panel, check the box to the left of the new category’s name. See [General Panel on page 692](#).

- When the custom category is for objects that insert into other objects, you may wish to specify a custom label in the containing object's specification dialog.

### MANAGE CUSTOM SCHEDULE CATEGORIES DIALOG

To open the Manage Custom Schedule Categories dialog, select **Tools > Schedules > Manage Custom Categories**. You can also access this dialog via **Default Settings** : click the "+" next to "Schedules" to display the schedule sub-headings, then select "Custom Schedule Categories" and click the **Edit** button.

## Editing Schedules

Schedules can be edited using the edit handles, the Edit Toolbar buttons, and the Schedule Specification dialog.

### USING THE EDIT HANDLES

A selected schedule has edit handles similar to those of a CAD box. See *Editing Box-Based Objects on page 232*.

In addition, schedules have edit handles that let you control the order of the rows and columns, as well as column width. Simple **Text**  objects with tabbed contents also have some of these handles:

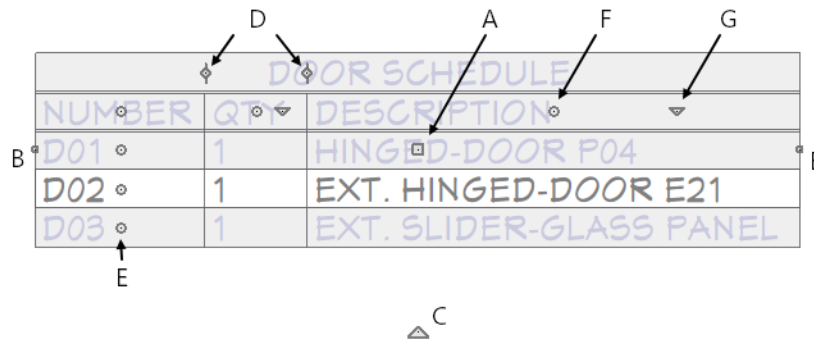

#### A. Move

- The **Move** handle is located at the center of the schedule. Click and drag this handle to change the schedule's position.

#### B. Resize

- The small circular **Resize** handles are located on the schedule's two vertical edges. Click and drag one of these handle to make the schedule wider or more narrow. The right-most column's width is affected by this change.

#### C. Rotate

- The triangular **Rotate** handle is located below the schedule. Click and drag this handle to rotate the schedule around its center point.

#### D. Resize Column

- The small circular **Resize Column** edit handles are located in the Title row, centered on the grid lines that divide the columns, and can be dragged left or right. If a column is resized sufficiently small, the text within will wrap to multiple rows.

### E. Move Row

- The small circular **Move Row** edit handles are located in the first column, centered in each cell. Drag one of these handles to move the row associated with it up or down in the schedule. See [Editing Schedule Order on page 688](#).

### F. Move Column

- **Move Column** edit handles are located in the Heading row, centered in each cell, and can be dragged left or right.

### G. Sort by Column

- The small triangular **Sort by Column** edit handles are located in the Heading row, right of center in each cell. Click this button to sort the entire schedule according to the contents of its column. Click again to reverse the sorting direction. You can also sort by column in the Schedule Specification dialog. See [General Panel on page 692](#) as well as [Schedule Numbering on page 688](#).

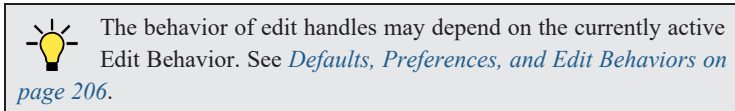

By default, the objects listed in the selected schedule are arranged in rows and information about them is presented in columns. You can **Swap Rows/Columns** to instead list objects in columns and information about those objects, in rows. See [General Panel on page 692](#).

## IN THE SPECIFICATION DIALOG

 The contents, Text Styles, and other attributes of schedules can be modified in the Schedule Specification dialog. See [Schedule Specification Dialog on page 692](#).

You can control how objects are listed in a schedule by specifying which Columns to Include. For example, if you were to include "Flower Color" but exclude "Common Names" and "Scientific Names" in the Schedule Specification dialog, the resulting plant schedule would list all red flowers in one line item, regardless of their species. See [Columns to Include on page 689](#).

You can also control the appearance of the callout labels associated with objects listed in a schedule. See [Object Labels on page 699](#).

## USING THE EDIT TOOLS

A schedule can be edited in a variety of ways using the buttons on the Edit Toolbar. See [The Edit Toolbar on page 130](#).

The **Align Left**, **Align Right** , **Center** , or **Justify**  edit tools allow you to specify how the contents of schedule columns are aligned. See [Aligning Text on page 513](#).

The **Spell Check**  edit tool checks the spelling of the selected schedule's title and column headers. Information about objects reported in the schedule body, however, is not checked. See [Spell Check on page 517](#).

## OPEN ROW OBJECT(S)

 Click the **Open Row Object(s)** edit button to open the specification dialog of the object or objects associated with the currently selected schedule row. See [Specification Dialogs on page 21](#).

Depending on the objects associated with the row, some settings may be reported as "No Change", and some may not be available to edit.

In some instances, this edit button may not be available: for example, if identical rooms on separate floors are associated with the same row of a Room Finish Schedule.

## CONVERTING SCHEDULES TO TEXT

 Click the **Schedule to Text** edit button to convert the selected schedule to a tabbed text object. You can then edit the schedule as text.

When a schedule is converted to text, it no longer updates automatically. In addition, shaped labels displaying as specified in the schedule's specification dialog will no longer be present.

 You can copy the text from the Text Specification dialog and paste it into other applications.

## EXPORT TEXT

 A selected schedule can be exported into one of several different file formats that can be opened by various programs. Select an individual schedule and click the **Export Text** edit button to open the Export Text dialog.

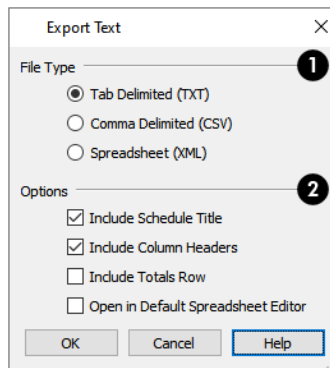

### 1 File Type

Specify the **File Type** that you would like to export to.

- Select **Tab Delimited (TXT)** to create a text file with a tab between each field entry in the Materials List, and a carriage return between each row.
- Select **Comma Delimited (CSV)** to create a text file with a comma between each field entry in the Materials List and a carriage return between each row.
- Select **Spreadsheet (XML)** to create a file that can be opened by Microsoft Excel.

### 2 Options

- Uncheck **Include Schedule Title** to prevent the schedule's Main Title from being exported.
- Uncheck **Include Column Headers** to prevent column headings from appearing in the first row of the exported file.
- Check **Include Totals Row** to export the "Totals" row from schedules that report door, window, or room finish information. See [Columns to Include on page 689](#).
- Check **Open in Default Spreadsheet Editor** to open the exported file with the default program specified on our computer for that file type when you finish exporting.

When you click OK, the Write Export File dialog will open. This is a typical File Save dialog. See [Exporting Files on page 41](#).

## Schedule Numbering

When an object is listed in a schedule, its Schedule Number can be shown either in the Number column, or the Callout Symbol column which also displays the callout label shape, if using. See [Columns to Include on page 689](#) and [Object Labels on page 699](#).

### DEFAULT SCHEDULE NUMBERING

By default, schedule numbering is dependent on the order in which objects are placed in the plan, as well as the floor they are on.

- Any objects present in your plan before a schedule is created will be listed first in ascending alphanumeric order, according to their Label information.
- Any new, unique objects placed in the plan after the schedule is created will be added to the bottom of the schedule in the order that they are placed, regardless of its Label information.

When an object is edited, its schedule number may or may not change:

- If an object with a Quantity of 1 in the schedule is edited, its position in the schedule will not change.
- If a group of objects listed on the same row in a schedule are edited simultaneously, their position will not change.
- If an object listed on the same row in a schedule with other similar objects is edited so that it is no longer similar enough to share the same row, it will move to the bottom of the schedule. See [Columns and Quantity on page 689](#).

### AUTOMATIC SORTING

An alternative to the default numbering behavior is Automatic Sorting. You can set all rows in a schedule to sort by a specific column regardless of the order in which the objects were created or their Label information. You can also choose whether to sort in ascending or descending order. See [General Panel on page 692](#).

If schedule order is manually edited, you will be prompted to turn off Automatic Sorting.

### EDITING SCHEDULE ORDER

If a schedule's order does not meet your needs, you can change it in either of two ways:

- Using the schedule's Move Row edit handles. See [Using the Edit Handles on page 685](#).
- Using an object's **Move Up in Schedule** and **Move Down in Schedule** edit tools.

When an item in a schedule is moved to a different row, its schedule Number will change, as will that of any other item whose position is affected by that move.



When a given object is included in only one schedule, its position in that schedule can be modified using the **Move Up in Schedule** and **Move Down in Schedule** edit tools. These edit tools are not available if the schedule has **Use Label** selected in its specification dialog. See [Labels Panel on page 697](#).

### RENUMBER SCHEDULE



To remove any gaps in numbering that might have been created when objects were edited or deleted, select the schedule and click the **Renumber Schedule** edit button.



## SCHEDULE NUMBER FORMAT

The numbering for each schedule begins with 1 by default, and schedule number formatting includes a leading zero along with an optional prefix. You can choose a different Prefix, Schedule Number Start, and omit the leading zero if you wish in the Schedule Specification dialog. See *Labels Panel on page 697*.

You can specify that an object's Schedule Number be included as part of its Automatic Label in its specification dialog. See *Label Panel on page 700*.

The Schedule Number can also be inserted into an object's Label or Object Information fields using the %schedule\_number% text macro. Alternatively, you can use the %simple\_schedule\_number% macro, which excludes the leading zero and prefix and simply reports the number. See *Text Macros on page 540*.

---

## Columns to Include

Every schedule has a selection of **Columns to Include** in its specification dialog. The columns that are available depend on the type of schedule selected. See *General Panel on page 692*.

Information in the **Code**, **Comment**, **Description**, **Manufacturer**, and **Supplier** columns is drawn from an object's specification dialog. See *Object Information Panel on page 1331*.

Schedules also have a selection of **Categories to Include**, as well. For example, you can specify whether to include Plumbing, Appliances, and HVAC in a Fixture Schedule. Categories can be used to create a variety of special purpose schedules. See *Working with Multiple Schedules on page 691*.

Note: Cabinet, Electrical, Fixture, and Furniture Schedules have an "Other" Objects to Include option that refers to architectural blocks set to be included in that schedule type. See *Architectural Block Specification Dialog on page 1010*.

## COLUMNS AND QUANTITY

It is important to remember that the columns you choose to include in a schedule can influence the number of separate line items that will be listed in the schedule.

For example, if you have three 30" wide doors and do not include the "Size" and "Description" columns, the three doors will be listed in the same line item - even if one is a hinged door, one a slider and one a pocket door.

If you prefer, you can uncheck **Group Similar Objects** in the Schedule Specification dialog to place every object in its own row, regardless of any shared attributes. See *General Panel on page 692*.

Note: The object preview columns do not affect whether or not objects are grouped in the same line.

## COLUMN AND ROW TOTALS

If a Door, Window, or Room Finish Schedule includes an Area column, an additional "Totals" row will display at the bottom of the schedule for total area calculations. Room Finish Schedules will also include a "Totals" row if multiple rooms included in the schedule have identical objects in them.

In addition, the "Total Length" column is available in schedules set to include wall types, moldings, or roof trim.

## OBJECT PREVIEWS

Aside from those for Rooms and Layouts, schedules have a selection of Columns that display object preview images.

With the exception of plant images, 3D object previews are drawn using plot lines. Each object preview inherits its line color, weight, and style from the object’s layer settings in the “Camera View Set” layer set. See [Layer Sets on page 182](#).

The 2D Symbol preview uses the settings for the layer set that is currently active in plan view. The 2D Symbol column is not available for Doors, Windows, or Cabinets.

## CUSTOM COLUMNS

In all schedules aside from Framing and Room Finish Schedules, there are two ways to create custom columns: by creating custom Sub Categories in the Preferences dialog and by creating Custom Fields. See [Custom Object Fields on page 690](#).

Custom Sub Categories are assigned to an object on the COMPONENTS panel of its specification dialog. To make an object in a custom Sub Category available for use in other plans, add it to the library. See [Adding Library Content on page 965](#).

Objects with Custom Fields can also be added to the library. In addition, Custom Fields are plan-specific and can be specified in many objects’ specification and defaults dialogs. See [Custom Object Fields on page 690](#).

Both Sub Categories and Custom Fields are listed as columns in the Schedule Specification dialog. See [General Panel on page 692](#).

---

# Custom Object Fields

Custom Object Fields allow you to create custom columns in schedules as well as specify the data that goes into those columns for each object.

Custom Fields can be assigned to a wide variety of objects in their specification dialogs. A value for each Custom Field can also be specified for individual objects, as well. See [Object Information Panel on page 1331](#).

## MANAGE CUSTOM FIELDS DIALOG

To open the Manage Custom Fields dialog, select **Edit > Default Settings**  and click the arrow next to “Schedules” to expand the category. Select “Custom Object Fields” and click the **Edit** button.

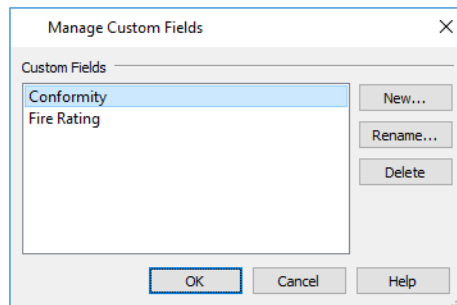

- A list of **Custom Fields** present in the current plan displays on the left. Click on the name of a field in the list to select it.
- Click the **New** button to open the Add New Field dialog, type a short descriptive name, and create a new Custom Field
- Click the **Rename** button to rename the selected Custom Field.

- Click the **Delete** button to delete the selected Custom Field from the current plan. A Custom Field can be deleted from a plan even if it is assigned to an object and included as a schedule column.

## Find Object in Plan

 To find out where a line item in a schedule or the Materials List is located in the model, select its row or any cell in its row and click the **Find Object in Plan** edit button. This tool opens a view window and selects the object or objects associated with that line item.

If a plan view showing the floor that the object is on is open, that view will become active and the object will be selected. If no such view is open, a new unsaved view showing the object's floor will be created. See [View Windows on page 144](#).

When a wall framing object is selected in a Framing Schedule, the Wall Detail of its parent wall will open instead. See [In Wall Detail Views on page 880](#).

If the selected item is a component of a complex object like an Auto Dormer, Muller Unit, Bay Window, or Architectural Block, the parent object will be selected in the plan instead of the individual component.

If the selected row or rows in a Materials List refer to objects on different floors, the Details dialog will open when you click the **Find Object in Plan**  edit button. See [Details Dialog on page 1312](#).

### SELECT LOCATION DIALOG

The Select Location dialog will open if you click the **Find Object in Plan**  edit button when the selected line item in a Materials List or the selected row in a schedule refers to objects located on more than one floor.

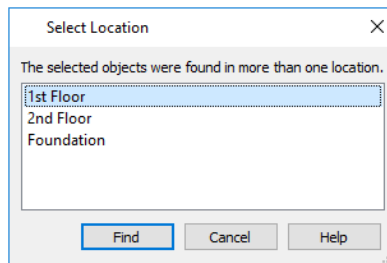

Select a floor in the list and click the **Find** button or double-click on a floor in the list to open a plan view window showing the objects on the selected floor.

## Working with Multiple Schedules

You can create multiple versions of any type of schedule for a variety of purposes. For example:



- Multiple Fixture Schedules can be set up for use as Plumbing, Appliance or HVAC schedules.
- Separate Electrical Schedules can be created for light fixtures and other electrical items.
- Separate Cabinet Schedules can be set up for each floor of a plan, or even for individual rooms.
- Special Door or Window Schedules can be prepared for Energy Ratings, Fire Doors or other information.

You can also specify that any object be listed in multiple schedule categories, as well as create custom schedules that list multiple types of objects. See [Custom Schedule Categories on page 684](#).

If you intend to use schedule callout labels, it is best to avoid including a given object in more than one schedule. If you choose to do so, the object will display a separate callout label for each schedule it is included in.

If you create multiple schedules of the same type, bear in mind that it is possible for different objects in those schedules to be assigned the same callout number. To avoid this, consider specifying different callout prefixes and/or callout shapes.

## Schedule Specification Dialog

 Schedules and the object labels associated with them can be edited in the Schedule Specification dialog. To open this dialog, either select a schedule and click the **Open Object** edit button or double-click the schedule using the **Select Objects**  tool.

The Schedule Specification dialog is similar to the specification dialogs for layout tables. See [Layout Page and Revision Tables on page 1361](#).

The options in these dialogs are also similar to those found in their corresponding Schedule Defaults dialogs.

The Schedule Specification dialog has the following panels:

### GENERAL PANEL

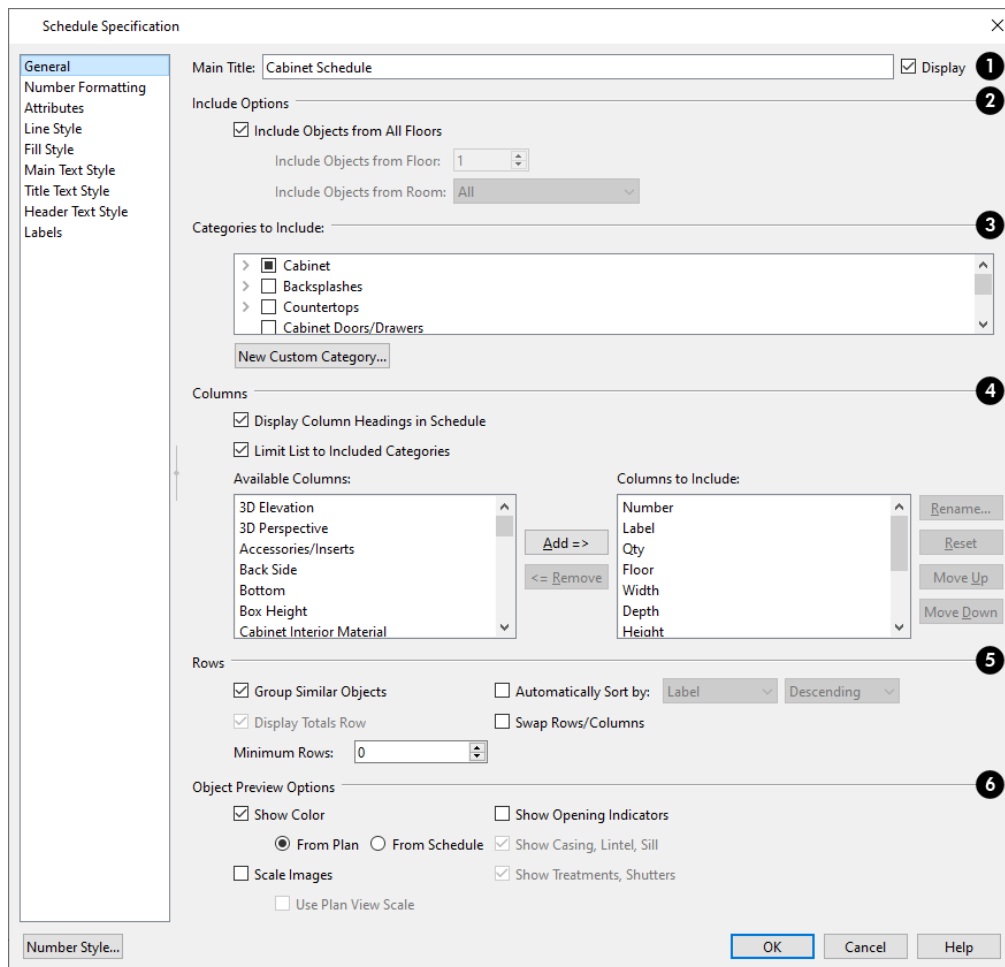

## 1 Main Title

- Specify a **Main Title** for the selected schedule.
- Check **Display** to include the Main Title at the top of the schedule.

## 2 Include Options

- To create a schedule of objects on a single floor, uncheck **Include Objects from All Floors** and then specify the floor. When this box is checked, objects from all floors are included. Not available in the Layout Table Specification dialog.
- If **Include Objects on All Floors** is unchecked in the Schedule Defaults dialog, each schedule will include objects on the floor that it is created on by default.
- When Include Objects from All Floors is unchecked, you can further limit the schedule to an individual room on the specified floor. Select that room from the **Include Objects from Room** drop-down list. See *Create Schedule from Room on page 683*.
- When a Framing Schedule is placed in a Wall Detail or Truss Detail, the **Only Include Objects from this Detail** check box is available. Uncheck this to include objects from throughout the plan. When checked, only objects present in the current view are listed.

## 3 Categories to Include

Check the box beside each type of object you want to include in the selected schedule. See *Schedule Categories on page 684*.

- Custom Note Types, Room Types, and Wall Types will be listed here, under their respective headings. By default, Room and Wall Schedules include newly created Room and Wall Types automatically, while Note Schedules do not.
- Click the **New Custom Category** button to new custom schedule category. See *Custom Schedule Categories on page 684*.

 You can create multiple unique schedules using Categories and Columns to Include as filters. See *Working with Multiple Schedules on page 691*.

## 4 Columns

Specify which columns are included in the selected schedule. See *Columns to Include on page 689*.

- Uncheck **Display Column Headings** to hide the selected schedule's Heading row. When this is checked, each column has a heading at the top.
- An alphabetical list of **Available Columns** displays on the left.
- When **Limit List to Included Categories** is checked, the Available Columns will only list the columns that are available for the Categories selected above. Uncheck this box to list the columns available for all Categories. See *Columns to Include on page 689*.
- Select one or more names in the list of **Available Columns**, then click the **Add** button to add them to the Columns to Include list on the right. See *Shift and Ctrl Select on page 214*.
- You can also double-click on an item in the list to add it to the Columns to Include list on the right.

- A list of the **Columns to Include** in the selected schedule displays on the right. The top-to bottom order in this list corresponds to the columns' left-to-right order in the schedule. At least one column must be included to create a schedule.
- Select or double-click on an item in the list and click the **Rename** button to specify a new name.
- Click the **Reset** button to restore the default names for all Columns to Include in the current schedule.
- Select one or more items in the list, then click the **Remove** button to remove those items from the list.
- Select one item in the list and click the **Move Up** button to adjust its position upward in the list.
- Select one item in the list and click the **Move Down** button to adjust its position downward in the list.

## 5 Rows

Not all of these options are available for layout tables. See *Layout Page and Revision Tables on page 1361*.

- Uncheck **Group Similar Objects** to list all objects in their own row, even when they share all attributes. When this is checked, objects that share the same attributes are counted in a single row. See *Columns and Quantity on page 689*.
- Uncheck **Display Totals Row** to suppress the bottom row stating the total area for all objects in the selected schedule. Only available in schedules set to include Door, Window, or Room categories, and only when one or more "Area" columns are included.
- Specify the **Minimum Rows** that the selected schedule displays, regardless of its actual content. If there are fewer line items in the schedule, blank rows will be added. This count does not include the Totals Row, if using.
- When **Automatically Sort by** is unchecked, the selected schedule's rows are sorted by their Label information in ascending order along with the order objects were placed in the plan. Check this box to sort all rows by a different column, choose that column from the drop-down list, and select whether to sort in Descending or Ascending order. Changing the column that a schedule is sorted by usually causes line items to be assigned different a Schedule Number. See *Schedule Numbering on page 688*.
- When **Swap Rows/Columns** is checked, the objects listed in the selected schedule are arranged in rows and information about them is presented in columns. Uncheck this box to instead list objects in columns and information about those objects, in rows.

## 6 Object Preview Options

These options affect the appearance of previews in the 2D Symbol, 3D Elevation, and 3D Perspective Columns, when included in the schedule. Not available for layout tables. See *Object Previews on page 690*.

- Check **Show Color** to draw Callout Symbol, 2D Symbol, 3D Elevation, and 3D Perspective object previews using colored lines. When this is unchecked, lines are black and 3D plant previews are shown in grayscale.
- Select **From Plan** to draw Callout Symbols and 2D Symbols using the color assigned to each object, and 3D Elevations and 3D Perspectives using black.
- Select **From Schedule** to draw Callout Symbol, 2D Symbol, 3D Elevation, and 3D Perspective object previews using the color assigned to the schedule.
- Check **Scale Images** to display object previews at the same relative scale. When unchecked, each preview fills its cell to the extent possible.
- In Electrical, Fixture, Furniture, Note, Plant, and Wall Schedules, check **Use Plan View Scale** to apply the same scale used in plan view to the 2D Symbol column.

- Check **Show Opening Indicators** to show opening indicator symbols in 3D Elevation previews for doors, windows, and cabinets. Only available in schedules set to include Door, Window, and/or Cabinet categories.
- Check **Show Casing, Lintel, Sill** to include these items in 3D Elevations and 3D Perspectives for doors and windows. Only available in schedules set to include Door and/or Window categories.
- Check **Show Treatments, Shutters** to include these items in 3D Elevations and 3D Perspectives for doors and windows. Only available in schedules set to include Door and/or Window categories.

## NUMBER FORMATTING PANEL

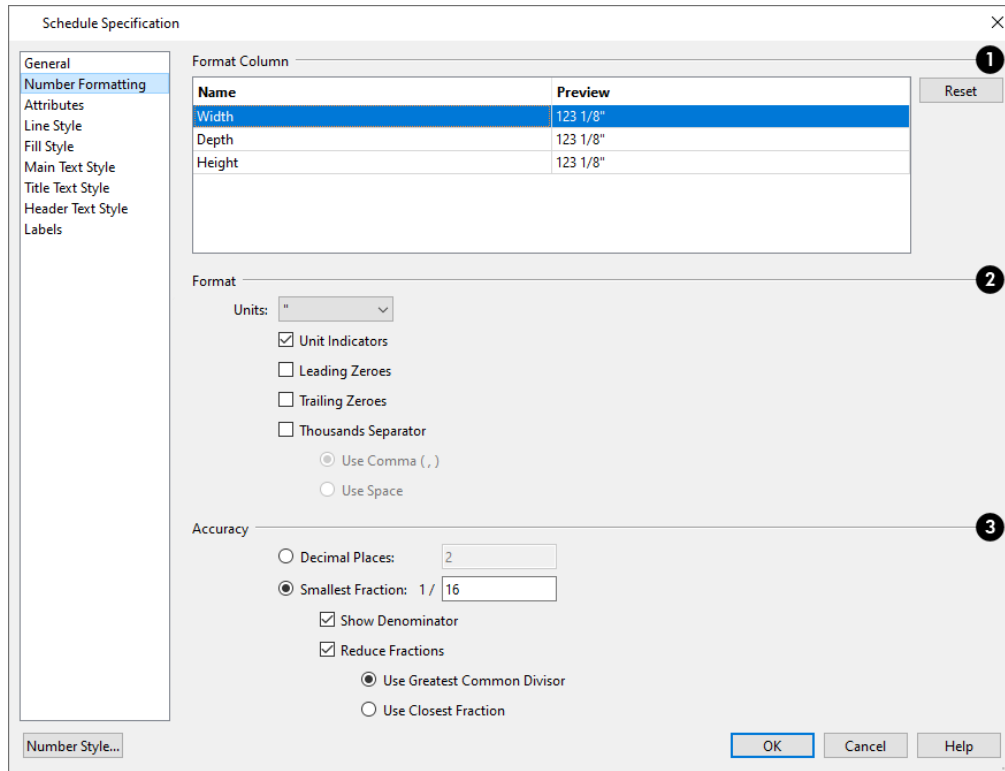

### 1 Format Column

The Names of the selected schedule's columns that use formatted numbers as opposed to text are listed in a table, along with a Preview of its number formatting. When multiple schedules with different columns are selected, the information associated with the schedule selected first will display here, but may not be editable.

- Click in a row to select it and edit its format using the settings below.
- Click the **Reset** button to reset all columns to the default format.

### 2 Format

- Select the **Units** of measurement to be used by the selected column(s) from the drop-down list. The choices in this list correspond to all units measuring length specified in the Preferences dialog. See [Unit Conversions Panel on page 109](#).
- Check **Unit Indicators** to display the unit of measurement in the selected column(s).

- Check **Leading Zeros** to include the zero before a decimal less than 1 or to display 0' or 0" when the ft-in or '-'' unit format is used.
- Check **Trailing Zeros** to display trailing zeros at the end of decimal values. When the ft-in or '-'' unit format is used and fractional inches are specified, 0" will be included.
  - Check **Thousands Separator** to use a digit grouping symbol for values greater than 999.
- Select the **Use Comma**, **Use Dot**, or **Use Non-Breaking Space** radio button to specify the thousands separator used in the selected column(s). Which option is available will depend on your operating system settings. See [Region and Language Settings on page 78](#).
- Select the **Use Space** radio button to use a space as the thousands separator.

### 3 Accuracy

- Select the **Decimal Places** radio button for values in decimal format. In the text field, specify the number of decimal places to use, from 0 to 20. If 0 is used, no decimal places are used.
- Select the **Smallest Fraction** radio button for values using whole numbers and fractions. In the text field, specify the largest denominator to use, from 1 to 128. If 1 is entered, whole numbers are used.
- Uncheck **Show Denominator** to turn off the display of fraction denominators used by dimension lines. Typically, denominators are only turned off when eighths are desired.
- Uncheck **Reduce Fractions** to always use the denominator specified above. When checked, the lowest possible denominator will be used. When Smallest Fraction is selected, specify how fractions are reduced:
  - Select **Use Greatest Common Divisor** to reduce fractions using the largest value that divides equally into the numerator and the denominator specified above. This option is best for fractional inches.
  - Select **Use Closest Fraction** to reduce fractions without referring to the denominator specified above. For example, a value of 0.333 is represented by the fraction 5/16 when Greatest Common Divisor is used and the Smallest Fraction denominator is 16. When Closest Fraction is selected, this value is represented by 1/3.

## ATTRIBUTES PANEL

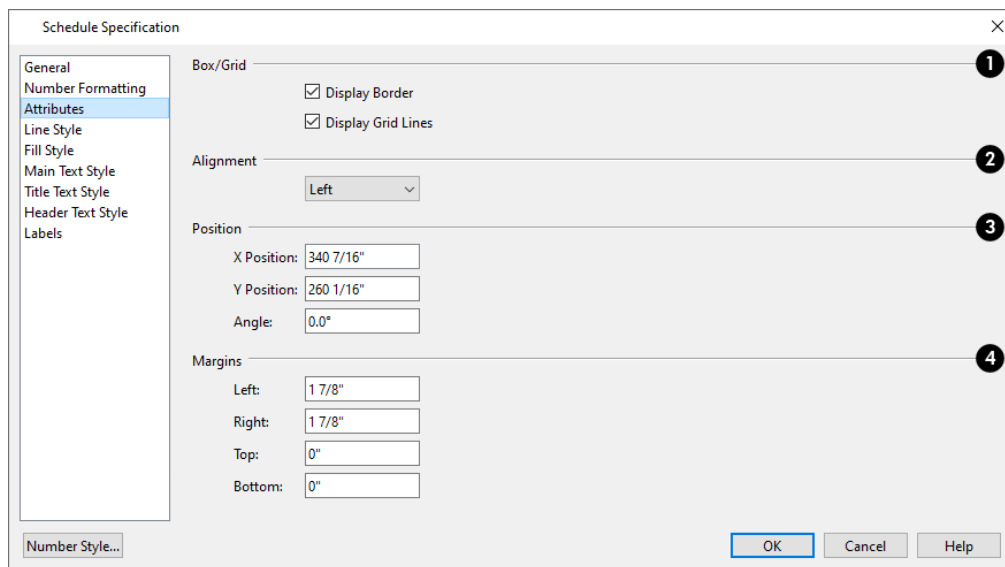



## 1 Box/Grid

Specify the appearance of the selected schedule's border and grid.

- Check **Display Border** to display lines around the outside of the schedule.
- Check **Display Grid Lines** to display lines around the rows and columns of schedule, forming boxes around each item, or cell.

## 2 Alignment

Specify the selected schedule's text alignment within its columns by choosing an option from the drop-down list.

## 3 Position

Define the position of the selected schedule. Not available in the Schedule Defaults dialogs.

- Specify the **X and Y Positions** of the schedule's center point.
- Specify the schedule's **Angle**.

## 4 Margins

Specify the **Left, Right, Top, and Bottom Margins**, which define the distance between the text and border of each schedule cell.

## LINE STYLE PANEL

The LINE STYLE panel is found in the specification dialogs for many different objects. For information about the settings on this panel, see *Line Style Panel on page 305*.

## FILL STYLE PANEL

The FILL STYLE panel is found in the specification dialogs for many different objects. For information about the settings on this panel, see *Fill Style Panel and Dialogs on page 193*.

## TEXT STYLE PANELS

The Schedule Specification dialog has three Text Style panels with settings that control the appearance of the selected schedule's text:

- MAIN TEXT STYLE controls the text style used in the body of the schedule
- TITLE TEXT STYLE controls the text style used in the schedule's title
- HEADER TEXT STYLE controls the text style used in the schedule's column headers.

For information about the settings on these panels, see *Text Style Panel on page 538*.

## LABELS PANEL

The LABELS panel of the Schedule Specification dialog controls the type, size and appearance of the labels that display in plan view.

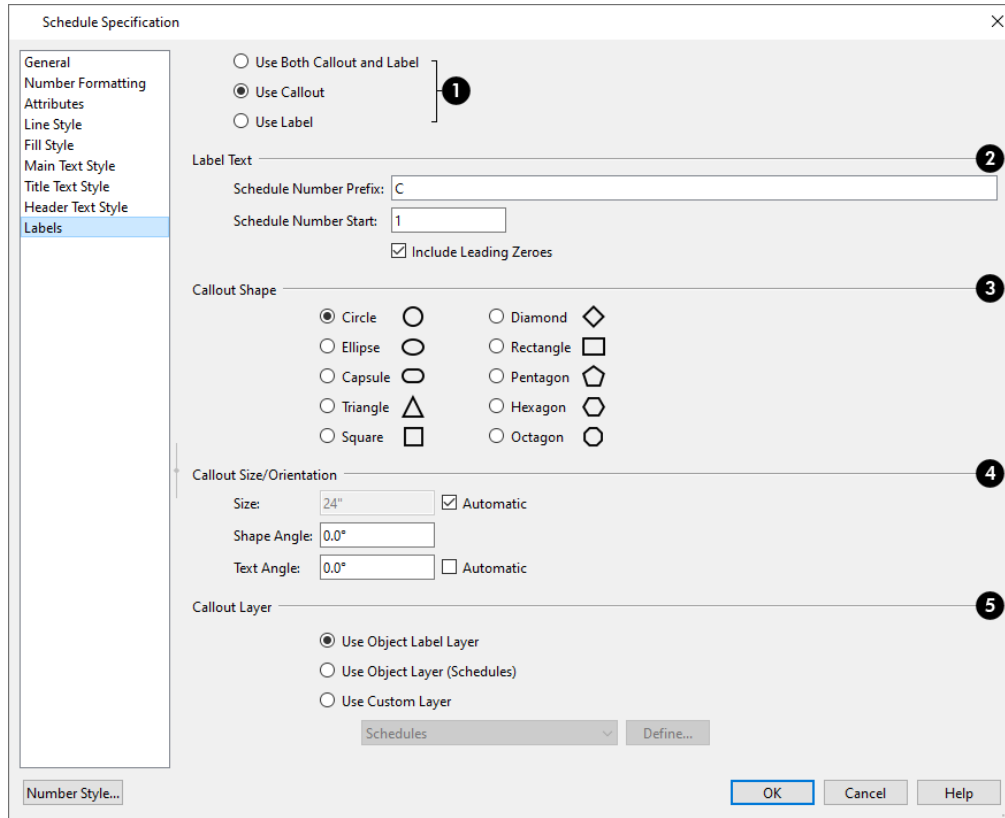

**1**

Specify which type(s) of label objects in the selected schedule use.

- Select **Use Both Callout and Label** for objects listed in the schedule to display both regular labels and schedule callouts.
- Select **Use Callout** for objects to display schedule callouts but not their regular labels.
- Select **Use Label** for objects to display only their regular labels and no callouts. See *Label Panel on page 700*.

**2** Label Text

- **Schedule Number Prefix** - Specify the leading characters used in callout labels or when Include Schedule Number is checked in the object's specification dialog. See *Label Panel on page 700*.
- Schedule labels usually start with the number 1, but you can select a different **Schedule Start Number** if you wish.
- When **Include Leading Zeroes** is checked, single-digit callout labels include a zero in front of the callout number. Uncheck this box to remove these leading zeroes from the labels.

**3** Callout Shape

When either **Use Both Callout and Label** or **Use Callout** is selected above, the callout shape can be selected here. There are ten shapes to choose from.

#### 4 Size/Orientation

- Uncheck **Automatic** to enable the **Size** field and specify a new value. When checked, the callout is sized so that it encompasses the Label Text that displays inside its shape.
- Specify the **Shape Angle**.
- Specify the **Text Angle** relative to the orientation of the callout shape. Not available when Ellipse, Capsule, or Rectangle is selected as the Callout Shape.
- When **Automatic** is checked, the Text Angle automatically matches the Shape Angle.

#### 5 Callout Layer

Specify the layer that the callouts associated with the selected schedule are placed on. See *Layers on page 176*.

- Select **Use Object Label Layer** to place each callout on the layer specified for that object's label.
- Select **Use Object Layer** to place the object's label on the same layer as the selected schedule. The name of this layer is reported here in parentheses for reference.
- Select **Use Custom Layer** to select any layer saved in the current file from the drop-down list.
- When Use Custom Layer is selected, you can click the **Define** button to open the Layer Display Options dialog and select, modify, or add a new layer. See *Layer Display Options Dialog on page 179*.

Like other object labels, callout labels use the Text Style assigned to the layer they are on. See *Text Styles on page 538*.

---

## Object Labels

Object labels can display in plan and cross section/elevation views for a variety of different object types using one of several formats:

- Automatic Labels provide basic information about the object, such as its type, size, or name.
- You can create a custom label for an object in its specification dialog using text and/or Text Macros. See *Label Panel on page 700*.
- Objects associated with a schedule can display a shaped callout label with each object's schedule number instead of or in addition to their regular object label. See *Schedule Specification Dialog on page 692*.

Object labels have their own edit handles that display when their object is selected, and can be both moved and rotated using edit handles as well as settings in the object's specification dialog. Schedule callout labels can be moved in the same manner but can only be rotated using settings in the Schedule Specification dialog. When an object has both label types displaying, they share a single Move handle and can only be rotated using settings in the object specification dialog and Schedule Specification dialog. See and *Labels Panel on page 697* and *Edit Handles on page 23*.

### AUTOMATIC LABELS

Most objects that can display labels have an Automatic Label created by the program that states basic information about it.

- Native objects such as doors, windows, and cabinets dynamically derive their automatic label from their size and type. See *Native Objects vs Symbols on page 971*.
- Symbol objects such as fixtures and furnishings derive their automatic label from the **Symbol Name** specified in the Symbol Specification dialog. See *3D Panel on page 990*.

When **Automatic Label** is selected in the object's specification dialog, this is usually the label that will be used; however:

- If a user-defined label is specified in the object's defaults dialog, that label will be used instead of the Automatic Label.
- If the object is included in a schedule and callout labels are specified in that schedule, a callout label will be used.
- Fixtures and appliances inserted into cabinets do not have labels of their own unless they are associated with a schedule set to use shaped callout labels.

## DEFAULT LABEL FORMATTING

Custom labels can include a variety of macros that report size information about the object. This information can be reported in either of two ways:

- Default Formatting includes the unit of measurement after each macro reporting size information. In files using US Units, sizes are described using fractional inches with up to 1/16" accuracy.
- When Default Formatting is not used, units of measurement are not shown and decimal inches are used.

You can specify whether to **Use Default Formatting** in the object's specification dialog. See [Label Panel on page 700](#).

## DISPLAYING LABELS



The display of object labels in plan and cross section/elevation views can be controlled by layer in the Layer Display Options dialog. System Default label layer names begin with the object type, followed by the word Label: for example, cabinet labels are located on the "Cabinets, Labels" layer. See [Layer Display Options Dialog on page 179](#).

You can choose to place an object's label on a different layer if you wish, as well as suppress the label for an individual object on the LABEL panel of its specification dialog. This setting does not affect schedule callouts. See [Label Panel on page 700](#).

Object labels use the Text Style assigned to each label's layer. For example, cabinet labels are placed on the "Cabinets, Labels" layer by default and use the Text Style assigned to that layer. The callouts associated with a schedule also use the Text Style associated with the layer they are placed on. See [Text Styles on page 538](#).

With the exception of those for rooms, roofs, and cameras, labels can also be included in the Materials List and Master List. Items in the Labels column of the Materials List are editable; however, any changes will not be applied to the actual objects' labels. See [Materials List Columns on page 1317](#).

The minimum on-screen display size of labels can be specified in the Preferences dialog. See [Appearance Panel on page 95](#).

---

## Label Panel



The LABEL panel is found in the specification and defaults dialogs for a variety of different objects. The settings that are available will vary depending on the type of object that is selected.

Note: If you choose a callout shape in the Schedule Specification dialog, the settings here are overridden and the schedule label is used instead. See [Labels Panel on page 697](#).

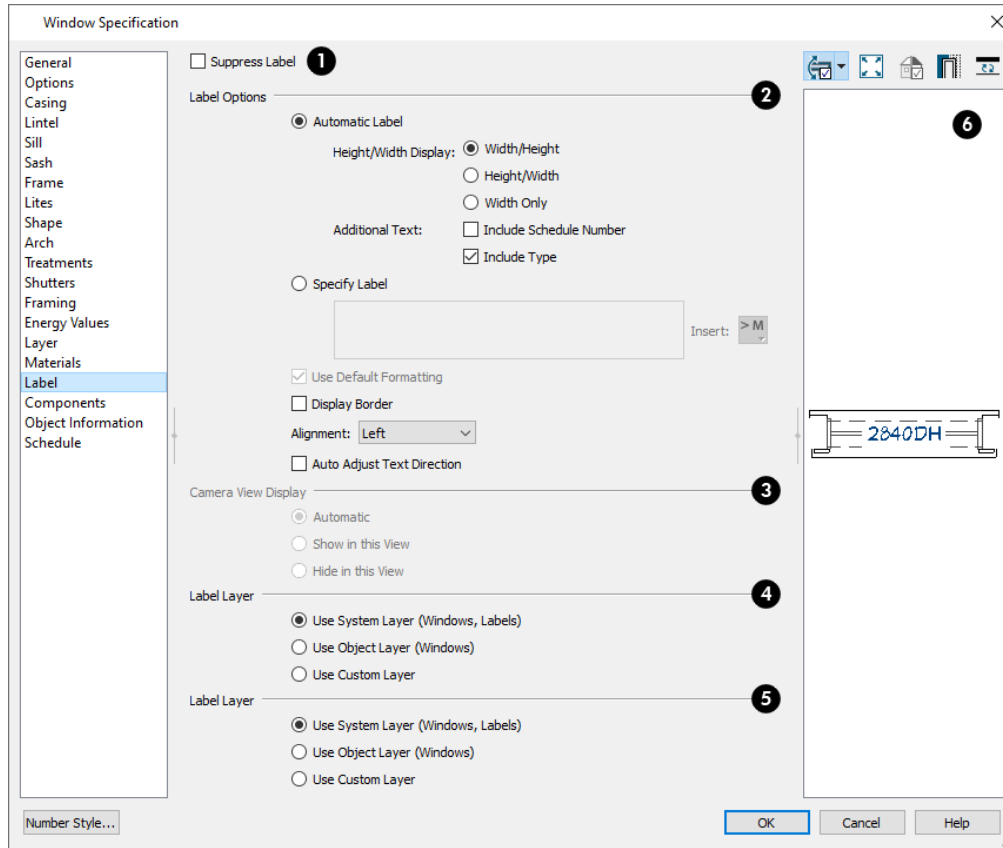

## 1 Suppress Label

Check this box to prevent the selected object’s label from displaying in plan and cross section-elevation views. This option does not affect the display of schedule callouts. See [Object Labels on page 699](#).

Most objects have this option; however, CAD blocks; Bay, Box, and Bow Windows; and Mulled Units instead have several settings for controlling **Multiple Component** labels. These settings also affect how Bay, Box and Bow Windows and Mulled Window units are counted in schedules and the Materials List. See [Window Labels on page 587](#) and [Displaying Mulled Units on page 584](#).

For CAD blocks; Bay, Box and Bow Windows; and Mulled Window units:

- Select **Suppress All Labels** to display no label in plan view. Individual components are counted in schedules and in the Materials List.
- Select **Show Component Labels** to produce labels for each component in plan view. Individual components are counted in schedules and in the Materials List.
- Select **Show Single Label for Entire Unit** to produce one label for the unit and suppress component labels. When this option is selected, the settings that follow on the LABEL panel become enabled.

## 2 Label Options

Specify the information reported in the label. Not available for cameras. See [Displaying 3D Views on page 1097](#).

- Select **Automatic Labels** to use the default label for the selected object. See [Automatic Labels on page 699](#).

The **Height/Width Display** settings are only available for doors and windows.

- Select **Width/Height** to use a numeric format in which the width in inches (mm) is followed by the height.
- Select **Height/Width** to use a numeric format in which the height in inches (mm) is followed by the width.
- Select **Width Only** to use a numeric format in which only the width in inches (mm) is indicated.

The **Additional Text** options add extra information to the Automatic Label as well as any schedules that the selected object is listed in. See [Columns to Include on page 689](#).

- Check **Include Schedule Number** to include the object's Schedule Number at the beginning of its Automatic Label text, as well as in the Label and Size columns of any schedule that it is listed in. See [Schedule Number Format on page 689](#).
- For a selected window, check **Include Type** to include the abbreviation for each window's type in its Automatic Label. For example, 3050DH describes a 3050 double hung window. This also affects the Label column of any schedule the window is listed in.

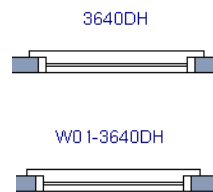

- For a selected door, check **Include Type** to include the hinge side and whether each door is interior or exterior in the Size column of any schedule that the door is listed in. This also affects the Label column of the schedule, but does not affect the door's Automatic Label itself.

 An alternative to displaying Type information in the Label and/or Size columns is to include the Type column in a schedule. See [Columns to Include on page 689](#).

- Select **Specify Label** to replace the selected object's Automatic Label with whatever you type in the text field below. Press the Enter key while the cursor is in the text field to begin a new line. When Specify Label is chosen, the text of the selected object's Automatic Label initially populates the text field.
- Click the **Insert Macro**  button to insert a Global, User Defined or Object Specific Text Macro into the custom label. See [Text Macros on page 540](#).
- Only available for layout boxes, select **Use Callout** to replace the regular text label with a callout shape. Click the **Edit** button to specify the callout's attributes, including macros that report information about the view, in the Callout Specification dialog. See [Callout Specification Dialog on page 526](#).
- Only available for layout boxes, select **Use Marker** to replace the regular text label with a marker. Click the **Edit** button to specify the marker's attributes, including macros that report information about the view, in the Marker Specification dialog. See [Marker Specification Dialog on page 531](#).
- Specify whether to **Use Default Formatting** for any inserted macros that report size information. See [Default Label Formatting on page 700](#).
- Check **Display Border** to turn on the display of a border polyline around the selected object's label.
- Select an **Alignment** option from the drop-down list to apply to the selected object's label text.

- When **Auto Adjust Text Direction** is checked, label text is oriented relative to the bottom or the right side of the view window, depending on the object's angle. When unchecked, label text is oriented relative to the object's front edge or interior side, regardless of the object's angle.

### 3 Position and Orientation

In plan files, these settings affect a selected object's label in either all plan views or the currently active cross section/elevation view. The defaults for these settings only affect plan views - in other types of views, labels are always initially placed at 0, 0, 0°. See *Default Settings on page 77*.

Note: The type of view that is currently active is noted at the beginning of this heading label: Plan View, Camera View, Wall Detail, or CAD Detail. If an architectural object's specification dialog is accessed using the Open Row Object(s) edit tool in a CAD Detail, the Plan View settings will be available. See *Open Row Object(s) on page 686*.

- Specify the **X Offset** value, moves the label side to side relative to the midpoint of the object's front face.
- Specify the **Y Offset** value, which moves the label forward or backward relative to the object's front face.
- Specify the **Angle**, which rotates the label either relative to the angle of its object's front face or to an absolute angle.
- Select **Relative Angle** to measure the label's Angle relative to its object's front face.
- Select **Absolute Angle** to measure the label's Angle relative to an imaginary horizontal line drawn in the positive X direction from the origin. See *3D Drafting on page 13*.
- Regardless of which way the selected object is facing, in plan view the **X Offset** will move the label parallel with the object's front face. The **Y Offset** value will move the label perpendicular to the object's front.
- In cross section/elevation views, the **Offset X** will move the label side to side and the **Offset Y** will move it up or down.
- Specify the **Reference**, which is the point on the selected object from which the X and Y Offset are measured from. Only available for layout boxes and, in plan view only, for cabinets, symbol objects, and architectural blocks.

### 4 Camera View Display

These settings are only active if you open an object's specification dialog in a cross section/elevation view, and only affect the display of the selected object's label in the current view. Not available for cameras or layout boxes.

- Select **Automatic** to display the object's label when the surface at its center point is visible in the view.
- Select **Show in this View** to display the object's label regardless of whether its center point is visible.
- Select **Hide in this View** to suppress the object's label regardless of whether its center point is visible.

### 5 Label Layer

Specify which layer the object's label is placed on. See *Layers on page 176*.

- Select **Use System Layer** to place the object's label on the system default layer for the selected object type's labels. The name of this layer is reported here in parentheses for reference.
- Select **Use Object Layer** to place the object's label on the same layer as the object itself. The name of this layer is reported here in parentheses for reference.

- Select **Use Custom Layer** to select any layer saved in the current file from the drop-down list.
- When Use Custom Layer is selected, you can click the **Define** button to open the Layer Display Options dialog and select, modify, or add a new layer. See *Layer Display Options Dialog on page 179*.

## 6 Preview

In most specification dialogs, a preview of the selected object displays here. In the preview pane, labels can be seen in Plan View only. Only the regular object label is shown: even when the object has a schedule callout label. See *Dialog Preview Panes on page 22*.

---

## Schedule Panel

 The SCHEDULE panel is found in the specification and defaults dialogs for a variety of different objects. The settings on this panel let you assign the selected object to one or more schedule categories. See *Schedule Categories on page 684*.

The settings on this panel are not active in for architectural blocks unless **Treat as One Object** is checked in the Architectural Block Specification dialog. See *General Panel on page 1011*.

- Check **Include in Schedule** to list the selected object in any schedule that includes its Schedule Category.
- Select **Auto Schedule Category** to assign the selected object to a schedule category based on its type.
- Select **Include in Schedule As** to enable the settings that follow and assign the selected object to one or more categories in the list.

In the list of schedule categories:

- Click the arrow to the left of a heading to expand it and see the categories listed under it, or to collapse it again.
- Check the box beside a category to list the selected object in any schedule set to include that category.
- Heading level items often have a check box with a solid fill, indicating that some items listed under it are checked while others are not. If you click to check the box, all items under the heading will become selected; if you click again to clear the box, no items under it will be selected.
- The “Custom” heading will not be available to select if no Custom Schedule Categories have been created.
- Click the **New Custom Category** button to open the New Custom Category dialog. Type a short, descriptive name and click OK to have the new category display in the list under the “Custom” heading. See *Custom Schedule Categories on page 684*.



# Foundations

## Chapter 20

There are three foundation types in Chief Architect Premier: stem walls with footings, grade beams on piers, and monolithic slab. All three can be generated automatically or manually. The foundation type can be specified in the Foundation Defaults dialog when the foundation is built on Floor 0.

There can be only one foundation level in a plan, Floor 0; however, foundation structures can be drawn on any floor using the Foundation and Slab Tools.



Always consult registered geotechnical and civil engineers for information regarding the proper foundation for your site.

### TOPICS

<b>Foundation Defaults</b> .....	<b>706</b>
<b>Foundation Defaults Dialog</b> .....	<b>706</b>
<b>Building a Foundation</b> .....	<b>710</b>
<b>Displaying Foundations</b> .....	<b>711</b>
<b>Editing Foundations</b> .....	<b>713</b>
<b>Deleting Foundations</b> .....	<b>716</b>
<b>Foundations and Rooms</b> .....	<b>716</b>
<b>Foundations and the Terrain</b> .....	<b>717</b>
<b>The Slab Tools</b> .....	<b>719</b>
<b>Editing Slabs</b> .....	<b>720</b>
<b>Slab Specification Dialog</b> .....	<b>720</b>
<b>Editing Piers and Pads</b> .....	<b>722</b>
<b>Pier/Pad Specification Dialog</b> .....	<b>723</b>
<b>Fireplaces</b> .....	<b>724</b>
<b>Fireplace Specification Dialog</b> .....	<b>726</b>
<b>Library Fireplaces</b> .....	<b>728</b>
<b>Chimneys</b> .....	<b>728</b>

---

## Foundation Defaults



There are several defaults dialogs that affect the foundation. They can be accessed by selecting **Edit> Default Settings**.

In the Default Settings dialog, select “Foundation” and click the **Edit** button to open the Foundation Defaults dialog.

If a foundation has been built, it will have a Floor 0 Defaults dialog. The structural settings in this dialog are initially drawn from those in the Foundation Defaults dialog. See *Floor Defaults Dialog on page 731*.

The Foundation Wall Defaults and Slab Footing Defaults dialogs control the default setup of Foundation Walls and Slab Footings. See *Wall, Railing, and Fencing Defaults on page 343*.

The default attributes for Slabs and Slabs with Footings can be set in the Slab Defaults dialogs. See *The Slab Tools on page 719*.

The default attributes for Post footings can be set in the Framing Defaults/Build Framing dialog. See *Build Framing Dialog on page 860*.

---

## Foundation Defaults Dialog



The Foundation Defaults dialog allows you to specify stem wall height, slab thickness, sill plates, and other characteristics of an automatically-generated foundation. These values determine how a new foundation is generated as well as the sizes for manually drawn foundation walls added to an existing foundation. Select **Edit> Default Settings**, and in the Default Settings dialog, select "Foundation" and click the **Edit** button.

The settings in the Foundation Defaults dialog are similar to those in the Build Foundation dialog, which opens when **Build> Floor> Build Foundation**  is selected. The primary difference is that when you click **OK** in the Foundation Defaults dialog, no changes are made to the model. See *Building a Foundation on page 710*.

## FOUNDATION PANEL

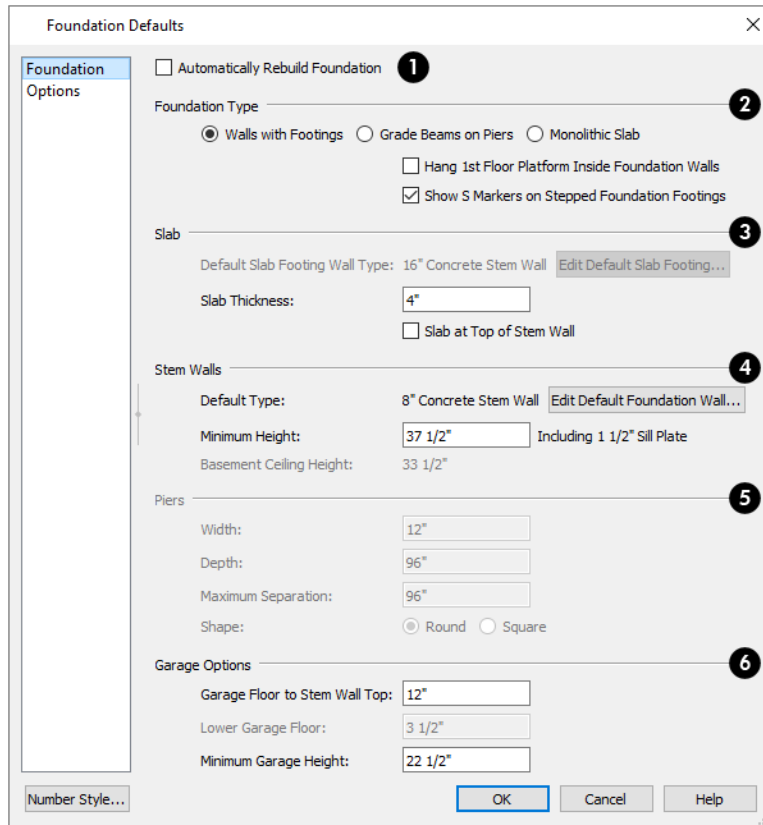

### 1 Automatically Rebuild Foundation

Check **Auto Rebuild Foundation** to automatically rebuild the foundation whenever changes are made to Floor 1 that affect the structure of the foundation. See [Rebuilding Foundations on page 713](#).

### 2 Foundation Type

Three different **Foundation Types** can be created in Chief Architect. Each type of foundation has different default settings, options, and behaviors. Select the radio button next to the desired type.

- Select **Walls with Footings** to produce a foundation composed of stem walls with footings that run continuously under the base of the walls.
- Select **Grade Beams on Piers** to generate a pier and grade beam foundation. The floor framing rests directly on top of the grade beams.
- Select **Monolithic Slab** to build a slab foundation defined by Slab Footings. The foundation forms the floor platform for Floor 1. It is visible on Floor 0 and can be selected and edited. See [Foundation Walls on page 352](#).
- Check **Hang 1st Floor Platform Inside Foundation Walls** to produce stem walls that build up to the top of the floor platform of Floor 1. When unchecked, the stem walls build to the bottom of the floor platform, which bears on top of them. Only available when Walls with Footings is selected, above.

- Check **Show “S” Markers on Step Foundation** to include an “S” symbol in plan view anywhere there is a step in foundation wall height. Not available when Grade Beams on Piers is selected, above. See *Displaying Foundations on page 711*.

### 3 Slab

- The name of the **Default Slab Footing Wall Type** displays here for reference. Click the **Edit Default Slab Footing** button to open the Wall Type Definitions dialog and change the definition of the default wall type. Only available when Monolithic Slab is the selected Foundation Type.
- Specify the **Slab Thickness**, which is the thickness of the slab produced above the footing or at the top of the stem wall.
- Check **Slab at top of Stem Wall** to raise the slab so its top is flush with the top of the stem walls. Only available when Walls with Footings is the selected Foundation Type.  
If **Slab at top of Stem Wall** is selected, all rooms on the first floor are automatically set to **Floor Supplied by the Foundation Room Below** in the Room Specification dialog. See *Structure Panel on page 439*.

### 4 Stem Walls

- The name of the **Default Foundation Wall Type** displays here for reference.
- Click the **Edit Default Foundation Wall** button to open the Foundation Wall Defaults dialog and change the default settings for foundation walls. See *Foundation Walls on page 352*.
- If Monolithic Slab is the selected Foundation Type, the **Edit Garage Curb** button will be available. Click it to open the Foundation Wall Defaults dialog and define the walls that form curbs around Garage and Slab rooms.
- Specify the **Minimum Height**, which is the minimum height for foundation stem walls and grade beams and includes the sill plates.
- The **Basement Ceiling Height** displays here as a reference. This is the distance from the top of the slab floor to the basement ceiling and is equal to the Minimum Wall Height minus the Slab Thickness.

If the Minimum Wall Height is at least 76” (1900 mm), a Ceiling Finish is added to the foundation room automatically. A slab floor is also generated above the footing. The ceiling height and finish can be changed later. To remove this slab, specify the room areas in the basement as “Open Below”. See *Room Specification Dialog on page 437*.

### 5 Piers

These settings are only available when Grade Beams on Piers is the selected Foundation Type.

- Specify the **Width, Depth, and Maximum Separation** of the piers.
- Choose either **Round or Square** piers.

### 6 Garage Options

These settings only apply to rooms defined as Garages. See *Garages on page 716*.

- Specify the **Garage Floor to Stem Wall Top**, which is the distance between the slab and the tops of the stem walls in both Garage and Slab rooms. Available for Walls with Footings and Grade Beams on Piers foundation types. See *Foundation Defaults on page 706*.

Note: The Garage Floor to Stem Wall Top setting only affects Garage rooms that have a Floor Height of 0. See [Structure Panel on page 439](#).

- Specify the **Lower Garage Floor** height, which is the distance that Garage and Slab room floors are lowered when a Monolithic Slab foundation is built. This value is also the height of the curbs around these rooms.
- Specify the **Minimum Garage Height**, which is the minimum height that stem walls defining a Garage foundation will be, regardless of the Minimum Stem Wall Height for the rest of the foundation.

## OPTIONS PANEL

The OPTIONS panel allows you to include rebar and other materials related to the foundation in the Materials List. See [Materials Lists on page 1303](#).

Some options on this panel may be unavailable depending on the foundation type selected on the FOUNDATION panel.

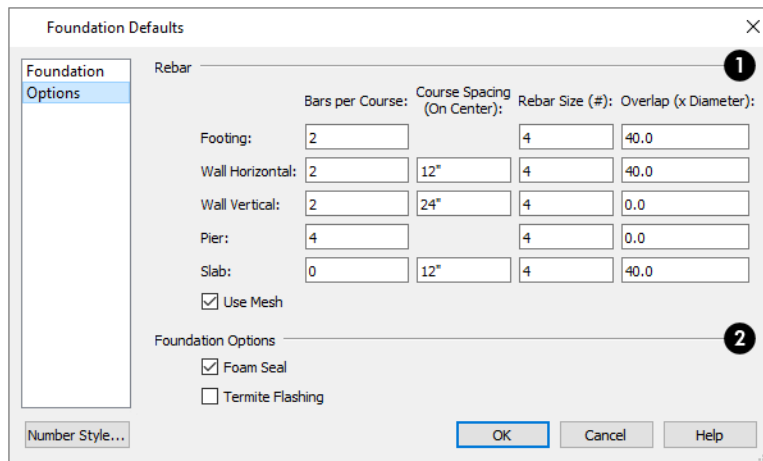

### 1 Rebar

Specify the **Rebar** used in the major foundation components: **Footing**, **Wall Horizontal** courses, **Wall Vertical** courses, **Pier**, and **Slab**. Rebar and mesh are calculated in the Materials List provided that the wall or footing they are associated with is the “Concrete” Structure Type; but, they do not display in any 2D or 3D views of the model. See [The Materials List Tools on page 1304](#).

- **Bars per Course** - Specify the number of bars of rebar to be used per course for each foundation component.
- **Course Spacing** - Define the spacing for Vertical and Horizontal Wall courses, and for Slabs. If slabs are to have rebar instead of mesh, this spacing value applies to both directions.
- **Rebar size** - Define the rebar size in 1/8th inches. 4 represents 4/8, or 1/2 inch.
- Specify the **Overlap** where sticks of rebar meet, in terms of the rebar’s **Diameter**. A value of 40.0, for example, equals 40 times the Rebar Size.
- Check **Use Mesh** to reinforce the slab floor with mesh instead of rebar, or uncheck it to use rebar.

### 2 Foundation Options

Select either **Foam Seal**, **Termite Flashing**, or both. These options are added to the Materials List, but do not display in the model.

---

## Building a Foundation

 Foundations can be generated automatically or drawn manually. A combination of the two methods can also be used.

Three foundation types are available: stem walls with footings, grade beams on piers, and monolithic slabs. The first two options are created using walls; the last creates concrete slabs with footings.

Automatically built foundations are placed on Floor 0 and are based on wall positions and floor heights on Floor 1. Foundation walls or slab footings are generated under:

- All exterior walls on Floor 1 that define a room that has **Build Foundation Below** specified. In order to automatically receive a foundation wall below, Exterior walls cannot be Railings or Invisible. See [Room Definition on page 413](#).
- Any Railings, Invisible Walls, and interior walls on Floor 1 that have **Create Wall/Footing Below** checked in the Wall Specification dialog. See [Foundation Panel on page 400](#).
- Any interior walls on Floor 1 defining rooms with different floor heights. See [Floor and Ceiling Heights on page 426](#).

At least one room that has **Build Foundation Below** specified must be defined by visible, non-railing walls on Floor 1 for a foundation to be automatically generated. If no rooms are defined on Floor 1, a blank Floor 0 is created.

There can be only one Floor 0 per plan. If your plan requires a foundation on more than one floor, you will need to draw the required foundation walls or slabs yourself.

### *To build an automatic foundation*

1. Specify the desired floor heights for the rooms on Floor 1: particularly Porch and Garage rooms.
2. Select **Build> Floor> Build Foundation** .
3. Specify the desired foundation type and other information in the Build Foundation dialog. The settings in this dialog are similar to those in the Foundation Defaults dialog. See [Foundation Defaults Dialog on page 706](#).
4. In the New Floor dialog, select **Derive new Foundation plan from the 1st floor plan** and click **OK** to build a foundation based on Floor 1.

If you prefer, you can instead select **Make new (blank) plan for the Foundation** to create an empty foundation level where you can manually draw foundation walls or slabs.

In most cases, it is preferable to base Floor 0 off the first floor plan and then manually edit the foundation as needed. See [Editing Foundations on page 713](#).





## FOUNDATION WALL ALIGNMENT

By default, foundation walls and slab footings will align with walls on the floor above along the outside surface of the Main Layer of both wall types. If you prefer, you can specify that foundation walls align to a different part of the walls above. See [Aligning Walls on page 375](#).

## MIXING FOUNDATION TYPES

You can also create a foundation that combines stem walls, grade beams and piers, and/or monolithic slabs.

### ***To create a foundation of multiple types***

1. Begin by specifying any rooms on Floor 1 that require a slab floor as either a Garage or Slab **Room Type**. See *Foundations and Rooms on page 716*.
2. Alternatively, or in addition, you can specify any rooms on Floor 1 as having a **Monolithic Slab Foundation**. See *Structure Panel on page 439*.
3. **Build Foundation** , as described above.
  - If the foundation will include any grade beams and piers, specify **Grade Beams on Piers** as the **Foundation Type** and build the foundation.
  - If the foundation will include a combination of stem walls and slabs, specify **Walls with Footings** as the **Foundation Type**.
4. Once the foundation walls have been generated, they can be moved or deleted, and new **Foundation Walls** , **Slab Footings** , and/or **Slabs**  can be drawn. See *Foundation Walls on page 352* and *The Slab Tools on page 719*.

### **OPENINGS IN FOUNDATION WALLS**

Any doors placed in walls around a Garage will receive cutouts in the garage stem wall or curb. The width of that cutout can be specified in the Door Specification dialog. See *General Panel on page 559*.

---

## **Displaying Foundations**

The objects associated with foundations can be displayed in a variety of ways in Chief Architect.

### **FOUNDATION LAYERS**



The display of foundation walls, slabs, curbs, piers and footings is controlled in the **Layer Display Options** dialog. See *Layer Display Options Dialog on page 179*.

- Foundation Walls, including grade beams, Slab Footings and Garage curbs, are placed on the “Walls, Foundation” layer by default.
- Footings under Slab Footings and Foundation Walls are placed on the “Footings” layer by default, as are foundation piers.
- Post footings and deck post footings are placed on the “Footings, Post” and “Footings, Deck Post” layers by default.
- Slabs created using the **Slab Tools**  are placed on the “Slabs, Custom” layer by default.
- Wall labels and slab labels are placed on the “Walls, Labels” and “Polylines 3D, Labels” layers, respectively.
- In stem wall and grade beam foundations, brick ledge lines in plan view are on the “Slabs” layer; in monolithic slab foundations, they are on the “Walls, Foundation” layer. See *Brick Ledges on page 353*.
- The “Foundations” layer controls the display of all objects on Floor 0 in 3D views but does not affect plan view.

### **IN PLAN VIEW**

The appearance of foundation wall types, including line weights, colors and fill styles, is specified in the Wall Type Definitions dialog. See *Wall Type Definitions Dialog on page 387*.

The fill style for wall footings can be set in the Wall Specification dialog, while footing line style is controlled by the "Footings" layer. You can place footings on a custom layer if you wish. See [Foundation Panel on page 400](#).

Changes in stem wall and monolithic slab foundation heights are represented in plan view with S markers. These markers are located on the "Footings, Step Markers" layer and use the Text Style assigned to that layer. See [Stepped Foundations on page 718](#).

If a door on Floor 1 extends into a stem wall or curb defining a Garage room, its location will be indicated on Floor 0. See [Displaying Doors on page 548](#).

## WALL AND SLAB LABELS



Foundation walls and Slabs can both display labels when the "Walls, Labels" and "Polylines 3D, Labels" layers are on. Unlike some objects, walls and slabs have blank Automatic Labels; however, you can specify a custom label in their specification dialogs. See [Wall Specification Dialog on page 392](#) and [Slab Specification Dialog on page 720](#).

Wall and Slab labels display in floor plan and cross section/elevation views when their respective layer is turned on and use the Text Style assigned to that layer. See [Label Panel on page 700](#).

## IN 3D VIEWS

In 3D views, all objects on Floor 0 will only display when the "Foundation" layer is turned on.

While the display of foundation walls and their footings can be controlled independent of one another in plan view, in 3D views this is not the case. If a foundation wall is set to display, its footing will as well - even if the "Footings" layer is turned off. The reverse is also true - if a foundation wall's display is turned off, so will its footing's.

The display of monolithic slab foundations in 3D views is controlled by the "Foundation" layer. **Slab Footings**  are located on the "Walls, Foundation" layer; but if this layer is turned off, any **Slab Footings**  that define a foundation room will continue to display as long as the "Foundation" layer is on.

## IN CROSS SECTIONS

When the **Auto Detail**  tool is used in a cross section view, the fill style of each wall layer as set in its Wall Type Definition is used. See [Detailing Cross Section/Elevation Views on page 1094](#).

Foundation wall footings and **Slabs**  use a concrete fill that cannot be specified beforehand but can be edited once **Auto Detail** has been generated.

Monolithic slabs and their footings use the fill style specified for the slab room's Floor Structure definition. See [Floor and Ceiling Platform Definitions on page 429](#).

You can choose to override the default line color, style, and weight of objects below grade in the Cross Section/Elevation Specification dialog. These settings do not affect any CAD objects created in the view: including those generated by Auto Detail. See [Below Grade Panel on page 1127](#).

## IN THE MATERIALS LIST



The materials that make up foundation walls, footings, and slab floors are listed under the Foundation category in the Materials List, including:

- Concrete for walls, slabs, and footings
- Rebar for walls and footings
- Rebar or mesh for slabs



Slab Footings and the room areas that they define can be assigned **Pour Numbers** in their specification dialogs. Typically, a Slab Footing will have the same Pour Number as the room it defines, although it is possible for it to define multiple rooms with differing Pour Numbers. Pour Numbers are listed separately under the Foundation category of the Materials List. See [Foundation Panel on page 400](#) and [Structure Panel on page 439](#).

Other objects relevant to foundations can be found in these categories:

- **Exterior Trim** - Lists slabs drawn with the **Slab**  tools that are located outside a structure.
- **Interior Trim** - Lists slabs drawn with the **Slab**  tools that are located inside a structure.

See [Materials Lists on page 1303](#).

## IN SCHEDULES

Foundation walls, Round Piers/Square Pads, Slabs, as well as holes in Slabs, can be included in schedules. See [The Schedule Tools on page 682](#).

Foundation walls are listed in the "Walls" category by default; Piers and Pads are listed in the "Piers/Pads" category; and Slabs and Slab Holes are listed in the "Slabs" category. You can, however, assign a selected object to the category of your choice in its specification dialog. See [Schedule Panel on page 704](#).

---

# Editing Foundations

Stem wall with footings, wall with piers and monolithic slab foundations are all created using walls which enclose room areas.

- Foundation walls can be selected and edited much like other walls. See [Editing Walls on page 368](#).
- Footing size can be changed on a wall by wall basis. See [Footing Width and Height on page 714](#).
- Foundation rooms can also be selected and edited like other rooms. See [Foundations and Rooms on page 716](#).

## REBUILDING FOUNDATIONS

By default, foundations do not update automatically when changes are made to the structure on Floor 1. For example, if exterior walls are moved or floor platforms are raised or lowered, the foundation must be rebuilt.

You can direct the program to rebuild an automatically generated foundation whenever changes are made on Floor 1 that affect the foundation by checking **Auto Rebuild Foundation** in the Foundation Defaults dialog. See [Foundation Defaults on page 706](#).

You can also rebuild an automatically generated foundation by selecting **Build> Floor> Build Foundation**  from the menu.

When **Auto Rebuild Foundation** is enabled, walls cannot be edited, manually drawn or deleted on Floor 0. When the foundation is rebuilt, any manually drawn or edited walls are deleted. Similarly, rooms on Floor 0 cannot be edited while this option is enabled. If you try to draw a wall or edit a room or a wall while **Auto Rebuild Foundation** is turned on, a warning message will display.

## CHANGING FOUNDATION TYPES

When a foundation is generated, the program creates Floor Defaults settings for Floor 0 based on the information in the Build Foundation dialog. If you specify a Monolithic Slab foundation, the default Floor Structure on Floor 1 will also be changed to a slab rather than a framed platform. See [Floor Defaults Dialog on page 731](#).

 To avoid unexpected results, it is recommended that you not change the Foundation Type once the foundation is built.

## STEM WALL HEIGHT

When a foundation is created, all of Floor 0 uses the stem wall height specified in the Foundation Defaults dialog,

This height is measured from the bottom of floor platform of Floor 1 to top of the stem walls' footings. If Floor 1 has multiple floor platform heights, the foundation stem walls will be stepped.

Once a foundation is created, stem wall heights can be adjusted either on a room-by-room basis or for individual walls.

### *To change a room's stem wall height*

1. Select a room on Floor 0 and click the **Open Object**  edit button.
2. Specify the desired **Stem Wall Height** in the Room Specification dialog. See [General Panel on page 438](#).
3. If you wish to reduce the **Stem Wall Height**, you will first need to reduce the **Ceiling Height** value by the same amount.

If adjacent rooms have stem wall heights that differ by at least 1/16 of an inch, the stem wall separating them uses the larger of these two values.

In 3D views, individual stem walls can be selected and edited. In most cases, this method should only be used for stepping the bottom of the foundation wall. See [Stepped Walls and Footings on page 381](#).

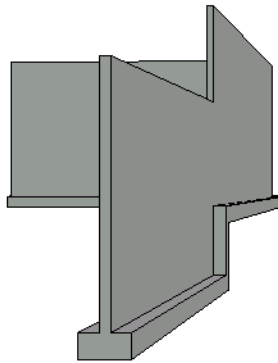

## FOOTING WIDTH AND HEIGHT

Foundation Wall footings derive their Width, Height, and Offset from in the Foundation Wall Defaults dialog, Similarly, Slab Footings use the width and height specified in the Slab Footing Defaults dialog. Once a Foundation Wall or Slab Footing is created, its footing can be adjusted in its specification dialog. See [Foundation Panel on page 400](#).

Footing Width can be adjusted using the edit handles in both floor plan and 3D views. Each side of the footing can be edited independently, which means that the Offset can also be modified using the footing resize edit handles.



If the selected wall is a Slab Footing, the footing width can also be resized using dimensions and will resize the Wall Thickness, creating a new wall type if necessary. See [Editing Walls on page 368](#).

Stem wall footing heights can also be edited in 3D views just as the rest of the stem wall can. Slab Footing heights, on the other hand, cannot be adjusted in 3D. See *Stepped and Raked Walls on page 381*.

You can specify whether stepped stem walls have vertical footings on the FOUNDATION panel of the Foundation Wall Defaults and Specification dialogs. You can also specify the chamfer width and height of monolithic slab foundation footings.

## INTERIOR FOOTINGS

Slab foundations often have interior footings: to support posts, for example. You can specify that an interior footing be created under an interior wall on Floor 1 when the foundation is built by checking **Create Wall/Footing Below**. See *Foundation Panel on page 400*.

You can also draw interior footings using the **Slab Footing**  tool. See *Foundation Walls on page 352*.

If an interior footing is inside a room with a slab foundation and a curb, as in a garage, specify the **Slab Footing**  as **Invisible** to prevent a curb from generating inside the room. See *Room Dividers and Invisible Walls on page 355*.

## THICKENED SLABS

A thickened slab can be created by selecting a **Slab Footing**  and specifying its **Chamfer Height** to equal the **Footing Height**. The **Chamfer Width** can be increased, as well.

- When the Slab Footing is drawn on the interior of a slab room, a thickened slab is created.

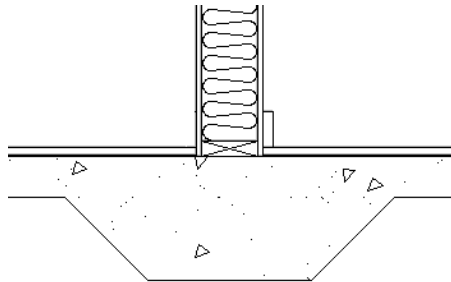

- When the Slab Footing defines the edge of a slab, a thickened slab edge results.

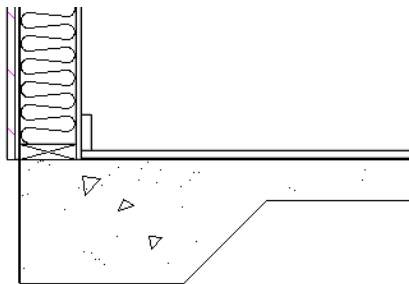

You can also specify the **Chamfer Height** and **Width** before the Slab Footings are created in the Slab Footing Defaults dialog. See *Foundation Panel on page 400*.

---

## Deleting Foundations



Select **Build> Floor> Delete Foundation** to delete the entire foundation floor.

You can also select and delete individual foundation walls and slabs by clicking the **Delete**  edit button or pressing the Delete key. See [Deleting Objects on page 284](#).

Deleting and rebuilding the foundation is often the quickest way to update the model when substantial changes are made to Floor 1 after the foundation is built.

---

## Foundations and Rooms

When a foundation plan is created, rooms included in the Living Area calculation generate a stem wall, grade beam, or slab foundation below them. Garage rooms generate slab foundations, but exterior rooms such as Decks, Courts and Balconies do not generate any foundation. See [Room Types and Functions on page 415](#).

Interior foundation walls are not generated unless:

- They separate the area under a Slab or Garage room from the rest of the plan;
- They separate the area under a room specified as having a slab foundation from the rest of the plan;
- They define areas under rooms with different floor heights.
- A wall on Floor 1 is specified as a **Bearing Wall** in the Wall Specification dialog. See [Foundation Panel on page 400](#).

Note: To remove all or part of the concrete slab in the basement area, select a basement room and define it as Open Below in the Room Specification dialog.

### GARAGES

When a foundation is generated based on the floor plan of Floor 1, a room on the first floor specified as either a Garage or Slab type will receive a stem wall or pier foundation with a slab floor and stem walls. If a monolithic slab foundation is generated, the room will receive a slab floor with curbs.

An opening placed in a wall defining a Garage will receive a cutout in the stem wall or curb that displays in plan view on the floor below provided that the stem wall or curb's Main Layer has a Concrete or Brick material type.

The width of the concrete cutout can be defined and you can specify whether the cutout displays in the Door or Window Specification dialog. See [Framing Panel on page 573](#).

By default, a room on Floor 1 specified as a Garage or a Slab will be assigned a lower floor height when the foundation is built. The amount that it is lowered depends on the foundation type:

- The floor height will drop the default thickness of the floor platform for Floor 1 plus 12" (300 mm) in a Walls with Footings or Grade Beams on Piers foundation.
- The floor height will drop 3 1/2" (88 mm) in a Monolithic Slab foundation.

These values are set in the Foundation Defaults dialog. See [Foundation Defaults on page 706](#).

### ***To build a Garage slab with stem walls***

1. Before the foundation is generated, specify the room as a Garage or Slab.
2. Build an automatic Wall with Footings or Grade Beam on Piers foundation.

In the Floor 1 Garage's Room Specification dialog, **Floor Supplied by the Foundation Room Below** will now be checked. See [Structure Panel on page 439](#).

By default, the program produces a 4" (100 mm) slab and 24" (600 mm) high stem walls around the garage. These stem walls are drawn on Floor 0 and will indicate the locations of any doors that extend into them.

### ***To build a Garage slab with curbs***

1. Before the foundation is generated, specify the room as a Garage or Slab.
2. Build an automatic Monolithic Slab foundation, specifying the required Lower Garage Floor value.

By default, the program produces a 4" (100 mm) slab and 3 1/2" (88 mm) high curb around the garage. The curbs are drawn using Slab Footings on Floor 0, use the Default Foundation Wall type, and will indicate the locations of any doors that extend into them.



The floor height of the garage and the stem wall or curb height can then be adjusted, if necessary, in the Garage room's Room Specification dialog. See [Structure Panel on page 439](#).

## **BASEMENT ROOMS**

When a foundation's type is Walls with Footings or Grade Beams on Piers, and it is assigned a Basement Ceiling Height of 48" (1200 mm) or greater, the resulting basement is automatically included in the Living Area calculation. It does not, however, have a floor or ceiling finish.

When a foundation is assigned a Basement Ceiling Height of 72" (1800 mm) or greater, the resulting basement is automatically created with a 4" (100 mm) concrete slab floor and a default Floor Finish like that on Floor 1. Similarly, it is automatically given a painted drywall Ceiling Finish. See [Foundation Defaults on page 706](#).

Regardless of its ceiling height, however, you can specify a floor or ceiling finish for any room in the Room Specification dialog. See [Structure Panel on page 439](#).

The resulting basement can be divided into separate rooms using **Interior Walls**  or any wall type you wish. If the rooms in a basement have different floor heights, it is best to separate them using walls specified as **Foundation Walls** .

---

## **Foundations and the Terrain**

Chief Architect automatically raises the structure in a plan a set distance above the terrain. See [Terrain Height vs Floor Height on page 1245](#).

In a plan with a foundation present, the terrain will be:

- 6" (187 mm) below the top of the stem walls or grade beams in a Walls with Footings or Grade Beams on Piers foundation.
- 8" (200 mm) below the top of the slab in a Monolithic Slab foundation.

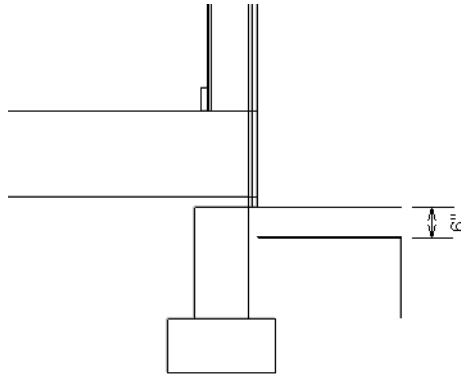

By default, the program will also create a flattened pad under the building footprint.

Not all foundations have these requirements, of course, so you can customize your foundation and terrain to suit your needs.

### DAYLIGHT BASEMENTS

Daylight basements, also referred to as look-out basements, have walls that are tall enough for basement windows to be positioned above the terrain. They are often found in split level or split entry structures.

To create a daylight basement condition, build a stem wall foundation and modify these settings in the Terrain Specification dialog:

- Uncheck **Auto Calculate Elevation**.
- Increase the **Building Pad Elevation**, which is the distance between the default floor height of Floor 1 and the terrain.

### WALKOUT BASEMENTS

Walkout basements are a type of daylight basement typically located on sloped terrain. They feature walls that are above ground at the lower end of the slope so that a door can be positioned above the terrain at that end.

To create a walkout basement, build a stem wall foundation and modify these settings in the Terrain Specification dialog:

- Uncheck **Flatten Pad**.
- Uncheck **Auto Calculate Elevation**.

You will also need to create sloped terrain and adjust the **Building Pad Elevation** and/or terrain data so that the terrain is at the appropriate height relative to the structure at both the high and low ends of the slope.

### STEPPED FOUNDATIONS

Stepped foundations are usually built on sloping terrain. A stepped foundation will be produced automatically if more than one floor height is present on Floor 1 when the foundation is built.

In plan view, steps in stem wall and monolithic slab foundations are represented using S markers. See [Displaying Foundations on page 711](#).

As with a walkout basement, you will need to build a stem wall foundation and modify these settings in the Terrain Specification dialog:

- Uncheck **Flatten Pad**.
- Uncheck **Auto Calculate Elevation**.

You will also need to create sloped terrain and adjust the **Building Pad Elevation** and/or terrain data so that the terrain is at the appropriate height relative to the structure at both the high and low ends of the slope.



You can also create a stepped foundation by editing foundation rooms and walls. See *Stem Wall Height on page 714*.

---

## The Slab Tools

 Select **Build> Slab** to access the Slab Tools.



### SLABS

  Select **Build> Slab> Slab** or **Slab With Footing**, then either click or click and drag a rectangle to draw a slab. The Slab Tools are intended for generic purposes than foundations and should not be substituted for a foundation plan. See *Rectangular Polyline on page 319*.

A newly drawn **Slab** or **Slab With Footing** inherits the settings in the Slab Defaults or Slab with Footing Defaults dialog. Once created, slabs can be edited like other closed polylines. See *Editing Slabs on page 720*.



A slab is also created when the **Post with Footing**  tool is used. See *Post with Footing on page 857*.

### SLAB HOLES

  A hole can be placed in a slab or in the floor of a foundation slab with footings. Select **Build> Slab> Slab Hole** or **Build> Slab> Slab Hole With Footing**, then either click or click and drag within an existing slab to create a hole.

You can also create a Slab Hole in a Slab, or a Slab Hole with Footing in a Slab with Footing, using the **Create Hole**  edit tool. See *Polyline Holes on page 232*.

### PIERS AND PADS

  Piers and pads can be manually placed under walls, railings, or beams on any floor. Select **Build> Slab> Round Pier** or **Build> Slab> Square Pad** and click in plan view to place a pier or pad.

For information about editing Round Piers and Square Pads, see *Editing Piers and Pads on page 722*.

### EDITING SLABS AND PIERS/PADS

Once created, slabs and Slab Holes can be selected in 2D and 3D views both individually and as a group and can be edited using the edit handles, the Edit Toolbar, and the Slab Specification dialog. See *Slab Specification Dialog on page 720*.

Slabs and Slab Holes can be edited like other closed-polyline base objects in both 2D and 3D views. See *Editing Closed Polyline-Based Objects on page 228*.

### USING THE EDIT TOOLS

One or more selected Slabs or Slab Holes can be edited in a variety of ways using the buttons on the Edit Toolbar. As with most objects, Slabs can be copied, replicated, moved, deleted, etc. See *The Edit Toolbar on page 130*.

You can set the attributes of a selected Slab or Slab with Footing as the defaults for that slab type by clicking the **Set as Default**  edit button. This tool is not available for Post Footings. See *Set as Default on page 79*.

## SLABS AND THE MATERIALS LIST

If a slab's material type is specified as Concrete or Volume, the materials list calculates the total volume of the slab and all footings. See *Define Material Dialog on page 1066*.

## Editing Slabs

Slabs and Slab Holes can be selected in 2D and 3D views both individually and as a group and can be edited using the edit handles, the Edit Toolbar, and the Slab Specification dialog. See *Slab Specification Dialog on page 720*.

### USING THE EDIT HANDLES

Slabs and Slab Holes can be edited like other closed-polyline base objects in both 2D and 3D views. See *Editing Closed Polyline-Based Objects on page 228*.

### USING THE EDIT TOOLS

One or more selected Slabs or Slab Holes can be edited in a variety of ways using the buttons on the Edit Toolbar. As with most objects, Slabs can be copied, replicated, moved, deleted, etc. See *The Edit Toolbar on page 130*.

You can set the attributes of a selected Slab or Slab with Footing as the defaults for that slab type by clicking the **Set as Default**  edit button. This tool is not available for Post Footings. See *Set as Default on page 79*.

## Slab Specification Dialog

 Select one or more Slabs and click the **Open Object** edit button to open the Slab Specification dialog.

The options in this dialog are similar to those in the Slab Defaults and Slab with Footing Defaults dialogs, but affect the selected slab(s) only.

### GENERAL PANEL

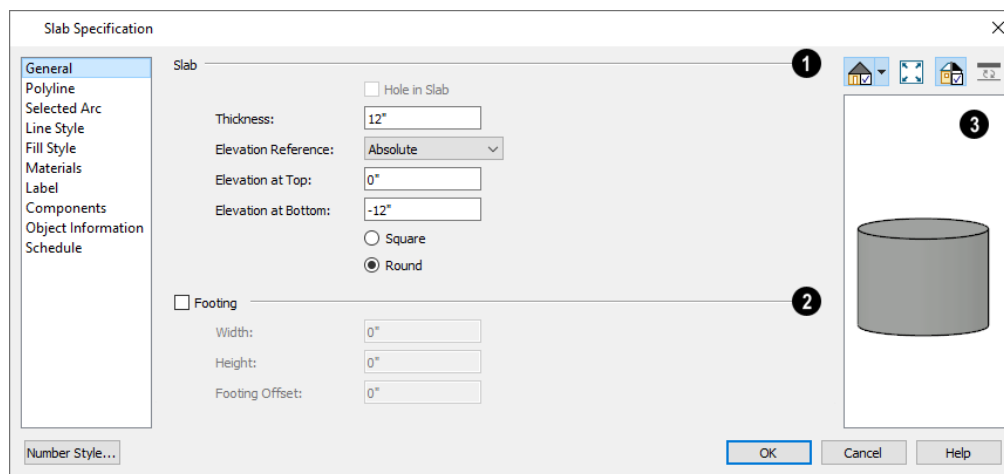



## 1 Slab

Specify the characteristics of the selected **Slab**.

- Check **Hole in Slab** to convert the selected slab into a slab hole. A slab hole must be contained within a larger slab. Not available in either Slab Defaults dialog. See *Slab Holes on page 719*.
- Specify the **Thickness**, which is the measurement from the slab's top to bottom surfaces.
- Select the **Elevation Reference**, from the drop-down list. This determines where the next two settings are measured from and also affects their setting labels.
- Specify the slab's height **to Top**, which is of its top surface measured from the selected Elevation Reference.
- Specify the slab's height **to Bottom**, which is the height of its bottom surface, measured from the Elevation Reference.
- When the selected slab is a Post Footing or Deck Post Footing, specify whether it is **Square** or **Round**. Not available for manually drawn slabs or if the slab's shape has been modified using the **Change Line/Arc**  edit tool. See *Post with Footing on page 857*.

## 2 Footing

Specify the characteristics of the selected slab's **Footing**. Not available in the Slab Defaults dialog.

- Check **Has Footing** if you would like the slab to have a footing around the inside of its perimeter.
- Specify the **Height** and **Width** for the footing.
- Specify the **Footing Offset**, which is the distance that the footing extends out past the edges of the slab. A value of 0 aligns the outside of the footing with the outside of the slab.

## 3 Preview

A preview of the selected slab displays on the right side of the panel. See *Dialog Preview Panes on page 22*.

### POLYLINE PANEL

The POLYLINE panel states the length of the selected slab's **Perimeter**, its enclosed **Area**, and its **Volume**. See *Polyline Panel on page 317*.

If the selected Slab has any Holes in it, they will be subtracted from the **Area** and **Volume** values. See *Slab Holes on page 719*.

### SELECTED LINE PANEL

The SELECTED LINE panel is available when the selected edge is a line as opposed to an arc. For information about the settings on this panel, see *Polyline Specification Dialog on page 317*.

### SELECTED ARC PANEL

The SELECTED ARC panel is available when the selected edge is an arc as opposed to a line. See *Change Line/Arc on page 256*.

### LINE STYLE PANEL

For information about the settings on this panel, see *Line Style Panel on page 305*.

## **FILL STYLE PANEL**

The settings on the FILL STYLE panel affect the selected slab's appearance in plan view. For information about these settings, see *Fill Style Panel and Dialogs on page 193*.

## **MATERIALS PANEL**

For information about the settings on this panel, see *Materials Panel on page 1055*.

## **LABEL PANEL**

Slab labels display in floor plan and cross section/elevation views when the "Polylines 3D, Labels" layer is turned on and use the Text Style assigned to that layer. The Automatic Label for slabs is blank, but you can specify a custom label.

For information about the settings on this panel, see *Label Panel on page 700*.

## **COMPONENTS PANEL**

The information on the COMPONENTS panel can be used in the materials list. For more information, see *Components Panel on page 1330*.

## **OBJECT INFORMATION PANEL**

The information entered on the OBJECT INFORMATION panel can be used in schedules and the materials list. For more information, see *Object Information Panel on page 1331*.

## **SCHEDULE PANEL**

The settings on the SCHEDULE panel determine which schedule categories the selected object is included in. See *Schedule Panel on page 704*.

---

# **Editing Piers and Pads**

Round Piers and Square Pads can be selected individually and in groups in 2D and 3D views and edited using their edit handles and edit toolbars.

There are several ways to move piers and pads; however, they must always be positioned under a wall. A pier or pad can only be moved away from the wall it is placed beneath if it is moved to another wall.

## **USING THE MOUSE**

In plan view, piers and pads can be edited like CAD lines. Three edit handles allow the pier or pad to be resized and moved along the wall it is placed beneath. See *Editing Line-Based Objects on page 216*.

In 3D views, piers and pads can be edited like CAD boxes. See *Editing Box-Based Objects on page 232*.

## **USING DIMENSIONS**

In plan view, piers and pads can also be moved using dimensions. See *Moving Objects Using Dimensions on page 483*.

 If you move a foundation wall or beam, any piers or pads it contains will move with it.

## USING THE EDIT TOOLS

A selected pier or pad can be edited in a variety of ways using the buttons on the Edit Toolbar. As with most objects, piers and pads can be replicated, moved, deleted, etc. See *The Edit Toolbar on page 130*.

---

# Pier/Pad Specification Dialog

 Select a Round Pier or Square Pad and click the **Open Object** edit button to open the Pier/Pad Specification dialog.

## GENERAL PANEL

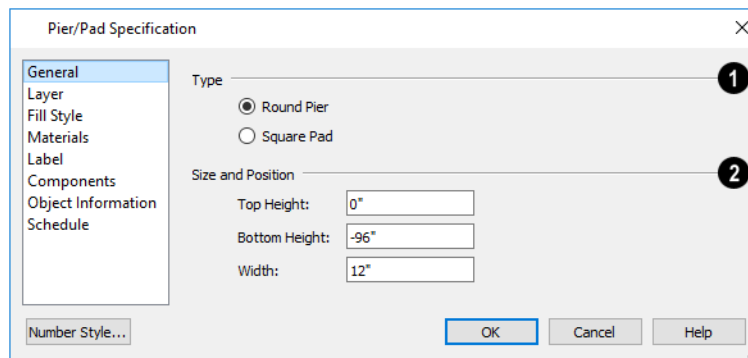

### 1 Type

Specify whether the selected object is a **Round Pier** or **Square Pad**.

### 2 Size and Position

Specify the **Size and Position** of the selected pier or pad.

- Specify the **Top Height** and **Bottom Height**, as measured from zero.
- Specify the selected pier or pad's **Width**.

## LAYER PANEL

For information about the settings on this panel, see *Layer Panel on page 186*.

## FILL STYLE PANEL

The settings on the **FILL STYLE** panel affect the selected pier or pad's appearance in plan view. For information about these settings, see *Fill Style Panel and Dialogs on page 193*.

## MATERIALS PANEL

For information about the settings on this panel, see *Materials Panel on page 1055*.

## LABEL PANEL

Round Pier and Square Pad labels display in floor plan and cross section/elevation views when the “Footings” layer is turned on and use the Text Style assigned to that layer. The Automatic Label for these objects is blank, but you can specify a custom label.

For information about the settings on this panel, see [Label Panel on page 700](#).

## COMPONENTS PANEL

The information on the COMPONENTS panel can be used in the materials list. For more information, see [Components Panel on page 1330](#).

## OBJECT INFORMATION PANEL

The information entered on the OBJECT INFORMATION panel can be used in schedules and the materials list. For more information, see [Object Information Panel on page 1331](#).

## SCHEDULE PANEL

The settings on the SCHEDULE panel determine which schedule categories the selected object is included in. See [Schedule Panel on page 704](#).

---

# Fireplaces



A selection of freestanding fireplace symbols is available in the Architectural Core Catalog. See [The Library on page 945](#).



A masonry fireplace can be placed in or away from a wall by selecting the legacy **Fireplace** tool and then clicking in the drawing area.

- If created in a wall, it is considered a wall opening and can be moved or resized like a window or door.
- If created away from a wall, it moves and resizes similar to a cabinet.

The legacy **Fireplace**  tool can be added to the toolbars. See [Adding and Removing Buttons on page 132](#).

The display of fireplaces is controlled in the Layer Display Options dialog. See [Layer Display Options Dialog on page 179](#).

Fireplaces can be edited, moved, resized, and deleted similar other objects. See [Editing Objects on page 205](#).

## BUILT INTO A WALL

Flush and Mantle fireplace symbols are available in different styles in the Library Browser and can be positioned against a wall to create the front face of a built-in fireplace. For information about adding a chimney, see [Chimneys on page 728](#).

To place a masonry fireplace in a wall, click the **Fireplace**  button, then click on a wall. A fireplace is created with the outside of the fireplace flush with the outside of the wall.

Fireplaces cannot be placed in a wall specified as Invisible or if the wall in question is on a locked layer. See [Locking Layers on page 178](#).

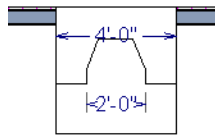

A selected masonry fireplace inserted into a wall has four edit handles, all located along the wall.

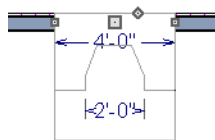

Click the diamond-shaped Depth handle and drag toward the outside of the wall. The fireplace will stop when the firebox front is flush with the inside edge of the wall.

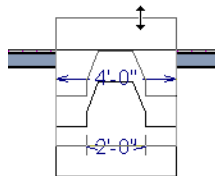

In 3D views, fireplaces placed in walls have five edit handles: a Resize handle along each edge and a Move handle at the center.

Fireplaces always face the interior when placed on an exterior wall. When placing a fireplace in an interior wall, click on the edge of the wall that you want the fireplace to face. The fireplace is created with the firebox on the same side as the wall edge you clicked on to create it.

### FREESTANDING FIREPLACES

A selection of freestanding metal and adobe fireplace unit symbols is available in the Library Browser.

To place a free-standing masonry fireplace, click the **Fireplace**  button, then click in an open area away from a wall.

Both fireplace symbols and freestanding legacy masonry fireplace objects have ten edit handles when selected and may be rotated, resized, or moved in any direction, similar to the way CAD boxes can. See [Editing Box-Based Objects on page 232](#).

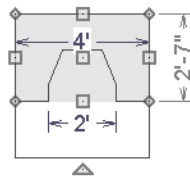

Free-standing fireplaces can be selected and replaced with a symbol from the library by clicking the **Replace From Library**  edit button. See [Replace From Library on page 976](#).

## MASONRY FIREPLACE FOUNDATIONS

When a Walls with Footings or Grade Beams on Piers foundation is built, a fireplace foundation will be generated under any **Fireplaces**  present on Floor 1. See *Building a Foundation on page 710*.

Fireplace foundations are the same material type as the original fireplace, but do not have a firebox or a hearth. Fireplace foundations can be edited or deleted as needed. A firebox and hearth can be added in the Fireplace Specification dialog. See *Fireplace Specification Dialog on page 726*.

# Fireplace Specification Dialog

Select a legacy Fireplace and click the **Open Object** edit button to display the Fireplace Specification dialog. Multiple fireplaces can be group-selected, but all objects in selection group must be either placed in a wall or free-standing.

## GENERAL PANEL

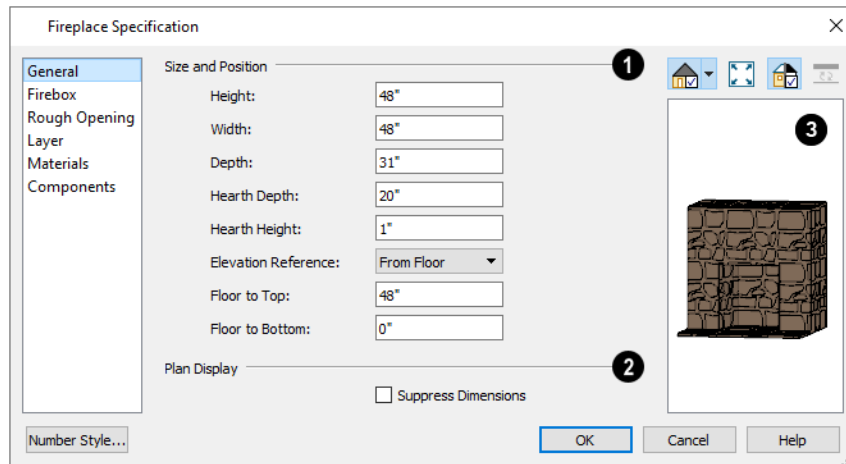

### 1 Size and Position

- Specify the **Height**, **Width**, and **Depth** of the fireplace.
- Specify the **Hearth Depth**. This is measured from the front of the fireplace out into the room. To eliminate the hearth altogether, enter a zero for this value.
- Specify the **Hearth Height**, relative to the floor in the room that the fireplace faces.
- Select the **Elevation Reference** from the drop-down list. This determines where the next two settings are measured from and also affects their setting labels.
- Specify the height **to Top**, measured from the selected Elevation Reference.
- Specify the height **to Bottom**, measured from the selected Elevation Reference.

## 2 Plan Display

Check **Suppress Dimensions** to turn off the display of the selected fireplace’s width and firebox width dimensions in floor plan view.

## 3 Preview

The preview of the fireplace updates as changes are made. See *Dialog Preview Panes on page 22*.

## FIREBOX PANEL

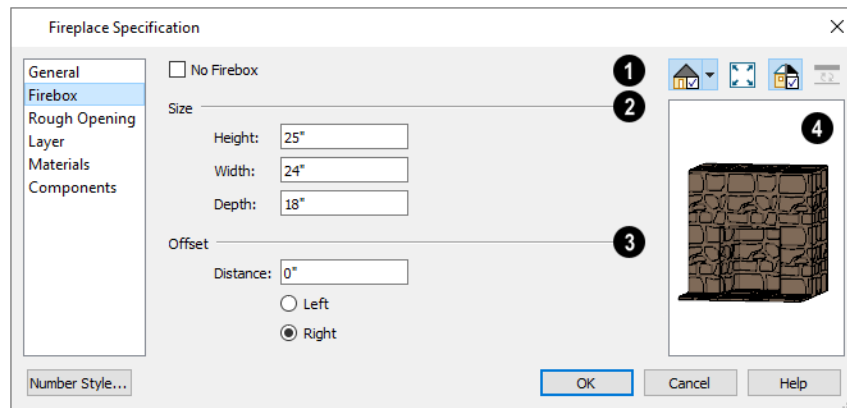

## 1 No Firebox

Check **No Firebox** to eliminate the firebox from the fireplace. This is checked by default for a fireplace object generated on Floor 0 to serve as a solid matching base for a fireplace on Floor 1.

## 2 Size

- Specify the firebox’s **Height** and **Width**.
- Specify the **Depth** of the firebox.

## 3 Offset

- Enter the offset **Distance**, which is how far the firebox is offset from the fireplace center. A value of 0 centers the firebox in the fireplace.
- **Offset to Left/Right** - Choose to offset the firebox to the left or to the right.

## 4 Preview

The preview of the fireplace updates as changes are made. See *Dialog Preview Panes on page 22*.

## ROUGH OPENING PANEL

The settings on the **ROUGH OPENING** panel are also found on the panel of the same name in the Door Specification dialog. See *Rough Opening Panel on page 572*.

## LAYER PANEL

For information about the settings on this panel, see *Layer Panel on page 186*.

## MATERIALS PANEL

For information about the settings on this panel, see [Materials Panel on page 1055](#).

## COMPONENTS PANEL

The information on the COMPONENTS panel can be used in the materials list. For more information, see [Components Panel on page 1330](#).

---

# Library Fireplaces

A variety of fireplace symbols are available in the library. Flush fireplaces are designed to snap to wall surfaces. Some fireplace symbols can be enclosed by walls or positioned to project through a wall. See [Placing Library Objects on page 972](#).

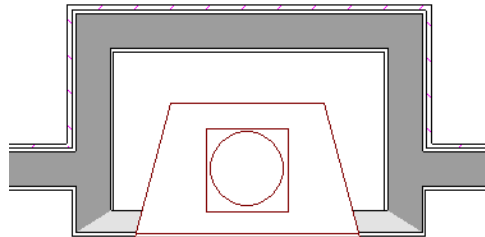

 Always check the manufacturer's product information for the framing and clearance requirements of the fireplace unit you plan to use, and design your plan accordingly

---

# Chimneys

Chimneys can be created using a variety of methods.

## MASONRY FIREPLACE CHIMNEYS

### *To create a chimney on a masonry fireplace*

1. Select the fireplace in a 3D view.
2. Ctrl + drag the top edge of the chimney upward through all the floors and the roof until it is to the desired height. See [Unrestricted Movement on page 244](#).
3. When the chimney is approximately the correct height, select the fireplace, click the **Open Object**  edit button, and type in the exact height.

## CHIMNEY CHASES AND CAPS

There are two ways to draw a chimney chase:

- Place a 3D Solid, closed box Geometric Shape, or Soffit over the chimney chase, resize it to match, then increase its height either in its specification dialog or in a 3D view using the same method as extending a masonry fireplace.



- Use walls to define the chimney chase as a room area, making sure these walls are aligned between floors. The chimney chase “room” on the uppermost floor should have a much higher ceiling than the other rooms on that floor and should also have no ceiling or roof. See *Room Specification Dialog on page 437*.

A selection of chimney tops is available in the library. In addition, custom chimney caps can be made using 3D Solids or other primitive objects, Geometric Shapes, and/or Soffits. See *Other Objects on page 1014*.

# Multiple Floors

## Chapter 21

When a new plan file is opened in Chief Architect Premier, two floor levels are present: Floor 1 and the Attic Floor. You can add more floors whenever you like: up to 30 total. Once created, floors can also be copied, swapped, and deleted.

Chief Architect also supports special floors for foundations and attics. Only one foundation level and one attic can exist in a plan. Foundations are discussed in their own chapter. See *Foundations on page 705*.



### TOPICS

<b>Floor Defaults Dialog</b> .....	<b>731</b>
<b>Floor Tools</b> .....	<b>731</b>
<b>Adding Floors</b> .....	<b>732</b>
<b>Displaying Floor Levels</b> .....	<b>734</b>
<b>Exchanging Floors</b> .....	<b>735</b>
<b>Copying Floors</b> .....	<b>735</b>
<b>Deleting Floors</b> .....	<b>735</b>
<b>Rebuilding Walls, Floors and Ceilings</b> .....	<b>735</b>
<b>Split Levels</b> .....	<b>736</b>
<b>The Current Floor</b> .....	<b>737</b>
<b>The Attic Floor</b> .....	<b>738</b>
<b>The Reference Display</b> .....	<b>738</b>

---

## Floor Defaults Dialog

 There is a Floor Defaults dialog for each floor in a plan file aside from the Attic floor, which can be accessed by selecting **Edit> Default Settings**. Click the arrow to the left of “Floors and Rooms” to expand the category, then expand the “Floor Levels” subcategory. Select one or more floor levels and click the **Edit** button to open the Floor Defaults dialog for that floor. See [Default Settings vs Preferences on page 77](#).

- Floor Defaults can also be accessed by double-clicking the **Floor Tools**  parent button.
- In addition, the **Floor Defaults**  button can be added to the toolbars. See [Toolbar Customization Dialog on page 134](#).

The Floor Defaults dialog also opens whenever you add a new floor to the plan. See [Adding Floors on page 732](#).

The Floor Defaults dialog does not open when you build a foundation; however, the **Floor 0 Default** settings are created based on the current Foundation Defaults. See [Foundation Defaults on page 706](#).

The Floor Defaults dialog is similar to the Room Specification dialog, but controls the default settings for all rooms on the floor in question. The settings here also control the height of individual walls as they are drawn on that floor. See [Room Specification Dialog on page 437](#).

Note: The default floor height for Floor 1 is 0. It can be modified in the Room Specification dialog, but not in the Floor 1 Defaults dialog. See [Floor and Room Defaults on page 413](#).

### STRUCTURE PANEL

The settings on the STRUCTURE panel are similar to those in the Room Specification dialog. See [Structure Panel on page 439](#).

### MOLDINGS PANEL

The settings on the MOLDINGS panel are similar to those in the Room Specification dialog. See [Moldings // Profiles / Rails / Panels on page 927](#).

### FILL STYLE PANEL

The settings on the FILL STYLE panel are similar to those in the specification dialogs for many objects throughout the program. See [Fill Style Panel and Dialogs on page 193](#).

### MATERIALS PANEL

The settings on the MATERIALS panel are similar to those in the specification dialogs for many objects throughout the program. See [Materials Panel on page 1055](#).

---

## Floor Tools

 Select **Build> Floor** to access the following floor tools:



**Build New Floor** builds a new floor; a new floor can be generated based upon the perimeter of the floor below or a blank floor can be created and drawn from scratch. See [Adding Floors on page 732](#).



**Insert New Floor** inserts a new floor below the Current Floor. See [Adding Floors on page 732](#).



**Delete Current Floor** removes the Current Floor from the plan. For more information, see [Deleting Floors on page 735](#).



**Exchange With Floor Above** moves the Current Floor up one floor and the floor above it down. See [Exchanging Floors on page 735](#).



**Exchange With Floor Below** moves the Current Floor down one floor and the floor below it, up. See [Exchanging Floors on page 735](#).



**Build Foundation** opens the Foundation Defaults dialog and build a foundation floor. See [Building a Foundation on page 710](#).



**Delete Foundation** removes the foundation from the plan. See [Deleting Foundations on page 716](#).



**Hole in Floor Platform** allows you to draw a hole in a floor platform on the Current Floor. See [Floor and Ceiling Platforms on page 428](#).



**Hole in Ceiling Platform** allows you to draw a hole in a ceiling platform on the Current Floor. See [Floor and Ceiling Platforms on page 428](#).



**Floor Material Region** allows you to create an area within a floor platform that uses different materials than the floor. See [Floor and Wall Material Regions on page 1037](#).



**Rebuild Walls/Floors/Ceilings** forces Chief Architect to recalculate the relationship between the walls, floors, and ceilings in your model. See [Rebuilding Walls, Floors and Ceilings on page 735](#).

## Adding Floors

When a new plan file is opened in Chief Architect Premier, two floor levels are present: Floor 1 and the Attic Floor. You can add up to 30 total living floors, as well as create a foundation below Floor 1.

Floors can be added whenever you like; and once created, they can also be copied, swapped, and deleted.

Note: Chief Architect allows only one floor, the foundation/basement, below Floor 1. See [Foundations on page 705](#).

### BUILD NEW FLOOR



New floors can be created in plan view as well as in 3D views, and are always added above the top living floor. To create a new floor, select **Build> Floor> Build New Floor**.

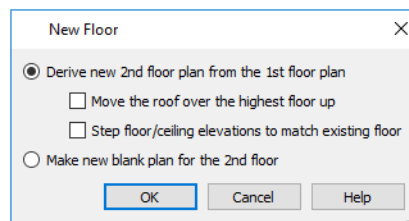

- **Derive new 2nd floor plan from the 1st floor plan** creates a new top floor with exterior walls generated directly over the exterior walls of the floor below. Wall types and roof directives associated with the walls on the floor below are duplicated; however, interior walls are not. See [Roof Panel on page 398](#).

- Check **Move Highest Floor’s Roof Up** to move any roof planes displaying on the highest floor in the plan up one floor when the new floor is created. Roof planes displaying on floors other than the top floor are unaffected. This option is only available if there are roof planes built on the top floor and is not available when **Auto Rebuild Roofs** is enabled. See *Build Roof Dialog on page 797*.



When Move highest floor roof up is checked, roof planes on the top floor will move even if the “Roof Planes” layer is locked and manually edited roof planes are set to be retained. See *Roof Panel on page 798*.

- Check **Step floor/ceiling elevations to match existing floor** to maintain all ceiling heights on the existing floor by stepping floor heights on the new floor to match. Ceiling heights on the new floor also become stepped accordingly. See *Floor and Ceiling Platforms on page 428*.
- **Make new (blank) plan for the # floor** creates a new top floor that is blank. This option is typically useful only if none of the exterior walls on the new floor will be directly above the exterior walls on the floor below. If you choose this method, it may be helpful to turn on the Reference Floor when drawing walls on the new floor. See *The Reference Display on page 738*.

When you click OK, the Floor Defaults dialog for the newly created floor opens. Make any necessary changes to the floor structure, moldings, or materials and click OK. See *Floor Defaults Dialog on page 731*.

The new floor becomes the Current Floor in plan view. If, however, the new floor is created in a 3D view, the camera remains on its original floor and does not move.

## INSERT NEW FLOOR



A floor level can also be inserted beneath the Current Floor in both plan and 3D views. Begin by going to the floor level you would like to insert a floor under to make it the Current Floor, then select **Build> Floor> Insert New Floor**. See *The Current Floor on page 737*.

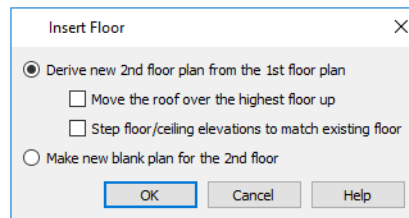

- Select **Derive new # Floor plan from the # Floor plan** to insert a new floor below the Current Floor, with exterior walls based on those of the Current Floor.
- Check **Move Highest Floor’s Roof Up** to move any roof planes displaying on the highest floor in the plan up one floor when the new floor is created. Roof planes displaying on floors other than the top floor are unaffected. This option is only available if there are roof planes built on the top floor and is not available when **Auto Rebuild Roofs** is enabled. See *Build Roof Dialog on page 797*.



When Move highest floor roof up is checked, roof planes on the top floor will move even if the “Roof Planes” layer is locked and manually edited roof planes are set to be retained. See *Roof Panel on page 798*.

- Check **Step floor/ceiling elevations to match existing floor** to maintain the floor and ceiling heights on the existing floors by stepping floor and ceiling heights on the new floor to match. See *Floor and Ceiling Platforms on page 428*.
- Select **Make new (blank) plan** to insert a blank floor below the Current Floor.

## ADDING A FOUNDATION

To add a foundation, select **Build> Floor> Build Foundation** . See [Building a Foundation on page 710](#).

---

# Displaying Floor Levels

Chief Architect allows you to view the floor levels in a plan in a variety of ways.

## IN PLAN VIEW

In plan view, only one floor level can be active for editing at a time. This is referred to as the Current Floor. See [The Current Floor on page 737](#).

In addition to the Current Floor, one or more other floors can be displayed for reference purposes: the Reference Floor. Objects on the Current Floor can snap to those on the Reference Floor, helping you align objects. See [The Reference Display on page 738](#).

Floor and ceiling platforms do not display in plan view. When floor and/or ceiling framing is present, its display can be turned on; however, other components of floor and ceiling platforms like sheathing, drywall, and finish materials, cannot.

## IN 3D VIEWS

In 3D views, all floor levels in a plan are visible, from the foundation up to the attic. There are two exceptions:



**Orthographic and Perspective Floor Overviews**, which show the Current Floor, not including its ceiling, plus any floors beneath it.



**Wall Elevation** views, which show a wall on a single floor, in a single room.

See [3D View Tools on page 1084](#).

## IN THE MATERIALS LIST

The materials that make up floor and ceiling platform assemblies are listed under different Categories in the Materials List:

- **Subfloor** - Lists floor framing and structural subflooring materials specified in all Floor Structure Definitions in the current plan. See [Floor and Ceiling Platform Definitions on page 429](#).
- **Flooring** - Lists flooring and subflooring materials specified in all Floor Finish Definitions in the current plan.
- **Framing** - Lists ceiling framing and any other materials specified in all Ceiling Structure Definitions in the current plan.
- **Wall Board** - Lists ceiling finish materials specified in all Ceiling Finish Definitions in the current plan.
- **Insulation** - Floor insulation is calculated for all rooms that have a floor, and ceiling insulation is calculated for all rooms that have a ceiling - regardless of the Floor or Ceiling Structure Definition. When a ceiling is not present, insulation is calculated for the roof. See [Structure Panel on page 439](#).
- **Foundation** - Lists the concrete and mesh for all Floor Structure Definitions in the current plan with a layer of concrete material. See [Materials and the Materials List on page 1063](#).

See [Materials Lists on page 1303](#).

---

## Exchanging Floors



Select **Build> Floor> Exchange With Floor Above** or **Exchange With Floor Below** to swap the Current Floor with the floor above or below.

The floor that was moved becomes the Current Floor at its new location. You can easily move a floor up or down several floors by using either one of these buttons repeatedly.

---

## Copying Floors

The **Edit Area**  tools can be used to make copies of entire floors in a plan. See [Edit Area Tools on page 269](#). You can use these tools to:

- Make a copy of an existing floor to be pasted onto a new floor.
- Make a copy of all existing floors in a plan to be pasted into a different plan.

You can also copy the information on a floor by pressing Ctrl + A (Select All), then using **Copy**  and **Paste Hold Position** . See [Paste Hold Position on page 171](#).

### COPYING BETWEEN PLANS

While you can copy and paste floors from one plan file to another, this is not always the best approach.

- To make a copy of the plan for backup or your records, use **Save As**  to save the file using a new name. See [Saving Plan and Layout Files on page 40](#).
- To copy the model into another plan with multiple structures, consider exporting it as a symbol and importing it into the new plan. See [Symbol Objects on page 978](#).

---

## Deleting Floors



Select **Build> Floor> Delete Current Floor** to remove the Current Floor from the plan. If there is a floor above, it becomes the Current Floor; if there is no floor below, the floor beneath becomes the Current Floor.



To delete Floor 0, select **Build> Floor> Delete Foundation**. You can delete the foundation without actually being on Floor 0. Floor 0 cannot be deleted while **Auto Rebuild Foundation** is turned on. See [Deleting Foundations on page 716](#).



When a floor is deleted, all objects on that floor are deleted with it, including locked roof planes and any other objects on locked layers. See [Locking Layers on page 178](#).

---

## Rebuilding Walls, Floors and Ceilings



When you make a change to the walls or to the floor or ceiling platforms in your plan, they may not immediately resize or move in the 3D model. The program does detect such changes, though, and the next time you generate a 3D

or section/elevation view, walls, floors and ceilings are rebuilt.

By default, walls, floors and ceilings are also rebuilt when an automatic roof is generated. See *Build Roof Dialog on page 797*.

You can direct the program to rebuild walls, floors, and ceilings at any time by selecting **Build> Floor> Rebuild Walls/Floors/Ceilings** .

If you do not want the program to rebuild walls, floors and ceilings when a 3D view is created, uncheck **Auto Rebuild Floors and Ceilings** in the 3D View Defaults dialog. This may speed up plan view editing for very large plans. When this is unchecked and the structure is not up-to-date, the **Rebuild Walls, Floors, Ceilings**  icon displays near your mouse pointer. See *3D View Defaults Dialog on page 1083*.

---

## Split Levels

Both split level floor plans and split level entries can be created by controlling the floor and ceiling heights of individual rooms in a multiple story structure.

For more detailed information about both types of structure, visit [chiefarchitect.com](http://chiefarchitect.com).

### SPLIT LEVEL FLOOR PLANS

A split level, or tri-level, structure is a building where the floor level in one part of the plan is located approximately halfway between the floor and ceiling levels of another part of the plan.

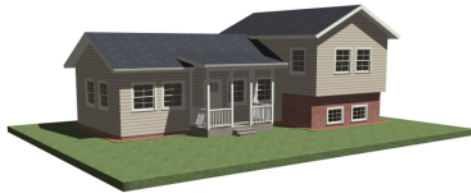

#### *To create a simple split level plan*

1. Draw a simple rectangular structure divided into two separate halves by an interior wall.
2. Select one of the rooms and click the **Open Object**  edit button. See *Room Specification Dialog on page 437*.
3. Raise the **Floor Height** then press the Tab key.
4. Restore the **Relative Rough Ceiling** to the default value, then click OK.
5. Build a stem wall foundation. See *Foundations on page 705*.
  - The foundation under the room with the lower floor height will have the specified Min Stem Wall Height.
  - The foundation under the room with the raised floor will have taller stem walls.
  - Both can be edited in the Room Specification dialog.
6. If you add a Floor 2, note that the **Ceiling Height** in the room on Floor 1 will be reset to the default value.
  - To maintain a stepped condition on multiple floors, return to this room and set the **Relative Rough Ceiling** back to using the default.



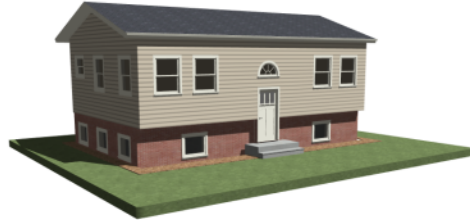

## SPLIT LEVEL ENTRIES

A split level entry, or divided entry, is characterized by an entry door that opens onto a landing positioned halfway between the basement floor and first floor levels.



### *To create a simple split level entry*

1. Create a plan file with a full basement at the location of the entry door. See [Basement Rooms on page 717](#).
2. Go to Floor 0 and draw a stair **Landing**  at the location of the entry. See [Landings on page 755](#).
3. Specify the desired height of the landing. See [Stair Landing Specification Dialog on page 787](#).
4. Draw stairs upward from the basement floor to the landing.
5. Draw a second stair section from the landing upward.
6. Select the stairs and click the **Auto Stairwell**  edit button. See [Creating a Stairwell on page 769](#).

Split level entries are often associated with daylight basements. See [Daylight Basements on page 718](#).

---

## The Current Floor

In a given plan view window, only one floor level can be active at any given time. The active floor is referred to as the **Current Floor**, and it is the only floor on which objects can be edited.

If you would like to view two different floor levels side by side, open a second plan view, navigate to the desired floor, and then tile the two views. Although both are visible, only one of these view windows is active. See [Working in Multiple Views on page 150](#).

## FLOOR UP / FLOOR DOWN



If you are working with more than one floor, you can select **Tools > Floor/Reference Display > Up One Floor** or **Down One Floor** to switch from one floor to another.

You can change the Current Floor in floor plan, cross section/elevation and 3D views. The Current Floor displays on the **Change Floor/Reference**  button, which can be found between the **Down One Floor** and the **Up One Floor** buttons.

Floors become available once they have been built. The Attic and foundation levels are also accessible using these tools.

## CHANGE FLOOR / REFERENCE

- 1 If there are multiple floors, select **Tools > Floor/Reference Display > Change Floor/Reference** to open the Change Floor/Reference dialog, where you can select both the Current Floor and which floor is used in the Reference Floor,

as well as control the appearance of the Reference Floor. See [The Reference Display on page 738](#).

---

## The Attic Floor

**A** Chief Architect automatically creates a floor above the top numbered floor level of each plan. This floor is called the Attic floor and has only one purpose: to provide a space for automatically generated Attic walls. See [Attic Walls on page 380](#).

In some situations, you may find it necessary to draw one or more walls on the Attic floor; however, even if you enclose an area with walls, rooms cannot be created on this floor level. If you wish to create an attic loft or bonus room in your plan, you must do so on a numbered floor level.

Because the Attic floor is not meant to be a living area, a warning message will display if you try to draw walls or other objects on this floor level.

---

## The Reference Display

Objects on the Current Floor can snap to objects on the Reference Floor; however, objects on the Reference Floor cannot be selected or edited.

The Reference Display allows you to show the positions of objects on a different floor or even in a different plan file in the current view. This allows you to confirm correct placement of objects; show an as-built structure in the same view as a remodel drawing; compare different options; and more. The Reference Display can be used in plan, camera, and cross section/elevation views.

### REFERENCING A FLOOR PLAN

In plan view, the Reference Display can show one or more Reference Floors from the current plan or from another plan file or files.

- By default, the current plan file is used, the Reference Floor is the floor below the Current Floor, and the Reference Display uses the “Reference Display Layer Set”.
- If you specify that the Reference Display refer to another plan file, it will show the same floor level as the current plan by default, if possible, and will use the “Reference Display Layer Set” as defined in that other plan file.

While the default “Reference Display Layer Set” is sufficient for most purposes, you can create additional reference layer sets and use any of them individually or in combination in the Reference Floor Display. See [Layer Set Management on page 184](#).

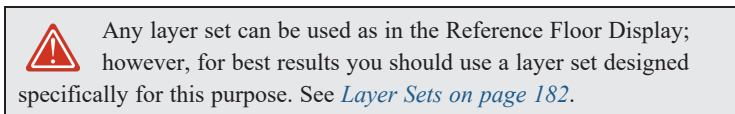

Reference Floor Display settings, including whether its display is toggled on, which floor level or levels are shown, and which layer set or sets it uses, are plan view specific and can be customized in the Saved Plan View Specification dialog. See [Layout Box Specification Dialog on page 1349](#).

These settings can also be customized in plan views sent to layout. See [Layout Box Specification Dialog on page 1349](#).

## REFERENCING A 3D MODEL

In camera and cross section/elevation views, the Reference Display can show objects from another plan file, as well as specify whether they are shown using Standard or Glass House Rendering.

In camera and cross section/elevation views, the default layer set for the current view type as set in the current plan is used. The actual layer set is saved in the referenced plan, and can be changed to use any other layer set saved in that plan. See *Layer Set Management on page 184*.

## CHANGE FLOOR / REFERENCE DIALOG

- 1 Select **Tools > Floor/Reference Display > Change Floor/Reference** or click the toolbar button that reports the current floor level. See *The Current Floor on page 737*.

In the Change Floor/Reference dialog, you can specify which floor level is the Current Floor. You can also specify a Reference Floor from one or more different plan files, multiple Reference Floors, and Reference Floor layer sets and drawing order here, as well.

When this dialog is accessed from a camera view, the Reference Display settings instead allow you to specify one or more referenced plan files, layer sets, and Rendering Techniques.

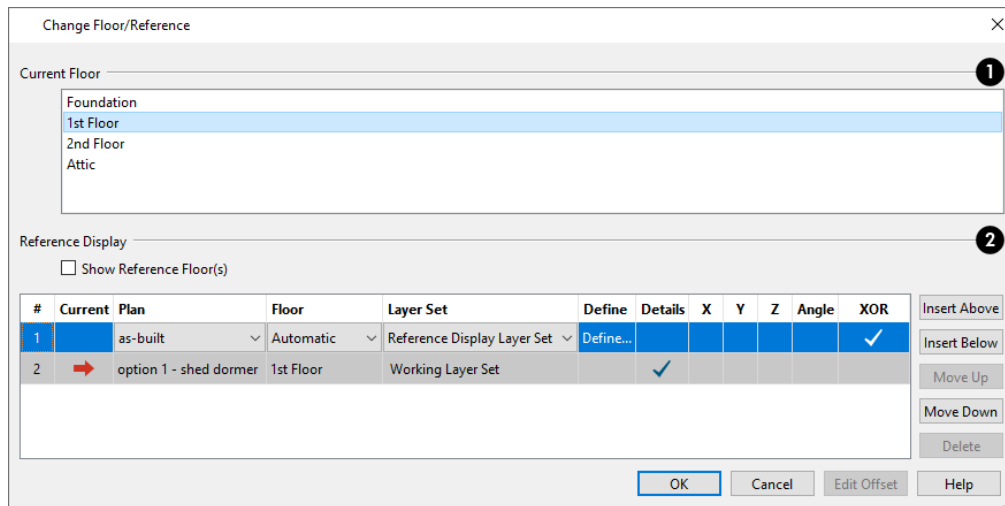

### 1 Current Floor

The **Current Floor** is highlighted here. Select another floor from the list to make it the Current Floor instead.

### 2 Reference Display

These settings control the display and appearance of the Reference Floor or Reference Model in the current plan, camera, or cross section/elevation view.

- Check **Show Reference Floor(s)** to turn on the Reference Floor Display in the current plan view. When a camera view is active, this option is instead **Show Reference Model(s)**.
- The table lists the Current Floor or Plan along with one or more Reference Floors or Models in the order that they are drawn. Line items at the top of the table are drawn in front of line items further down in the table.
- Click on a line item in the table to select and edit it. Items with an arrow on the right side are drop-down lists.

- In plan view, the **Current** column indicates which line item in the table is either the Current Floor, selected above, or the currently active plan file. In camera and cross section/elevation views it indicates which line item is the Current Plan. The Current line item's attributes cannot be edited in this table.
- In all views, you can select a **Plan** file to show in the Reference Display.
- In plan view, the default plan is the Current Plan; in camera and cross section/elevation views, a different plan must be selected for use as the Reference Model.
- All currently open plan files are listed in the drop-down list.
- Select "Choose Existing Plan" to choose any available plan file. If it is not currently open, it will be opened when you select it.
- In plan view only, specify which **Floor** level is associated with each line item.
- The floor levels in the drop-down list are listed in the order that they are drawn in plan view: The floor in row 1 is drawn on top of the floor in row 2, which is drawn on top of the floor in row 3, and so on. Drawing order can be edited using the buttons to the right of the table.
- When "Automatic" is selected, the floor level below the Current Floor is always used; if there is no floor below, the floor above is used instead. If you instead choose a specific floor level from the list, it will be used, regardless of which floor level is the Current Floor. Not available for camera or cross section/elevation views.
- When a plan other than the Current Plan is selected for reference, "Match Current" is the default option that ensures that the Current Plan and Reference Plan always show the same floor level.
- Specify which **Layer Set** each line item uses. See [Layer Sets on page 182](#).
- Click in the **Define** column to open the Layer Display Options dialog and edit the Layer Set assigned to the selected line item. Not an option for the Current Floor level or Current Plan.
- In camera views, specify which **Rendering Technique** each referenced plan uses. Select Standard, Glass House, Technical Illustration, or Vector View from the drop-down list. See [Rendering Techniques on page 1150](#).
- Click to place a check in the **Details** column and include fill patterns in the Reference Floor Display. When unchecked, only object edge lines are drawn. Details are always included in the Current Floor.
- When a different plan has been selected for a Reference Plan, you can:
  - Offset it along the **X**, **Y**, and **Z** axes to bring it into alignment with the Current Plan. See [3D Drafting on page 13](#).
  - Specify the Reference Plan's **Angle**. See Edit Reference Document Offset, below.
- **XOR** drawing changes the color of lines in the Reference Floor Display when they are drawn on top of lines on the Current Floor. If the lines have identical properties, they are not drawn at all. When this is unchecked, the Reference Display color does not change, and identical lines are not suppressed.

Use the buttons on the right to manage the list of Reference Floors in the table. New Reference Floors use the Automatic floor behavior and Reference Floor Layer Set by default.

- Click the **Insert Above** button to add a new Reference Floor directly above the selected line item.
- Click the **Insert Below** button to add a new Reference Floor directly below the selected line item.
- Click the **Move Up** button to move the selected line item up one place in the list and in the display order.
- Click the **Move Down** button to move the selected line item down one place in the list and in the display order.
- Click the **Delete** button to remove the selected Reference Floor from the list. Not available if only one Reference Floor is present in the list, or if the Current Floor is selected.

## EDIT REFERENCE DOCUMENT OFFSET



When a different plan has been specified for the Reference Display, you can select **Tools> Floor/Reference Display> Edit Reference Document Offset** to toggle on the display of a selection marquee around it. The marquee has two edit handles: Move, and Rotate. The Move handle lets you adjust the **X** and **Y** offset, while the Rotate handle allows you to change the **Angle**.

# Stairs, Ramps, and Landings

## Chapter 22

Staircases can be composed of one or more straight or curved stair sections, ramps, and landings. Stairs and ramps can be drawn, selected and edited in 2D and 3D views.

Starter treads can be defined, stair sections can be flared, treads can be wrapped, and curved sections can be turned into winders.

Landings can be created automatically or manually and their shape customized. You can edit an existing landing, or create a landing from a closed CAD polyline. Landing heights can be defined or you can let them automatically adjust as needed.

Stairwells can be created automatically or manually and can be seen in 3D views.

	Local building and fire authorities must be consulted for specific stair construction codes and access requirements.
---	--

### TOPICS

<b>Stair and Ramp Defaults</b> .....	743
<b>The Stair Tools</b> .....	743
<b>Anatomy of a Staircase</b> .....	745
<b>Drawing Stairs and Ramps</b> .....	746
<b>L- and U-Shaped Stairs</b> .....	747
<b>Displaying Stairs, Ramps, and Landings</b> .....	749
<b>Editing Stairs and Ramps</b> .....	750
<b>Stair and Ramp Sections and Subsections</b> .....	752
<b>Landings</b> .....	755
<b>Maintaining Tread Depth</b> .....	756
<b>Flared Stairs and Curved Treads</b> .....	757
<b>Starter Treads</b> .....	761
<b>Winders</b> .....	762
<b>Wrapped Stairs</b> .....	763
<b>Other Special Railings and Stairs</b> .....	765
<b>Creating a Stairwell</b> .....	769
<b>Rooms Below Staircases</b> .....	770
<b>Staircase Specification Dialog</b> .....	771
<b>Ramp Specification Dialog</b> .....	784
<b>Stair Landing Specification Dialog</b> .....	787

## Stair and Ramp Defaults



Default settings for stairs and ramps determine the initial attributes of these objects when they are first created.

Access the defaults by selecting **Edit> Default Settings**, then clicking the + beside **Stairs and Ramps**. Select an item and click the **Edit** button to open the defaults dialog associated with your selection. See [Default Settings vs Preferences on page 77](#).

The Stair and Ramp Defaults dialogs can also be accessed by double-clicking the **Stair Tools**  parent button or any child tool aside from the **Landing** tool.

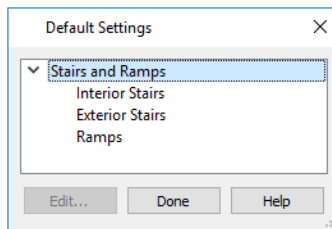

Both interior and exterior stairs have default definitions for size, style, materials and much more. In fact, the default dialogs for stairs and ramps are similar to the Staircase and Ramp Specification dialogs. See [Staircase Specification Dialog on page 771](#) and [Ramp Specification Dialog on page 784](#).

Interior and Exterior stairs are drawn using the same tools: stairs created inside a room are considered Interior while those drawn outside a structure are considered Exterior.

Landings do not have a defaults dialog. Instead, they get their initial attributes from the stairs or ramps that they are connected to.

### STRUCTURAL DEFAULTS

The purpose of interior stairs is to provide passage from one floor platform to another, so the attributes that influence floor heights - including ceiling heights, floor platform thicknesses, and floor finish materials - also influence the structure of stairs. When considering a staircase's structure, bear in mind that riser height is directly dependent on the distance from one floor platform to another.

When **Automatic Heights** are used, stairs are built so that they rest on the top of the floor structure of the floor where they are drawn, and build up to the top of the floor structure on the floor above. Risers are measured to the floor finish surfaces on both floors. See [Floor and Ceiling Platform Definitions on page 429](#).

Ramps are built in a similar manner: interior ramps bear on the floor structure, and when **Automatic Heights** are used, the top surface of both interior and exterior ramps locates floor finish surfaces.

## The Stair Tools



Select **Build> Stairs** to access the Stair Tools.

### DRAW STAIRS



To draw a straight staircase select **Build> Stairs> Draw Stairs**, then click and drag in floor plan or a 3D view. You can also click once to place a staircase that extends from the current floor up to the next floor. See [Drawing Stairs and Ramps on page 746](#).

## STRAIGHT STAIRS



Select **Build> Stairs> Straight Stairs**, then click to create stairs between the current floor and the floor above. To create stairs between two floor platforms on the current floor, click on the low side, within a few feet of where the floor changes height.

- If you click on the low side of a floor platform defined by a railing, a doorway will be created in the railing, adjacent to the stairs.
- If you click on the low side of a floor platform defined by a wall, stairs will be created but a doorway will not.
- If you click at a location that is not near the edge of a floor platform, a full height staircase will be created.

## CURVED STAIRS



Select **Build> Stairs> Curve to Left** or **Curve to Right** and click once in plan view to place a curved staircase. See *Curved Stairs and Ramps on page 746*.

## L-SHAPED STAIRS



Select **Build> Stairs> L-Shaped Stairs**, then click to create two equal stair sections that form a 90° corner and are connected by a landing. See *L- and U-Shaped Stairs on page 747*.

## U-SHAPED STAIRS



Select **Build> Stairs> U-Shaped Stairs**, then click to create two stair sections that form a 180° turn and are connected by a landing.

## LANDING



Select **Build> Stairs> Landing** to draw a landing, which is a platform connecting two or more stair sections. See *Landings on page 755*.

There are two ways to create a landing using this tool:

- Click once to place a landing measuring 39" (975 mm) on each side.
- Click and drag to draw a rectangular landing sized as needed. See *Polylines on page 316*.

You can also create a landing by converting a CAD polyline. See *Convert Polyline on page 262*.

## RAMP



Select **Build> Stairs> Ramp** to draw a sloped ramp. By default, ramps are drawn at a 1:12 slope to a maximum height of 30" (760 mm). See *Drawing Stairs and Ramps on page 746*.

## SPIRAL STAIRS



In the Library Browser, browse to Chief Architect Core Catalogs> Architectural> Spiral Stairs to access a selection of spiral staircase fixtures. Select the object that you want, then click in any view to place it in the plan. See *The Library on page 945*.

Because spiral staircase symbols are fixture symbols, they do not have an Auto Stairwell edit tool. An opening in the floor above a spiral staircase must be created manually. See *Creating a Stairwell on page 769*.



---

## Anatomy of a Staircase

Stairs as well as ramps are often described in terms of **rise** and **run**. Rise is typically between 6" and 8", and the run between 10" and 12". In metric plans, rise is 177 to 190 mm, and the run is about 250 mm. Whenever possible, Chief Architect will automatically apply reasonable rise and run values that meet most building codes to stairs and ramps as they are drawn.

In Chief Architect, staircases automatically have a consistent rise and run along their length because this is also a typical requirement of most building codes. When this is not desired, however, stairs and ramps can be divided into multiple sections subsections. See *Stair and Ramp Sections and Subsections on page 752*.

### STAIRCASE TERMINOLOGY

**Balusters** - The vertical members that run between the handrail and the treads or bottom rail.

**Bracket** - Decorative L-shaped supports on the exposed side of stairs below each tread.

**Landing** - A platform connecting two or more stair sections.

**Newels** - The end post of a stair railing located at landings and the beginnings and endings of new stair sections.

**Rise** - The height of a riser, measured from tread surface to tread surface, Also referred to as Unit Rise.

**Rise Angle** - The angle of the staircase or stair section, defined by a line drawn through the back surfaces of its treads.

**Riser** - The vertical stair member located between the treads. Risers may be solid or open. When open, the front surfaces of the stringers are considered the risers.

**Run** - The depth of a tread, measured from riser surface to riser surface. Run does not include the Tread Overhang. Also referred to as Unit Run.

**Runner** - The carpet that runs down the center of the staircase.

**Shoe** - The bottom railing, placed on the landing floor, that anchors the balusters at landings.

**Stringer** - The inclined support member of a staircase that supports the treads and risers.

**Tread** - The horizontal member of a stair that the foot is placed on.

**Tread Overhang** - The portion of a tread extending past the front surface of the riser and over the tread below. Also referred to as Nosing or Nosing Extension, it is not included in the Run or Tread Depth measurements.

**Tread Thickness** - The vertical depth of the tread material.

**Winder** - A wedge-shaped stair tread used where curved or angled stairways change direction.

### STAIR STRUCTURE AND THE MODEL

By default, stairs locate the height of the floor platform that they are drawn on and seek the next level, which may be the floor platform of the floor above or a landing. The stringers locate the subfloor of the floor platforms and maintain consistent riser height. If the stairs are long enough to reach the next level at a reasonable rise angle, their tread depth and number of treads are automatically calculated to create a staircase with consistent tread and riser dimensions along its entire length.

You can modify this behavior or turn off it off altogether in the Staircase Specification dialog and specify your own rise and run values. Bear in mind, though, that if you turn it off, you will need to specify the correct **Top and Bottom Heights** to make sure that the stairs actually meet both floor platforms correctly. See *General Panel on page 771*.

---

## Drawing Stairs and Ramps

Stairs and ramps can be drawn in floor plan and 3D views but not in cross section/elevation views. There are a few things to keep in mind when drawing stairs:

- Before stairs are created, make sure that the heights for both the lower and upper floors are correctly defined.
- Stairs are drawn going **UP**, so they should be drawn from the lower of the two floors they connect.
- By default, stairs adjust their riser and tread dimensions to connect two floor heights if possible. The rise and run are calculated so that the steps are consistent in size.
- Stairs drawn within 1" (25 mm) of a wall will snap to the outer surface of the wall.
- Stairs will snap to the **Reference Display** , if you have it turned on. See [The Reference Display on page 738](#).
- Hold down the Ctrl key to suppress these snapping behaviors.
- If a stairwell room has been defined on the floor above, the top of the stairs can be dragged until it stops at the railing or wall defining the stairwell.
- When drawing stairs or a ramp up from the terrain, it is a good idea to make sure the terrain is up-to-date. See [Building the Terrain on page 1256](#).

### STRAIGHT STAIRS AND RAMPS

The **Draw Stairs**  tool can be used in two different ways:

- Click and drag in a straight line to draw stairs that are the length that you drag.
- Click once to place stairs that go from the current floor up to the height of the next floor level.

You can also click once using the **Straight Stairs**  tool to create stairs between rooms on the same floor with different floor heights or between exterior rooms and the terrain. When the Straight Stairs tool is active, a preview outline of the stairs will follow the mouse pointer. Hold down the Alt key to reverse the direction of the Up arrow in the preview.

Similarly, **Ramps**  can be created by either clicking and dragging or by clicking. A ramp created with a single click will be 30" (760 mm) high, have a slope of 1:12, and be 360" (9120 mm) long.

An individual stair or ramp section must be between 6" (150 mm) and 100' (30 m) in length. If a greater length is needed, connect two sections using a landing.

### CURVED STAIRS AND RAMPS

You can make a straight stair or ramp section curved, or vice versa:

- Select the stairs or ramp and click the **Change Line/Arc**  edit button. See [Change Line/Arc on page 256](#).
- Select the stairs or ramp, hold down the Alt key (or right-click), and drag an end edit handle. See [Alternate on page 207](#).

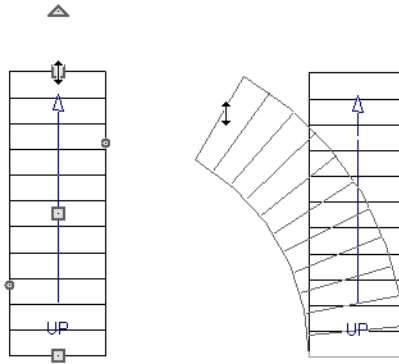

You can also curve straight stairs and ramps by drawing them against a curved wall.

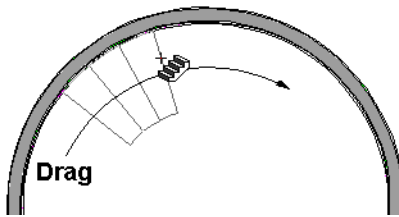

 **Curved Stairs** can also be created in plan view by selecting **Build> Stairs> Curve to Left** or **Curve to Right**. Click to place a 90° curved stair section that can then be edited. You can continue clicking to place additional curved staircases until another tool is selected.

Once drawn, the radius of a curved stair section can be specified in the Staircase Specification dialog. See [General Panel on page 771](#).

## DRAWING STAIRS AND RAMPS DOWNWARD

Stairs and ramps can be drawn from the current floor level downward; however, drawing stairs or ramps between floors in this manner is not recommended. Drawing downward should only be used to create a staircase or ramp between a porch or deck and the terrain when you require the direction arrow to say “DN” instead of “UP”. See [Displaying Stairs, Ramps, and Landings on page 749](#).



### *To draw stairs going downward*

1. Select **Build> Stairs> Draw Stairs** .
2. Hold down the Alt key or the right mouse button.
3. Click and drag to create straight stairs.

When drawing stairs or ramps from a floor platform to the terrain, or vice versa, they will locate the height of the terrain as long as it is lower than the floor height. You can also create a landing or “room” outside the structure and use it to establish the bottom height of the stairs or ramp. Then, draw in an upward direction from the lower platform to the upper platform.

---

## L- and U-Shaped Stairs

  The **L-Shaped Stairs** and **U-Shaped Stairs** tools allow you to place staircases composed of two stair sections connected by one or more landings with a single click.

The staircases created with these tools build from the current floor to the floor above. If you need a staircase that builds between platforms on the same floor level, or in a downward direction, you will need to draw it manually. See [Landings on page 755](#).

When you select either tool, the New Shaped Staircase dialog opens.

## NEW SHAPED STAIRCASE DIALOG

The settings in this dialog retained between sessions in the software and are global, affecting all plans.

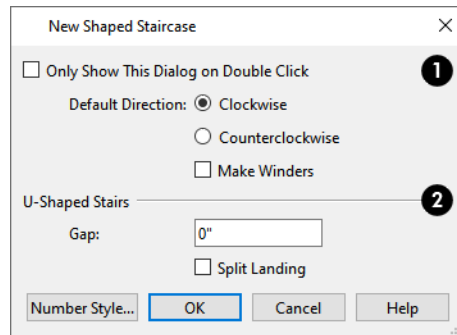

1

- Check **Only Show This Dialog on Double Click** to suppress this dialog unless the L-Shaped Stairs or U-Shaped Stairs is double-clicked.
- Specify the **Default Direction** of the stairs as they build upward: **Clockwise**, or **Counterclockwise**. These settings only apply to staircases when they are not placed next to a wall.
- Check **Make Winders** to create multiple landings with angled edges between the two stair sections. When unchecked, a single rectangular landing is produced.

2

### U-Shaped Stairs

- Specify the width of the **Gap** between the two stair sections.
- Check **Split Landing** to create two rectangular landings instead of one. When Make Winders is also checked, each of these two landings is further divided into triangular shaped winders.

When you click OK, a preview outline will follow the mouse pointer.

## PLACING L- AND U-SHAPED STAIRS

You can control the staircase's orientation and direction prior to placing it by moving the mouse pointer towards a wall.



In the case of a **L-Shaped**  staircase with **Clockwise** set as the Default Direction:

- As you move the mouse pointer close to a wall, the upper stair section in the preview outline will snap to the wall first.
- As you move the mouse pointer closer to the wall, the preview outline will rotate so that the bottom stair section snaps to the wall instead.
- If you move the mouse pointer into a wall corner, the preview outline will rotate so the landing is in the corner and the Default Direction is used.

In the case of a **U-Shaped**  staircase with **Clockwise** set as the Default Direction:

- As you move the mouse pointer close to a wall, the back of the landing in the preview outline will snap to the wall first.
- As you move the mouse pointer closer to the wall, the preview outline will rotate so that the upper stair section snaps to the wall.
- If you continue to move the mouse closer, the lower stair section will snap to the wall instead.
- If you move the mouse pointer into a wall corner, the preview outline will rotate so that the bottom stair section snaps to the wall that is nearest to the mouse pointer.

When an L- or U-Shaped Staircase preview outline is in a wall corner, you can use the mouse to further control position and direction:

- When an **L-Shaped**  staircase preview is in a wall corner, move the mouse pointer over the stair sections to control which is the bottom section.
- When a **U-Shaped**  staircase preview is in a wall corner, move the mouse pointer within the landing area to control which wall the back of the landing snaps to.
- With the landing in place, move the mouse pointer over the two stair sections to control which is the bottom section.

You can use keyboard hotkeys to override these behaviors:

- Press the Alt key to reverse these snapping behaviors and the stairs' direction.
- Hold down the Ctrl key to prevent the stairs from rotating or snapping to walls.

---

## Displaying Stairs, Ramps, and Landings



The display of stairs, ramps, and landings in all views is controlled in the Layer Display Options dialog. Stairs, ramps, and landings are placed on the “Stairs & Ramps” layer by default but, once created, can be placed on any layer. See [Layer Attributes on page 177](#).

### IN PLAN VIEW

In plan view, stairs, ramps and landings display on the floor they were drawn on and are only visible from the floor above if there is a stairwell. See [Creating a Stairwell on page 769](#).

Stairs and ramps have an arrow indicating the direction they run. Interior stairs and ramps have an **UP** arrow on the floor they were created on and a **DN** arrow when viewed from the floor above. See [Drawing Stairs and Ramps on page 746](#).

The style and size of the direction arrow can be specified in the Staircase or Ramp Specification dialog. The Text Style, color, and display are controlled by the “Stairs & Ramps, Up/Down Arrows” layer. See [Arrowheads on page 327](#).

In addition, staircases can use and display a Walk Line in plan views. The **Walk Line** is drawn on the same layer as its staircase and can be specified in the Staircase Specification dialog. See [Style Panel on page 774](#).

Stair landings can also display labels in plan and cross section/elevation views when the “Polylines 3D, Labels” layer is turned on. Landings do not have an automatic label; however, you can specify a custom label in the Landing Specification dialog. See [Label Panel on page 700](#).

You can specify whether newels, balusters, and/or rails display in plan view in the Staircase Specification dialog. See [Newels/Balusters Panel on page 781](#).

The display of stair and ramp overhangs and tread nosing in plan view can be controlled using the “Stairs & Ramps, Details” layer. The display of stair stringers in plan view is controlled using the “Stairs & Ramps, Stringers” layer.

You can create custom labels for stairs, ramps, and landings using the Text Tools and custom text macros. See [Creating User Defined Macros on page 1387](#).

When a staircase is selected in plan view, the numbers associated with each of its sections and subsections display. Stair sections are assigned a single number, while subsection numbers have two parts: a section number and subsection number separated by a hyphen.

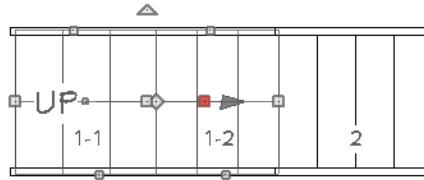

To see the center of a stair section curve in plan view, click **Show Arc Centers and Ends** . See [Arc Centers and Ends on page 223](#).

## ON MULTIPLE FLOORS

Stairs and ramps display on the floor level on which they are drawn. If they are located beneath an Open Below room, they will be visible within the area of that room on the floor level above, as well.

To display exterior stairs on multiple floors, you can create a custom Reference Display Layer Set with just the stairs in question set to display. See [The Reference Display on page 738](#).

## STAIR BREAKLINES

In plan view, staircases can display a breakline symbol. The portion of the staircase located above the breakline can display as either a dashed outline with transparency or it can be suppressed altogether. See [Breakline Panel on page 778](#).

A breakline can be added to a selected staircase in either of two ways:

- Click the **Add Breakline**  edit button.
- Check **Has Breakline** in the Staircase Specification dialog.

A breakline's position along the staircase can be adjusted using the small, circular Move Breakline edit handle that displays along the breakline, as well as in the Staircase Specification dialog.

To remove a breakline from a staircase, click the **Remove Breakline**  edit button or uncheck **Has Breakline**.

## IN 3D VIEWS

Although stairs span between two floors, they can only belong to one floor. As a result, only multi-floor views show the upper floor with the platform opening and the lower floor with the staircase simultaneously. In Floor Overviews, stairwells may appear as an empty spaces. See [3D View Tools on page 1084](#).

---



# Editing Stairs and Ramps

Staircases and ramps can be selected and edited in plan view and 3D views. See [Selecting Objects on page 210](#).

To select a single section of a staircase, hold down the Shift key before clicking on it. When selected in this manner, a stair section can be edited independent of any other connected stair sections.

## USING THE EDIT HANDLES

When a staircase or ramp is selected, its edit handles display. These edit handles can be used to customize the selected object in many ways. See *Editing Objects on page 205*.

- Straight stair sections and ramps are edited along their centerlines like CAD lines. They have additional edit handles for resizing the width of the section. See *Editing Line-Based Objects on page 216*.
- Curved stair sections and ramps are edited along their centerlines like CAD arcs and also include edit handles for resizing the stair's width. See *Editing Arc-Based Objects on page 219*.
- Ramps can be resized to a maximum top height of 30" (760 mm). If you extend a ramp's length to greater than 360" (9120 mm), its slope will decrease. For a taller ramp and control over the slope, uncheck **Automatic Heights** in the Ramp Specification dialog and specify the values you need. See *General Panel on page 785*.
- When stair sections are merged, the edit handles display differently depending on what subsection is currently selected. See *Merging Stair and Ramp Sections on page 753*.
- When moving merged stair or ramp sections, all merged sections and landings move as one unless **Stair Sections Move Independently** is checked in the Preferences dialog. To temporarily enable this behavior, hold down the Alt key on the keyboard. See *Architectural Panel on page 113* and *Alternate on page 207*.
- Additional edit handles display on the first two treads of a staircase if the **Starter Tread**  edit button is clicked. See *Starter Treads on page 761*.
- Several additional edit handles display on a staircase if the **Flare/Curve Stairs**  edit button has been clicked. See *Flared Stairs and Curved Treads on page 757*.

## IN THE SPECIFICATION DIALOG

 Stairs and ramps can be customized and their structure precisely defined in the Staircase and Ramp Specification dialogs. See *Staircase Specification Dialog on page 771*, *Ramp Specification Dialog on page 784*, and *Stair Landing Specification Dialog on page 787*.

Stair, ramp, and landing railings can also be customized. See *Railing Panel on page 779*, *Newels/Balusters Panel on page 781*, and *Rails Panel on page 783*.

## USING THE EDIT TOOLS

A selected staircase or ramp can be edited in a variety of ways using the buttons on the Edit Toolbar. See *The Edit Toolbar on page 130*.



**Starter Tread** allows you to create one or two rounded starter treads at the base of a selected staircase. See *Starter Treads on page 761*.



**Flare/Curve Stairs** allow you to flare or curve the sides of the selected staircase's base. See *Flared Stairs and Curved Treads on page 757*.



**Add Stair Breakline** adds a breakline to the selected staircase while **Remove Stair Breakline** removes it. See *Stair Breaklines on page 750*.



**Auto Stairwell** creates a Stairwell room on the floor above the selected staircase. See *Creating a Stairwell on page 769*.

## ADJUSTING THE RADIUS OF CURVED STAIRS

The easiest way to match the radius of a stair section to the radius of a curved wall is to draw a staircase near one side of the curved wall using the **Draw Stairs**  tool. The stairs snap to the wall, and the radius of the new staircase is defined. See [Curved Stairs and Ramps on page 746](#).

Existing curved stairs can be aligned with an existing curved wall by aligning their centers, much the same way that curved stairs on different floors can be aligned. See [Aligning Objects on page 246](#).

If there is no curved wall, the radius of a stair section can be aligned to a CAD arc or circle.

### *To align curved stairs to an object*

1. Align the centers of the CAD object and the staircase.
2. Select the curved stairs and move the side nearest to the arc or circle edge using the **Resize** edit handle.

Finally, restore the stair width by dragging from the other side handle or using the Stair Specification dialog.

---

## Stair and Ramp Sections and Subsections

In Chief Architect, staircases and ramps can be composed of multiple sections. In addition, each section can be broken into multiple subsections.

- Both sections and subsections can be curved while their neighbors are straight and can have different tread depths.
- Stair sections can also have different tread widths, can be disconnected from adjacent sections using the edit handles, and are usually separated from other sections by landings.
- Subsections both move and rotate as a single object, while sections move with other sections but rotate separately.

You can identify sections and subsections by clicking on a stair or ramp to select it: sections are identified with labels using whole numbers (1, 2, etc), while subsections are identified using hyphens (1-1, 1-2, etc). In addition, when a stair or ramp is selected, only the selected section will have edit handles.

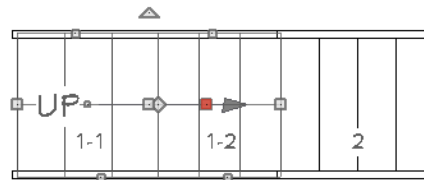

The selected section or subsection can be identified by the Move edit handle, which is red by default. See [Selected Edge on page 212](#).

## CREATING STAIR AND RAMP SUBSECTIONS



There are several ways to create a stair section with multiple subsections:

- Draw one section, then draw a second section that begins at the first one's endpoint.
- Draw two separate segments, then snap the start point of one segment to the endpoint of the other using the edit handles.
- Draw one segment and use the **Add Break**  edit tool to divide it into two subsections. See [Add Break on page 254](#).



## CREATING STAIR AND RAMP SECTIONS

There are also three ways to create multiple stair sections:

- Draw two separate stair sections and join them using a landing.
- Use the **Complete Break**  edit tool to divide a section into two sections. See [To create a complete break on page 255](#).
- Use the **Disconnect Selected Subsection**  edit tool to change a subsection into a section.

## MERGING STAIR AND RAMP SECTIONS

Any combination of straight and curved stair sections or straight and curved ramps using **Automatic Heights** can be merged. The resulting staircase or ramp section is made up of subsections and, if there are no landings, functions as a single unit.

Stair and ramp subsections must be drawn in the same direction if they are to be merged:

- The top edge of a stair section or ramp cannot merge with the bottom edge of another section or ramp.
- Combinations of stairs drawn in the **UP** and **DOWN** directions cannot be merged.

Stair subsections merge at the center points of their upper and lower edges.

Stair sections and ramps cannot be merged directly. If a combination of stairs and a ramp is required, connect them with a landing. See [Landings on page 755](#).

### *To merge stair or ramp sections*

1. Confirm that the stairs or ramps that you wish to merge are using **Automatic Heights**. See [General Panel on page 771](#).
2. Position the sections so they are in the desired relationship to each other.
  - In order to merge stair sections correctly, they must be parallel to one another.
  - To create merged subsections that change direction, make one of the merged sections curved and then specify Winders. See [Winders on page 762](#).
3. Select either stair or ramp section so that its edit handles display.
4. Click the Extend handle on the end to be merged and drag it to the point where the two stairs or ramps are to meet.

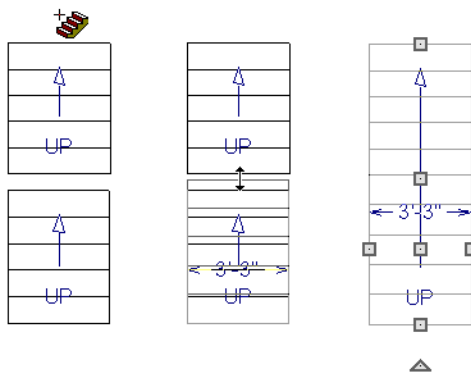

A staircase consisting of merged subsections resembles a single stair section in plan view. The **UP** (or **DN**) arrows join, becoming a single direction arrow.

When a subsection is selected, the entire staircase is selected. Additional edit handles, indicating the presence of multiple subsections and allowing you to reposition the line along which they join. See [Using the Edit Handles on page 751](#).

## LOCK TREAD DEPTH

If a staircase with **Lock Tread Depth** selected in the Staircase Specification dialog is resized, its length increases or decreases one full tread at a time. See [General Panel on page 771](#).

When **Lock Tread Depth** is checked, it can be difficult to merge the section with another section or landing. If this is a problem, you can temporarily uncheck **Lock Tread Depth**. After the stairs are merged, the tread depth can be locked again.

## CURVED SUBSECTIONS

Stair subsections attached at both ends by other sections do not have a free end that can be dragged into a curve. In this situation, change the middle sub-section to a curve using the **Change Line/Arc**  edit button. See [Change Line/Arc on page 256](#).

### *To curve an enclosed stair subsection*

1. Draw three straight stair sections and connect them end to end.
2. Select the middle subsection.

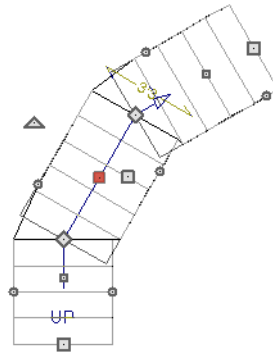

3. Click the **Change Line/Arc**  edit button. The center section turns into a curved stair section.

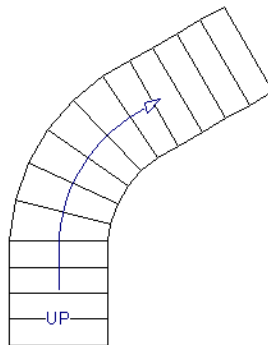





4. Use the triangular Change Curve edit handle to adjust the curvature of the middle section as needed.

Stairs joined in this manner can be turned into winders, which are steps located where a staircase turns and are narrower on the inside of the turn than they are on the outside. See [Winders on page 762](#).

## Landings

Stair landings are platforms between stair sections and/or ramps, and can be created in either of five ways:

- Click and drag using the **Landing**  tool.
- Single-click using the **Landing**  tool to create a 3'-3" (975 mm) square landing.
- Click between two stair sections using the **Draw Stairs**  tool.
- Convert a closed CAD polyline into a landing. See [Convert Polyline on page 262](#).
- One or more landings are also created when the **L-Shaped Stairs**  or **U-Shaped Stairs**  tool is used.

### To create a landing between stair sections

1. Draw two stair sections going UP. They can be at any angle.
2. Click between the two sections using the **Draw Stairs**  tool to create a landing. Notice that only one direction arrow displays after the sections are joined by a landing.

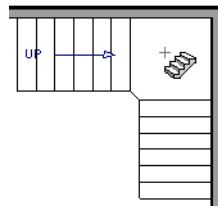

Similarly, a landing can be created between two ramps by clicking between them with the **Ramp**  tool active.

Multiple stair sections and/or ramps can be connected to one landing. For example, two or three stair sections might meet at a landing with a single stair section continuing to the next level.

To be linked by a landing, all sections must be drawn in the same **UP** direction and the top of one section should be near the bottom of the next.

Stair sections connected with a landing will move together as a single unit unless **Stair Sections Move Independently** is checked in the Preferences dialog. See [Architectural Panel on page 113](#).

A landing formed between two stair sections having less than a 90° angle between them are created with a short edge not less than 6" (150 mm). This is because most building codes require the shortest tread to be at least 6" wide. This edge can be manually edited to less than 6" if needed.

### ADJACENT LANDINGS

Some staircases have more than one landing adjacent to one another. When **Auto Adjust Height** is used, landings in Chief Architect recognize other nearby landings and will automatically adjust their heights and railings when their edges are sufficiently close to one another.

To create adjacent landings, draw two landings and then position them so that their edges are within 1" (25 mm) of one another. The landing that was drawn first will maintain its position while the height of the one drawn later will be the equivalent of one riser higher than the first. The railings on adjacent edges are suppressed, as well.

Adjacent landings can be used to represent winders. See [Winders on page 762](#).

## EDITING LANDINGS

Once created, landings can be selected in 2D and 3D views and edited like other closed-polyline based objects. See [Editing Closed Polyline-Based Objects on page 228](#).

Landings derive their initial materials, height, thickness, and railings from the stairs and/or ramps attached to them. You can assign a unique railing or material to a landing in the Stair Landing Specification dialog. See [Stair Landing Specification Dialog on page 787](#).

When moving a landing, all stair or ramp sections connected to it move as one unless **Stair Sections Move Independently** is checked in the Preferences dialog. To temporarily enable this behavior, hold down the Alt key on the keyboard. See [Architectural Panel on page 113](#) and [Alternate on page 207](#).

## LANDING HEIGHT AND THICKNESS



A landing's height and thickness can either be dynamically controlled by the program or user-defined and static.

By default, landing top height and thickness are both set to **Auto Adjust**. This means that if the structure of the attached stairs is edited so that their length or riser height is affected, the landing's height and thickness will adjust automatically to maintain consistent riser height in all connected stair sections.

If you uncheck either **Auto Adjust** box in the Stair Landing Specification dialog, the landing will maintain the specified height and/or thickness no matter how the attached stairs or ramps are modified. This can result in stairs that have inconsistent risers. See [General Panel on page 788](#).

## LANDING RAILINGS

By default, landings have railings on all edges, but will automatically suppress the railing along any portion of an edge that connects to a stair or ramp section or has an adjacent landing. You can specify whether this automatic behavior is used, the railing is suppressed, or the railing is always applied in the Stair Landing Specification dialog. See [General Panel on page 788](#).

You can also suppress the railing on a selected edge by clicking the **Remove Railing from Selected Edge**  edit button. To always generate the railing on a selected edge, click the **Add Railing to Selected Edge**  edit button. See [Selected Edge on page 212](#).

Landings can be edited into a wide variety of shapes. So that the railings of stair sections connect properly to the landing railings, you may find it helpful to use the **Add Break**  edit tool to create a break in a landing edge if it is longer than the connecting stairs are wide. See [Add Break on page 254](#).

---

# Maintaining Tread Depth

Most building codes require staircases to maintain a consistent tread depth.

## WALK LINE

By default, Chief Architect measures a stair section's length and tread depth along a Walk Line located 12" (30 cm) from the right edge of the stair section. On curved stairs, it is located 12" (30 cm) from the inside edge of the curve.

The distance of the Walk Line from the staircase edge can be specified in the Staircase Specification dialog. See [Style Panel on page 774](#).

Alternatively, you can turn the Walk Line feature off and tread depth will be measured at the tread center.

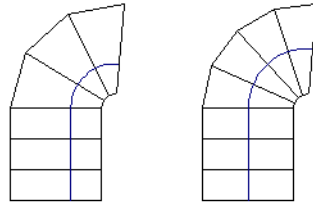

When a curved stair section has **Automatic Treads** specified in the Staircase Specification dialog and the Walk Line is used, the number and/or width of treads in a section or subsection changes when the inner edge is moved. For this reason, it is best to finalize stair section width as early as possible.

There are two ways to keep tread depth even throughout a stair section made of multiple subsections.

### LOCK TREAD DEPTH

The first way to maintain tread depth is to **Lock Tread Depth** to a specified value in the Staircase Specification dialog. See [General Panel on page 771](#).

Once locked, any changes to the length of the stair section are achieved by keeping the specified tread depth and changing the number of treads.

### IGNORE SUBSECTION BOUNDARIES

Curved stair sections typically have treads that are wider on one side than on the other. When they are connected to other stair sections, as with winders, it is possible to have treads that are too narrow at the Walk Line. See [Winders on page 762](#).

Uniform tread depth in a stair section with subsections can be maintained by checking **Ignore Subsection Boundaries** in the Staircase Specification dialog. See [General Panel on page 771](#).

When **Ignore Subsection Boundaries** is checked, the Tread Depth value may change when the stair section is edited, but will remain consistent throughout all subsections.

Because the boundaries between stair sections are being ignored, the treads where a straight section joins a curved section may shift position or change angle to accommodate the adjustment.

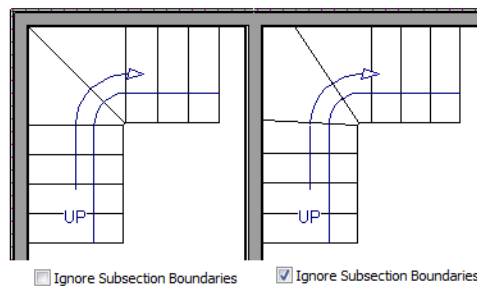

---

## Flared Stairs and Curved Treads



Any stair section can be flared and/or its treads curved using the **Flare/Curve Stairs** edit button.

Only exposed sides of a stair section can be flared. If one side of a stair section is against a wall or wrapped (see [Wrapped Stairs on page 763](#)), only the exposed end can be flared.

 Flaring, curved treads, and special treads should be the last changes that you make to any stairs.

## CREATING A FLARED STAIR

Flared stairs grow wider near one end, typically sweeping outward at the bottom. Stairs can also be flared at the top or on both ends.



### *To create flared stairs*

1. Create the stairs and connect them to a landing, floor platform edge, or another stair section.
2. Specify the section width, tread depth, and any other needed information.
3. Select the stairs and click the **Flare/Curve Stairs**  edit button. New **Flare** edit handles display on all four corners of the stairs.
4. Drag one of the corner handles to flare that corner. As you drag the flare, the Status Bar shows the distance the side handle moves. This allows you to move the opposite handle the same amount.

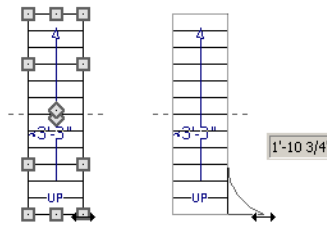

5. When you are finished editing the flare, click the **Main Edit Mode**  to restore the stairs' regular edit handles and toolbar buttons.

## SYMMETRICALLY FLARED STAIRS

Use the dimension information that displays in the Status Bar as a reference to create symmetric flares on both sides.

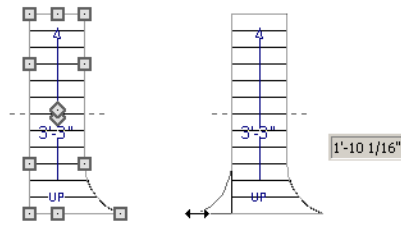

## ADJUSTING THE FLARE RADIUS

After a flared staircase has been created, you may want to soften the radius of the flare.

The four handles at the sides and the four handles at the corners flare the stair section when dragged outward. The two handles in the center of the section move the starting point for flaring along the stair section.

### *To adjust the flare radius*

First, adjust the curvature of the flared section.

1. Select the flared stair and click the **Flare/Curve Stairs**  edit button to access the flare handles again.
2. Select the handle along the flared edge of the stair. Drag this handle outward very slightly. This forms a more gradual flare.

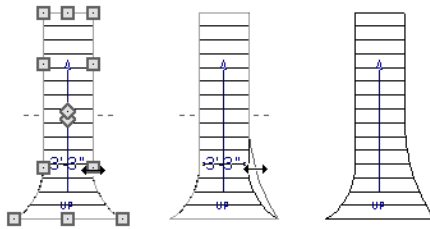

Then, adjust the starting point of the flare:

1. Select the flared stair and click the **Flare/Curve Stairs**  edit button to access the flare handles again.
2. This time, drag the lower of the two central handles upward. The handle above it moves with it. This moves the start point for the bottom flare from the middle of the section toward its top, making the flare even more gradual.

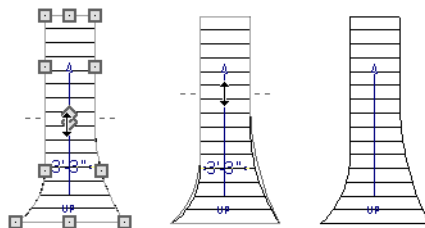

## TREADS PERPENDICULAR TO FLARE

Flared stairs often look best when the treads curve to meet the flared side perpendicular to the radius.

***To curve the edges of flared treads***

1. Select the flared stair and click the **Flare/Curve Stairs**  edit button to access the flare handles again.
2. Drag a corner edit handle upward one tread depth or less.

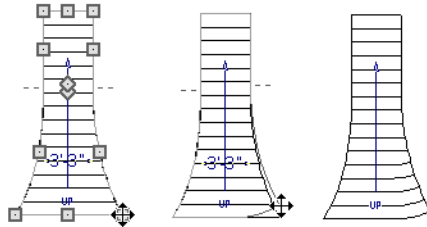

3. When you are finished editing the curve, click the **Main Edit Mode**  to restore the stairs' regular edit handles and toolbar buttons.

This type of tread curving works only on flared edges and concentrates the curvature at that edge.

Flared treads can also be curved using the Curve edit handle, which curves the treads more uniformly.

**CURVING THE TREADS**

When treads are curved, all treads in the section show some degree of curvature. Treads close to the curved end have a greater curve than those at the opposite end, but both ends can be curved.



***To curve stair treads***

1. Select the staircase, then click the **Flare/Curve Stairs**  edit button.
2. Drag the edit handle at the center of the bottom edge a small distance to curve the treads.



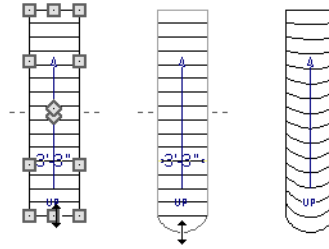

3. When you are finished editing the curve, click the **Main Edit Mode**  to restore the stairs' regular edit handles and toolbar buttons.

---

## Starter Treads



The first and second treads of a staircase can be turned into starter treads by clicking the **Starter Tread** edit button. Starter treads extend to the side of the staircase, have rounded edges and are common on traditional staircases.

A starter tread can be added only to open sides of a stair section. If one side of a stair section is against a wall or wrapped (see *Wrapped Stairs on page 763*), only the exposed tread end can become a starter tread.



### *To create starter treads*

1. Click on a staircase to select it.
2. Click the **Starter Tread**  edit button. An edit handle displays on each end of both the first and second treads.

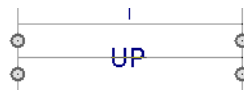

3. Drag either of the handles on the first tread outward from the stair section. If the stair section is against a wall, only one handle displays on the side opposite the wall.
4. As you drag, the ends of the tread become rounded.

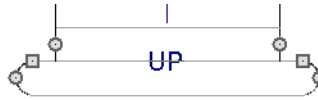

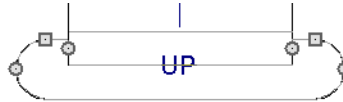

5. Two additional edit handles display on each side of the tread, along the back edge.
6. Drag either of the two square handles upward to increase the width of the rounded ends of the tread.

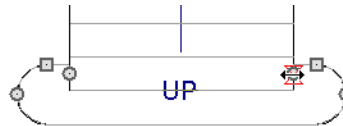

7. Drag the edit handle on the second tread outward from the stair section to create a second starter tread.



8. To make changes to existing starter treads, select the stairs, click the **Starter Tread**  edit button and repeat the above steps as needed.
9. When you are finished editing the starter treads, click the **Main Edit Mode**  to restore the stairs' regular edit handles and toolbar buttons.

## Winders

Winders are steps located where a staircase turns and are narrower on the inside of the turn than they are on the outside. A staircase defined as a winder expands to fill in any gaps between the side of the stairs and nearby walls.

Curved stair sections are typically used to create winders, although straight stairs can also be used. See *Curved Stairs and Ramps on page 746*.

### To create winders

1. In an enclosed room area, place and connect the stair sections that you want to be winders. For best results:
  - The stairs should be two straight sections connected by a curved section between them;
  - The curved section should be adjacent to a 90° corner, as illustrated.

 It is often easiest to create the staircase configuration in an open space, away from walls, then move it into position in a wall corner before specifying it as Winders.

2. Select the staircase and click the **Open Object**  edit button to open the Staircase Specification dialog.
3. On the GENERAL panel, place a check in the **Winders** check box and click **OK**.
  - The stairs should be two straight sections connected by a curved section between them;
  - The curved section should be adjacent to a 90° corner, as illustrated.



It is often easiest to create the staircase configuration in an open space, away from walls, then move it into position in a wall corner before specifying it as Winders.

4. Select the staircase and click the **Open Object**  edit button to open the Staircase Specification dialog.
5. On the GENERAL panel, place a check in the **Winders** check box and click **OK**.

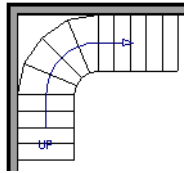

6. The steps nearest the wall corner adjust their shapes and extend into the corner after the stair is changed to a winder.



Winders must be in a room with valid room definition. You cannot create winders in an area composed of only 2 corner walls. If this configuration is needed, enclose the area in with Invisible walls so that a room area is defined.

The Winders attribute directs the stair section to expand or contract to meet nearby walls, and can also be used to create a partial railing. See [Partial Railings on page 766](#).

Winders sometimes have treads that are too narrow at the inside curve. The **Ignore Subsection Boundaries** option can address this issue. See [Ignore Subsection Boundaries on page 757](#).

In situations where the conditions for stair winders cannot be met, you can use adjacent landings. See [Landings on page 755](#).

---

## Wrapped Stairs

Check **Allow Wrap** on the STYLE panel of the Staircase Specification dialog and the selected stairs can be wrapped around the corner of a deck or landing. Curved stairs and stairs with multiple subsections cannot be wrapped. See [Style Panel on page 774](#).

Stair sections that wrap around a corner to meet one another must have identical attributes. As a result, edits made to one wrapped stair section apply to all adjacent, wrapped sections.

### *To wrap stairs around a deck*

1. Begin by drawing a deck. See [Decks on page 425](#).
2. Use the **Straight Stairs**  tool to place a stair section on each side of the corner around which you want them to wrap.
3. Move the stair sections toward the corner of the deck. When the two sections are sufficiently close to the corner,

they will merge to form wrapped steps.



 You can also draw stairs down from a deck by right-clicking to draw them or by pressing the Alt key while you drag. See [To draw stairs going downward on page 747](#).

***To wrap stairs around a landing***

1. Use the **Draw Stairs**  tool to create two perpendicular stair sections with top ends that share a corner.
2. Click between them to create a landing.
3. Rotate one stair section 180°.

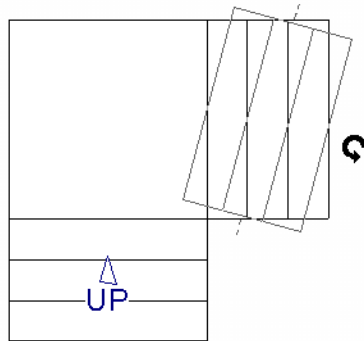

4. The stairs wrap around the corner. Notice that the Up arrow displays on the most recently edited stair section.

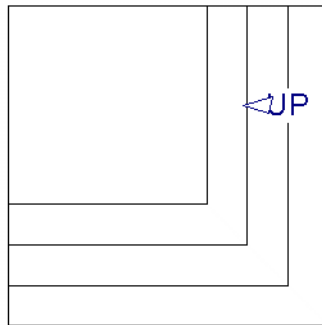

---

## Other Special Railings and Stairs

Stairs can be customized to meet a variety of needs.

### SOLID RAILINGS

-  To create a solid rail along a staircase, position a solid Railing against, but not underneath, the stairs. Specify it as **Solid** and that it **Follow Stairs**. See *Rail Style Panel on page 407*.

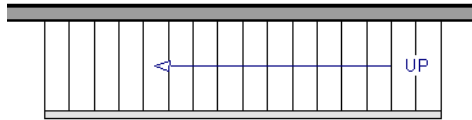

The solid railing recognizes the adjacent stairs and climbs alongside them.



If any balusters extend beyond the railing, eliminate them by unchecking **Left Railing** or **Right Railing** in the Staircase Specification dialog. See *Style Panel on page 774*.



### FULLY HOUSED STRINGERS WITH BALUSTERS

Fully housed stringers with balusters can also be created by positioning a pony wall next to the stairs.



#### *To create fully housed stringers*

1. Create a staircase, then select the stairs and click the **Open Object**  edit button.
2. On the **STYLE** panel of the Staircase Specification dialog, uncheck **Stringer at Wall** and click OK.

3. Draw an **Interior Wall**  or **Half Wall**  against, but not underneath, the stairs.
4. Select the wall and click the **Open Object**  edit button.
5. On the GENERAL panel of the Wall or Railing Specification dialog, make sure **Railing** is checked.
6. On the WALL TYPES panel:
  - Check **Pony Wall**.
  - Specify the **Lower Wall Type** as the same interior wall as the upper wall.
  - Specify the **Elevation of Lower Wall Top**. This value should equal the stairs' riser height plus the height above the treads.
7. On the RAIL STYLE panel:
  - Check **Follow Stairs**.
  - Specify desired **Railing Height**.
  - Click OK.

Note: To create housed stringers, check Trim Against Wall in the Staircase Specification dialog. See *Stringers Panel on page 776*.





## PARTIAL RAILINGS

A staircase can be enclosed on one side by a combination of wall and railing.



Partial railings can be created by creating a staircase composed of two sections, each with a different tread width. See *Stair and Ramp Sections and Subsections on page 752*.

### *To create a partial stair railing*

1. Create a staircase and draw an **Interior Wall**  against, but not underneath, the stairs.
2. In plan view, select the stairs and click the **Add Break**  edit button. See *Add Break on page 254*.
3. Next, click the **Complete Break**  edit button.
4. With **Object Snaps**  enabled, click once on the stairs where they meet the end of the interior wall to add a complete break to the stairs at that location. The staircase is broken into two separate sections. See *Object Snaps on page 160*.

5. Select the stair section that is not adjacent to the interior wall and, using either its edit handles or its specification dialog, increase its tread width.

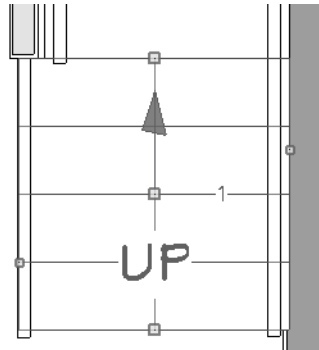

6. You may need to **Zoom**  in on the stairs and wall to move the stair edge.



## RAILING PANELS

You can specify panels, including glass panels or cables, as a stair or ramp's railing in the Staircase and Ramp Specification dialogs. See [Railing Panel on page 779](#).

## INSET OR MIDDLE RAILING

You can use a **Railing**  to create inset stair railings or a middle railing.

### *To use railing panels with stairs*

1. Create a staircase and draw a **Railing**  under the stairs.
  - Make sure that the railing is located entirely within a single stair section.
  - Position it so that it is aligned with the left edge.
2. Select the railing and click the **Open Object**  edit button. See [Wall Specification Dialog on page 392](#).
3. On the RAIL STYLE panel of the Railing Specification dialog:
  - Select the **Panels** radio button.
  - Check **Follow Stairs**.
4. On the NEWELS/BALUSTERS panel, click the **Browse** button to the right of **Panel Type** and select the railing panel you want to use on the stairs, then click OK.
5. Select the staircase and click the **Open Object**  edit button.
6. On the NEWELS/BALUSTERS panel of the Railing Specification dialog, uncheck **Left Railing** to prevent the default stair railing from generating in addition to the railing panel.
7. Repeat these steps if you want railing panels under the right side of the stairs, as well.

## CONCRETE STAIRS



### *To make a solid concrete staircase*

1. Select the stairs and click the **Open Object**  edit button.
2. On the STYLE panel of the Staircase Specification dialog:
  - Set the **Tread Overhang** to zero.
  - Set the **Tread Thickness** to zero.
  - Uncheck **Open Risers**.
  - Uncheck **Open Underneath**.
3. On the STRINGERS panel, you can also check **Large Stringer Base**.
4. On the MATERIALS panel, specify the “Riser/Trim”, “Support Wall”, and “Tread” materials as concrete.

## MASONRY STAIRS



### *To make a set of masonry stairs*

1. On the STYLE panel of the Staircase Specification dialog:
  - Set the **Tread Overhang** to zero.
  - Set the **Tread Thickness** to the thickness of the masonry material.
2. On the MATERIALS panel, assign the desired masonry material to the “Tread” component and specify the “Riser/Trim” material as concrete.

## STEEL STRINGER

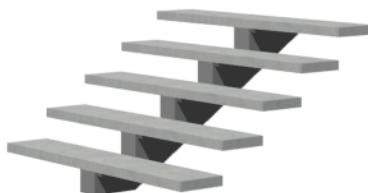



### ***To make a steel stringer with concrete treads***

1. On the STYLE panel of the Staircase Specification dialog:
  - Check **Open Underneath**.
  - Set the **Tread Thickness** to 2 inches or more.
2. On the STRINGERS panel, select **1 Center Stringer**.
3. On the MATERIALS panel, specify the “Tread” material as concrete and the “Riser/Trim” material as steel.

---

## **Creating a Stairwell**

An interior staircase must be located in a stairwell, an opening to the floor above. A stairwell is an Open Below room type on the floor above. See *Room Types and Functions on page 415*.

If you create a stairwell away from other walls so the Open Below is created in the center of another room, connect a wall of the Open Below room to another wall using an invisible wall.

### **CREATING A STAIRWELL AUTOMATICALLY**



 To create a stairwell that matches the perimeter of a selected staircase, click the **Auto Stairwell** edit button. This button is only available when a living space exists above the staircase. It will not be available if the space above is Open Below or on the Attic Floor.

**Auto Stairwell** automatically creates a room on the floor above enclosed by railings, defined as **Open Below** in the Room Specification dialog, and given a **Stairwell** room label. This room can be selected and edited like any other room.

### **CREATING A STAIRWELL MANUALLY**



Stairwells can also be created manually.

#### ***To create a manual stairwell***

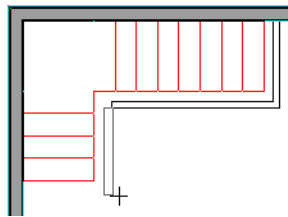
1. Draw a two-story building. Create the staircase on the first floor.
2. Make the second floor the **Current Floor** and the first floor the **Reference Floor**. See *The Reference Display on page 738*.
3. Select **Tools> Floor/Reference Display> Reference Display**  to show the Reference Floor, including the stairs.
4. On the upper floor, use the **Railing**  tool to create a room around the stairs. Use the edit handles to position the railings as needed.



5. Select the railings one at a time and move them into position.

- When a railing is selected, its bounding box shows the location of the outer surface of the railing’s drywall layer. For best results, this outer surface (which does not display when the railing is not selected) should meet the top edge of the stairs. See *Wall Types and Railings on page 350*.
  - If you prefer, you can also go **Down One Floor**  and adjust the top edge of the staircase to snap it to the surface of the railing on the floor above.
6. When the railings are positioned properly, select **Tools> Floor/Reference Display> Reference Display**  to turn off the display of the Reference Floor.
  7. Click inside the room using the **Select Objects**  tool to select it, then click the **Open Object**  edit button.
  8. On the GENERAL panel of the Room Specification dialog, select “Open Below” from the **Room Type** list. Click **OK** to close the dialog.

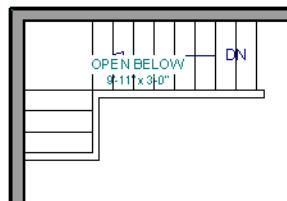

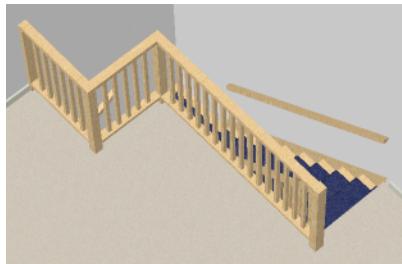

9. Place a **Doorway**  in the railing at the top step for an opening.
10. Select the doorway and define a large width in the Door Specification dialog. If the doorway is specified wider than the railing, its width adjusts to fit the available space.



## Rooms Below Staircases

Rooms such as closets or storage areas are commonly located beneath staircases.

### *To create a room below a staircase*

1. Draw a staircase, select it, and click the **Open Object**  edit button to open the Staircase Specification dialog. See *Staircase Specification Dialog on page 771*.
  - If Winders are specified for this staircase, set **Max Tread Contraction** to 2" on the STYLE panel to allow walls to be built entirely under the staircase.
  - On the FILL STYLE panel, select “No Pattern” so the walls and other objects under the stairs can be seen.
2. On the same floor as the staircase, draw the **Interior Walls**  under them, following their shape.
3. Reposition the walls as needed, making sure that each is entirely under the stairs.

4. The wall at the foot of the stairs should be placed no closer to the bottom than the second step.
5. Add a door and specify the Room Type.

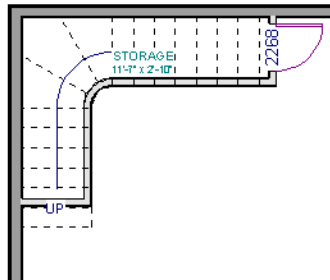

## Staircase Specification Dialog

Staircases can be defined with the greatest accuracy in the Staircase Specification dialog. To open this dialog, select one or more staircases and click the Open Object edit button, or double-click a stair section using the **Draw Stairs**, **Straight Stairs**, or **Select Objects** tool.

If a staircase is composed of multiple stair sections, the section that you clicked on to select the staircase is the Selected Section; however, information about all the sections is available and can be edited in the dialog.

The settings in the Staircase Specification dialog are similar to those in the Interior and Exterior Stair Defaults dialogs, but affect the selected staircase only. See *Stair and Ramp Defaults on page 743*.

The Staircase Specification dialog has the following panels:

 It is recommended that all floor heights, ceiling heights and platform thicknesses be established before using the Staircase Specification dialog.

### GENERAL PANEL

**Staircase Information**

Steep staircase reaches next level.  
 Best fit riser height of 6 3/4" requires 18 total risers to reach 121 3/4" to next level.

Number of Sections: 3  
 Number of Landings: 2  
 Number of Risers: 17  
 Rise Angle: 33.64

**Advanced Options**

Tread Depth:  
 Automatic Treads  
 Lock Tread Depth  
 Lock Number of Treads  
 Ignore Subsection Boundaries

Section Heights:  
 Automatic Heights  
 Top Height Reference:  
 Floor/Landing  
 Top Tread

Lock End:  
 Lock Top  
 Lock Bottom

Radius Reference:  
 Outer Arc  
 Center Line  
 Walk Line  
 Inner Arc

Section Number	Length	Width	Tread Depth	Treads	Bottom Height	Top Height	Riser Height	Radius	Winders
<input checked="" type="radio"/> 1	64 9/16"	39"	10 3/4"	6	7/8"	51"	7 3/16"	96 5/8"	<input type="checkbox"/>
<input type="radio"/> 2	57"	39"	11 3/8"	5	51"	94"	7 3/16"		<input type="checkbox"/>
<input type="radio"/> 3	32"	39"	10 11/16"	3	94"	122 5/8"	7 3/16"		<input type="checkbox"/>

Number Style...

## 1 Staircase Information

Structural information about the selected staircase displays here for reference and updates as changes are made on the GENERAL panel.

- The first comment tells whether or not the staircase reaches the next level, which may be a floor platform or locked landing. It also indicates whether its rise angle is either steeper or more shallow than the Best Fit, described below. If **Automatic Heights** is unchecked, this comment instead says “Start and end heights are set manually”.
- The second comment, **Best fit riser height of \_\_\_ requires \_\_\_ total risers to reach \_\_\_ to next level**, describes the ideal rise and run for the selected staircase. The program defines the Best Fit Riser Height as the riser height closest to 6 3/4” (168.75 mm) that allows the selected staircase to meet the next level precisely. This comment is only active if **Automatic Heights** is checked, below.

If the staircase includes a landing with a user-specified height, that height is used to calculate this information. See [Landing Height and Thickness on page 756](#).

- The total number of stair **Sections**, **Landings**, and **Risers** associated with the selected staircase also display here.
- The **Rise Angle** of the currently active stair section also displays here.
- Click the **Make Best Fit** button to add or remove risers to the Selected Section. Only available when **Automatic Heights** is checked and the staircase does not currently use the Best Fit Riser Height.

**Make Best Fit** will also extend stairs drawn in a downward direction until they reach the terrain. See [Terrain Perimeter on page 1244](#).

A diagram of a sample staircase’s structure displays here for reference, as well.

## 2 Advanced Options

The **Advanced Options** apply to all sections and subsections.

- Specify how **Tread Depth** is determined:
  - Select **Automatic Treads** to have the program define the depth and number of stair treads. If the staircase has multiple sections, each may have different tread depths.
  - Select **Lock Tread Depth** to specify the Tread Depth for each stair section, below, and prevent them from changing. When Lock Tread Depth is selected and the length of the stairs is changed, the number of treads will change.
  - Select **Lock Number of Treads** to specify the number of treads in each stair section and prevent it from changing. When Lock Number of Treads is selected and the length of the stairs is changed, the tread depths will change.
  - If multiple staircases or a staircase with multiple sections is selected, **No Change** may be an option as well. Select this to maintain the multiple sections’ individual settings.
  - Check **Ignore Subsection Boundaries** to maintain tread depth throughout a stair section composed of merged subsections, regardless of whether the subsections have different tread depths assigned to them. See [Ignore Subsection Boundaries on page 757](#).

- The **Section Heights** settings control how the top and bottom heights of each stair section is determined:
  - Uncheck **Automatic Heights** if you would like to specify the bottom and top heights of each stair section, as measured from the default floor height of Floor 1, 0” (mm). When checked, the program automatically defines the top and bottom heights by precisely locating floor platforms and landings. This option cannot be disabled in the Interior and Exterior Stair Defaults dialogs.
  - The **Top Height Reference** values control what point on the staircase the Top Height value, below, describes.
- Select **Floor/Landing** for the Top Height value to describe the height of the top tread plus the stated Riser Height.
- Select **Top Riser** for the Top Height value to describe the height of the top riser.
  - If you make changes in this dialog that will affect the Selected Section's length, first use the **Lock End** settings to control which end moves. The height of the Selected Section’s locked end is not affected by these settings: only its position in plan view. These settings are actions rather than settings and are not available in the Stair Defaults dialogs:
    - Select **Lock Top** to prevent the selected stair section’s top end from moving. Sections and landings above the selected section do not move when you click OK, while those below do move.
    - Select **Lock Bottom** to prevent the selected stair section’s bottom end from moving. Sections and landings below the selected section do not move when you click OK, while those above do move.

 If you select a staircase by clicking near its bottom end, Lock Top will be selected; if you select it near its top end, Lock Bottom will be selected.

- The **Radius Reference** options control where the radius of curved stair sections, specified below, is measured from.
  - **Outer Arc** measures the radius from the outer surface of the curved stair section's structure.
  - **Centerline** measures the radius from the curved stair section's centerline.
  - **Walkline** measures the radius from the curved stair section's walkline. See [Walk Line on page 756](#).
  - **Inner Arc** measures the radius from the inner surface of the curved stair section's structure.

### 3 Specifications

The specifications for each stair section and subsection are listed as line items and can be edited here. Up to ten line items total can display. A change in one value usually affects other values. You may need to reposition the staircase after making changes.

- The **Section Number** column identifies the Selected Section and the number of each section of the selected staircase. If **Ignore Subsection Boundaries** is unchecked, subsection numbers are also identified. The radio button to the left indicates which section or subsection is selected. See [Displaying Stairs, Ramps, and Landings on page 749](#).
- Define the **Length**, or run, of each section or subsection measured along the Walk Line. The length is equal to the number of treads multiplied by the tread depth. See [Walk Line on page 756](#).

When the length of a section changes, other sections and landings in the staircase unit move in response. You can specify whether the bottom or top edge of the Selected Section moves when you resize it by selecting either the Lock Bottom or Lock Top radio button, above.

- Define the **Width** of each section. Only one width can be defined for a section, so all subsections in the same section have the same width. If a section is connected to a landing, its width should equal the length of the landing edge that it connects to. See [Landings on page 755](#).
- Specify the **Tread Depth**, or run, of each stair tread in the selected section. To lock this value, check **Lock Tread Depth**, above.

If a landing is created between two stair sections and one of them has locked tread depth, the resulting staircase also has locked tread depth. Any landings or sections connected to this new staircase adjust to meet it and then have locked tread depth as well.

- Define the number of **Treads** in a stair section or subsection. To lock this value, select Lock Number of Treads, above.
- Define the **Bottom Height**, the height of the stair section’s bottom edge. To lock this value, click the radio button to the left of the section’s number, then click the Lock Bottom radio button, above, and click OK.
- Define the **Top Height**, the height of the stair section’s top edge. To lock this value, click the radio button to the left of the section’s number, then click the Lock Top radio button, above, and click OK.
- Define the **Riser Height**, the height of the risers in each stair section.
- Define the **Radius** of a curved stair section. The location on the stairs where the radius is measured from can be specified above. Not available if the selected staircase does not have a curved section.
- Check **Winders** to specify the Selected Section, including subsections, as winders. See [Winders on page 762](#).

#### 4 Preview

A preview of the selected staircase displays on the right side of the panel. If the staircase includes any landings, only the section that was selected when the dialog was opened will display. See [Dialog Preview Panes on page 22](#).

### STYLE PANEL

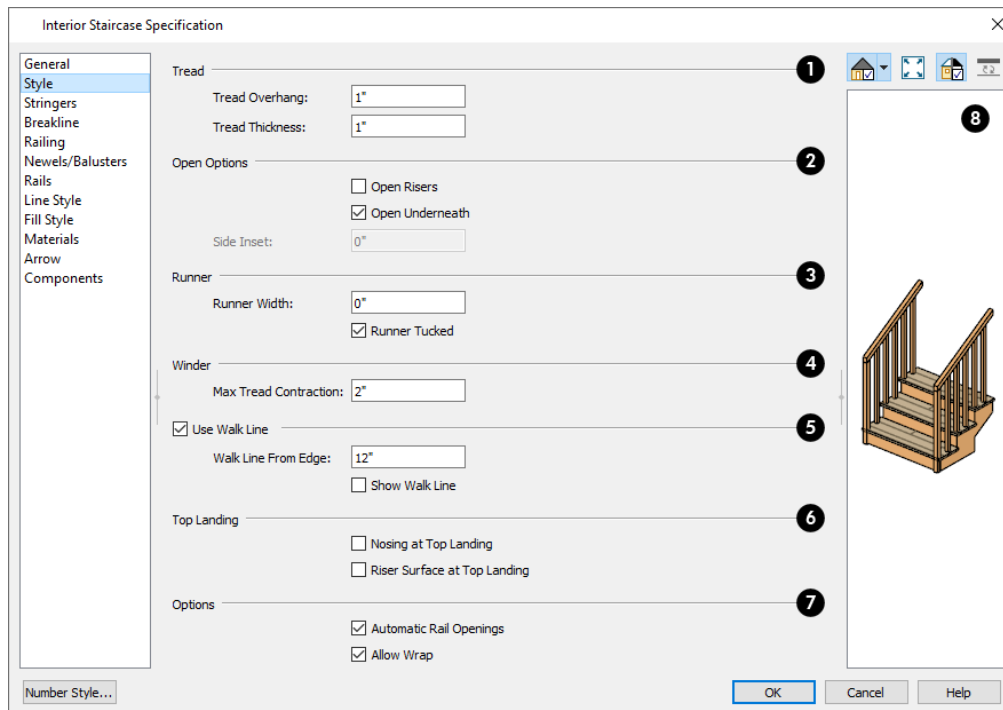

## 1 Tread

See *Anatomy of a Staircase on page 745*.

- Specify the **Tread Overhang**, which is the distance that each tread overhangs the riser.
- Specify the **Tread Thickness**.

## 2 Open Options

The **Open Options** control whether the selected stairs have open risers or an open underside.

- Check **Open Risers** to eliminate the riser face under each tread and expose the stringers.
- Uncheck **Open Underneath** to add a skirt below the staircase along the two sides. It looks like a wall in 3D, but only has a single face. Base molding does not generate along the bottom of the skirt, and doors cannot be placed in it. In most cases, the recommended way to enclose the area beneath stairs is to use walls. See *Rooms Below Staircases on page 770*.
- Specify the **Side Inset** of the skirt below the staircase. The default value of 0 aligns the skirt with the outside of the surface of the stringers. Only available when **Open Underneath** is unchecked.

## 3 Runner

Specify the attributes of the staircase's carpet **Runner**. Only available when **Open Risers** is unchecked, above.

- Specify the **Runner Width**. The default value of 0 does not create a runner.
- Uncheck **Runner Tucked** to have the runner drop straight down from the tread front to the riser below. This is checked by default.

## 4 Winder

Define the **Max Tread Contraction**, which is the amount a tread's width may be reduced when it meets a wall. See *Partial Railings on page 766*.

This option only takes effect when the stairs are specified as **Winders** on the GENERAL panel. See *General Panel on page 771*.

## 5 Use Walk Line

See *Walk Line on page 756*.

- Check **Use Walk Line** to have the program calculate the tread depth based on a Walk Line. Uncheck the box to disable this function.
- Specify the distance of the **Walk Line from Edge**. The default value is 12" (300 mm).
- Check **Show Walk Line** to show the Walk Line in plan view.

## 6 Top Landing

Specify the appearance of the staircase where it meets the next floor platform. These options do not affect the edges of landings.

- Check **Nosing at Top Landing** to produce tread nosing attached to platform edge at the top of stairs.
- Check **Riser Surface at Top Landing** to produce a riser surface against the platform edge at the top of the stairs. This allows stair risers to match all the way to the top of the platform.

## 7 Options

- Check **Automatic Railing Openings** to automatically create a doorway opening when the selected stairs are snapped to a railing drawn on the same floor as the stairs. This is checked by default.
- Check **Allow Wrap** to wrap the selected stairs around the corner of a deck or landing where another, identical stair section is present. See *Wrapped Stairs on page 763*.

## 8 Preview

A preview of the selected staircase displays on the right side of the panel. If the staircase includes any landings, only the section that was selected when the dialog was opened will display. See *Dialog Preview Panes on page 22*.

## STRINGERS PANEL

The settings on the STRINGERS panel affect all sections of a selected staircase.

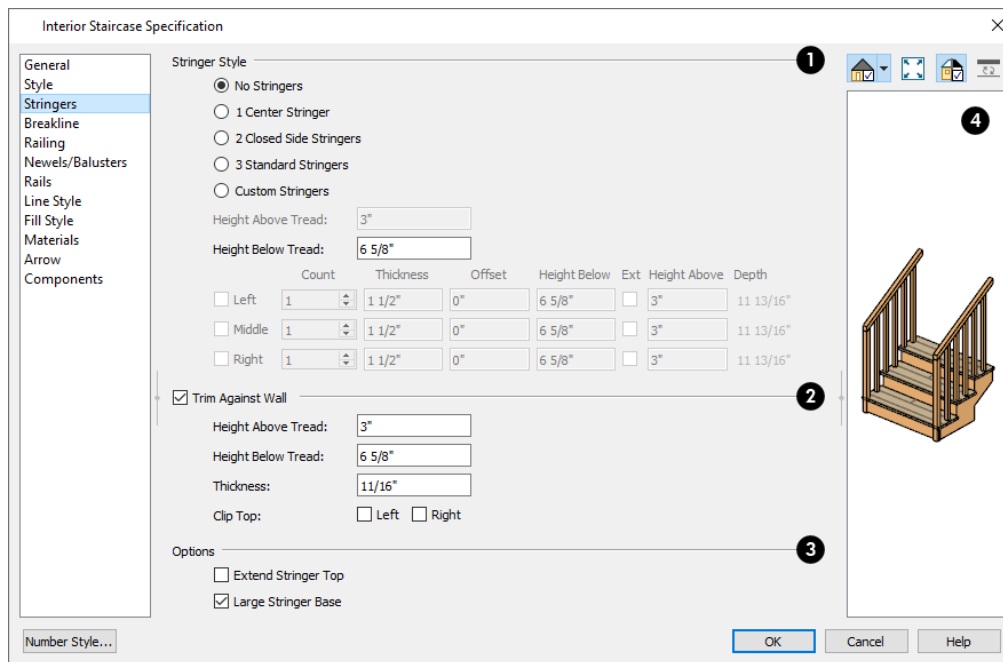

## 1 Stringer Style

- Click a radio button to specify the number of stringers assigned to the staircase. Select **Custom Stringers** to enable the Left, Middle, and Right settings below.
- Specify the **Height Above Tread**, measured straight down from the top outer edge of the tread nosing to the top of the stringer. Only available when 2 Closed Side Stringers is selected, above.
- Specify the **Height Below Tread**, measured straight down from the back bottom edge of the tread to the bottom of the stringer. Not available when Custom Stringers is selected, above.

The **Left**, **Middle**, and **Right** settings are enabled when Custom Stringers is selected. For each of these:

- Specify the **Count** for each stringer location. Multiple Left and Right stringers are butted side to side while multiple Middle stringers are evenly spaced between them.
- Specify the **Thickness**, measured horizontally.



- Specify the **Offset** of each stringer from its default location. A positive value offsets the stringer(s) to the right; a negative value offsets them to the left.
- Specify the **Height Below** the treads, measured straight down from the back bottom edge of the tread to the bottom of the stringer.
- Check **Ext** to specify the stringer(s) as Exterior and allow them to extend up past the top of the stair treads.
- Specify the **Height Above** the stair treads, measured straight down from the top outer edge of the tread nosing to the top of the stringer.
- The vertical **Depth** of the stringers is reported here for reference. This value is affected by the Heights above and below the treads, as well as the stairs Rise Angle.

## 2 Trim Against Wall

Specify the attributes of the **Trim Against Wall** that generates when the staircase is positioned against a wall.

- Specify the **Height Above Tread**, measured straight down from the top outer edge of the tread nosing to the top of the tread.
- Specify the **Height Below Tread**, measured straight down from the back bottom edge of the tread to the bottom of the trim.
- Specify the **Thickness** of the trim, measured horizontally.
- **Clip Top** - Specify whether to clip the top of the trim where it meets the upper floor level. Trim can be clipped on the **Left** and/or **Right** sides of the staircase.

## 3 Options

- **Extend Stringer Top** is checked by default and extends a triangular portion of the stringer under the landing or platform at the top of the stairs.
- Check **Large Stringer Base** to widen the stringers at the foot of the staircase. This is helpful when walls are created below the stairs.

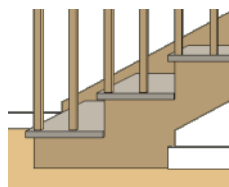

## 4 Preview

A preview of the selected staircase displays on the right side of the panel. To see the stringers, click in the preview and drag upward to rotate. See [Dialog Preview Panes on page 22](#).

## BREAKLINE PANEL

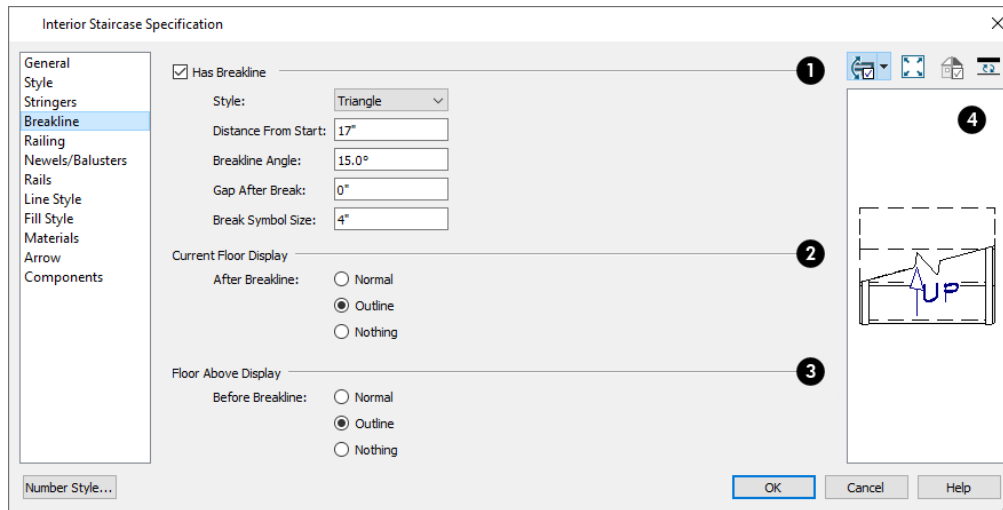

### 1 Has Breakline

Check **Has Breakline** to display a breakline on the selected stairs and enable the settings that follow.

- Select the breakline symbol **Style** from the drop-down list.
- Specify the **Distance from Start**, which is the distance from the front of the stairs to the breakline, measured from the staircase’s center line.
- Specify the **Breakline Angle**. An angle of 0° produces a breakline that is perpendicular to the sides of a straight stairwell.
- Specify the **Gap After Break**, which is the gap between the section of the stairs located below the breakline and that located above it. A value of 0 produces no gap.
- Specify the **Break Symbol Size**, which is the total height of the break symbol measured from top corner to bottom corner.

### 2 Current Floor Display

The **Current Floor Display** settings control the appearance of the portion of the staircase located **After** the **Breakline**, or upslope from it, on the floor where the stairs were drawn.

- Select **Normal** to display the staircase after the breakline using the same Line and Fill Styles as the portion located before the breakline.
- Select **Outline** to display the staircase after the breakline using the Line Style assigned to the “Stairs & Ramps, Details” layer and a transparent fill.
- Select **Nothing** to hide the display of the staircase after the breakline entirely.

### 3 Floor Above Display

The **Floor Above Display** settings control the appearance of the portion of the staircase located **Before** the **Breakline**, as seen from the floor above the stairs.

- Select **Normal** to display the staircase before the breakline using the same Line and Fill Styles as the portion located after the breakline.
- Select **Outline** to display the staircase before the breakline using the Line Style assigned to the “Stairs & Ramps, Details” layer and a transparent fill.
- Select **Nothing** to hide the display of the staircase before the breakline entirely.

Note: Stairs located on the floor below can only be seen if a Stairwell room is defined above them. See *Creating a Stairwell on page 769*.

#### 4 Preview

A preview of the selected staircase displays on the right side of the panel. If the staircase includes any landings, only the section that was selected when the dialog was opened will display. See *Dialog Preview Panes on page 22*.

### RAILING PANEL

By default, the settings on the RAILING panel also affect the railings on any landings attached to the selected staircase or ramp. See *Landings on page 755*.

This panel is also found in the Ramp and Landing Specification dialogs.

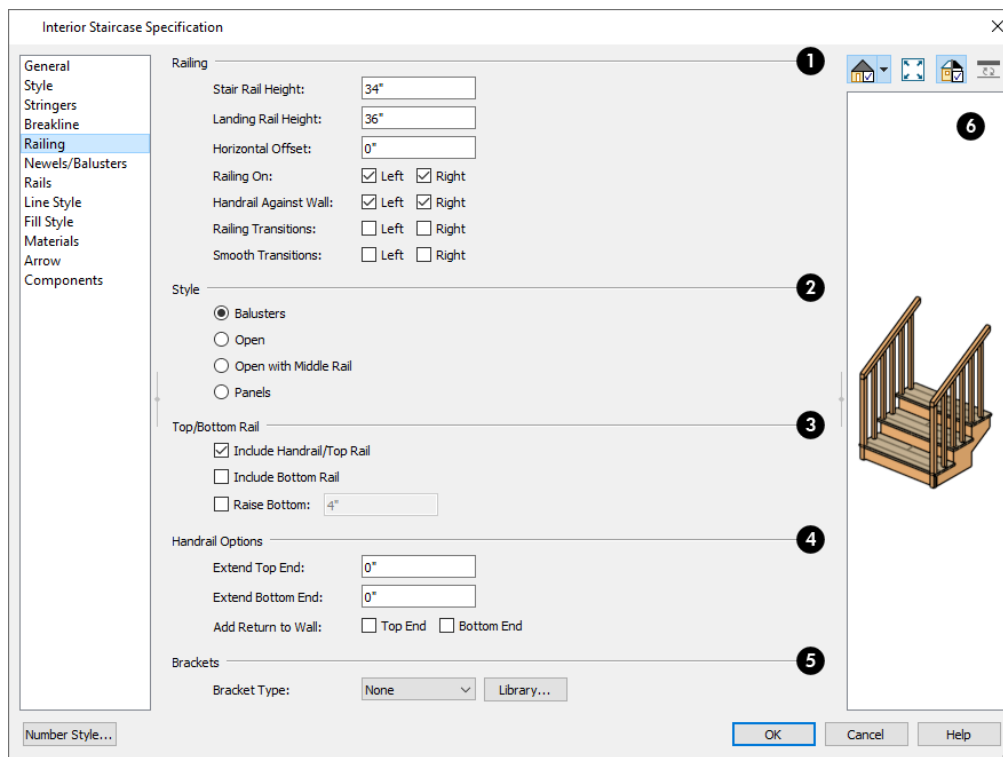

#### 1 Railing

- **Stair Rail Height** defines the height from tread surface directly over the riser to railing top.
- **Landing Rail Height** defines the height of the landing rail top from the landing surface.

- **Horizontal Offset** allows you to place the railings either inside or outside their default location aligned with the edge of the stairs. A positive value offsets the railings inward while a negative value offsets them outward.
- **Railing On** - Select **Left** and/or **Right** to specify placement of railings on stair sections.
- **Railing at Wall** - Select **Left** and/or **Right** to specify the placement of wall railings. Not available for ramps.

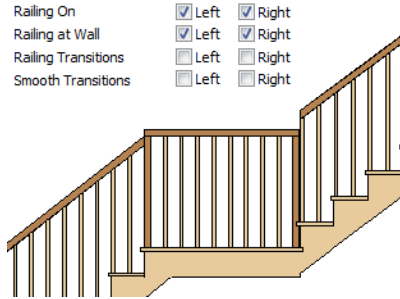

- Check **Railing Transitions** on **Left** and/or **Right** to create “gooseneck” connections between stair and landing railings. This option only has an effect when **Rail Passes Over Newel** is checked. Not available for ramps.

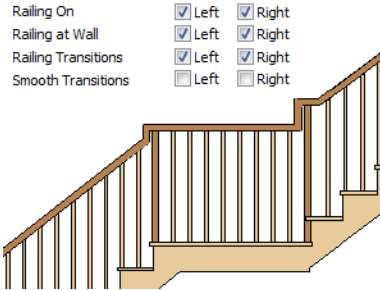

- Check **Smooth Transitions** on **Left** and/or **Right** to specify the placement of smooth connections between stair and landing railings. Not available for ramps.

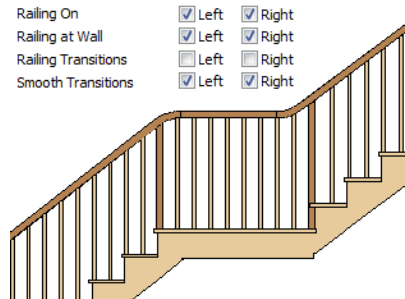

- Check both **Railing Transitions** and **Smooth Transitions** to produce a handrail like this:

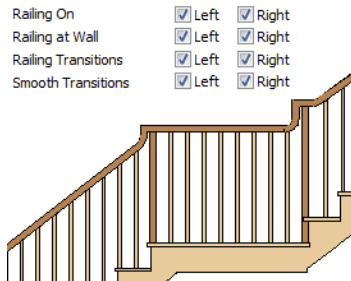

## 2 Style

- Select **Balusters** to create regularly spaced balusters between larger newel posts.
- Select **Open** to create with only newels posts.
- Select **Open with Middle Rail** to create railings with newel posts and a middle rail.
- Select **Panels** to create railings composed of panels. The panel style is specified on the NEWELS/BALUSTERS panel. See *Newels/Balusters Panel on page 781*.

## 3 Top/Bottom Rail

- Check **Include Handrail/Top Rail** to produce a top rail on the stair railings that receives the top baluster ends and typically acts as a handrail.
- Check **Include Bottom Rail** to place a low rail on the landing surface that receives the balusters ends.

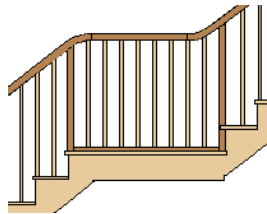

- Check **Raise Bottom**, then specify the distance to raise the bottom rail or panel from the stair tread.

## 4 Handrail Options

- Specify the **Extend Top End** value, which is the distance that the top of each railing section extends past the top riser of its corresponding stair section.
- Specify the **Extend Bottom End** value, which is the distance that the bottom of each railing section extends past the bottom riser of its corresponding stair section.
- Specify where to **Add Return to Wall**:
  - Check **Top End** to add a return to the wall at the top end of all railing sections that are against a wall.
  - Check **Bottom End** to add a return to the wall at the bottom end of all railing sections that are against a wall.

## 5 Brackets

Click the **Library** button to apply a 1/4" (2 mm) thick decorative bracket to the exposed sides of the stringers, under each riser. A side stringer with brackets will be moved in 1/4" (2 mm) to accommodate the bracket. See *Select Library Object Dialog on page 974*.

## 6 Preview

A preview of the selected staircase displays on the right side of the panel. If the staircase includes any landings, only the section that was selected when the dialog was opened will display. See *Dialog Preview Panes on page 22*.

## NEWELS/BALUSTERS PANEL

The settings on the NEWELS/BALUSTERS panel will also affect the appearance of railings on any landings attached to the selected staircase. See *Landings on page 755*.

These settings are similar to those found on the same panel of the Ramp and Landing Specification dialogs. See [Ramp Specification Dialog on page 784](#).

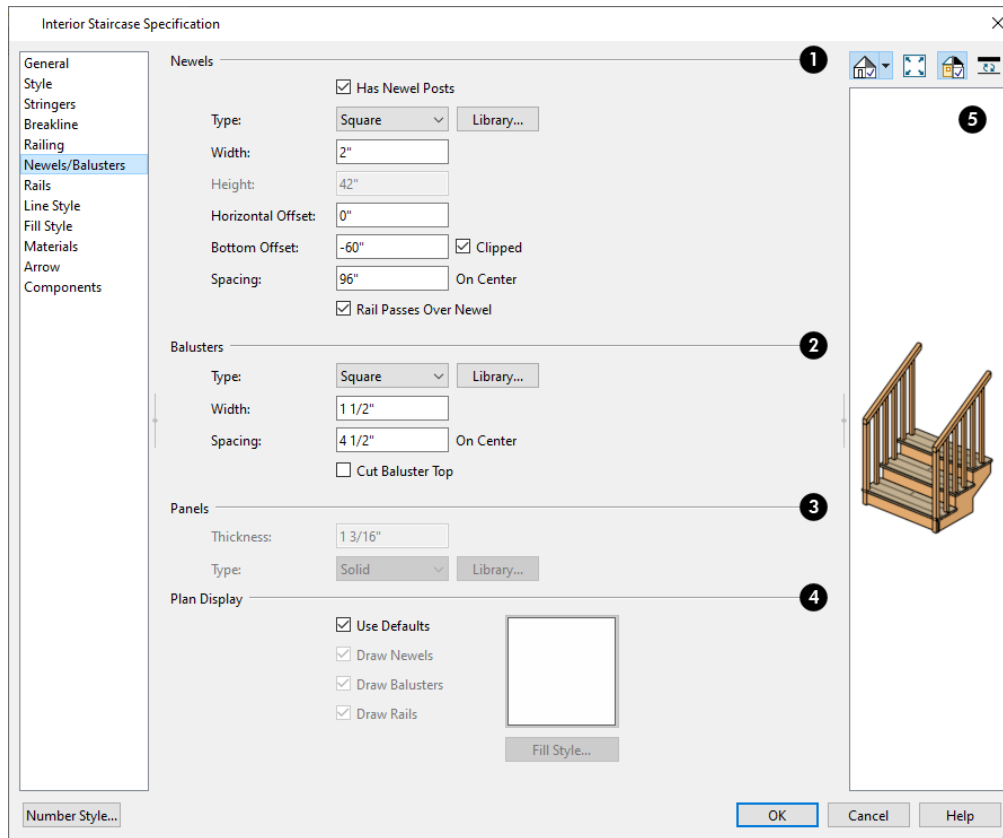

## 1 Newels

- Uncheck **Has Newel Posts** to prevent newels from generating in the selected staircase's railings. When this box is checked, newels are generated and can be edited using the settings that follow.
- **Type** - Select **Square**, **Round**, or newels from the **Library**. Selecting **Library** from the drop-down list is the same as clicking the **Library** button to the right and allows selection of a newel from the library.
- Specify the **Width**, which is the width or diameter of each newel. For Library newels, this is the width at its widest point.
- Specify the **Height**, which is the height from the landing surface to the top of the newel. Only available when **Rail Passes Over Newel** is unchecked below.
- Specify the **Horizontal Offset**, which is the amount each newel is offset from the center of the railing.
- Specify the **Bottom Offset**, which is the amount each newel's bottom is offset from the tread or floor surface beneath it.
- Check **Clipped** to clip any newels that extend down to or past the floor level at the floor surface.
- Specify the on-center **Spacing** of the newel posts.

## 2 Balusters

The first three **Balusters** settings are similar to the Newels options of the same names, above.

- **Cut Baluster Top** - Each tread normally has two to three balusters, growing longer toward its back. The default is to use the same baluster and cut it off at the bottom to shorten it toward the tread front. Check this box to cut the balusters at the top instead.

### 3 Panels

These settings are only available when the railing Style specified as “Panels” on the *Railing Panel on page 779*.

- Specify the panel’s **Thickness**.
- Select “Solid” or “Library” from the **Type** drop-down list.



You can also apply newels, balusters, and panels onto stair or ramp railing directly from the Library Browser. See *Inserted Objects on page 973*.

### 4 Plan Display

These settings the display of newels, balusters, and rails in plan view. See *In Plan View on page 749*.

- Uncheck **Use Defaults** to enable the settings that follow. When this is checked, the options set in the Staircase Defaults dialog are used.
- Check **Draw Newels** to display newel posts in plan view. Note that newels at the top of the staircase are associated with the railings defining the stairwell. See *Creating a Stairwell on page 769*.
- Check **Draw Balusters** to display balusters in plan view.
- Check **Draw Rails** to display the handrails in plan view.
- Click the **Fill Style** button to open the Fill Style dialog and specify the fill style for newels, balusters, and/or rails, when set to display.

To display newels/balusters under the handrails, specify a Fill Style of “None”.

### 5 Preview

A preview of the selected staircase displays on the right side of the panel. If the staircase includes any landings, only the section that was selected when the dialog was opened will display. See *Dialog Preview Panes on page 22*.

## RAILS PANEL

The settings on the RAILS panel are similar to those on the RAILS panel of the Wall Specification dialog as well as the MOLDINGS panel of a variety of other dialogs. See *Moldings // Profiles / Rails / Panels on page 927*.

By default, the settings on the RAILS panel will also affect the appearance of railings on any landings attached to the selected staircase. See *Landings on page 755*.

## LINE STYLE PANEL

The settings on the LINE STYLE panel are available for a variety of other objects in the program. For information about these settings, see *Line Style Panel on page 305*.

## FILL STYLE PANEL

The settings on the FILL STYLE panel affect the appearance of the selected staircase in plan view. For information about these settings, see *Fill Style Panel and Dialogs on page 193*.

## MATERIALS PANEL

The settings on the MATERIALS panel affect the appearance of the selected staircase in 3D views and are available for a variety of objects throughout the program. For information about these settings, see [Materials Panel on page 1055](#).

The settings on this panel will also affect the materials applied to any landings attached to the selected staircase. See [Landings on page 755](#).

## ARROW PANEL

The settings on the ARROW panel control the appearance of the selected staircase's direction arrow in plan view. See [In Plan View on page 749](#).



For information about these settings, see [Arrowheads on page 327](#).

## COMPONENTS PANEL

The information on the COMPONENTS panel can be used in the materials list. See [Components Panel on page 1330](#).

---

# Ramp Specification Dialog

 Ramps can be defined with the greatest accuracy using the Ramp Specification dialog. To open this dialog, select one or more ramps and click the **Open Object** edit button or double-click a ramp section using the **Ramp**  or **Select Objects**  tool.

The Ramp Specification dialog has the following panels:



## GENERAL PANEL

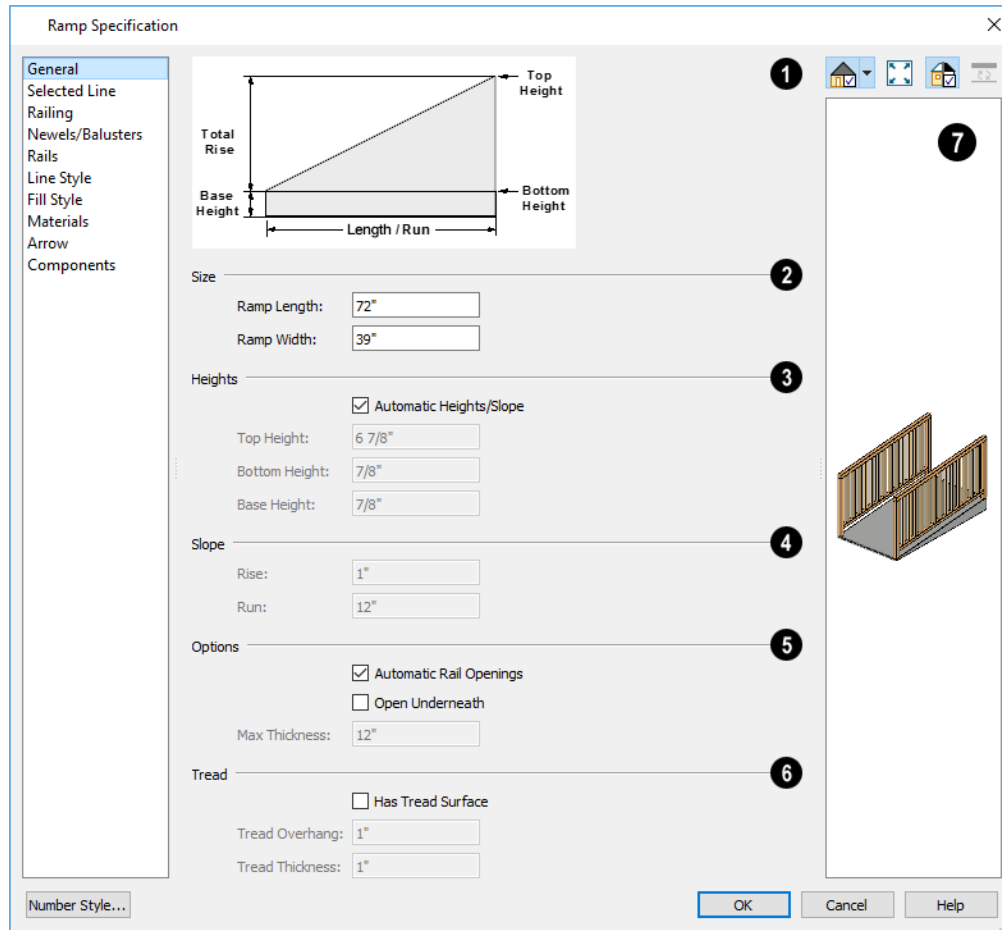

### 1 Diagram

A diagram of a sample ramp’s structure displays here for reference.

### 2 Size

Specify the **Ramp Length** and **Width**.

### 3 Heights

Specify the **Heights** of various key locations on the selected ramp.

- Uncheck **Automatic Heights/Slope** to activate the settings below, then specify the height and slope of the ramp.
- Specify the **Top Height**, which is the height of the ramp at its high end.
- Specify the **Bottom Height**, which is the height of the ramp at its low end.
- Specify the **Base Height**, which is the height of the bottom surface of the ramp.

#### 4 Slope

Specify the ramp's **Slope** by typing its **Rise** value in the first field, and the **Run** value in the second field. See *Anatomy of a Staircase on page 745*.

#### 5 Options

- Check **Automatic Railing Openings** to automatically create a doorway opening when the selected ramp is snapped to a railing drawn on the same floor as the ramp. This is checked by default.
- Check **Open Underneath** to remove the skirt around the bottom of the ramp so that it has a uniform, sloped thickness that may not reach the floor or terrain at the high end. This is unchecked by default.
- Specify the **Max Thickness**, which is the ramp's maximum thickness. At the low end of the ramp where it meets the floor or terrain, its thickness may be less than this value.

#### 6 Tread

Specify the structure of the ramp's **Tread**, which is an optional surface layer placed over the top of the ramp.

- Check **Has Tread Surface** to apply a top tread surface to the ramp and enable the settings below.
- Specify the **Tread Overhang**, which is the distance the tread surface extends past the ramp's edges.
- Specify the **Tread Thickness**, which is the tread surface's vertical depth.

#### 7 Preview

A preview of the selected ramp displays on the right side of the panel. If the ramp is composed of multiple sections separated by landings, only the section that was selected when the dialog was opened will display. See *Dialog Preview Panes on page 22*.

### SELECTED LINE/ARC PANEL

The SELECTED LINE panel is available when the selected ramp segment is a line as opposed to an arc. For more information, see *Line Panel on page 304*.

The SELECTED ARC panel is available when the selected ramp segment has been converted to an arc. For more information, see *Arc Panel on page 312*.

See, too, *Selected Edge on page 212* and *Change Line/Arc on page 256*.

### RAILING PANEL

The settings on the RAILING panel are similar to those on the same panel in the Staircase Specification dialog. For information about these settings, see *Railing Panel on page 779*.

By default, the settings on this panel will also affect the appearance of railings on any landings attached to the selected ramp. See *Landings on page 755*.

### NEWELS/BALUSTERS PANEL

The settings on the NEWELS/BALUSTERS panel are similar to those on the same panel in the Staircase Specification dialog. For more information, see *Newels/Balusters Panel on page 781*.

By default, the settings on this panel will also affect the appearance of railings on any landings attached to the selected ramp. See *Landings on page 755*.

## RAILS PANEL

The settings on the RAILS panel are similar to those on the RAILS panel of the Staircase Specification dialog as well as the MOLDINGS panel of a variety of other dialogs. See *Moldings // Profiles / Rails / Panels on page 927*.

By default, the settings on this panel will also affect the appearance of railings on any landings attached to the selected ramp. See *Landings on page 755*.

## LINE STYLE PANEL

The settings on the LINE STYLE panel are available for a variety of other objects in the program. For information about these settings, see *Line Style Panel on page 305*.

## FILL STYLE PANEL

The settings on the FILL STYLE panel affect the appearance of the selected ramp in plan view. For information about these settings, see *Fill Style Panel and Dialogs on page 193*.

## MATERIALS PANEL

The settings on the MATERIALS panel affect the appearance of the selected ramp in 3D views and are available for a variety of objects throughout the program. For information about these settings, see *Materials Panel on page 1055*.

The settings on this panel will also affect the materials applied to any landings attached to the selected ramp. See *Landings on page 755*.

## ARROW PANEL

The settings on the ARROW panel control the appearance of the selected ramp's direction arrow in plan view. See *In Plan View on page 749*.

For information about these settings, see *Arrowheads on page 327*.

## COMPONENTS PANEL

The information on the COMPONENTS panel can be used in the materials list. For more information, see *Components Panel on page 1330*.

---

# Stair Landing Specification Dialog



Select a landing and click the **Open Object** edit button to open the Stair Landing Specification dialog. See *Landings on page 755*.

The Stair Landing Specification dialog has the following panels:

## GENERAL PANEL

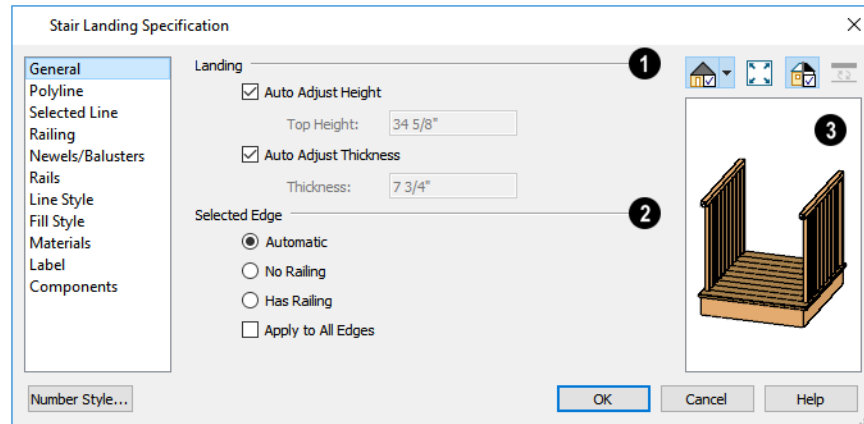

### 1 Landing

Uncheck **Auto Adjust Height** to specify the selected landing's **Top Height**.

- A free-standing interior landing will have a default Top Height equal to one riser plus the thickness of the default floor finish. A free-standing exterior landing will have a default top height equal to its thickness. When this box is checked, the landing height may adjust as needed to maintain consistent riser height in all connected stair sections, ramp sections, or adjacent landings.
- The **Top Height** field is only active when Auto Adjust Height is unchecked. See [Landing Height and Thickness on page 756](#).

Note: A network of adjacent landings can only be created when Auto Adjust Height is checked. See [Adjacent Landings on page 755](#).

Uncheck **Auto Adjust Thickness** to specify the selected landing's **Thickness**.

- A free-standing landing will have a default thickness of 6 3/4" (169 mm). When checked, the thickness is based on the riser height of the stair sections it is attached to, or the thickness of the ramps it is attached to.
- The **Thickness** field is only active when Auto Adjust Thickness is unchecked.

### 2 Selected Edge

Specify how railings are applied to the landing's **Selected Edge**. See [Selected Edge on page 212](#).

- Select **Automatic** to suppress the railing on any portion of the selected edge that either connects to a stair or ramp section or has an adjacent landing, but to produce a railing where that is not the case. See [Landing Railings on page 756](#).
- Select **No Railing** to suppress the railing on the selected edge of this landing.
- Select **Has Railing** to produce a railing along the selected edge, even where it connects to a stair or ramp section or has an adjacent landing.
- Check **Apply to All Edges** to apply your selection to all edges of the landing. This is an action rather than a state - the next time this dialog is opened, this box will be unchecked.

### 3 Preview

A preview of the selected landing displays on the right side of the panel. See [Dialog Preview Panes on page 22](#).

## POLYLINE PANEL

The POLYLINE panel states the length of the landing's **Perimeter**, its enclosed **Area**, and its **Volume**.

The settings on this panel are available for a variety of other objects in the program. See [Polyline Panel on page 317](#).

## SELECTED LINE/ARC PANEL

The SELECTED LINE panel is available when the selected edge is a line as opposed to an arc. For more information, see [Line Panel on page 304](#).

The SELECTED ARC panel is available when the selected edge has been converted to an arc. For more information, see [Arc Panel on page 312](#).

See, too, [Selected Edge on page 212](#) and [Change Line/Arc on page 256](#).

## RAILING PANEL

The settings on the RAILING panel are similar to those on the same panel in the Staircase Specification dialog. For information about these settings, see [Railing Panel on page 779](#).

There is one setting that is unique to the Landing Specification dialog:

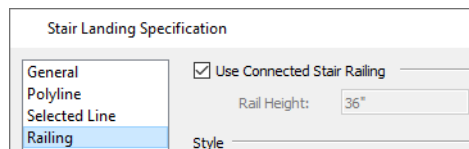

Uncheck **Use Connected Stair** or **Ramp Railing** to enable the settings on this panel, the NEWELS/BALUSTERS panel, and the RAILS panel. When checked, the selected landing derives all railing settings from the connected stairs or ramp.

If the selected landing is not connected to a stair or ramp, this check box will be named **Use Default Interior** or **Exterior Stair Railing**, depending on where the landing is located.

## NEWELS/BALUSTERS PANEL

The settings on the NEWELS/BALUSTERS panel are similar to those on the same panel in the Staircase Specification dialog. For more information, see [Newels/Balusters Panel on page 781](#).

By default, the settings on this panel will also affect the appearance of railings on any landings attached to the selected ramp. See [Landings on page 755](#).

## RAILS PANEL

The settings on the RAILS panel are similar to those on the RAILS panel of the Staircase Specification dialog as well as the MOLDINGS panel of a variety of other dialogs. See [Moldings // Profiles / Rails / Panels on page 927](#).

## LINE STYLE PANEL

The settings on the LINE STYLE panel are available for a variety of objects throughout the program. See [Line Style Panel on page 305](#).

## **FILL STYLE PANEL**

The settings on the FILL STYLE panel affect the appearance of the selected landing in plan view. See *Fill Style Panel and Dialogs on page 193*.

## **MATERIALS PANEL**

When a landing is attached to stairs or a ramp, its initial materials are derived from the stairs or ramp. When the landing is attached to a ramp, its top surface material is defined by the Landing Sides component unless the ramp is using a Tread material.

The settings on this are available for a variety of objects throughout the program. For information about these settings, see *Materials Panel on page 1055*.

## **LABEL PANEL**

Labels for stair landings display in plan view and cross section/elevation views when the “Polylines 3D, Labels” layer is turned on and use the Text Style assigned to that layer. See *Displaying Stairs, Ramps, and Landings on page 749*.

For information about the settings on this panel, see *Label Panel on page 700*.

## **COMPONENTS PANEL**

The information on the COMPONENTS panel can be used in the materials list. For more information, see *Components Panel on page 1330*.

# Roofs

## Chapter 23

Chief Architect’s manual and automatic Roof Tools allow you to draw almost any roof style.



Verify that all roof planes join as intended. The program does not confirm correct geometry between manually designed or edited roof planes. It is possible to design and edit roof planes with hips and valleys that do not meet properly.

### TOPICS

<b>Automatic vs. Manual Roofs</b> .....	<b>792</b>
<b>Roof Defaults</b> .....	<b>792</b>
<b>The Roof Tools</b> .....	<b>793</b>
<b>Automatic Roofs</b> .....	<b>795</b>
<b>Build Roof Dialog</b> .....	<b>797</b>
<b>Roof Planes</b> .....	<b>804</b>
<b>Displaying Roofs</b> .....	<b>806</b>
<b>Editing Roof and Ceiling Planes</b> .....	<b>808</b>
<b>Connecting Roof and Ceiling Planes</b> .....	<b>811</b>
<b>Roof Plane Specification Dialog</b> .....	<b>814</b>
<b>Roof Baseline Polylines</b> .....	<b>819</b>
<b>Roof Baseline Specification Dialog</b> .....	<b>821</b>
<b>Roof and Ceiling Framing</b> .....	<b>822</b>
<b>Curved Roof Planes</b> .....	<b>823</b>
<b>Ceiling Planes</b> .....	<b>826</b>
<b>Ceiling Plane Specification Dialog</b> .....	<b>828</b>
<b>Gable/Roof Lines</b> .....	<b>830</b>
<b>Gable Line Specification Dialog</b> .....	<b>833</b>
<b>Skylights and Roof Holes</b> .....	<b>834</b>
<b>Skylight/Roof Hole Specification Dialog</b> .....	<b>835</b>
<b>Dormers and Crickets</b> .....	<b>838</b>
<b>Editing Auto Dormers</b> .....	<b>840</b>
<b>Dormer Specification Dialog</b> .....	<b>841</b>
<b>Roof Returns and Other Details</b> .....	<b>844</b>
<b>Roof Pitches in Degrees</b> .....	<b>849</b>

---

## Automatic vs. Manual Roofs

Chief Architect can create just about any roof style. Most common roof styles such as hips and gables can easily be generated automatically.

More complex roof styles, including curved roof planes, can be created manually. The manual roof tools allow you to create any roof system that can be represented using roof planes.

### AUTOMATICALLY GENERATED ROOFS

The quickest and easiest way to create a roof over a structure is automatically. By default, a roof plane is generated over each exterior wall, creating a hip roof. The program automatically joins the roof planes at ridges, hips, and valleys and tries to create roof planes that join together to form a single, integrated system. See [Automatic Roofs on page 795](#).

Any deviations from the default hip roof can be specified on the ROOF panel of the Wall Specification dialog for any exterior wall. Here, you can specify a Full Gable Wall, High/Shed Gable Wall, or other options instead of a default hip roof. You can also specify a different overhang, pitch, an upper pitch, and the elevation where the upper pitch begins for the roof plane that rests on the selected wall. See [Roof Directives in Walls on page 378](#).

When you need the roof planes over an area of a plan to be entirely separate from those over the rest of the structure, you can assign those areas to a non-default Roof Group. See [Roof Groups on page 795](#).

Roofs can also be automatically generated based on a Roof Baseline Polyline. When a Roof Baseline Polyline is used, information that determines where and how roof planes are generated is contained in the Roof Baseline Specification dialog. See [Roof Baseline Polylines on page 819](#).

Bay, bow, and box windows also produce roof planes automatically. For information about these windows and the roof styles that can be used with them, see [Bay, Box, Bow Windows and Roofs on page 610](#).

### MANUALLY DRAWN ROOFS

Any roof system that can be created automatically can also be created manually. Each roof plane is drawn and edited individually, offering full control over the process and limiting the possibilities only to your imagination.

Note: You cannot manually draw or edit roof planes when Auto Rebuild Roofs is enabled in the Build Roof dialog. See <a href="#">Roof Panel on page 798</a> .
--

### USING BOTH TECHNIQUES

Another useful option is to start with an automatically generated roof and use manual design techniques to finish it. Using both automatic roof generation and the manual roof drawing and editing techniques, you can quickly design highly customized roof systems.

---

## Roof Defaults



Select **Edit> Default Settings**, to open the Default Settings dialog for a variety of drawing tools, several of which directly affect roof generation.



## ROOF DEFAULTS DIALOG

The Build Roof and Roof Defaults dialogs are nearly identical in appearance and function. The only difference is that the Build Roof dialog has a number of check boxes that allow you to automatically generate roof planes and related objects. See [Build Roof Dialog on page 797](#).

If changes are made to the settings in this dialog after the roof has been built, you will need to rebuild the roof in order for your changes to take effect.

## ROOF FRAMING DEFAULTS

Default settings for framing can be specified in either the Build Roof, Framing Defaults, or the Framing Defaults dialog. Framing defaults control the depth of roof planes as well as the depth of floor and ceiling platforms, which influence roof plane heights. See [Framing Defaults on page 851](#).

To create roof planes with a particular assembly of layers, begin by setting up the desired roof framing defaults, then build the roof. If you later need to change the structure of the roof planes, make the needed change to the Framing Defaults, and then rebuild the roof. You can also edit the structure of individual roof planes.

## FLOOR AND CEILING HEIGHTS

The initial heights of floors and ceilings, which influence roof heights, are specified in the Floor Defaults dialog for each floor. See [Floor Defaults Dialog on page 731](#).

The floor and ceiling heights in individual rooms also influence roof heights and are specified in the Room Specification dialog. See [Structure Panel on page 439](#).

 If Auto Rebuild Roofs is checked in the Build Roof dialog and you change floor or ceiling heights, floor or ceiling platform depths, wall positions or roof directives in walls, the roof rebuilds to reflect your changes. See [Rebuilding Roofs on page 796](#).

## WALL SPECIFICATION DIALOG

By default, when an automatic roof is built, a roof plane is generated over each exterior wall, creating a hip roof.

Any deviations from this default hip roof, such as a gable or a different pitch, can be specified in the Wall Specification dialog for any exterior wall. See [Roof Panel on page 398](#).

## DORMER DEFAULTS

The settings in the Dormer Defaults dialog determine the initial settings for automatic dormers and are much like those in the Dormer Specification dialog. See [Dormer Specification Dialog on page 841](#).

The Dormer Defaults dialog can be opened from the Default Settings dialog or by double-clicking either of the **Auto Dormer**  tools.

---

# The Roof Tools

 Select **Build> Roof** to access the Roof Tools.

## BUILD ROOF



Select **Build> Roof> Build Roof** to open the Build Roof dialog, specify the settings for automatically generated and manually drawn roof planes as well as manually drawn ceiling planes, and build or rebuild a roof. See *Build Roof Dialog on page 797*.

When roofs are automatically generated, a roof plane is created over each exterior wall by default, resulting in a hip roof, and the program tries to join them together to form a single, integrated system.

To automatically generate a roof plane using values other than the defaults or to not generate a roof plane bearing on a particular wall (as with a gable or the sides of a shed roof), you can change the settings in the Wall Specification dialog. See *Roof Panel on page 398*.

## ROOF PLANE



Select **Build> Roof> Roof Plane** to draw a roof plane manually. See *Roof Planes on page 804*. You can also double-click the **Roof Plane** button to open the Build Roof dialog.

Note: You cannot use the Roof Plane tool when Auto Rebuild Roofs is enabled in the Build Roof dialog. See *Manually Drawn Roofs on page 792*.

## CEILING PLANE



Select **Build> Roof> Ceiling Plane** to draw a ceiling plane manually. Ceiling planes are drawn and behave much like roof planes. See *Ceiling Planes on page 826*.

## TRAY CEILING POLYLINE



Select **Build> Roof> Tray Ceiling Polyline**, then click and drag to draw a closed polyline within a room. See *Tray and Coffered Ceilings on page 430*.

## GABLE/ROOF LINE



Select **Build> Roof> Gable/Roof Line** to draw a gable line that generates a gable along a baseline edge when roofs are automatically generated. See *Gable/Roof Lines on page 830*.

## SKYLIGHT



Select **Build> Roof> Skylight**, then draw a rectangle over an existing roof plane to create a skylight. The skylight, skylight shaft, and ceiling hole (if a ceiling exists) are drawn at the same time. See *Skylights and Roof Holes on page 834*.

## AUTO FLOATING DORMER



Select **Build> Roof> Auto Floating Dormer** and click within an existing roof plane to place an auto floating dormer. See *Dormers and Crickets on page 838*.

## AUTO DORMER



Select **Build> Roof> Auto Dormer** and click within a roof plane to place a dormer. See *Dormers and Crickets on page 838*.

## EDIT ALL ROOF PLANES



Select **Build> Roof> Edit All Roof Planes** to open the Roof Plane Specification dialog and edit all roof planes in the entire plan at once. See *Roof Plane Specification Dialog on page 814*.

## DELETE ROOF PLANES



Select **Build> Roof> Delete Roof Planes** to delete all roof planes in the plan. See *Deleting Roof Planes on page 811*.

## DELETE CEILING PLANES



Select **Build> Roof> Delete Ceiling Planes** to delete all manually drawn ceiling planes in the plan. See *Ceiling Planes on page 826*.

## FIX ROOFS



Select **Build> Roof> Fix Roofs** to remove breaks where a single edge of one roof plane meets the broken edge of another along a ridge, hip or valley. **Fix Roofs** does not affect eave edges. See *Roof Edges and Walls on page 810*.

---

# Automatic Roofs

When roofs are automatically generated, a roof plane is created over each exterior wall by default, resulting in a hip roof, and the program tries to join them together to form a single, integrated system.

There are a number of options available to produce variations in this default roof style.

## ROOF DIRECTIVES IN WALLS

To automatically generate a roof plane using values other than the defaults or to not generate a roof plane bearing on a particular wall (as with a gable or the sides of a shed roof), you can change the settings in the Wall Specification dialog for that wall. See *Roof Panel on page 398*.

## ROOF GROUPS

When an automatic roof is generated, the program tries to create roof planes that join together to form a single, integrated system. Different parts of the structure influence how the roof is generated over the whole.

When you need the roof planes over an area of a plan to be entirely separate from those over the rest of the structure, you can assign those areas to a non-default Roof Group. The program treats different Roof Groups as separate buildings for the purpose of automatic roof generation, preventing their roofs from influencing one another.

Bear in mind that the use of Roof Groups typically involves using a combination of both automatic roof generation and manual roof editing, and that changes to Attic walls may also be necessary. See *Using Both Techniques on page 792*.

Roof Groups are assigned using numbers. The Default Roof Group is always 0, and you can assign rooms to other roof groups in the Room Specification dialog. See *General Panel on page 438*.

## CURVED WALLS AND ROOFS

Automatically generated roof planes are placed over curved walls at specified increments. In the Build Roof dialog, you can specify the degree increments for the roof over curved walls, from 6° to 90°. The lower the number, the more roof sections are created over the curved wall.

The following illustrations show a roof created at two different curved increments: 30° and 15°.

Segment Angle at Curved Wall	15.0°
Minimum Alcove Size	36°

## CONCAVE CURVED WALLS AND ROOFS

Regular roof plane sections can also generate over concave curved walls. For roof sections to generate over a concave curved wall, the sections' baselines must be longer than the **Minimum Alcove Size** value on the BUILD panel of the Build Roof dialog.

If the baselines are shorter, the automatically generated roofs are simplified by either:

- Ignoring the curved wall, as if the walls on either side extended to their meeting point.

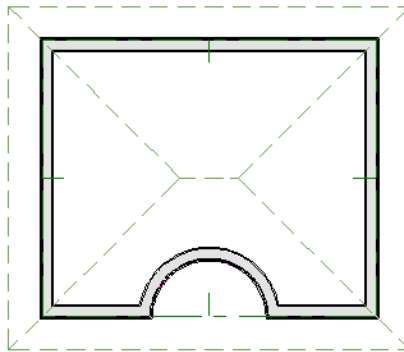

- Spanning the concave curved wall with a straight Baseline and produce a roof plane for it from that.

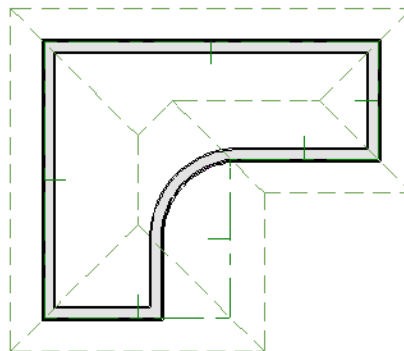

## REBUILDING ROOFS

When **Auto Rebuild Roofs** is unchecked in the Build Roofs dialog and changes are made to the model, the roof will not update to reflect these changes. This is the case even if the roof was automatically built. On the other hand, when **Auto Rebuild Roofs** is checked, any changes made to the position of an exterior wall or to its roof directives will prompt the roof to regenerate to reflect these changes. See [Roof Panel on page 798](#).

Changes made to floor heights, ceiling heights, or floor or ceiling platform thicknesses will also cause the roof to be automatically rebuilt. See [Editing Rooms on page 419](#).

You can also rebuild the roof at any time to reflect the current state of the model by opening the Build Roof dialog, checking **Build Roof Planes**, and clicking OK.

Manually drawn roof planes are specified as such in the Roof Plane Specification dialog. If a roof plane was automatically generated, it will instead have a **Mark as Edited** check box. See [Roof Plane Specification Dialog on page 814](#).

When the roof is rebuilt using **Auto Rebuild Roof** or **Build Roof Planes** in the Build Roof dialog, all roof planes in the plan, both automatically generated and manually drawn, are deleted and replaced.

- To preserve any manually drawn roof planes, check **Retain Manually Drawn Roof Planes** on the BUILD panel of the Build Roof dialog before the roof is rebuilt.
- To preserve any automatically generated roof planes that you have edited, check **Retain Edited Roof Planes** on the BUILD panel of the Build Roof dialog before the roof is rebuilt.

Note: Under some conditions, when the roof is rebuilt new roof planes may be generated in the same location as retained manually drawn or automatic roof planes.



Roof planes cannot be edited or manually drawn when **Auto Rebuild Roofs** is turned on. If you try to either edit or draw a roof plane using the **Roof Plane**  tool, a question message will display.

---

## Build Roof Dialog



The Build Roof dialog is used to automatically build or rebuild roof planes and generate Roof Baseline Polyines. The settings in this dialog act as defaults for both manually drawn and automatic roofs. See [Roof Defaults on page 792](#).

To open the Build Roof dialog, select **Build> Roof> Build Roof** . You can also double-click the **Roof Tools**  button or the **Roof Plane**  button to open this dialog.

Roof planes and Roof Baseline Polyines are generated based on the positions and roof directive settings for each exterior wall in the plan. If you make changes to any of these walls or to any of the settings in this dialog, you will need to build the roof again for them to take effect. See [Roof Panel on page 398](#).

Aside from a number of check boxes on the ROOF panel that allow you to automatically generate roof planes and related objects, the settings in this dialog are also found in the Roof Defaults dialog. See [Roof Defaults on page 792](#).

The settings in this dialog are similar to those found in the Roof Plane Specification dialog, but affect all subsequently created roof planes rather than one or more selected roof planes. See [Roof Plane Specification Dialog on page 814](#).

The Build Roof dialog has the following panels:

## ROOF PANEL

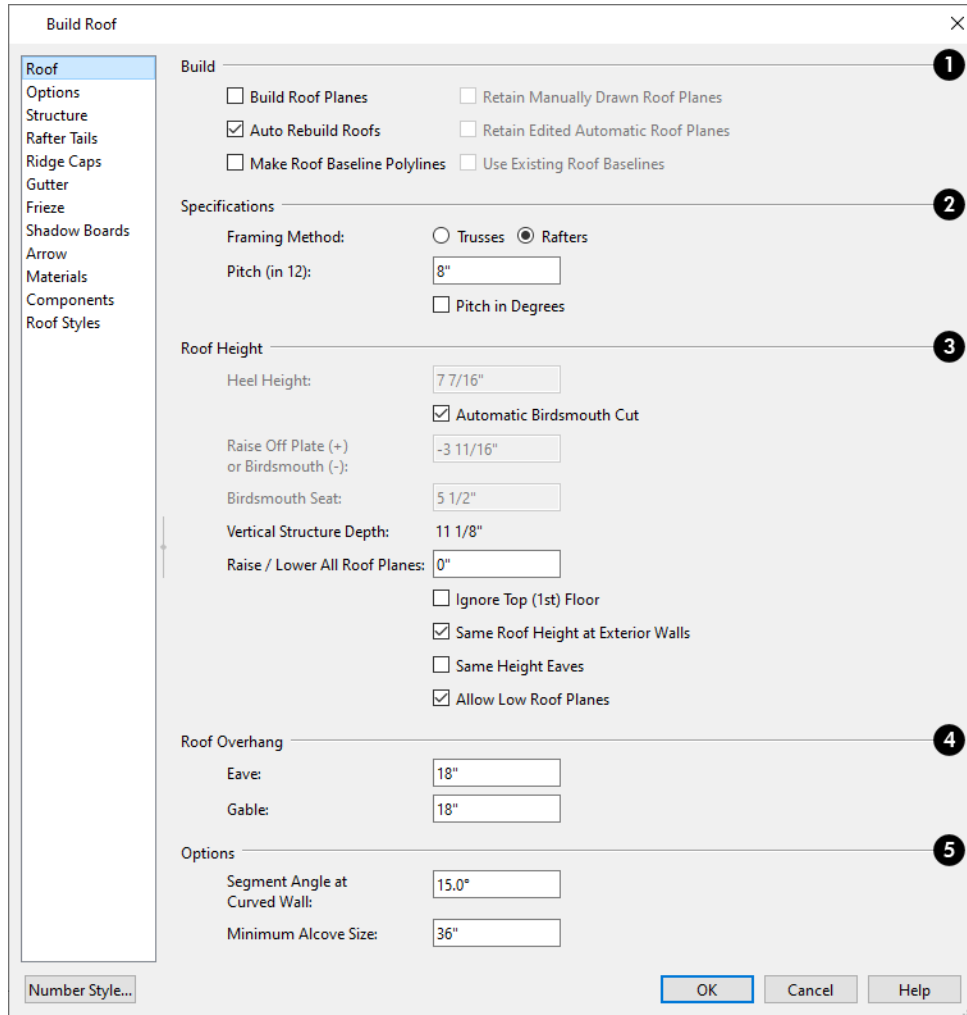

### 1 Build

- Check **Build Roof Planes** to build a new roof structure over the entire model. Unless you specify otherwise, the program discards the existing roof planes and produces new ones.
- If you check **Auto Rebuild Roofs**, the program automatically rebuilds the roof whenever you make a change that affects the generation of roofs, such as changes to exterior walls or ceiling heights.
- Check **Make Roof Baseline Polyline(s)** to delete the existing roof and to create Roof Baseline Polyline(s) based on the exterior wall layout and roof information defined in those walls. Not available when **Build Roof Planes** is checked. See *Roof Baseline Polyline(s) on page 819*.
- You can also specify how manually drawn or edited roof planes are handled when the roof is rebuilt automatically. These options are only available when **Build Roof Planes** is checked. See *Rebuilding Roofs on page 796*.
- Check **Retain Manually Drawn Roof Planes** to prevent manually drawn roof planes from being deleted when roof planes are rebuilt. Automatic roof planes may be generated in the same location. Also available if **Make Roof Baseline Polyline(s)** is checked.

- Check **Retain Edited Automatic Roof Planes** to prevent automatic roof planes that have been manually edited - including roof planes over exploded dormers - from being deleted when roof planes are rebuilt. Also available if **Make Roof Baseline Polylines** is checked.

If a newly generated roof plane is coplanar with a retained plane, and the area where they overlap is at least half the area of either of them, the new roof plane is deleted and only the retained plane is kept.

Note: Under some conditions, new roof planes may be generated in the same location as manually drawn or automatic roof planes that have been retained.

- Check **Use Existing Roof Baselines** to produce a roof plan based on your Roof Baseline Polyline(s) instead of the exterior wall layout.

## 2 Specifications

- Specify the roof **Framing Method**: either **Trusses** or **Rafters**. When Trusses is selected, roof plane Structure Thickness is derived from the default Top Chord Depth for roof trusses set in the Framing Defaults dialog; when Rafters is selected, the Structure Thickness is derived from the default Structure Definition. See *Trusses Panel on page 872* and *Roof Panel on page 869*.
- Enter a value to describe the **Pitch**. In plans using U.S. units of measurement, pitch is described as a ratio over 12 by default; in metric plans, it is measured in degrees. For a conversion to degrees, see *Roof Pitches in Degrees on page 849*.
- Check **Pitch in Degrees** to display the pitch value in degrees in all dialogs as well as in roof plane labels. Values between -89° and 89° can be entered. When **Pitch in Degrees** is unchecked, Pitch is described in terms of rise and run: x inches in 12 or x mm in 1000.
- Check **Trusses (no Birdsmouth)** if you wish to frame the roof using trusses rather than rafters. The roof height will be set so that the bottom edge of the truss top chord is flush with the top of the wall. See *Roof Trusses on page 895*.
- If you plan to use both trusses with rafters, leave **Trusses (no Birdsmouth)** unchecked so that the rafters' depth can be accommodated. See *Mixing Trusses with Stick Framing on page 902*.

## 3 Roof Height

- Specify the **Heel Height**, which is the height that the roof is raised off the wall top plates to accommodate an Energy Heel. Only available when Trusses is the selected Framing Method. See *Energy Heels on page 909*.
- Uncheck **Automatic Birdsmouth Cut** to enable the settings below. When checked, the birdsmouth is calculated based on the pitch and rafter depth and its values are listed here for reference. Only available when Rafters is the selected Framing Method. See *Birdsmouth Cut on page 809*.
- The Raise Off Plate and Birdsmouth settings do not affect the bearing wall heights.
- Enter a positive **Raise Off Plate** value in this field to build the roof to bear on Attic knee walls. A value of 6" builds the roof 6" above the wall top plates, bearing on short Attic walls.
- Enter a negative **Birdsmouth Cut** value to control the birdsmouth depth. For a birdsmouth depth of 3", enter -3". The location of the Baseline may change if you use the **Raise Off Plate** setting to specify the birdsmouth depth. See *Birdsmouth Cut on page 809*.
- Specify the **Birdsmouth Seat**, which is the horizontal depth of the birdsmouth cut. If you change this value, the **Raise Off Plate/Birdsmouth Cut** value will automatically adjust.

- To control the Birdsmouth Cut, you should also check **Same Roof Height at Exterior Walls**, above.
- The **Vertical Structure Depth** is reported here for reference. It can be changed on the STRUCTURE panel. See [Structure Panel on page 803](#).
- Specify the amount to **Raise/Lower All Roof Planes**, which controls the height of roof planes relative to the ceiling height specified for the rooms below. See [Floor and Ceiling Heights on page 426](#).
- The default value is 0, which creates roof planes that bear on the wall top plates at the Ceiling Height of the room below.
- Increase this value to raise roof planes so they do not bear directly on the wall top plates. If roofs are raised sufficiently, Attic walls will automatically generate to support them. The exact height depends on the roof pitch.
- Decrease this value to drop roof planes downward and decrease the height of the bearing walls. If roofs are lowered sufficiently, they may extend into rooms, producing areas with angled ceilings.
- Check **Ignore Top Floor** to ignore the top living floor when roof planes are generated. Roof planes are built on the top plates of the walls below the top floor.
- Specify how you would like the eaves of roof planes with different pitches to meet. See [Aligning Eaves on page 813](#).
- Check **Same Roof Height at Exterior Walls** to keep bearing walls the same height and change horizontal roof overhang distances as needed so that eaves meet correctly.
- When checked, this option ignores any overhang values you may have entered in the Wall Specification dialog. See [Aligning Eaves on page 813](#).
- Uncheck this option to raise or lower some roof planes relative to the wall's top plate, allowing all horizontal overhangs to be the same unless a non-default value has been entered in the Wall Specification dialog. See [Roof Directives in Walls on page 378](#).
- Check **Same Height Eaves** to keep the eave height for all roof planes the same. Roof planes are raised and lowered as needed so that eaves meet correctly.
- The eave height used when this box is checked is that of a roof plane using the default Pitch and Overhang values. When this box is checked, all roof planes are affected, including those that do not need adjustment in order to align with adjacent planes.
- When **Same Height Eaves** is checked, any non-default overhang values specified in the Wall Specification dialog are used. Roof planes are raised or lowered so that the eave height is the same, regardless of the horizontal overhang.
- Uncheck **Allow Low Roof Planes** only when an upper floor overhangs roof planes below.

#### **4** Roof Overhang

An overhang is measured horizontally from the outside Main Layer of exterior walls to the top outside edge of the fascia or shadow boards or, if no fascia or shadow boards are present, the end of the top of the rafter. The overhang does not include frieze molding or gutters. See [The Main Layer on page 385](#).

- **Eave** is the overhang distance outside bearing walls for roof planes using the default Pitch. If a particular roof plane has a different Pitch, its overhang will adjust to keep its fascia at the same height. Overhang may be greater for a shallower pitch, lesser for a greater pitch.
- **Gable** is the overhang distance at gable ends or rake walls.



 If the roof overhang values are not sufficient to extend past the outer surface of exterior walls, the walls may not generate correctly in 3D views.

## 5 Options

- Enter the **Segment Angle at Curved Wall**, which is the angle for roof segments automatically generated to cover a curved wall. A smaller angle produces more roof planes. Note that in some instances, slightly smaller or larger values will be used instead of the specified angle.
- Specify the **Minimum Alcove Size**, which is the minimum depth and width of an alcove in an otherwise straight exterior wall. Alcoves with both a depth and width less than this value are roofed over, while alcoves that are either wider or deeper than this value do not receive a roof.

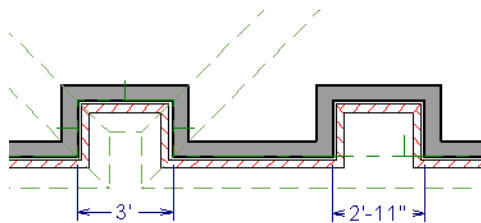

## OPTIONS PANEL

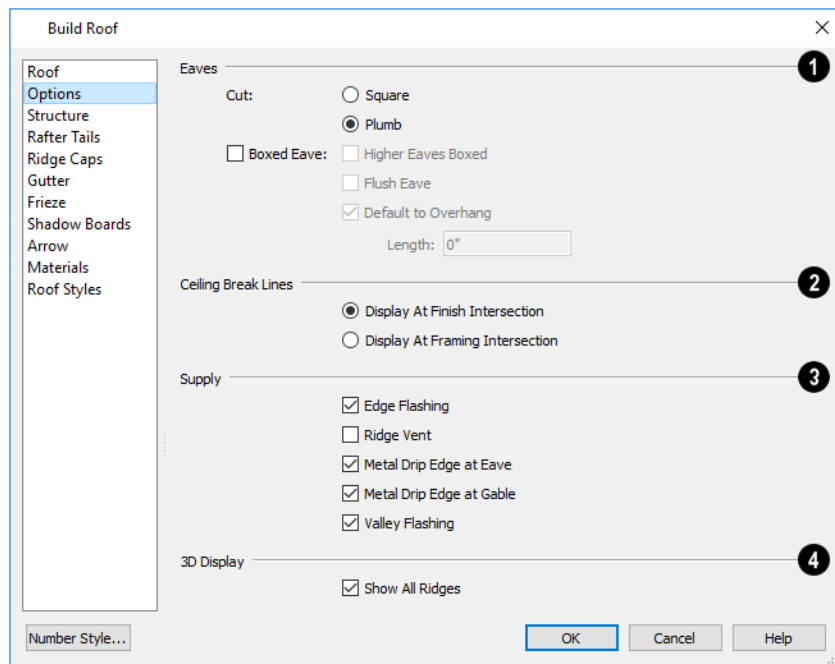

## 1 Eaves

- Specify how the rafter and truss ends are **Cut** by selecting either **Square Cut** or **Plumb Cut**.
- Check **Boxed Eave** to produce horizontal boxed eaves or uncheck it for sloping eaves. You can also change this for individual roof planes in the Roof Plane Specification dialog. See *Boxed Eaves on page 845*.

- Check **Flush Eave** to produce box eaves that build flush with the adjacent exterior wall. When unchecked, boxed eaves build to the gable fascia.
- **Higher Eaves Boxed** - If the selected roof plane contains more than one eave, check this box to box the higher eaves as well as the lower ones.

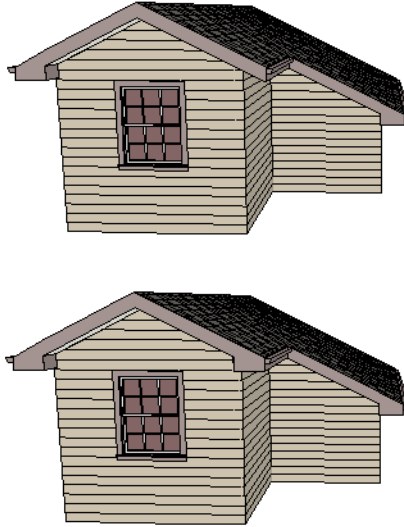

- By default, Boxed Eaves extend from the inside edge of the roof fascia to the exterior Main Layer of the wall, enclosing the overhang area. If an exterior room with **Use Soffit Surface for Ceiling** checked is located between the roof's baseline and an interior room, the Boxed Eave will extend across that room, as well. You can instead uncheck **Default to Overhang** and specify the **Length** of the boxed eaves. Not available if **Flush Eave** is checked.

## 2 Ceiling Break Lines

See *Special Ceilings on page 434*.

- **Display At Finish Intersection** positions ceiling break lines where the ceiling finish surfaces intersect.
- Select **Display At Framing Intersection** to position ceiling break lines where the ceiling framing surfaces intersect.
- When **Use Room Ceiling Finish** is checked, the ceiling finish thickness and material on the undersides of roof planes are defined by the room below. Uncheck this box to enable the two settings that follow and define the ceiling finish as part of the roof planes instead. When this is unchecked, you can specify the Ceiling Surface material on the *Materials Panel on page 804*.
- Check **Has Ceiling** to enable the Ceiling Thickness option. When this box is unchecked, the selected roof plane will have no ceiling surface at all and the "Ceiling Surface" component will not be available on the MATERIALS panel.
- Specify the **Ceiling Thickness**, which is the thickness of the bottom surface of the ceiling plane.

## 3 Supply

Specify which material components to calculate in the Materials List. See *Materials Lists on page 1303*.

- Uncheck **Gutter** to not include gutters on subsequently-built roof planes. This option affects both the Materials List and 3D views.
- Check **Edge Flashing** to calculate edge flashing in the Materials List when one or more roof planes is against a wall.

- Check **Ridge Vent** to calculate ridge venting in the Materials List.
- Check **Metal Drip Edge at Eave** to calculate metal drip edge along the eaves in the Materials List.
- Check **Metal Drip Edge at Gable** to calculate metal drip edge along any gable eaves in the Materials List.
- Check **Valley Flashing** to calculate valley flashing in the Materials List when two or more roof planes form a valley.

#### **4** 3D Display

- When **Show All Ridges** is checked, a line along each hip between roof planes forming the conical roof above a curved wall displays in Vector Views. Uncheck this box to suppress these lines. See *Rendered and Vector Views on page 1080*.

### **STRUCTURE PANEL**

The settings on the STRUCTURE panel of the Build Roof dialog are the same as those on the ROOF panel of the Build Framing dialog. Changes made in one dialog are also applied in the other. See *Roof Panel on page 869*.

Note: Changes made on the Structure panel will not affect the structure of existing roof planes. To make changes take effect, rebuild the roof.

### **RAFTER TAILS PANEL**

The settings on the RAFTER TAILS panel allow you to specify a rafter tail profile for exposed rafter ends under roof eaves. See *Rafter Tails on page 847*.

The settings on this panel are like those on the MOLDINGS panel found in a variety of dialogs in the program. See *Moldings / Profiles / Rails / Panels on page 927*.

A few things about the RAFTER TAILS panel are unique:

- Only one rafter tail profile can be specified at a time, so the **Add New** button is only available when no profile is currently selected.
- Uncheck **Stretch to Fit Rafter** to use the rafter tail profile's default size or to specify its **Height** and **Width**, below. When checked, the profile is sized by the program to match the roof rafters.
- Specify the distance that the rafter tail profile should **Extend** past the inside surface of the subfascia. This distance is measured along the top of the rafter tail, so it is greater than the length as measured in plan view.

### **RIDGE CAPS PANEL**

The settings on the RIDGE CAPS panel allow you to specify a profile for ridge caps. See *Ridge Caps on page 848*.

The settings on this panel are like those on the MOLDINGS panel found in many dialogs in the program. See *Moldings // Profiles / Rails / Panels on page 927*.

### **GUTTER PANEL**

The settings on the GUTTER panel allow you to specify a gutter profile for the eaves of roof planes. See *Gutters on page 846*.

The settings on this panel are like those on the MOLDINGS panel found in many dialogs in the program. See *Moldings // Profiles / Rails / Panels on page 927*.

### **FRIEZE PANEL**

The settings on the FRIEZE panel allow you to specify one or more frieze molding profiles to generate under the eaves and/or gable overhangs of roof planes. See [Frieze Molding on page 847](#).

The settings on this panel are like those on the MOLDINGS panel found in many dialogs in the program. See [Moldings // Profiles / Rails / Panels on page 927](#).

### **SHADOW BOARDS PANEL**

The settings on the SHADOW BOARDS panel allow you to specify one or more shadow board profiles that follow the fascia on eaves and/or gable eaves. See [Shadow Boards on page 846](#).

The settings on this panel are like those on the MOLDINGS panel found in many dialogs in the program. See [Moldings // Profiles / Rails / Panels on page 927](#).

### **ARROW PANEL**

The settings on this panel allow you to control the appearance of roof plane slope direction arrows. See [Displaying Roofs on page 806](#).

For information about these settings, see [Arrowheads on page 327](#).

### **MATERIALS PANEL**

The settings on this panel allow you to specify the default materials for the roof's various components. Some of these materials, as well as their thicknesses, can be specified on the STRUCTURE panel. See [Materials Panel on page 1055](#).

### **ROOF STYLES PANEL**

The ROOF STYLES panel provides links to tutorial information about creating different roof styles automatically. Click on a roof style to launch the online Help to a page with information about the roof style you selected.

### **COMPONENTS PANEL**

The information on the COMPONENTS panel can be used in the materials list. For more information, see [Components Panel on page 1330](#).

---

## **Roof Planes**

When creating a roof, it is helpful to know how to draw a roof plane manually and be familiar with its parts.

### **DRAWING ROOF PLANES**





Roof planes are CAD-based objects that are created and edited like much closed polylines, and also have pitch, elevation and structural properties.

Before drawing roof planes, you should set your roof defaults so that the 3D attributes of your roof planes are correct. See [Roof Defaults on page 792](#).

### To draw a roof plane

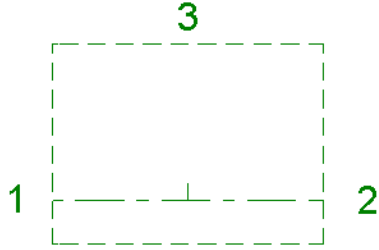
1. Select **Build> Roof> Roof Plane** .
2. Click and drag a Baseline from point **1** to point **2**, as in the following example:



 Most roof planes are drawn over a wall, and the Baseline should be located directly above the outer edge of the wall's Main Layer. See *The Main Layer on page 385*.

3. Release the mouse button at point **2** and move your cursor in the upslope direction. As you move the cursor, a preview outline of the roof plane displays.
4. Click at point **3** to build the roof plane. Point 3 is located on the ridge edge of the roof plane.

Note: You cannot manually draw roof planes when Auto Rebuild Roofs is enabled in the Build Roof dialog. See *Roof Panel on page 798*.

### THE BASELINE

The pitch direction and initial height of any roof plane - manual or automatic - is determined by its Baseline.

The Baseline of the roof plane is normally located over the outer main layer of the wall and is used as the pivot point for the roof plane when the pitch is changed.

The Baseline height is determined by the following formula:

$$\text{Elevation of the wall top plate} + (\text{Vertical Structure Depth} - \text{Vertical Birdsmouth Depth}) = \text{Baseline Height}$$

In a cross section, the Baseline is located directly above the outer surface of the main wall layer, at the top surface of the roof framing.

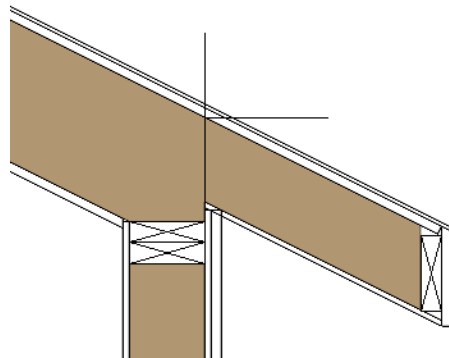

A roof Baseline displays as a separate line within its roof plane when the "Roofs, Baselines" layer is turned on. In 3D views, it can only be seen if the roof plane is selected.

A Baseline has a tick mark at its center point which indicates the direction that the roof plane slopes upward. If the upslope tick is pointing the wrong direction, either rotate the entire roof plane or delete it and draw a new one.

When drawing the Baseline of a roof plane, here are some things to consider:

- A Baseline does not have to be drawn over a wall, although it often is.
- A Baseline drawn along a wall should be drawn over the outer edge of the wall's main layer. It tries to snap to that layer.
- The elevation of the top plate is defined by the ceiling height in the room. If the roof plane is not drawn over a wall, its height is based on the default ceiling height value for the current floor.
- If a Baseline is drawn over the top of any other roof plane, the Baseline height equals the height of the existing roof plane at the point where you started drawing.

Once drawn, a Baseline can be selected in plan view and edited independent of the roof plane. See [Editing Roof Baselines on page 810](#).

## EAVE AND GABLE OVERHANGS

Roof overhangs are measured horizontally from the outside Main Layer of exterior walls to the top outside edge of the fascia or shadow boards or, if no fascia or shadow boards are present, the end of the top of the rafter. The overhang does not include frieze molding or gutters. See [The Main Layer on page 385](#).

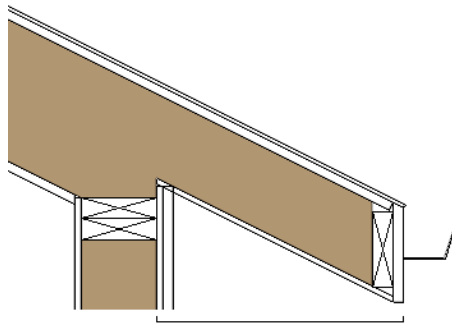

The location of a roof plane's fascia and shadow boards also determines its area and the size of its polyline in plan view. See [Polyline Panel on page 818](#).

## ROOF LAYERS

Each roof plane is composed of Surface, Structure, and Ceiling Finish layers. These can be specified in the Build Roof dialog. See [Structure Panel on page 803](#).

---

# Displaying Roofs



The display of roof planes, their labels, and attributes such as gutters and ridge caps is controlled in the Layer Display Options dialog or Active Layer Display Options side window. See [Layer Display Options Dialog on page 179](#).

Roof planes are drawn on the "Roof Planes" layer by default. If this layer is turned off and **Auto Rebuild Roofs** feature is turned on, changes made to the plan that cause the roof to rebuild will not automatically turn on its display. See [Rebuilding Roofs on page 796](#).

## IN PLAN VIEW

A number of layers associated with roof planes only display information in plan view, including "Roofs, Baselines" and "Roofs, Gable Lines".

If the bottom surface of the roof extends below the ceiling height of a room, Ceiling Break lines will display, indicating where the flat ceiling ends and sloped ceiling begins. Ceiling Break lines are drawn on the "Ceiling Break Lines" layer in plan view only.



In plan view, roof planes can display on any floor without affecting their height in 3D. To move the display of a roof plane to a new floor, select it in plan view and click either the **Display on Floor Above** or **Display on Floor Below** edit button. The display of group-selected roof planes can also be controlled in this manner.



Any skylights or roof holes placed in a roof plane moved in this manner will move, as well. Other associated objects like Auto Dormers or gutters will not move, however.

## ROOF PLANE LABELS

Roof plane labels indicating the pitch and slope direction are located on the "Roofs, Labels" layer and can be set to display in floor plan and cross section/elevation views. When a roof plane or a ceiling plane with a label specified is selected, its label will have a small square Move handle and small rectangular Rotate handle for the text only.

You can specify whether roof plane labels display the pitch in terms of rise and run or in decimal degrees by checking or unchecking **Pitch in Degrees** in the Build Roof dialog. See [Roof Panel on page 798](#).

A roof plane's label can be customized in its specification dialog. See [Label Panel on page 700](#). Roof planes have named value pairs associated with them, so you can create custom labels using Text Macros. See [Text Macros on page 540](#).

Manually drawn **Ceiling Planes**  and **Skylights**  can also display labels when the "Roofs, Labels" layer is on. Unlike roof planes, these objects' labels do not include a slope indicator and their Automatic Labels are blank; however, you can specify a custom label using text in their specification dialogs. See [Ceiling Planes on page 826](#) and [Skylights and Roof Holes on page 834](#).

When a roof plane, ceiling plane or roof hole/skylight is selected in a 3D view, its label will display on a temporary basis if the "Roofs, Labels" layer is turned on.

## IN CROSS SECTION AND CAMERA VIEWS

When a roof or ceiling plane is viewed in a cross section, the layers that compose it can be seen, including the roof surface, sheathing, and the ceiling surface:

- If roof framing has been built, its display can be turned on, as well. See [Displaying Framing on page 879](#).
- If a roof or ceiling plane is located over a room with **Flat Ceiling Over this Room** checked, the ceiling surface will not generate. See [Vaulted and Cathedral Ceilings on page 435](#).
- The layers of roof and ceiling planes can be detailed using the **Auto Detail**  tool. See [Detailing Cross Section/Elevation Views on page 1094](#).

In camera views and overviews, the appearance of curved roof planes can be controlled by adjusting the **Facet Angle** in the Roof Plane Specification dialog. See [General Panel on page 814](#).

## IN THE MATERIALS LIST

The materials that make up roof and ceiling plane assemblies are listed under different Categories in the Materials List:

- **Roofing** - Lists most materials associated with roofs, including roofing, sheathing, rafters and trusses, gutters, and skylights.
- **Exterior Trim** - Lists automatically generated frieze molding and shadow boards. See *Roof Returns and Other Details on page 844*.
- **Insulation** - Insulation is calculated for roof and ceiling planes above rooms that do not have Flat Ceiling Over This Room checked. See *Structure Panel on page 439*.
- **Wallboard** - Lists ceiling materials for all rooms, including those that use the underside of the roof as their ceiling.
- **Framing** - Lists ceiling framing for manually drawn ceiling planes.

See *Materials Lists on page 1303*.

## IN SCHEDULES

Roof Planes, Roof Holes, Skylights, and a selection of Roof Trim items can be included in schedules. See *The Schedule Tools on page 682*.

Roof Holes and Skylights are listed in the "Windows" category by default, while Frieze, Gutter, Ridge Cap, and Shadow Boards are listed in the "Roof Trim" category. You can, however, assign a selected roof object to the category of your choice in its specification dialog. See *Schedule Panel on page 704*.

---

# Editing Roof and Ceiling Planes

A selected roof or ceiling plane can be edited in 2D and 3D using edit handles, edit toolbar buttons, and its specification dialog. In 3D views, you can also use the **Material Painter** . See *Material Painter Tools on page 1052*.

A roof or ceiling plane's Baseline can also be selected and edited. To select it, first select the roof plane and then click the **Select Next Object**  edit button. See *The Baseline on page 805*.

The appearance and display of roof and ceiling planes can also be customized. See *Displaying Roofs on page 806* and *Roof Plane Specification Dialog on page 814*.

By default, all roof planes are deleted and replaced whenever the roof is rebuilt using the Build Roof dialog. If you have manually edited roof planes and do not want them to be replaced, be sure to check **Retain Edited Roof Planes**. See *Roof Panel on page 798*.

 Roof planes cannot be edited while Auto Rebuild Roofs is turned on. If you try to do so, the program will prompt you to turn it off. If you use the Material Painter to edit a component of a roof plane while Auto Rebuild Roofs is on, you will be prompted to either turn it off or update the default material for that component.

## 2D SHAPE AND 3D ORIENTATION

There are two basic aspects to editing roof planes: 2D shape and 3D orientation.



- The 2D shape of a roof or ceiling plane can be edited much like a closed CAD polyline. As a plane's perimeter is reshaped in 2D, the program maintains its height and pitch in 3D. See [Editing Closed Polyline-Based Objects on page 228](#).
- The 3D orientation of a roof or ceiling plane is defined by its height, pitch, and its structure: all of which can be edited in its specification dialog.

An understanding of these two concepts allows you to design almost any kind of roof system.

## RAISING/LOWERING ROOF AND CEILING PLANES

The default height of a roof or ceiling plane is based on the ceiling height of the room below. See [Floor and Ceiling Heights on page 793](#).

 Roof planes can be raised or lowered in the Roof Plane Specification dialog. Begin by locking the **Pitch**, then change one of the **Height** values. See [General Panel on page 814](#).

Ceiling planes can be edited in a similar manner in their specification dialog. See [General Panel on page 828](#).

 You can also raise or lower roof and ceiling planes using the **Transform/Replicate Object** edit tool. See [Transform/Replicate Object Dialog on page 266](#).

In addition, when a new floor is added to a plan, you can choose to move any roof planes displaying on the top floor up to the newly added floor level. Ceiling planes are not affected when a new floor is added. See [Adding Floors on page 732](#).

## CHANGING A ROOF OR CEILING PLANE'S PITCH

The default pitch for a roof system as well as for manually-drawn ceiling planes is set in the Build Roof dialog. Non-default pitches can be set in the specification dialog of each exterior bearing wall defining a room on the top floor level of the plan. See [Roof Directives in Walls on page 378](#).

 Just as with its height, the pitch of a roof or ceiling plane can be modified on the GENERAL panel of its specification dialog. Begin by locking one of the **Height** values and then change the **Pitch**.

If you choose to lock the **Top of Plate** height of a roof plane, the point about which the plane will pivot depends on whether **Automatic Birdsmouth Cut** is checked in the Build Roof dialog.

- When it is checked, the roof plane will pivot about the top inside edge of the bearing wall's top plate.
- When it is unchecked, it will pivot about the top outside edge of the top plate.

Changing a roof plane's pitch can affect how it connects to adjacent roof planes. See [Connecting Roof and Ceiling Planes on page 811](#).

## EDITING ROOF PLANE STRUCTURE

To create roof planes of a particular depth, begin by setting up the desired roof framing defaults, then build the roof. See [Framing Defaults on page 851](#).

If you later need to change the structure of the roof planes, make the needed change to the Framing Defaults, and then rebuild the roof. You can also edit roof structure on an individual roof plane basis. See [Roof Plane Specification Dialog on page 814](#).

## BIRDSMOUTH CUT

The birdsmouth is the notch cut into a rafter where it rests on the wall top plate. You can control its vertical depth and the width of the birdsmouth seat in the Build Roof dialog. See [Roof Panel on page 798](#).

There are two ways to create a roof plane with no birdsmouth:

- Check **Trusses (No Birdsmouth)** in the Build Roof dialog before drawing the roof plane.
- Specify a **Raise Off Plate** value of at least 1/16” in the Build Roof dialog.

To change the birdsmouth depth after the roof is built, you can move the roof planes up or down, or change the pitch. For example, if you lock the pitch and raise the roof plane by one inch, you decrease the birdsmouth depth by one inch.

## EDITING ROOF BASELINES

The pitch direction and initial height of any roof plane - manual or automatic - is determined by its Baseline. See [The Baseline on page 805](#).

In plan view, a Baseline can be selected and edited independent of the roof plane. To select it, click on the roof plane at the location of the Baseline and then click the **Select Next Object**  edit button. The Status Bar tells you when the roof plane Baseline is selected. See [Select Next Object on page 211](#).

If a roof plane Baseline is moved, its height will not change. Instead, the height of the roof plane will be affected. In most cases, therefore, moving a roof plane’s Baseline independent of the roof plane itself is not recommended.

If the angle of a roof plane’s Baseline is changed, the direction of the roof plane’s pitch will be modified. The Baseline Angle can be modified in either of two ways:

- In the Roof Plane Specification dialog. This will change its angle relative to the floor, and will tilt the roof plane along an axis perpendicular to its Baseline. This method is helpful when a specific eave angle is needed. See [General Panel on page 814](#).
- Using its Rotate edit handle in plan view. This will change its angle relative to the roof plane’s eave or ridge and will modify the direction of the pitch. This method is best when the pitch direction matters more than the angle of the eave.
- Both of these methods can be used to modify the same roof plane, although the second approach makes it difficult to control both the pitch direction and eave angle, and is not recommended.

The length of a roof plane Baseline can be lengthened or shortened using its edit handles without changing any of the roof plane’s attributes.

## ROOF EDGES AND WALLS

By default, the edges of a roof plane will automatically snap to the outer surface of a nearby parallel wall. You can disable this **Special Snapping** behavior for a selected roof plane in its specification dialog. See [General Panel on page 814](#).

After moving a corner edit handle, it may be difficult to make an edge parallel to an eave or a wall. Use the **Make Parallel/Perpendicular**  edit button to align a roof or ceiling plane edge with a wall, another roof plane edge, or another object with a straight edge. See [Make Parallel/Perpendicular on page 250](#).

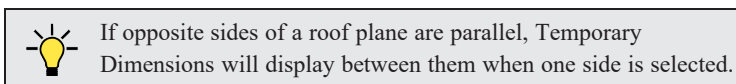

Sometimes, what appears to be a single, straight roof plane edge may actually be broken into two or more edges, which can affect your ability to align the edge properly.

A single edge will have three edit handles; if more than three display, more than one edge is present. An extra handle can be removed manually by dragging it into an adjacent handle. You can also use **Build> Roof> Fix Roofs** . See [Fix Roofs on page 795](#).

When **Bumping/Pushing**  is enabled and **CAD Stops Move** is checked in the Roof Plane Specification dialog, a roof plane will bump against another roof plane, CAD or CAD based object as it is moved. Roof planes cannot push these objects, however. See *Bumping/Pushing on page 243*.

## LOCKING ROOF PLANES

When the roof plan is correct, roof planes can be locked to prevent accidental changes. To do this, lock the “Roof Planes” layer in all layer sets. See *Layer Display Options Dialog on page 179*.

Locking roof planes will not prevent roof planes from being deleted if the floor they are on is deleted.

## DELETING ROOF PLANES

There are several ways to delete roof planes.



Delete the entire roof quickly by selecting **Build> Roof> Delete Roof Planes**.



You can also delete all roof planes at once in the Delete Objects dialog. See *Delete Objects Dialog on page 285*.



In addition, you can select any roof plane or group of roof planes, then press the Delete key or click the **Delete** edit button to delete it from the plan. See *Deleting Objects on page 284*.

Generally speaking, roof planes cannot be deleted if they are locked. An exception to this rule occurs when an entire floor of a plan is deleted. Any roof planes present on a floor will be deleted when the floor is deleted, locked or not. See *Deleting Floors on page 735*.

When a roof plane is deleted, any roof framing associated with it is automatically deleted, as well.

---

# Connecting Roof and Ceiling Planes

When a roof system is drawn correctly, roof planes will meet along geometrically correct lines to form ridges, hips, and valleys. There are a number of tools to help you achieve this when manually drawing or editing roofs.

To generate roof planes that do not form a single, integrated system, consider using Roof Groups. See *Roof Groups on page 795*.

By default, all roof planes are deleted and replaced whenever the roof is rebuilt using the Build Roof dialog. If you have manually edited roof planes and do not want them to be replaced, be sure to check **Retain Edited Roof Planes** in the Roof Plane Specification dialog. See *Roof Panel on page 798*.



Roof planes cannot be edited while Auto Rebuild Roofs is turned on. If you try to do so, the program will prompt you to turn it off.

## JOIN ROOF PLANES



Two roof or ceiling planes can be joined at adjacent edges in both 2D and 3D using the **Join Roof Planes** edit button.

To use this tool, first identify which edges of the roof planes can extend to meet at a ridge, hip, or valley. The program will join the two planes along the line where they intersect whenever possible.

### ***To use Join Roof Planes***

1. Select a roof or ceiling plane on the edge to be joined to another plane.
2. Click the **Join Roof Planes**  edit button (or press 2 on the keyboard).
3. Move your pointer to the edge of the second roof or ceiling plane that the first one needs to join to. When your pointer is over the second plane, this plane will highlight.
4. Click on the edge of the second roof or ceiling plane to join it to the first plane.

Note: Join Roof Planes cannot be used to join a roof plane and ceiling plane. Only planes of the same type can be joined using this tool.

If the planes are not close enough, or their shape is not correct, you may need to align their edges, remove extra edges, or move them closer.

When roof or ceiling planes adjust, the program joins them at the proper location and the adjacent edges extend or contract to remain connected. If the joining of the two will completely eliminate or reverse an adjacent edge, the connection cannot be made.

### **LOCATING INTERSECTIONS**

When roof planes of differing slopes meet, they create a ridge, hip, or valley. The **Join Roof Planes**  edit tool is the easiest way to move roof plane edges so that they meet correctly; but you can also locate roof plane intersection points where the ridge, hip or valley should be. Once you know where the planes will meet, you can drag edges or corners to those points.

### ***To find roof plane intersection points***

1. Select the roof plane you would like to place intersection points on.
2. Click the **Place Roof Plane Intersection Point**  edit button.
3. Click the edge of another roof plane to place a temporary CAD Point at the geometrically accurate location where that edge would meet the selected roof plane.
4. Repeat these steps for additional edges as needed.

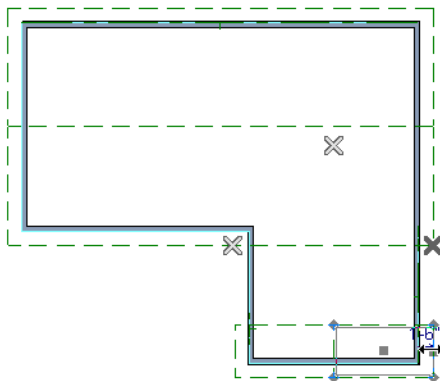

5. Once these intersection points are identified, you can snap the corners of the second roof plane to them.

## ALIGNING EAVES

It is not uncommon for roof plans to feature more than one pitch. In order for the eaves of roof planes with different pitches to meet correctly at ridges and hips, you must control the roof planes' heights and their horizontal overhang distances. Two options in the Build Roof dialog allow you to control how the eaves of automatically generated roof planes align. See *Roof Panel on page 798*.

- **Same Roof Height at Exterior Walls** maintains the default height of roof planes where they bear on exterior walls. The horizontal overhang distances of any non-default roof planes are adjusted so that they continue to join correctly with default roof planes.
- **Same Eave Heights** maintains the default roof plane height at the eaves as well as any non-default horizontal overhang distances. All roof planes are raised or lowered so that they all have the same height at the eaves as default roof planes.

Roof planes that do not join other roof planes with different pitches at ridges or hips are referred to as Independent.

- When **Same Roof Height at Exterior Walls** is checked, Independent roof planes are not affected and will maintain any non-default overhang values.
- When both **Same Roof Height at Exterior Walls** and **Same Eave Heights** are checked, the overhangs of Independent roof planes will be adjusted to preserve their heights at both the exterior walls and the eaves.

## MOVE TO BE COPLANAR



The **Move to be Coplanar** edit button allows you to move the selected roof plane to be coplanar (in the same plane) with the next selected roof plane. You can use this tool in both 2D and 3D views. The results can be easily seen in a cross section view. The two roof planes must have parallel Baselines for this to work.

## SET BASELINE HEIGHT DIALOG

If you manually draw a roof plane so that it bears on a wall at its Baseline, and is placed in the same location as an existing roof plane, the Set Baseline Height dialog will display. See *The Baseline on page 805*.

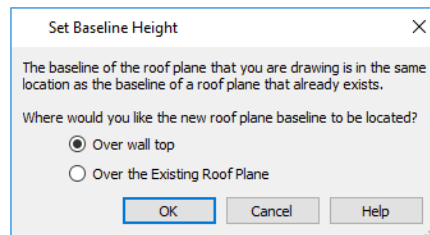

- Select **Over Wall Top** to create a roof plane that bears on the wall it is drawn over and has an overhang as specified in the Build Roof dialog. This option would be appropriate to produce a full height dormer. See *Manually Drawn Dormers on page 839*.
- Select **Over the Existing Roof Plane** to produce a roof plane with a height based on that of the roof plane below it rather than the wall. The Baseline height equals the top height of the existing roof at the point where you began drawing the new roof plane Baseline, and has no overhang. This option would be appropriate to create a dormer vent or cricket. See *Crickets on page 840*.

# Roof Plane Specification Dialog

Select one or more roof planes and click the **Open Object** edit button to open the Roof Plane Specification dialog.

You can also open this dialog for all roof planes in the entire plan by selecting **Build > Roof > Edit All Roof Planes** .

The Roof Plane Specification dialog has the following panels:

## GENERAL PANEL

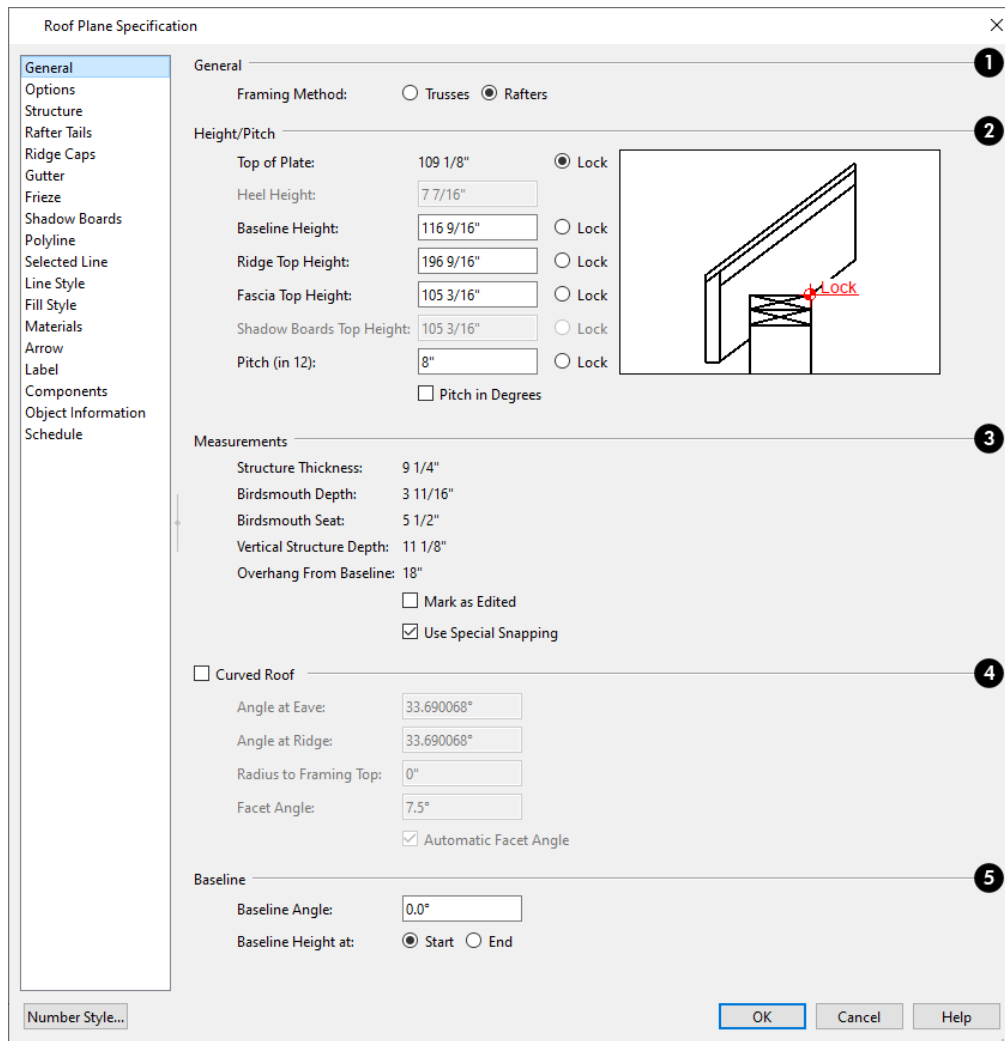

There are four values that define the 3D orientation of a roof plane: **Ridge Top Height, Baseline Height, Fascia Top Height, and Pitch.**

Locking any of the **Height** values defines that value as the pivot point for the selected roof plane. Each of these dimensions is measured from the first floor default elevation of 0' - 0".

If you lock the **Pitch** and change a Height value, the roof plane moves vertically, keeping the same slope. It will not pivot. For a conversion to degrees, see [Roof Pitches in Degrees on page 849](#).

Changing these values does not affect the 2D representation of the roof plane.

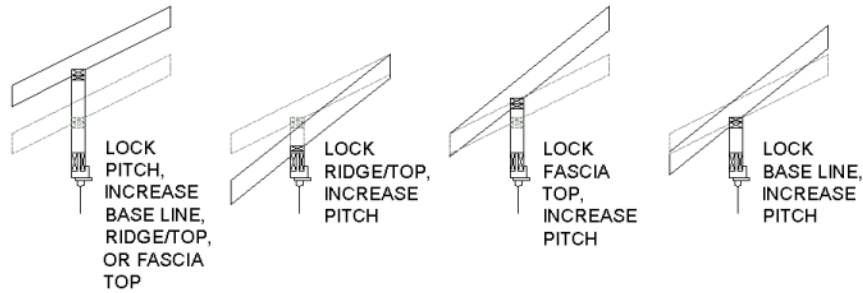

## 1 General

- Specify the selected roof plane's **Framing Method**: either **Trusses** or **Rafters**. When Trusses is selected, the roof plane's Structure Thickness is derived from the default Top Chord Depth for roof trusses set in the Framing Defaults dialog; when Rafters is selected, the Structure Thickness is derived from the dialog. See [Roof Panel on page 869](#) and [Trusses Panel on page 872](#).

## 2 Height/Pitch

Specify the **Height** and **Pitch** of the selected roof plane(s). Heights are measured from the top surface of the roof plane(s) rafters or trusses. See [Roof Planes on page 804](#).

- The **Top of Plate** is defined by the ceiling height of the room below and is reported here for reference. N/A displays if no room is below the roof plane.
- Define the **Ridge Top Height**, or lock this value to make it the roof plane's pivot point. If the roof plane's has multiple ridge lines, this setting is associated with the highest ridge.
- Define the **Baseline Height**, or lock this value to make it the pivot point.
- Define the **Fascia Top Height**, or lock this value to make it the pivot point.

Note: The Fascia Top height will decrease slightly if the fascia edge is aligned with the ridge top of another roof plane.

- Define the **Shadow Board Top** height, or lock this value to make it the pivot point. Only available when Shadow Boards are present on the selected roof plane. See [Fascia and Shadow Boards on page 845](#).
- Specify the **Pitch** for the selected roof plane, or lock this value to move the roof plane vertically when a Height value is changed.
- Check **Pitch in Degrees** to display the pitch value in degrees in all dialogs as well as in roof plane labels. Values between  $-89^\circ$  and  $89^\circ$  can be entered. When **Pitch in Degrees** in unchecked, Pitch is described in terms of rise and run: x inches in 12 or x mm in 1000.

The diagram to the right of the Height/Pitch settings shows the location of the Lock point. If a Height/Pitch setting is currently selected for editing, its location will also be indicated using an arrow.

- By default, the selected **Show Diagram for** option is determined by whether Trusses (no Birdsmouth) was checked in the Build Roof dialog when the selected roof plane was created.
- Select a radio button to choose whether to **Show Diagram for Rafters** or **Trusses**. The structure of the roof and location of the Top of Plate Lock point vary between these two options.

### 3 Measurements

Information about the structure of the selected roof plane(s) displays here for reference.

- The **Structure Thickness** of the selected roof plane(s) is reported here for reference but is specified on the Structure panel. The default Structure Thickness is defined in the Build Framing dialog. See *Build Framing Dialog on page 860*.
- The **Birdsmouth Depth** is the plumb or vertical depth of the birdsmouth cut. To change it, move the roof plane some way. For example, if you lock the pitch and raise the roof plane by one inch, you will decrease the birdsmouth depth by one inch. See *Birdsmouth Cut on page 809*.
- The **Birdsmouth Seat** is the horizontal width of the birdsmouth cut. This value is dynamically linked to the birdsmouth depth - if one changes, so does the other.
- The **Vertical Structure Depth** is defined by measuring a plumb line across the roof plane structure. The degree of pitch affects the Vertical rafter width. The greater the pitch, the greater the vertical structure depth.
- **Overhang from Baseline** is the horizontal overhang measured from the Baseline to the eave.
- **Mark as Edited** - When an automatically generated roof plane is modified, the program marks it as "edited", giving you the option of retaining it when the roof is rebuilt. Uncheck this box to remove this status from the selected roof plane. See *Rebuilding Roofs on page 796*.
- **Mark as Edited** is only available for automatically generated roof planes. If a manually drawn roof plane is selected, the words **Manual Roof Plane** will display here instead.
- When **Use Special Snapping** is checked, the selected roof plane's edges will automatically snap to the outside surface of walls that it may butt against. Uncheck this to prevent the roof plane from snapping to any nearby walls.

### 4 Curved Roof

Check **Curved Roof** to specify the selected roof plane as curved. See *Curved Roof Planes on page 823*.

- Specify the roof plane's **Angle at Eave**, **Angle at Ridge** and **Radius to Roof Surface**.
- These three values are interrelated - when one is changed, the other two adjust accordingly. You may find it helpful to first specify the **Radius** value, then the **Angle** values.
- A flat roof plane with a pitch of 0 has angles of 0 at both the ridge and eave, as well as a radius of 0.
- Uncheck **Automatic Facet Angle** to specify the **Facet Angle**, which is the angle at which curved roof surfaces are broken in 3D views. The default value is 7.5°; a smaller value produces a smoother curve while a larger value may generate more quickly in 3D views.  
The **Facet Angle** value must divide into 360° evenly; if it does not, the program will choose the nearest value that does.

### 5 Baseline

Specify the angle of the selected roof plane's **Baseline**, relative to the XY axis. See *Editing Roof Baselines on page 810*.

- A positive **Baseline Angle** value causes the Baseline to tilt upward from its default height. A negative value causes it to tilt downward. The top heights of any walls under the selected roof plane will become angled, as well.
- The **Baseline Height** defined above can be maintained at either the **Start** or **End** point. In plan view, the Baseline direction is clockwise around the house.



## OPTIONS PANEL

The settings on the OPTIONS panel are the same as those on the panel of the same name in the Build Roof dialog, but affect the selected roof plane only. See *Options Panel on page 801*.

## STRUCTURE PANEL

The settings on the STRUCTURE panel are similar to those on the ROOF panel of the Build Framing dialog, but apply to the selected roof plane only. See *Roof Panel on page 869*.

One check box is unique to the STRUCTURE panel of the Roof Plane Specification dialog: check **Retain Roof Framing** to keep the selected roof plane's framing from being deleted and replaced when roof framing is rebuilt.

## RAFTER TAILS PANEL

The settings on the RAFTER TAILS panel are the same as those on the same panel of the Build Roof dialog, but affect the selected roof plane only. See *Rafter Tails Panel on page 803*.

Most of the settings on this panel are also like those on the MOLDINGS panel found in a variety of dialogs in the program. See *Moldings // Profiles / Rails / Panels on page 927*.

## RIDGE CAPS PANEL

The settings on the RIDGE CAPS panel allow you to specify one or more ridge cap profiles on the ridge and hip edges of the selected roof plane and are the same as those on the same panel of the Build Roof dialog. See *Ridge Caps on page 848*.

If you customize the settings on this panel, bear in mind that your changes may only take effect in the model if the same changes are also made to adjacent roof planes.

Most of the settings on this panel are like those on the MOLDINGS panel found in many dialogs in the program. See *Moldings // Profiles / Rails / Panels on page 927*.

## GUTTER PANEL

The settings on the GUTTER panel allow you to specify a gutter profile for the eaves of roof planes. See *Gutters on page 846*.

The settings on this panel are like those on the MOLDINGS panel found in many dialogs in the program. See *Moldings // Profiles / Rails / Panels on page 927*.

## FRIEZE PANEL

The settings on the FRIEZE panel allow you to specify a frieze molding profile to generate under the eaves of the selected roof plane and are the same as those on the same panel of the Build Roof dialog. See *Frieze Molding on page 847*.

The settings on this panel are like those on the MOLDINGS panel found in many dialogs in the program. See *Moldings // Profiles / Rails / Panels on page 927*.

## SHADOW BOARDS PANEL

The settings on the SHADOW BOARDS panel allow you to specify one or more fascia shadow board profiles that follow the selected roof plane's eaves. See *Shadow Boards on page 846*.

The settings on this panel are like those on the MOLDINGS panel found in many dialogs in the program. See [Moldings // Profiles / Rails / Panels on page 927](#).

## POLYLINE PANEL

The POLYLINE panel states the length of the roof plane's **Perimeter** and its enclosed **Area**, calculated using several different methods.

Roof Plane Specification		
General	Perimeter:	943 11/16"
Options	Framing Area:	294.683 sq ft
Structure	Projected Area:	247.25 sq ft
Rafter Tails	Roof Surface Area:	297.158 sq ft
Ridge Caps	Overhang Area:	54.3133 sq ft
Gutter	Projected Overhang Area:	45.1914 sq ft
Frieze		
Shadow Boards		
Polyline		

- The **Perimeter** is the total length of the roof plane's sides, not including fascia and shadow boards, with its pitch taken into account. It does not equal the perimeter as measured in plan view unless the roof plane has no fascia or shadow boards and the pitch is 0.
- The **Framing Area** is the area of the roof plane's framing, not including the fascia or shadow boards, with the pitch taken into account. It is slightly smaller than the Roof Surface Area as roofing typically overhangs the framing by a small amount.
- The **Projected Area** is the area of the roof plane polyline, including fascia and shadow boards, as seen in plan view. It does not equal the Roof Surface Area unless the pitch is 0.
- The **Roof Surface Area** is the area of the roof plane's top surface, which covers the fascia and shadow boards, with the pitch taken into account.
- The **Overhang Area** is the area of the roof plane's overhang, including fascia and shadow boards, with its pitch taken into account.
- The **Projected Overhang Area** is the area of the roof plane's overhang, including fascia and shadow boards, as seen in plan view.

## SELECTED LINE PANEL

The SELECTED LINE panel is similar to the Line panel of the Line Specification dialog. See [Line Panel on page 304](#).

## LINE STYLE PANEL

For information about the settings on this panel, see [Line Style Panel on page 305](#).

## FILL STYLE PANEL

The settings on the FILL STYLE panel control the appearance of the selected roof plane in plan view. For information about these settings, see [Fill Style Panel and Dialogs on page 193](#).

## ARROW PANEL

The settings on the ARROW panel allow you to control the appearance of the selected roof plane's slope direction arrow. See [Displaying Roofs on page 806](#).

For information about these settings, see [Arrowheads on page 327](#).

## MATERIALS PANEL

The settings on the MATERIALS panel allow you to specify materials for the selected roof plane's various components. For more information, see *Materials Panel on page 1055*.

The "Ceiling Surface" component is only available when **Use Room Ceiling Finish** is unchecked on the STRUCTURE panel.

## LABEL PANEL

Roof plane labels display when the "Roofs, Labels" layer is turned on and use the Text Style assigned to that layer. See *Roof Plane Labels on page 807*.

For information about the settings on this panel, see *Label Panel on page 700*.

## COMPONENTS PANEL

The information on the COMPONENTS panel can be used in the materials list. See *Components Panel on page 1330*.

## OBJECT INFORMATION PANEL

The information entered on the OBJECT INFORMATION panel can be used in schedules and the materials list. For more information, see *Object Information Panel on page 1331*.

## SCHEDULE PANEL

The settings on the SCHEDULE panel determine which schedule categories the selected roof plane is included in. See *Schedule Panel on page 704*.

---

# Roof Baseline Polylines

Typically, the program builds an automatic roof based on the settings in the Build Roof dialog and on the ROOF panel of the Wall Specification dialog, along with the layout of the exterior walls and floor and ceiling heights.

If you want to build a roof that diverges from the footprint of your building as well as the roof directives in the exterior walls, you can use Roof Baseline Polylines.

### *To create roof baseline polylines*

1. Select **Build > Roof > Build Roof** .
2. On the BUILD panel of the Build Roof dialog, check **Make Roof Baseline Polylines**.
3. Click **OK**. A set of roof Baselines is created along the outside edge of the Main Layer of the exterior walls, forming one or more closed polylines.

As with roof planes, the heights of Roof Baseline Polylines are determined by ceiling heights in the plan. If roof planes will be built at more than one height, a separate baseline polyline is created for each height.

Once created, a Roof Baseline Polyline can be edited in a variety of ways, then used as the basis for the roof then next time it is built automatically.

To create a new roof using the directives in your Roof Baseline Polyline(s), check **Use Existing Roof Baselines** in the Build Roof dialog and click OK. See *Roof Panel on page 798*.

## DISPLAYING ROOF BASELINE POLYLINES

Roof Baseline Polylines are placed on the “Roofs, Baseline Polylines” layer by default and use the Text Style assigned to that layer. See *Layer Attributes on page 177*.

Roof directive information displays along each edge of the polyline, including:

- V - vertical (against wall);
- G - gable/shed;
- K - knee wall;
- L - lower (extend slope downward).

If the directive information includes the pitch, the roof plane slopes toward that edge; if it includes the word (vert), it does not.

## EDITING ROOF BASELINE POLYLINES

A Roof Baseline Polyline’s shape can be edited much like a CAD polyline using its edit handles and edit toolbar buttons. See *Editing Closed Polyline-Based Objects on page 228*.

Roof Baseline Polylines always form a closed area with straight sides only. They cannot be severed or curved, but additional joints or corners can be added.

In addition to length and direction, each Roof Baseline Polyline edge has roof directives associated with it, much like the roof directives in individual walls. See *Roof Directives in Walls on page 378*.

## AN EXAMPLE

In order for it to reflect any changes that you make to a Roof Baseline Polyline, the roof must be rebuilt. For a simple example of Roof Baseline Polyline editing, consider an L-shaped house, with a rectangular roof. The inner part of the 'L' is a patio that is covered under the same roof.

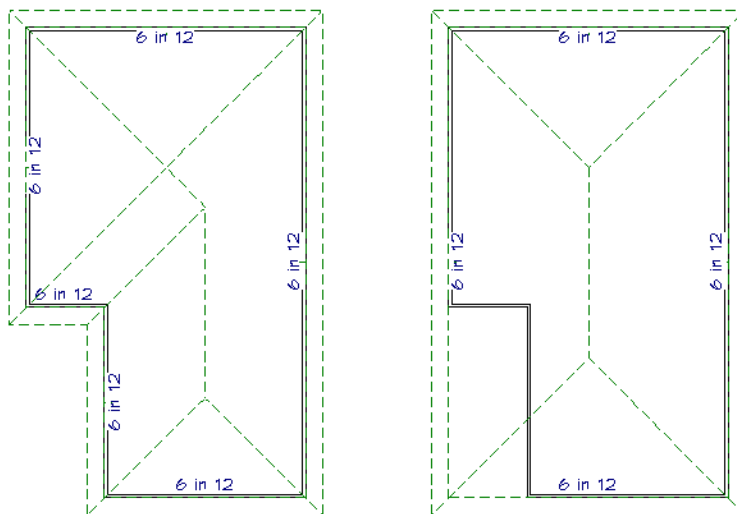

On the left is the baseline polyline as it was originally produced and the roof plan it creates.

**To model the roof plan shown on the right**

1. Select the Roof Baseline Polyline along its bottom-most edge.
2. Click the **Intersect/Join Two Lines**  edit button. See [Reshaping Objects on page 254](#).
3. Click the left-most edge to remove the two intervening edges.
4. A message box informs you that “The system must delete intervening lines (those on the inside of the L) to join the two selected lines.” Click OK.
5. Open the Build Roof dialog and select the **Build Roof Planes** and **Use Existing Roof Baseline** check boxes to model the roof plan shown on the right side of the image above.

## Roof Baseline Specification Dialog

Like walls, each line of a Roof Baseline Polyline contains roof directives that affect automatic roof generation. Select any edge of a Roof Baseline Polyline click the **Open Object** edit button open the Roof Baseline Specification dialog.

### ROOF BASELINE PANEL

The settings on the ROOF BASELINE panel control the roof directives associated with the selected edge of the Roof Baseline Polyline. See [Selected Edge on page 212](#).

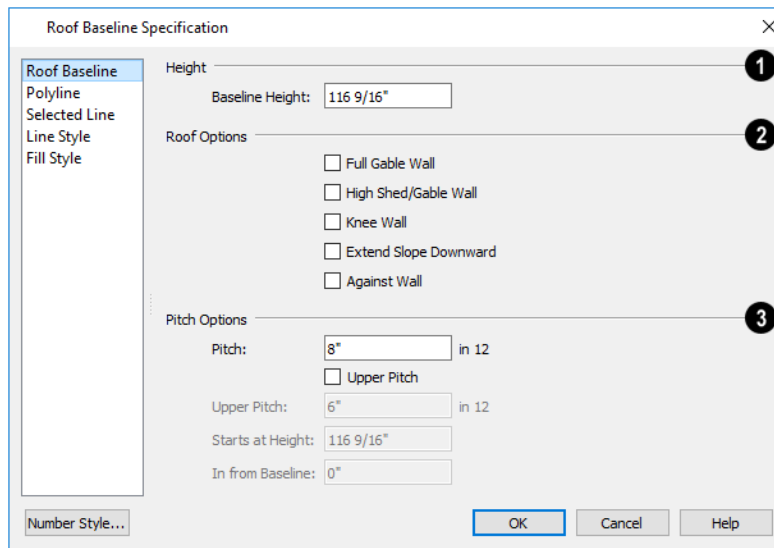

#### 1 Baseline Height

See [The Baseline on page 805](#).

#### 2 Roof Options

- The first six options: **Hip Wall**, **Full Gable Wall**, **Dutch Gable Wall**, **High Shed/Gable Wall**, **Knee Wall**, and **Extend Slope Downward** are the same as those in the Wall Specification dialog. See [Roof Panel on page 398](#).
- Select **Against Wall** if the roof plane rising from this baseline butts against an exterior wall. This is similar to checking High Shed/Gable Wall.

### **3 Pitch Options**

These settings are also found in the Wall Specification dialog. See [Roof Panel on page 398](#).

- Unlike the **Pitch** value elsewhere, this value is not a Dynamic Default here; however, you can click on the Default icon to load the current default Pitch. See [Build Roof Dialog on page 797](#).

#### **POLYLINE PANEL**

The POLYLINE panel reports general information about the size and shape of the selected Roof Baseline Polyline. See [Polyline Panel on page 818](#).

#### **SELECTED LINE PANEL**

This panel is similar to the LINE panel of the Line Specification dialog. See [Line Panel on page 304](#).

#### **LINE STYLE PANEL**

For information about the settings on this panel, see [Line Style Panel on page 305](#).

#### **FILL STYLE PANEL**

The settings on the FILL STYLE panel control the appearance of the selected Roof Baseline Polyline in plan view. See [Fill Style Panel and Dialogs on page 193](#).

---

## **Roof and Ceiling Framing**

Roof framing can be both drawn manually and generated automatically. You can also combine the two techniques. As with other kinds of framing, it is often easiest to begin by generating roof framing automatically and then editing it as needed. See [Manual vs. Automatic Framing on page 854](#).

**Roof Trusses**  cannot be generated automatically - they must be drawn manually and then replicated. If you intend to use Roof Trusses, make sure the settings in the Build Roof dialog are properly defined before you build the roof. See [Roof Trusses on page 895](#).

When using a combination of Roof Trusses and stick framing, begin by drawing the roof planes and ceiling planes. When they are in place, draw and replicate the Roof Trusses. Finally, automatically generate or manually draw the stick framing and edit it as needed. See [Mixing Rafters and Trusses on page 855](#).

Framing for manually drawn **Ceiling Planes**  cannot be drawn manually - it must be automatically generated. The framing for manually drawn Ceiling Planes is generated when roof framing is built and uses the settings in the Build Roof dialog as defaults. Once it has been created, it can be edited. See [Ceiling Planes on page 826](#).

Similarly, purlins that run perpendicular to rafters can be automatically generated in the Surface and Ceiling layers for roof and ceiling planes but cannot be drawn manually. See [Material Layers Definition Dialogs on page 1040](#).

#### **REBUILDING ROOF FRAMING**

If roof framing defaults are modified after the roof and roof framing are built, neither will update automatically. In order to update the model you need to rebuild the roof, then rebuild the roof framing.

You can also modify the roof framing settings for individual roof planes, and then either build roof framing or click the **Build Framing for Selected Object**  edit button. See [Keeping Framing Current on page 884](#).

## Curved Roof Planes

Any roof plane can be turned into a curved roof plane in the Roof Plane Specification dialog. See *Roof Plane Specification Dialog on page 814*.

One way to produce a barrel roof is using a single roof plane that starts out flat (zero pitch) and covers the entire building.

### CURVING A SINGLE ROOF PLANE

#### *To curve a roof plane*

1. Draw a simple four wall structure with a 4 in 12 pitch shed roof.

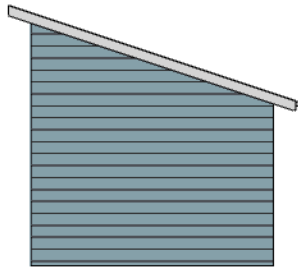

2. Select the roof plane and click the **Open Object**  edit button to open the Roof Plane Specification dialog.
3. On the GENERAL panel, change the **Pitch** to 0 in 12.

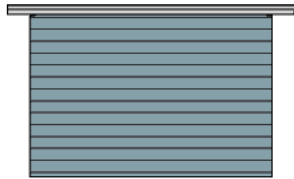

4. Check **Curved Roof** and notice that the Angle values below are both at 0.0°.
5. Change the **Angle at Eave** from 0° to 45° and press the Tab key. Notice that the other values update and that in order to maintain the 0 in 12 pitch, the **Angle at Ridge** becomes -45°.

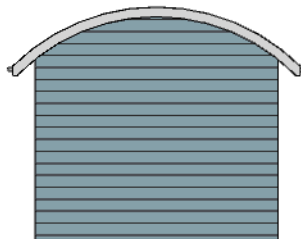

Curved Roof

Angle at Eave:

Angle at Ridge:

Radius to Roof Surface:

Facet Angle:

Automatic Facet Angle

## CURVING TWO ROOF PLANES

You can also create a barrel roof using two roof planes. A 12 in 12 pitch is used because it allows the curved roof to be nearly vertical at the eave and nearly flat at its peak.

### *To curve two roof planes*

1. Draw a simple four wall structure with a 12 in 12 pitch gable roof.

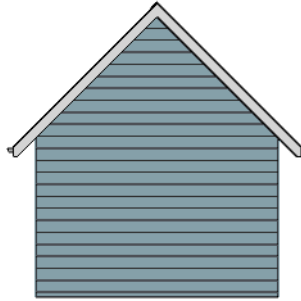

2. Select one of the roof planes and click the **Open Object**  edit button to open the Roof Plane Specification dialog.
3. Check **Curved Roof** and notice that the Angle values below are identical.
4. Change the **Angle at Ridge** from 45° to 1°. This makes the roof plane nearly flat at the ridge. The Angle At Eave updates to maintain the 12 in 12 pitch.

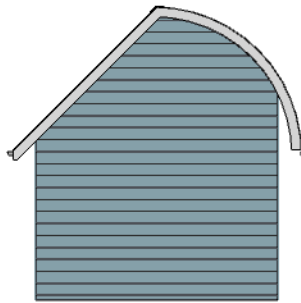

Curved Roof

Angle at Eave:

Angle at Ridge:

Radius to Roof Surface:

Facet Angle:

Automatic Facet Angle



- Repeat this process with the other roof plane.

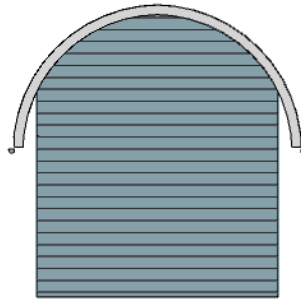

### COMPOUND CURVED ROOF PLANES

Compound curves can be created using two or more curved roof planes or a combination of straight and curved roof planes.

 Before curving roof planes or joining the edges of any curved plane, make sure all flat roof planes are correctly joined. See [Join Roof Planes on page 811](#).

#### *To create a compound curved roof*

- Draw a simple four wall structure with a 4 in 12 pitch gable roof.
- In plan view, select one of the roof planes and pull its ridge edge back so that it is 4 feet from the wall. Do the same to the other roof plane.

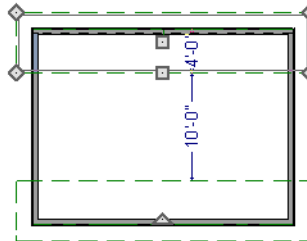

- Select both roof planes and check **Curved Roof** in the Roof Plane Specification dialog. Set the **Angle at Ridge** to 33.6901°, which is the same as 8 in 12. Notice that the **Angle at Eave** is almost flat.

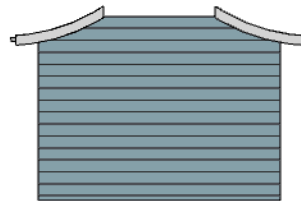

Curved Roof



Angle at Eave:

Angle at Ridge:

Radius to Roof Surface:

Facet Angle:

Automatic Facet Angle

4. Use the **Roof Plane**  tool to draw the two high roof planes. As you create each one, draw its Baseline along to the ridge edge of one of the low roof plane. See *To draw a roof plane on page 805*.
5. Select the two new roof planes, click the **Open Object**  edit button, and change their **Pitch** to 33.6901° - or 8 in 12. Viewed in 3D, the planes appear to join together into one.

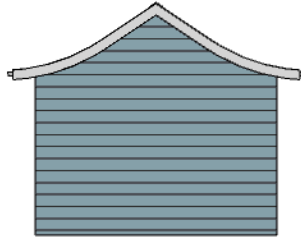

## CURVED ROOF PLANE INTERSECTIONS

Curved roof planes can be joined to other roof planes using the **Join Roof Planes**  edit tool. Often, the result is a curved roof valley or hip.

In many instances, a curved roof plane can only be joined to another roof plane if its **Angle at Ridge** or **Radius to Roof Surface** setting is changed. See *General Panel on page 814*.

When that is the case, the Join Curved Roof Plane dialog will open when the **Join Roof Planes**  tool is used.

- Choose **Lock the Radius to Roof Surface** to maintain the roof plane's curvature but change its angle at the ridge edge.
- Choose **Lock the Angle at Ridge** to maintain the roof plane's angle at its ridge edge but change its curvature.

In order to straighten a curved roof edge, select the edge in question and click the **Straighten Curved Edge**  edit button.

---

## Ceiling Planes

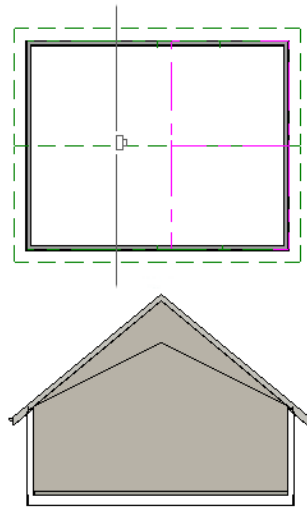

 Ceiling planes are drawn the same way as roof planes and are edited using the same tools. They are useful for creating custom vaulted ceilings. See *Vaulted and Cathedral Ceilings on page 435*.

Ceiling planes are drawn using the same default pitch as roof planes, specified in the Build Roof dialog. See *Build Roof Dialog on page 797*.



If you wish, you can specify the desired pitch in the Build Roof dialog before drawing a ceiling plane, or you can change the pitch after it is drawn in the Ceiling Plane Specification dialog. See [Ceiling Plane Specification Dialog on page 828](#).

There are a few things to remember when drawing ceiling planes.

- Ceiling planes should be created over rooms that have **Flat Ceiling Over this Room** unchecked in the Room Specification dialog. See [Structure Panel on page 439](#).
- The Baseline of a ceiling plane should be drawn along the outer surface of the bearing wall's Main Layer. This allows the ceiling plane to extend over and be supported by the wall. See [The Main Layer on page 385](#).
- The sloping edge at the side of a ceiling plane should butt to the inside of the wall.
- Ceiling planes act independent of the roof planes above.
- Usually, the pitch of a ceiling plane is lower than the pitch of the corresponding roof plane.
- Ceiling planes can be joined together using the **Join Roof Planes**  edit button. See [Join Roof Planes on page 811](#).
- Select a ceiling plane and click the **Open Object**  edit button to open the Ceiling Plane Specification dialog. See [Ceiling Plane Specification Dialog on page 828](#).

## DISPLAYING CEILING PLANES

 Ceiling planes are drawn on the “Ceiling Planes” layer by default, although you can place a ceiling plane on any layer. See [Line Style Panel on page 830](#).

Manually drawn **Ceiling Planes**  can also display labels when the “Roofs, Labels” layer is on. See [Roof Plane Labels on page 807](#).

## EDITING CEILING PLANES

Ceiling planes can be edited much like roof planes using their edit handles and edit toolbar buttons. See [Editing Roof and Ceiling Planes on page 808](#).

Ceiling planes can also be edited in their specification dialog. See [Roof Plane Specification Dialog on page 814](#).

As with roof planes, the ceiling planes layer can be locked to prevent them from being selected.

## DELETING CEILING PLANES

There are several ways to delete ceiling planes. See *Deleting Objects on page 284*.



Select **Build > Roof > Delete Ceiling Planes** to delete all ceiling planes in the current plan.



Ceiling planes can also be deleted at once in the Delete Objects dialog. See *Delete Objects Dialog on page 285*.



Select a ceiling plane or group of ceiling planes, then click the **Delete** edit button or press the Delete key.

## Ceiling Plane Specification Dialog

Select a ceiling plane and click the **Open Object** edit button to open the Ceiling Plane Specification dialog.

The Ceiling Plane Specification dialog is similar to the Roof Plane Specification dialog. See *Roof Plane Specification Dialog on page 814*.

The Ceiling Plane Specification dialog has the following panels:

### GENERAL PANEL

There are four values that define the 3D orientation of a ceiling plane: **Ridge Height**, **Height Inside Wall**, **Height Outside Wall**, and **Pitch**.

Locking any of the **Height** values defines that value as the pivot point for the selected ceiling plane. Each of these dimensions is measured from the first floor default elevation of 0' - 0".

If you lock the **Pitch** and change a Height value, the ceiling plane moves vertically, keeping the same slope. It will not pivot.

Changing these values does not affect the 2D representation of the ceiling plane.

## 1 Height/Pitch

Specify the **Height** and **Pitch** of the selected ceiling plane. Heights are measured to the bottom surface of the ceiling plane's rafters or trusses, at the center point of the ceiling plane's baseline. See [The Baseline on page 805](#).

- Select the **Elevation Reference**, which is where the Height values below are measured from.
- Define the **Ridge Height**, or lock this value to make it the ceiling plane's pivot point.
- Define the **Height Inside Wall**, or lock this value to make it the ceiling plane's pivot point. If the plane is drawn over a wall, this is located at the inside surface of the wall's Main Layer.
- Define the **Height Outside Wall**, or lock this value to make it the ceiling plane's pivot point. Only available when a ceiling plane is drawn over a wall, this is the height of the lower edge of the ceiling rafters, were they not clipped by the wall below.
- Specify the selected ceiling plane's **Pitch**, or lock this value to move the plane vertically when a Height value is changed.
- Check **Pitch in Degrees** to display the Pitch value in degrees in all dialogs as well as in roof plane labels. Values between -89° and 89° can be entered. When **Pitch in Degrees** is unchecked, Pitch is described in terms of rise and run: x inches in 12 or x mm in 1000. See [Roof Pitches in Degrees on page 849](#).

## 2 Measurements

Information about the structure of the selected ceiling plane(s) displays here for reference.

- The **Structure Thickness** is reported here for reference but is specified on the STRUCTURE panel. The default Structure Thickness is the same as that for roof planes and is set in the Build Framing dialog. See [Build Framing Dialog on page 860](#).
- The **Vertical Rafter Depth** is defined by measuring a plumb line through the ceiling structure. The greater the pitch, the greater the vertical structure depth.
- The **Top of Plate** value is the top plate height of the bearing wall, and is also the ceiling height of the room.
- **Overhang From Wall Inside** - Only appearing when a ceiling plane is drawn over a bearing wall, this is the horizontal distance from the Baseline to the inside Main Layer surface of the wall. The Baseline is typically drawn over the outside Main Layer surface, so this value is equal to the wall's Main Layer thickness.
- **Clip End** - This is the amount a ceiling rafter's underside must be clipped at its lower end to rest on the wall top plate, and is zero if the ceiling plane was not drawn over a bearing wall. This value is equal to the ceiling plane's rise in slope over the distance of the **Overhang from Inside Bottom**.

The **Outside Bottom** value plus the **Clip end** value equals the **Top of Plate** value.

## 3 Curved Ceiling

Check **Curved Ceiling** to specify the selected ceiling plane as curved. See [Curved Roof Planes on page 823](#).

- Specify the ceiling plane's **Angle at Eave**, **Angle at Ridge** and **Radius to Framing Bottom**.
- These three values are interrelated - when one is changed, the other two adjust accordingly. You may find it helpful to first specify the **Radius** value, then the **Angle** values.

A flat ceiling plane with a pitch of 0 has angles of 0 at both the ridge and eave, as well as a radius of 0.

### STRUCTURE PANEL

The settings on the STRUCTURE panel of the Ceiling Plane Specification dialog are a subset of those found on the ROOF panel of the Build Framing dialog. See [Roof Panel on page 869](#).

### POLYLINE PANEL

The POLYLINE panel states the length of the ceiling plane's **Perimeter**, its **Framing Area**, and its **Projected Area**. See [Polyline Panel on page 818](#).

### SELECTED LINE PANEL

This panel is similar to the LINE panel of the Line Specification dialog. See [Line Panel on page 304](#).

### LINE STYLE PANEL

For information about the settings on this panel, see [Line Style Panel on page 305](#).

### FILL STYLE PANEL

The settings on the FILL STYLE panel affect the appearance of the selected ceiling plane in plan view. For information about these settings, see [Fill Style Panel and Dialogs on page 193](#).

### MATERIALS PANEL

For more information about the settings on this panel, see [Materials Panel on page 1055](#).

### LABEL PANEL

Ceiling plane labels display when the "Roofs, Labels" layer is turned on and use the Text Style assigned to that layer. The Automatic Label for ceiling planes is blank, but you can specify a custom label. See [Roof Plane Labels on page 807](#).

For information about the settings on this panel, see [Label Panel on page 700](#).

### COMPONENTS PANEL

The information on the COMPONENTS panel can be used in the materials list. See [Components Panel on page 1330](#).

---

## Gable/Roof Lines



The **Gable/Roof Line** tool can be used to automatically generate a gable above the bearing wall of a hip roof plane. It is best used in situations where roof directives in walls are not possible. For example:

- Where a wall is not present, such as across the front of an alcove;
- Over a Bay, Box, or Bow Window.

See [Roof Directives in Walls on page 378](#).





In addition, the **Gable Over Door/Window** edit button allows you to add a small Gable/Roof Line over one or more selected doors or windows the next time automatic roof planes are built.

Gable/Roof Lines display in plan view when the “Roofs, Gable Lines” layer is set to display and can be selected and edited much like regular CAD lines. See [Editing Line-Based Objects on page 216](#).

## CREATING A GABLE

### *To create a gable using a Gable/Roof Line*

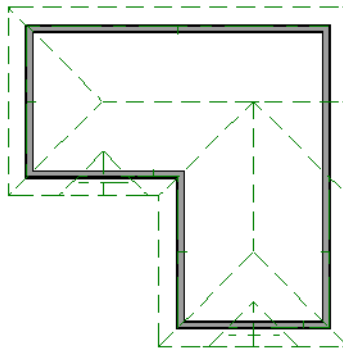

1. Select **Build> Roof> Gable/Roof Line** , then click and drag to draw a line outside the exterior wall that you want to create a gable over.
2. Position the Gable/Roof Line within 10 feet (2260 mm) of the wall’s Main Layer but not touching it. See [The Main Layer on page 385](#).
  - Make sure that the Gable/Roof Line is exactly parallel to the exterior wall.
3. Resize the Gable/Roof Line so that it is the length of the desired gable.
  - The length of the Gable/Roof Line determines the gable width at the wall Main Layer, not at the overhang.
  - At the larger roof eave, a gable roof is wider than the gable line by twice the overhang distance.
4. You can specify the pitch of the gable roof planes and their overhang in the Gable Line Specification dialog. See [Gable Line Specification Dialog on page 833](#).
5. Select **Build> Roof> Build Roof**  and regenerate the roof. See [Build Roof Dialog on page 797](#).

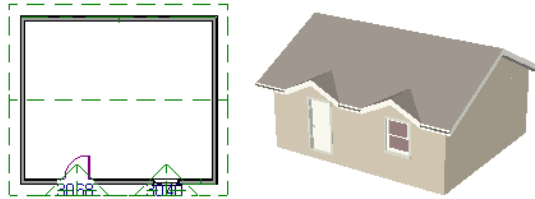

### *To use the Gable Over Door/Window tool*

1. Select one or more doors or windows.
2. Click the **Gable Over Door/Window**  edit button.
  - **Gable Over Door/Window** is not available for openings placed in Full Gable Walls or for Bay, Box or Bow Windows. See [Bay, Box, Bow Windows and Roofs on page 610](#).
3. In the Gable Line Specification dialog, specify the desired Pitch and Overhang for the gable roof. See [Gable Line Specification Dialog on page 833](#).
4. The next time automatic roof planes are built, gables will be created over each of these doors and windows.



- Each gable will extend 12” (300 mm) on either side of its door or window.
  - If two of these openings are within 30” (750 mm) of each other on the same wall, a single gable will be created.
  - If you move or resize the door or window(s), the associated Gable/Roof Line will not update until the roof is built again.
5. There are several ways to remove a Gable Over Door/Window:
- Select the door(s) or window(s) and click the **Delete Gable Over Opening**  edit button.
  - Select the gable line and click the **Delete**  edit button.
  - All Gable/Roof Lines can be deleted using the Reset to Defaults dialog. See [Reset to Defaults on page 91](#).
  - The next time the roof is built, the gable or gables will be removed.

### COVERING AN ALCOVE

A **Gable/Roof Line**  can also be used to maintain a roof plane baseline where there is no wall below. For example, you can use it to extend a roof plane across an alcove, rather than wrap into it.

In order for a **Gable/Roof Line** to direct the roof to extend over an alcove or other area where no wall is present, it must be aligned with the exterior walls' Main Layer.

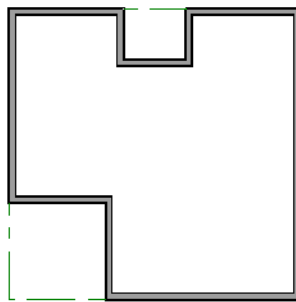

### COVERING A BAY

A **Gable/Roof Line**  drawn across a bay causes a gable to be built above the bay when roofs are automatically generated.



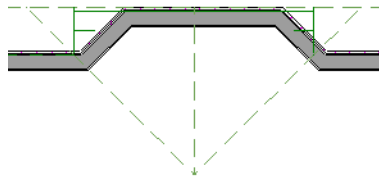

In order for the gable to be built, at least one end of the Gable/Roof Line must extend past the side walls of the bay.

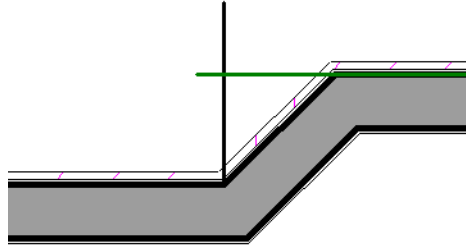

If the Gable/Roof Line is drawn along the outer edge of the bay's outer wall's Main Layer, the resulting gable will extend only to the eave of the larger roof. Draw the Gable/Roof Line beyond the bay's outer wall to extend out past the larger roof's eave.

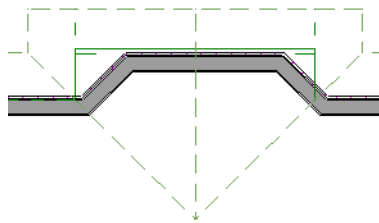

## Gable Line Specification Dialog

Select a gable line and click the **Open Object** edit button to open the Gable Line Specification dialog. This dialog also opens whenever the **Gable Over Door/Window**  edit button is clicked. See [Gable/Roof Lines on page 830](#).

### GABLE LINE PANEL

The settings on this panel affect the structure of the two roof planes associated with the selected Gable/Roof Line.

The defaults for these settings are set in the Build Roof dialog. See [Roof Panel on page 798](#).

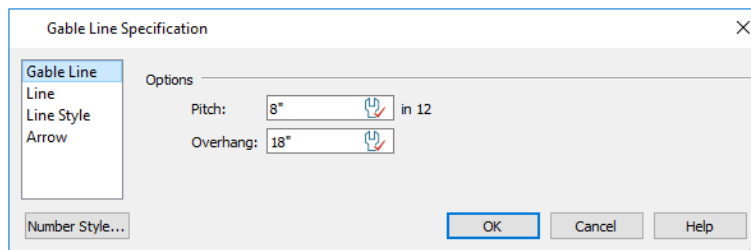

- Specify the **Pitch** of the roof planes that form the gable.
- Specify the **Overhang** of the roof planes that form the gable.

## LINE PANEL

The settings on the LINE panel are available for a variety of other objects in the program. See [Line Panel on page 304](#).

## LINE STYLE PANEL

The settings on the LINE STYLE panel are available for a variety of other objects in the program. See [Line Style Panel on page 305](#).

## ARROW PANEL

The settings on the ARROW panel are available for a variety of other objects in the program. See [Arrowheads on page 327](#).

---

# Skylights and Roof Holes



Select **Build> Roof> Skylight** to insert a flat panel skylight with a frame into a single roof plane, create a hole in the roof and the ceiling below, and also a shaft between the roof and ceiling holes.



Select **Build> Roof> Roof Hole** to create a hole in the roof and the ceiling below as well as a shaft between the two holes.

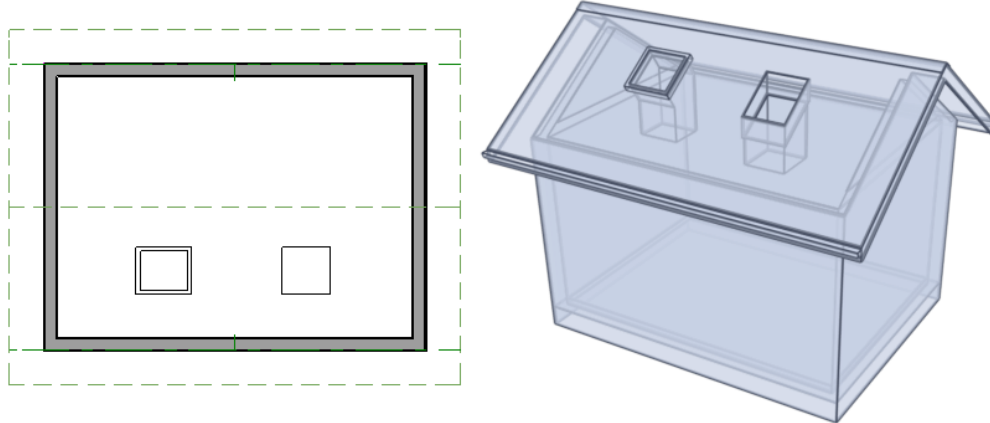

A skylight and roof hole in plan view and Glass House rendering.



A hole can also be created in a selected roof plane using the **Create Hole** edit tool. This edit tool produces a hole in the roof plane only: no shaft is generated and the ceiling below is unaffected. See [Polyline Holes on page 232](#).

## CREATING SKYLIGHTS AND ROOF HOLES

To create a Skylight or a Roof Hole, select either tool and then click and drag to draw a rectangular polyline within a single roof plane. With either tool active, you can also click once within a roof plane to place an object measuring 2' x 2', as measured in plan view with the roof pitch not taken into account.

To place a skylight in a vaulted ceiling, uncheck **Flat Ceiling Over This Room** in the Room Specification dialog, draw the Ceiling Planes to produce the vault and edit them as needed, and then draw the skylight. See [Structure Panel on page 439](#).

Note: If a sloped ceiling plane is present under the skylight, a hole in this ceiling plane is automatically produced. This hole is visible, and may be located directly under the roof hole. It can be moved and edited separately.

## DISPLAYING SKYLIGHTS AND ROOF HOLES

Skylights and roof holes are placed on the "Roofs, Openings" layer by default. See *Displaying Objects on page 176*.

Although inserted into roof planes, skylights and roof holes are able to display in plan view when their containing roofs do not. Skylights are also able to display independent of their containing roofs in 3D views.

By default, a skylight's flat ceiling hole does not display separately; however, it can be set to do so in plan view. It can then be edited separately, and even deleted entirely. See *Skylight/Roof Hole Specification Dialog on page 835*.

In plan view, the true size and shape of skylights and roof holes is only represented when they are inserted into a roof plane with a pitch of 0. The steeper the pitch of the roof, the more affected a skylight or roof hole's appearance in plan view may be affected by it. To create a skylight of a particular size, therefore, its size must be set in its specification dialog or using the **Edit Skylight Shape**  tool. See *Edit Skylight Shape on page 835*, below.

Both skylights and roof holes can display labels in plan and cross section/elevation views when the "Roofs, Labels" layer is turned on. Automatic skylight and roof hole labels report the object's size using the same format that window labels use. See *Window Labels on page 587*.

## EDITING SKYLIGHTS AND ROOF HOLES

Skylights can be selected individually or in groups and moved using their edit handle, and edited using the edit toolbar buttons and the Skylight/Roof Hole Specification dialog. See *Skylight/Roof Hole Specification Dialog on page 835*.

Skylights must always be contained by a single roof plane. If the roof plane is deleted, any skylights or holes it contains are also deleted.

### EDIT SKYLIGHT SHAPE



The **Edit Skylight Shape** edit tool lets you make changes to a selected skylight's actual shape. Not available when skylights are group-selected.

When you click this edit button, a Skylight Detail Window opens, showing the shape of the skylight's hole represented by a closed CAD polyline. This polyline can be edited to produce the desired shape, or it can be deleted and replaced with a new closed polyline created using a selection of CAD drawing tools. Only one CAD object can be present in a Skylight Detail Window, and only a closed polyline shape can be saved as a Skylight Detail. When you close this view window, the program will give you an opportunity to save your changes and apply them to the selected skylight. You can also select **Tools> Active View> Save Active View** . See *Editing Closed Polyline-Based Objects on page 228* and *Special CAD Details on page 337*.

---

## Skylight/Roof Hole Specification Dialog



Select a skylight or a roof hole and click the **Open Object** edit button to open the Skylight/Roof Hole Specification dialogs. See *Skylights and Roof Holes on page 834*.

## GENERAL PANEL

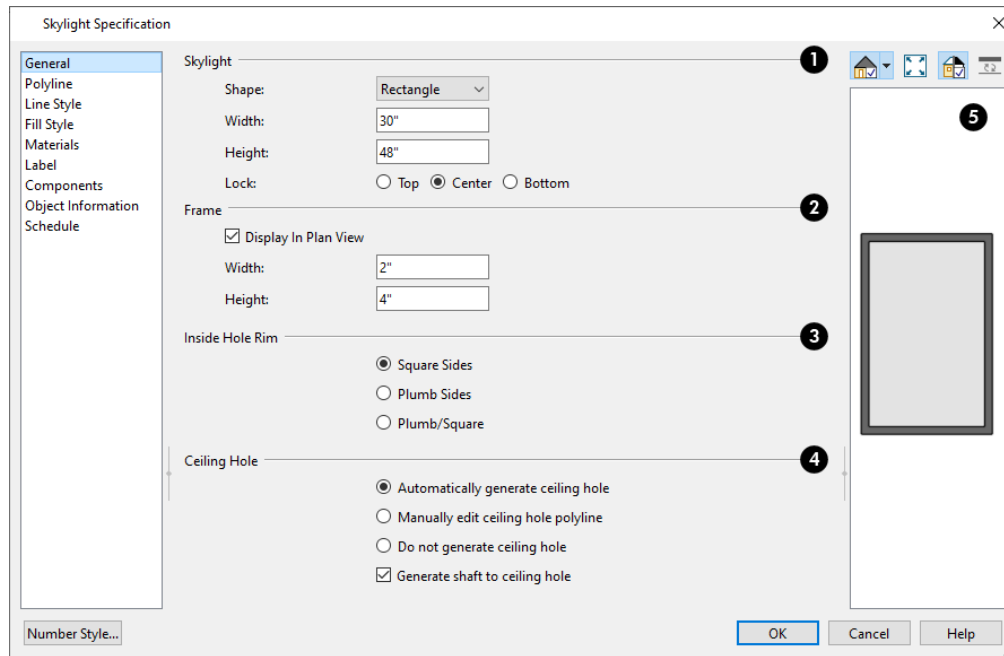

### 1 Skylight

Not available when a roof hole is selected.

- Select a **Shape** from the drop-down list: "Circle", "Ellipse", "Oval", or "Rectangle". If the Skylight's shape has been edited using the **Edit Skylight Shape** edit tool, "Custom" will be the selected Shape. See [Edit Skylight Shape on page 835](#).
- Specify the **Width** and **Height** of the selected Ellipse, Oval, or Rectangle-shaped skylight. These values describe the skylight's projected size, as measured in plan view: roof pitch is not taken into account.
- When the selected skylight is a Circle, specify its **Diameter**.
- Select which part of the skylight to **Lock** when it is resized: its **Top**, **Center**, or **Bottom**.

### 2 Frame

Not available when a roof hole is selected.

- Check **Display in Plan View** to draw the selected skylight's frame in plan view.
- Specify the **Width** and **Height** of the skylight's Frame.

### 3 Inside Hole Rim

Specify how the hole for the skylight is framed as well as the shape of the skylight well where it passes through the roof plane.

- Select **Square Sides** to cut the framing for the skylight square to the pitch of the roof.
- Select **Plumb Sides** to produce framing for the skylight that is plumb-cut.
- Select **Plumb/Square** to produce framing with the bottom edge plumb-cut and the top edge, square-cut.

#### 4 Ceiling Hole

Control how the hole in a room's Flat Ceiling is created below the skylight or roof hole. These options do not affect the hole in a manually drawn Ceiling Plane. See *Structure Panel on page 439*.

- Select **Automatically generate ceiling hole** to automatically generate and maintain the skylight's ceiling hole.

Note: The hole produced in a sloping ceiling plane by a skylight must be always manually maintained if the skylight is moved or resized.

- Select **Manually edit ceiling hole polyline** to display the editable ceiling hole polyline in plan view in addition to the polyline in the roof plane.
- Select **Do not generate ceiling hole** to generate a hole through the roof plane but not the flat ceiling.
- Uncheck **Generate shaft to ceiling hole** to generate a roof hole and a hole in the flat ceiling, but no vertical surfaces connecting them. When checked, a shaft between the two is produced. Not available if Do not generate ceiling hole is selected, above.

#### 5 Preview

A preview of the selected skylight displays here. Not available when a roof hole is selected. See *Dialog Preview Panes on page 22*.

#### POLYLINE PANEL

The POLYLINE panel states the roof hole/skylight's **Perimeter**, its **Framing Area**, and its **Projected Area**. See *Polyline Panel on page 818*.

#### SELECTED LINE PANEL

This panel is similar to the LINE panel of the Line Specification dialog. See *Line Panel on page 304*.

#### LINE STYLE PANEL

For information about the settings on this panel, see *Line Style Panel on page 305*.

#### FILL STYLE PANEL

The settings on the FILL STYLE panel control the appearance of the selected roof hole or skylight in plan view. See *Fill Style Panel and Dialogs on page 193*.

#### MATERIALS PANEL

For information about the MATERIALS panel, see *Materials Panel on page 1055*.

#### LABEL PANEL

Roof hole and skylight labels display when the "Roofs, Labels" layer is turned on and use the Text Style assigned to that layer. The Automatic Label for these objects is blank, but you can specify a custom label. See *Roof Plane Labels on page 807*.

For information about the settings on this panel, see *Label Panel on page 700*.

## COMPONENTS PANEL

The information on the COMPONENTS panel can be used in the materials list. See [Components Panel on page 1330](#).

## OBJECT INFORMATION PANEL

The information entered on the OBJECT INFORMATION panel can be used in schedules and the materials list. See [Object Information Panel on page 1331](#).

## SCHEDULE PANEL

The information on the SCHEDULE panel determine which schedule categories the selected skylight is included in. See [Schedule Panel on page 704](#).

---

# Dormers and Crickets



Dormers can be drawn manually or placed automatically using the **Auto Dormer** tools. Automatic Dormers can be placed only under certain conditions:

- Automatic Dormers can only be placed entirely within a single roof plane. They cannot extend past the eaves or ridge of this roof plane.
- Automatic Dormer side walls cannot be positioned above other walls in the plan.

If you click within a roof plane to place an automatic dormer, but click too close to an eave or the ridge, a dormer will not be created; however, its outline will. Move this outline box to a location that meets the dormer's requirements and it will be created.

Automatic dormers reside by default on their own layer, "Roofs, Dormers" by default. The display of automatic dormer components is not controlled by this layer; however, you can lock this layer to prevent unintended editing. See [Layer Display Options Dialog on page 179](#).

The initial width, height, roof style and other settings of Auto Dormers are set in the Dormer Defaults dialog. See [Dormer Defaults on page 793](#).

## AUTO FLOATING DORMER



Select **Build> Roof> Auto Floating Dormer** and click the roof plane where you would like to place the center of the dormer's front wall.

The bottom edges of all floating dormer walls are cut off by the underlying roof plane. To produce such a dormer manually, check **Roof Cuts Wall at Bottom** for the dormer walls on the ROOF panel of the Wall Specification dialog.

Usually, no room is defined by the walls of this type of dormer.

The images below show both the outside and inside of a typical floating dormer.

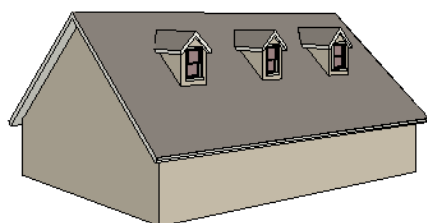

A floating dormer can be placed in plan view on the same floor that its underlying roof plane displays on, or it can be placed on the floor above. Normally, it does not matter what floor the dormer is on; but in some cases, it may need to be on the floor above so that the dormer walls do not interfere with walls or railings in the room below.

Regardless of which floor it is placed on, a dormer must always fit within a single roof plane. When placing a dormer on the floor above, you may find it helpful to turn on the **Reference Display** . See *The Reference Display on page 738*.

You may also find it helpful to display the underlying roof plane on the floor above using the Roof Plane Specification dialog. See *Roof Plane Specification Dialog on page 814*.

If the dormer is placed on the same floor as the underlying roof plane and the room below, and if the room has a flat ceiling, then a hole will be produced in the ceiling under the dormer.

## AUTO DORMER



Select **Build> Roof> Auto Dormer** and click on a roof plane where you want the center of the dormer's front wall to be.

The walls of an auto dormer go to the floor and meet a knee wall on either side on the back of the dormer. This knee wall must run parallel to the underlying roof plane's Baseline.

- If you are creating a (non-floating) auto dormer, a knee wall must already exist. The dormer side walls run back to the knee wall and the knee wall is broken where the dormer walls meet it.
- The knee wall does not have to be designated as such in the Wall Specification dialog unless you are generating an automatic roof. See *Knee Walls on page 380*.
- A non-floating dormer must always be created on the same floor as the knee walls.

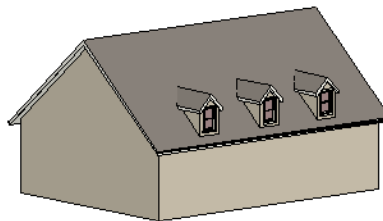
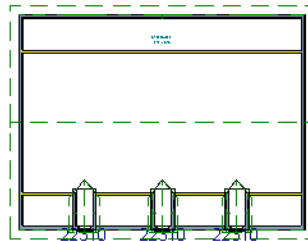

## MANUALLY DRAWN DORMERS



Once you are familiar with Chief Architect's roof tools, drawing dormers manually can be quite simple. There are several different ways to draw dormers; some methods work better in certain applications.

A variety of resources with information about drawing dormers manually is available at [chiefarchitect.com](http://chiefarchitect.com).

There are a few things to keep in mind.

- Walls extend upward until they meet an overlying roof plane.
- A wall can also be cut by underlying roof planes if **Roof Cuts Wall at Bottom** is checked in the Wall Specification dialog. For this to work properly, the edge of the roof plane must extend completely through the width of the wall. See *Clerestory and Dormer Walls on page 379*.
- Polyline can be converted into a **Hole in Roof/Ceiling** that allows walls to extend above or below the roof line. See *Convert Polyline on page 262*.

## CRICKETS

When a room's ceiling height is such that it extends above the roof of surrounding rooms, the automatic roof generator will create a cricket against any walls that face up-slope of an adjacent roof. You can also manually draw a cricket using the **Roof Plane**  tool and the **Place Roof Plane Intersection Point**  edit tool. See *Connecting Roof and Ceiling Planes on page 811*.

---

## Editing Auto Dormers

Auto Dormers are a collection of objects that behave as one. When a dormer is selected, it can be edited using its edit handles, edit tools, and specification dialog. See *Dormer Specification Dialog on page 841*.

If you click the **Explode Dormer**  edit button, the dormer's individual components can be edited.

### USING THE EDIT HANDLES

When selected, an auto dormer displays three edit handles. The Move handle displays over the front wall and allows you to relocate the dormer. Two resize handles display on the side walls and allow you to change the width of the dormer.

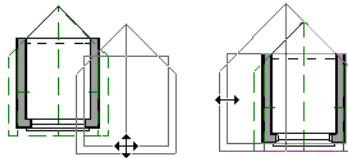

There are some things to keep in mind when editing auto dormers and auto floating dormers using the mouse.

- Dormers move at 90° angles unless the Ctrl key is pressed before moving them.
- The dormer must be contained within one underlying roof plane.
- Auto dormers cannot be moved beyond the required knee wall.

### EDITING THE WINDOW

Dormer windows can be selected, edited, deleted and replaced just like other windows. See *Editing Windows on page 588*. You can place several windows in the front wall.

Unless the dormer's window has been edited or changed in the Window Specification dialog, when the dormer width is changed, its width changes automatically to fill the front dormer wall. If the window has been edited, its width stays fixed. If a change to the dormer makes its front wall too short to hold the window, the window reverts to auto width.



## EXPLODE AUTO DORMER



Click the **Explode Auto Dormer** edit button to explode a selected auto dormer into its component parts. The dormer walls, roof planes, window, and hole in the roof/ceiling can be edited individually.

The program treats roof planes over an exploded auto dormer as though they were manually drawn, allowing you to protect them from being rebuilt in the Build Roof dialog. See [Roof Panel on page 798](#).

Once exploded, it is not possible to block the components into a Dormer object again.

## Dormer Specification Dialog



Select a dormer or dormers and click the **Open Object** edit button to open the Dormer Specification dialog.

The settings in this dialog are also found in the Dormer Defaults dialog, where they apply to all dormers as they are created rather than to a selected dormer.

## ROOF PANEL

The screenshot shows the 'Dormer Specification' dialog box with the following settings and callouts:

- 1** Roof Style: Type: Gable
- 2** Pitch: Pitch: 12" in 12; Pitch in Degrees: ; Second Pitch: 4"; In from Eave: 6"
- 3** Roof Overhang: Eave: 6"; Gable: 6"
- 4** Framing: Framing Method:  Trusses  Rafters; Fascia Depth: 5 1/2"; Eave Fascia Depth: 5 1/2"; Rafter Depth: 5 1/2"; Vertical Rafter Depth: 7 3/4"; Include:  Boxed Eaves  Gutter  Frieze  Shadow Boards; Rafter Cut:  Plumb  Square
- 5** Auto Roof Return: ; Length: 12"; Extend: 0"; Roof Type:  Gable  Hip  Full; Slope:  Sloping  Flat; Include:  Frieze  Shadow Boards  Ridge Caps

Buttons at the bottom: Number Style..., OK, Cancel, Help.

## 1 Roof Style

- Choose a roof **Type** from the drop-down list. You can choose from Hip, Gable, Shed, Gambrel, Mansard, Barrel, Curved Eave, Hip Curved Eave or Eyebrow.

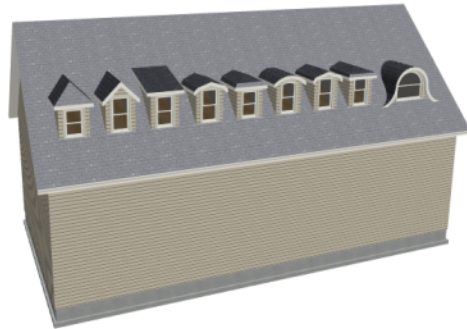

## 2 Pitch

- Specify the **Pitch** of the dormer roof planes. The default dormer pitch applies to all dormer roof types except Shed, which has a default 3 in 12 pitch. For Gambrel and Mansard types, this applies to the lowest, or eave, roof planes.
- Check **Pitch in Degrees** to display the Pitch value in degrees in all dialogs as well as in roof plane labels; uncheck it to display the pitch in terms of rise and run. See [Roof Pitches in Degrees on page 849](#).
- The **Second Pitch** specifies the upper roof of a Gambrel, Mansard, curved eave, and hip curved eave.
- When a Second Pitch is used, specify the **In from Eave** distance, measured from the lower roof plane eave to where the upper roof plane starts.

## 3 Roof Overhang

Specify the depth of the selected dormer's **Eave** and **Gable Overhangs**.

## 4 Framing

- Select the dormer roof's **Framing Method**: either **Trusses** or **Rafters**.
- Specify the **Fascia Depth** for gable fascia and the **Eave Fascia Depth**.
- Specify the **Rafter Depth**.
- The **Vertical Rafter Depth** is reported here for reference.
- Specify whether to **Include Boxed Eaves, Gutters, Frieze, and/or Shadow Boards**.
- Select either **Plumb** or **Square Rafter Cut**.

## 5 Auto Roof Return

See [Roof Returns on page 844](#).

- Check **Auto Roof Returns** to generate roof returns on the selected dormer. Roof Returns can be only specified for Gable dormers.
- Specify the horizontal **Length** of the roof return in inches (mm).
- Enter a value in inches (mm) to **Extend** the roof returns past the dormer overhang.

- Specify a **Gable**, **Hip**, or **Full** roof return.
- Specify a **Sloping** or **Flat** roof return.
- Check the boxes to **Include Shadow Boards**, **Ridge Caps**, and/or **Frieze** molding on the roof returns.

## WALLS PANEL

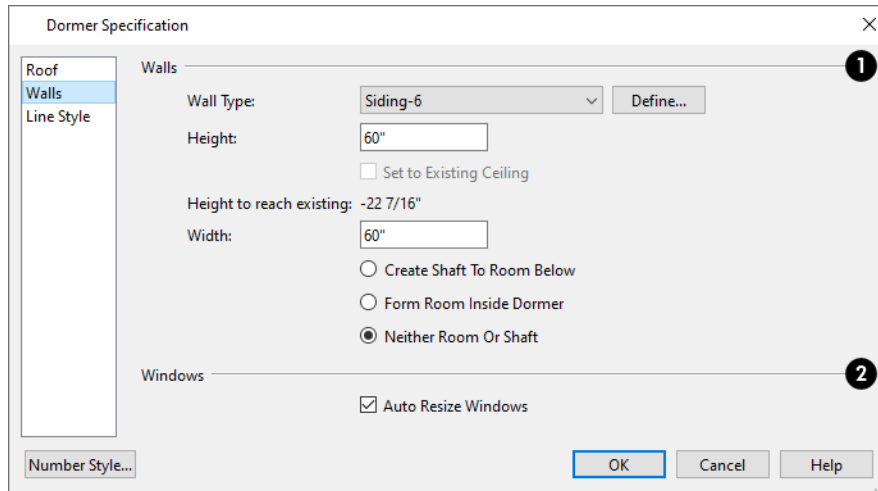

### 1 Walls

- Select a **Wall Type** for the dormer walls from the drop-down list.
- Click the **Define** button to open the Wall Type Definitions dialog to create or modify existing wall types. See [Wall Type Definitions Dialog on page 387](#).
- Specify the **Height** of the dormer, as measured from where the top of the underlying roof plane meets the dormer front wall exterior to the top plate of the dormer roof's bearing walls. This top height is called the dormer ceiling height, even if the ceiling in the dormer is not flat. The top dormer window casing is usually close to this height.
- Check **Set to Existing Ceiling** to assign the ceiling height of the room behind the dormer to the dormer. Not available in the Dormer Defaults dialog.
- **Height to Reach Existing** shows the difference between the dormer height where the inside of the wall meets the underside of the roof and the ceiling of the room behind it.
- Specify the dormer's **Width**, measured from the outside surfaces of the dormer side walls.
- The Dormer Room options are only available for Floating Dormers and are intended for use with dormers on an upper floor level:
  - Select **Create Shaft to Room Below** to create an opening in the floor platform to the floor below, and enclose the inside of the dormer with walls that form a room.
  - Select **Form Room Inside Dormer** to create an opening in the floor platform below that is defined as a room using the dormer walls plus an invisible Room Divider.
  - Select **Neither Room nor Shaft** to make no changes to the structure below the dormer.

- Dormer windows can appear too narrow on the outside due to the space required for interior casing to clear the inside surfaces of the side walls. Two additional settings are available in the Dormer Defaults dialog to help address this.
- When **Set Inside Window Trim Width** is checked, you can set the **Inside Window Trim** value, which is the default interior casing width for dormer windows. When unchecked, dormer windows use the default interior casing width set in the Window Defaults dialog.

## 2 Windows

- When **Auto Resize Windows** is checked, the selected dormer's window will resize when the dormer's height or width are adjusted. Uncheck this box to keep the window the same when the dormer is resized.

### LINE STYLE PANEL

For information about the settings on this panel, see [Line Style Panel on page 305](#).

---

## Roof Returns and Other Details

Chief Architect offers a selection of tools to add architectural details to your roof design.

### ROOF RETURNS

A roof return is a small decorative roof plane that connects to the low side of a gable roof overhang and extends below the upper triangular portion of the gable wall. Three styles of roof returns that can be produced automatically.

The first two styles are called **Gable** and **Hip** returns since the return ends in a gable or hip.

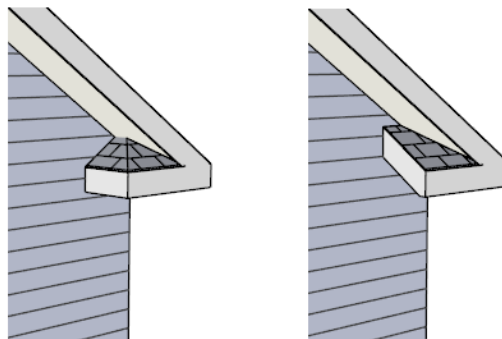

Hip and Gable Roof Returns

The third is called a **Full** return because it extends under the entire gable to connect both sides and is sometimes referred to as a water table. In order for a Full return to be created, the roof planes on each side must have the same Fascia Top Height.



Full Roof Return

It is not difficult to manually draw roof returns using small roof planes, but it is quicker to produce them automatically. Roof returns are generated automatically on a wall by wall basis using settings in the Wall Specification dialog. See [Roof Panel on page 398](#).

These roof return settings are also found in the Dormer Specification dialog for gable roof dormers and function similarly. See [Roof Panel on page 841](#).

The pitch of an automatically generated roof return is the same as that of the roof plane above it. Its structure is the same as that of the subfascia and eaves of the roof plane above. See [Structure Panel on page 817](#).

## BOXED EAVES

Boxed eaves have a flat, horizontal soffit surface instead of one that follows the underside of the rafter ends. Boxed eaves can either extend out to the gable fascia or build flush with the adjacent exterior wall.

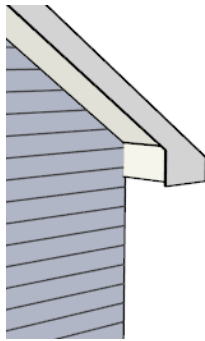

Boxed Eave at a gable end

You can specify Boxed Eaves for all roof planes in the Build Roof dialog and for individual roof planes in the Roof Plane Specification dialog. See [Options Panel on page 801](#).

The flush eave end uses the wall's surface material by default; however, you can specify a different material if you wish. See [Materials Panel on page 804](#).

## FASCIA AND SHADOW BOARDS

Fascia and shadow boards can be added to both automatic and manually drawn roof planes. They can be specified in the Build Roof dialog and added to roof planes as they are created, and they can be added to or removed from individual roof planes and roof plane edges in the Roof Plane Specification dialog.

- Fascia and eave fascia can be specified in the Build Framing and Build Roof dialogs. See [Roof Panel on page 869](#).
- One or more shadow boards profiles can be specified in the Build Roof dialog. See [Shadow Boards Panel on page 804](#).

- Fascia and shadow boards are generated whenever the roof is built or rebuilt.
- Fascia and shadow board materials can be specified separately. See [Materials Panel on page 804](#).

Fascia and shadow boards display in 3D views and are included in the materials list.

### ***Fascia***

The material specified for fascia in the Build Roof dialog displays as part of the roof plane rather than as a separate object. It displays in 3D views but not plan view.

In addition, sub fascia boards are created when roof framing is generated and are placed on the “Framing, Roof Rafters” layer. The fascia material is not applied to these framing members, however.

The width and depth of fascia and eave fascia can be specified in the Build Framing dialog. See [Roof Panel on page 869](#).

### ***Shadow Boards***

Shadow boards are added to both automatic and manually drawn roof planes when one more shadow board profile is specified in the Build Roof dialog. They can also be added to, removed from, or customized for individual roof planes in the Roof Plane Specification dialog. See [Shadow Boards Panel on page 804](#).

Automatically generated shadow boards are **3D Molding Polylines**  that follow the eaves of the roof. You can specify whether each profile is applied along eaves, along gable eaves, or along both. You can also use the same shadow board profile multiple times and adjust the offsets for each to suit different conditions. See [Molding Polylines on page 935](#).

Shadow boards are placed on the “Roofs, Trim” layer. By default, this layer is locked, turned on in 3D views but not in plan view.

If a shadow board polyline is manually edited, it will no longer be considered an Automatic shadow board, and will not be deleted and replaced when the roof is rebuilt.

You can modify individual edges of an Automatic shadow board polyline indirectly by changing settings on the SHADOW BOARDS panel of the Roof Plane Specification dialog.

Note: In order to generate shadow boards, you must also specify that fascia be used.

## **SOFFITS**

Soffits are the layer of material that covers the rafter ends on the underside of roof eaves and can be constructed in several ways:

- By default, soffits follow the underside of the rafter ends and butt against the inside edge of the fascia. The rafter end depth and thus the soffit height is controlled by the Gable Sub Fascia Depth. See [Roof Panel on page 869](#).
- Check **Flat Under Eave Sub Fascia** for soffits that follow the underside of the rafter ends until they reach the eave subfascia, at which point they flatten out until the butt against the inside of the fascia.
- Boxed eaves can be specified in the Build Roof and Roof Plane Specification dialogs. Boxed eave height is controlled by the Eave Sub Fascia Depth. See [Options Panel on page 801](#).

## **GUTTERS**

Gutters are added to non-sloping eaves on both automatic and manually drawn roof planes when a profile is specified in the Build Roof dialog. They can also be added to, removed from, or customized for individual roof planes and roof plane edges in the Roof Plane Specification dialog. If two roof planes are assigned different gutter profile or materials, however, the gutters will not merge. See [Gutter Panel on page 803](#).

Automatically generated gutters are basically **Molding Polylines**  that follow the eaves of the roof but are not created on sloped gable eaves.

- Gutters are regenerated or removed whenever the roof is built. See *Roof Panel on page 798*.
- A gutter profile can be specified. See *Gutter Panel on page 803*.
- The gutter material can be specified. See *Materials Panel on page 804*.

Gutters are placed on the “Roofs, Gutters” layer. By default, this layer is turned on in 3D views but not in plan view, is included in the materials list, and is locked. See *Layer Display Options Dialog on page 179*.

If a gutter polyline is manually edited, it will no longer be considered an Automatic gutter, and will not be deleted and replaced when the roof is rebuilt.

You can modify individual edges of an Automatic gutter polyline indirectly by changing settings on the GUTTER panel of the Roof Plane Specification dialog.

## FRIEZE MOLDING

Frieze moldings are added to both automatic and manually drawn roof planes when one or more frieze profile is specified in the Build Roof dialog. They can also be added to, removed from, or customized for individual roof planes in the Roof Plane Specification dialog.

Automatically generated frieze boards are placed along all exterior walls directly under the eaves. Frieze does not generate along railings; however, if an attic wall is built above a railing, it can generate along that wall.

- Frieze moldings are generated whenever the roof is rebuilt.
- You can specify whether each profile is applied under eaves, under gable eaves, or under both. You can also use the same profile multiple times and adjust the offsets for each to suit different conditions. See *Frieze Panel on page 804*.
- The materials used for frieze moldings can be specified. See *Materials Panel on page 804*.

Automatically generated frieze moldings are **3D Molding Polylines**  placed on the “Roofs, Trim” layer. By default, this layer is turned on in 3D views but not in plan view, and is locked. See *Locking Layers on page 178*.

If a frieze molding polyline is manually edited, it will no longer be considered an Automatic frieze, and will not be deleted and replaced when the roof is rebuilt. See *Frieze Moldings on page 943*.

## RAFTER TAILS

Rafter tails are rafter ends that overhang the bearing walls and are located under the eaves. They can be the full rafter depth or trimmed to the depth of the soffits. Rafter tails can also be partially enclosed by soffits, and sometimes feature decorative profiles.

To produce a particular type of rafter tail, set the correct defaults on the STRUCTURE panel of the Build Roof dialog before you build both the roof planes and the roof framing. See *Roof Panel on page 869*.

### *To create full-depth exposed rafter ends*

- Uncheck **Soffits**.
- Uncheck **Eave Sub Fascia**.
- Uncheck **Eave Fascia**.

### *To create hidden, trimmed rafter ends*

- Check **Trim Framing To Soffits**.
- Check **Soffits**.

### ***To create full-depth, partially-exposed rafter ends***

- Uncheck **Trim Framing To Soffits**.
- Check **Soffits**.
- Specify the desired **Gable Sub Fascia Depth**, which controls the soffit height.

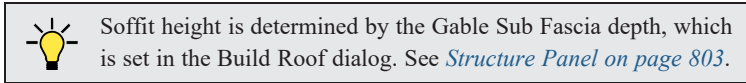

### ***To add a decorative profile to rafter tails***

- Set soffits and fascia as needed to produce the desired rafter tail exposure, as described above.
- Select a rafter tail profile on the RAFTER TAILS panel of the Build Roof dialog. See [Rafter Tails Panel on page 803](#).
- Decorative rafter tail profiles are molding profiles, which means that you can create your own custom profiles if you want. See [Molding Profiles on page 932](#).

## **RIDGE CAPS**

Ridge caps are roofing components that straddle the tops of roof ridges and hips. To generate ridge caps in Chief Architect Premier, specify one or more ridge cap profiles in the Build Roof dialog, and then build or rebuild the roof. Ridge caps will be produced on both automatically generated and manually drawn roof planes. See [Ridge Caps Panel on page 803](#).

Like shadow boards and frieze molding, automatically generated ridge caps are **3D Molding Polyline**  placed along the ridges and hips. Ridge Caps are created on the “Roofs, Ridge Caps” layer. By default, this layer is locked, displays in 3D views but does not display in plan view.

Ridge caps are essentially molding profiles, so you can apply the profile of your choice on the RIDGE CAPS panel. In most cases, a simple rectangular profile like the Default Ridge Cap works well: specify the desired Width and Height and make sure **Bend to Roof Pitch** is checked, all on the Ridge caps panel. You can also use a custom ridge cap profile if you wish. See [Molding Profiles on page 932](#).

Custom Symbol Moldings can also be used as ridge caps, but bear in mind that symbols cannot adjust their shape to match different pitches. As a result, different symbols will be required for different roof pitches. See [Symbol Moldings on page 934](#).

If a ridge cap 3D Molding Polyline is manually edited, it will no longer be considered an Automatic ridge cap, and will not be deleted and replaced if the roof is rebuilt.

You can modify individual edges of an Automatic ridge cap 3D Molding Polyline indirectly by changing settings on the RIDGE CAPS panel of the Roof Plane Specification dialog. Bear in mind, though, that your changes may only be reflected in the model if you make the same changes to adjacent roof planes, as well.



---

## Roof Pitches in Degrees

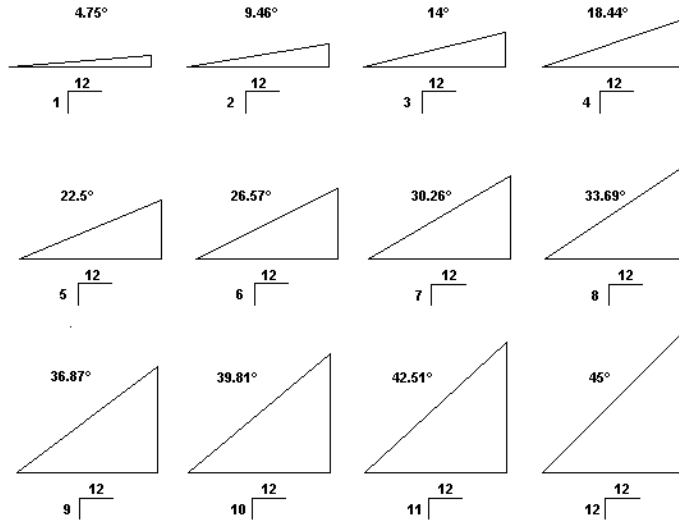

# Framing

## Chapter 24

In Chief Architect Premier, framing can be produced both manually and automatically, calculated in the Materials List, as well as listed in a schedule.

Manual framing members are drawn by clicking and dragging, like drawing a CAD line. Automatic framing for the major components of a 3D model (floors, ceilings, walls and roofs) can be generated using the Build Framing dialog.

Both manually drawn and automatically generated framing members can be selected and edited in 2D and 3D views.

Trusses are covered in their own chapter, *Trusses on page 894*.

### TOPICS

<b>Framing Defaults</b> .....	<b>851</b>
<b>Manual vs. Automatic Framing</b> .....	<b>854</b>
<b>Framing Tools</b> .....	<b>856</b>
<b>Build Framing Dialog</b> .....	<b>860</b>
<b>Framing Reference Markers</b> .....	<b>875</b>
<b>Joist Direction Lines</b> .....	<b>876</b>
<b>Joist Direction Specification Dialog</b> .....	<b>877</b>
<b>Bearing Lines</b> .....	<b>878</b>
<b>Displaying Framing</b> .....	<b>879</b>
<b>Editing Framing</b> .....	<b>882</b>
<b>Keeping Framing Current</b> .....	<b>884</b>
<b>Build Framing for Selected Object(s)</b> .....	<b>885</b>
<b>Framing and the Materials List</b> .....	<b>886</b>
<b>Framing Specification Dialog</b> .....	<b>887</b>
<b>Export to EasyFrame</b> .....	<b>890</b>

## Framing Defaults



Select **Edit > Default Settings** to open the Default Settings dialog. Select Framing from the list, then click the **Edit** button to open the Framing Defaults dialog.

Both automatic and manually-drawn framing are generated according to the settings in the Framing Defaults dialog. This dialog is nearly identical to the Build Framing dialog in both appearance and function. The only difference is that the Build Framing dialog has check boxes that allow you to generate different types of framing automatically. See [Build Framing Dialog on page 860](#).

Any changes made in the Framing Defaults or Build Framing dialog will affect subsequently drawn or generated framing, but not framing already present in the plan.



The settings in the Framing Defaults dialog directly affect a variety of important structural elements in each plan which determine floor, ceiling and roof heights; so it is best to set your Framing Defaults before building your model. See [Drawing a Plan on page 27](#).

### FLOOR AND CEILING FRAMING

Floor and ceiling platform depths contribute to the overall height of a structure, so their default values should be set as early as possible. See [Floor Panels on page 860](#).

If you plan to draw floor trusses, also see [Trusses Panel on page 872](#).

The default floor and ceiling platform settings for a given floor can be overridden on a room by room basis in the Room Specification dialog, or for individual platforms using **Joist Direction**  lines. See [Structure Panel on page 439](#).

By default, automatically-generated floor and ceiling joists run in the direction that results in the shortest span between exterior walls, bearing walls, and/or beams. **Joist Direction**  lines also allow you to define the direction that joists in a particular floor or ceiling platform. See [Joist Direction Lines on page 876](#).

Ceiling joists do not automatically generate in areas where the bottom chords of roof trusses are already present. See [Roof Trusses on page 895](#).

In standard light frame construction, floor and ceiling platforms are built to pass over or bear on the wall framing; however, this is not always desired. You can specify that joists bear on a selected wall, that platforms hang on it, or that a wall build through platforms in the Wall Specification dialog. See [Structure Panel on page 395](#).

### FRAMING GROUPS

When floor or ceiling framing is automatically generated, the program tries to create a single platform that spans as much of the structure as possible. If you need separate floor and ceiling framing in an area of your plan, as you might for an addition to an existing structure, assign the rooms in that area to a non-default Framing Group.

The program treats different Framing Groups as though they were built at different times. Wall framing builds through and divides the floor framing in different Groups, while ceiling framing butts against a ledger attached to the ceiling framing of an adjacent Group.

Framing Groups are assigned using numbers. The Default Framing Group is 1, which is built “first”. Each subsequently numbered group is framed as though it were added to the structure later.

Although Framing Groups affect how both floor and ceiling framing is generated, the **Build Framing for Selected Object** (s)  edit tool only builds floor framing. See *Build Framing for Selected Object(s) on page 885*.

## WALL FRAMING

Like other types of framing, wall framing is generated based on settings in the Framing Defaults dialog. See *Wall Panel on page 863* and *Openings Panel on page 865*.

In addition, wall framing is dependent on settings from other sources:

- Framing Type, Spacing, Width, Plate Count and size, and more can be specified for each Wall Type in the Wall Type Definitions dialog. See *Wall Type Definitions Dialog on page 387*.
- Horizontal wall framing, or Girts, can be specified for each Wall Type, as well.
- The structural specifications for individual walls can be set in the Wall Specification dialog. See *Structure Panel on page 395*.
- Stud layout can be pulled from a Framing Reference Marker or from the Start or End of each wall. See *Framing Reference Markers on page 875*.

## DOOR AND WINDOW FRAMING

The rough openings, trimmers, and sills for doors and windows and legacy fireplace objects are set in their respective defaults and specification dialogs. See:

- *Door Specification Dialog on page 558*
- *Window Specification Dialog on page 591*
- *Fireplace Specification Dialog on page 726*

Note: Door and window bucks do not automatically generate in concrete or block walls.

## HEADERS

The size, position, and composition of door and window headers can also be set in their respective defaults and specification dialogs.

In addition, a range of header depths for openings of different widths can be specified in the Framing Defaults dialog. Check **Calculate from Width** in the Door and Window Defaults dialogs to assign header depths to openings based on their width. See *Openings Panel on page 865*.

Like other framing members, headers are assigned a Structure Type such as “Lumber” or “LVL”. By default, the program will try to ensure that an opening’s Header Type agrees with the framing material used by the wall it is inserted into. To do this, it compares the Header Type to the wall’s framing material:

- Wood framing types: Lumber, I-Joist, Glulam, Engineered Lumber, LVL, PSL, and VSL.
- Steel framing types: Steel I, Steel Box, C Channel, and U Channel.

If the Header Type agrees with the wall framing material, it will be unchanged; however, if it does not agree it will change to either “Lumber” in a wood-framed wall or “C-Channel” in a steel-framed wall. To prevent this from occurring and use the specified Header Type regardless of wall material, uncheck Automatic. See *Structure Types on page 886*.

Box headers with top and bottom rails can also be specified. See *Framing Panel on page 573*.

## SILL PLATES

Sill plates are created when floor framing is generated. They are created over all exterior walls that have either Concrete or Brick material type as their Main Layer material and support a framed floor platform directly above. See *The Main Layer on page 385* and *Materials and the Materials List on page 1063*.

Sill plate size and number can be specified in the Wall Specification dialog of the supporting masonry wall. Only the bottommost plate that comes into contact with masonry is specified as **Treated**. See *Foundation Panel on page 400*.

These sill plates are placed on the “Framing, Sill Plates” layer by default. See *Displaying Framing on page 879*.

When a monolithic slab foundation is created, the bottom plates of framed walls built on the slab are specified as **Treated** and are placed on the “Framing, Wall” layer by default.

As with sill plates, multiple bottom plates can be specified in the Framing Defaults dialog, but only the bottommost plate is specified as **Treated**. See *Wall Panel on page 863*.

## POSTS AND BEAMS

The Post, Floor Beam, and Roof Beam Defaults dialogs can be accessed via the BEAMS and POSTS panels of the Framing Defaults dialog.

These defaults can also be accessed by double-clicking the respective drawing tools. In addition, the Deck Post and Deck Beam Defaults dialogs are similar, and can be accessed from the Deck Room Defaults dialog. See *Room Type Defaults on page 414*.

## ROOF FRAMING

Roofs can be framed using either rafters or trusses. You can select the **Framing Method** that you want in the Build Roof dialog. See *Build Roof Dialog on page 797*.

Settings on the ROOF and TRUSSES panels of the Framing Defaults dialog determine the structure of roof planes and manually drawn ceiling planes as well as how they rest on bearing walls, so it is important that their default values be set before building the roof. See *Roof Panel on page 869* and *Trusses Panel on page 872*.

You can add non-structural purlins to the Roof Surface Definition and/or Roof Ceiling Finish Definition. Structural purlins can be added to the Roof Structure Definition. See *Material Layers Definition Dialogs on page 1040*.

If changes are made to these defaults that you need to apply to the entire roof plan, you will need to either manually edit or rebuild the entire roof - not just the roof framing. See *Roofs on page 791*.

## DECK FRAMING

Deck rooms have special automatically generated framing and are not affected by the settings in the Framing Defaults or Build Framing dialogs. Deck framing defaults are set in the Deck Room Defaults dialog. See *Decks on page 425*.

## FRAMING TYPES AND ROLES

By default, most framing is set to use “Lumber” as the material type. You can select from a number of other types, however, such as I-Joist and Glulam. See *Structure Types on page 886*.

Each framing member also has a Role, which refers to its purpose and position in the structure. Examples include Floor Joist, Header, Plate, and Rafter. A framing member's initial Role is determined when it is created: either automatically generated or drawn manually. Once created, you can specify a different Role for any framing member in its specification dialog. See *General Panel on page 887*.

## Manual vs. Automatic Framing

Platform, roof, and wall framing can be produced manually or automatically. In most cases, automatically-generated framing is preferable because it is faster than manually placing, replicating and editing numerous individual framing members.

In many plans, though, framing is drawn using both approaches. For example, a combination of automatically generated rafters and manually drawn trusses can be used to model a roof framing plan. See [Mixing Trusses with Stick Framing on page 902](#).

Regardless of how it is created, individual framing members can be selected and edited. See [Editing Framing on page 882](#).

- [Automatic Framing on page 854](#)
- [Manual Framing on page 854](#)
- [Framing with Beams on page 856](#)
- [Mixing Manual and Automatic Framing on page 855](#)
- [Mixing Rafters and Trusses on page 855](#)

### AUTOMATIC FRAMING



Automatic framing of floor and ceiling platforms, walls and roofs can be generated using the Build Framing dialog. The settings in this dialog control the size, spacing, and type of framing drawn in a plan, and related structural information for the major components of the 3D model. See [Build Framing Dialog on page 860](#).

Automatic framing of a particular structural component is not generated until the Build Framing dialog is opened to the appropriate panel and one of two check boxes selected:

- Select the **Build** check box to build automatic framing once. For example, check **Build Wall Framing** on the WALL panel, then click OK to build wall framing once based on the current state of the model.
- Select the **Automatic** check box, then click OK to build automatic framing every time a change is made to that structural component in the plan. For example, check **Automatic Wall Framing** on the WALL panel to rebuild all wall framing any time a wall is affected by changes to the model.

Note: When Automatic framing of a particular type is enabled, framing of that type cannot be manually edited or deleted.





In order for framing to generate in a particular layer of a structural component such as a wall assembly or floor platform, that layer must have the Framing specification. See [Wall Type Definitions Dialog on page 387](#) and [Material Layers Definition Dialogs on page 1040](#).

By default, joists automatically generate in the direction that results in the shortest span; however, you can produce different results using interior walls specified as **Bearing Walls**, **Bearing Lines** , **Floor/Ceiling Beams** , and/or **Joist Direction**  lines. See [Bearing Lines on page 878](#) and [Joist Direction Lines on page 876](#).

### MANUAL FRAMING

Framing objects can also be drawn manually. With the exception of Posts, framing objects are drawn by clicking and dragging in a straight line, the way other line-based objects are. See [Line Tools on page 300](#).

The manual framing tools are organized into families: general framing, floor and ceiling framing and roof framing. The family that a drawing tool belongs to determines where it can be used:

- Roof framing objects can only be drawn within the area of one or more roof planes.
- Floor and ceiling framing objects can only be drawn within one or more floor or ceiling platforms.
- **General Framing**  objects and **Posts**  can be drawn anywhere in a model.
- **General Framing**  objects can also be drawn in CAD Details. See *CAD Details on page 337*.
- **Wall Bridging**  can only be drawn in a Wall Detail window. See *In Wall Detail Views on page 880*.

## REBUILDING AND RETAINING FRAMING

It is important to remember that framing does not update automatically when changes are made to the model unless it is set to do so. You can direct the program to rebuild the automatic framing of floors/ceilings, walls and/or roofs every time a change to the model affects one of these components. To do this, select the **Automatic** check box on the FLOOR, WALL, and/or ROOF panels of the Build Framing dialog. See *Build Framing Dialog on page 860*.

You can also rebuild the framing of a single wall, roof plane, or ceiling plane by clicking the **Build Framing for Selected Object**  edit button. The floor framing for a selected room can also be rebuilt using this tool.

To learn more, see *Keeping Framing Current on page 884*.

When automatic framing associated with a particular panel in the Build Framing dialog is generated, any existing automatically produced framing of that type is deleted and replaced. You can prevent this from happening to a selected wall, room, or roof or ceiling plane by checking **Retain Wall Framing** or **Retain Roof Framing** in the object's specification dialog. Although their framing is not generated with other ceiling framing, Tray Ceiling Polylines also have a **Retain Framing** check box in their specification dialog.

## MIXING MANUAL AND AUTOMATIC FRAMING

Floor and ceiling platforms can be framed with a combination of manually-drawn and automatically generated joists. Similarly, roof planes can be framed with a combination of manually drawn and automatic rafters.

If you plan to use this approach, bear in mind that automatically generated joists and rafters will not be created in the same location as an existing, manually drawn joist or rafter; but, they will not necessarily use the same layout. For consistent layout, consider using a **Framing Reference Marker** . See *Framing Reference Markers on page 875*.

Manually drawn floor, ceiling, and roof framing is unaffected when automatic framing is rebuilt and remains along with the newly produced automatic framing. In contrast, manually drawn wall framing is deleted when automatic framing is rebuilt. You can, however, prevent this from happening by checking **Retain Wall Framing** in the Wall Specification dialog.

## MIXING RAFTERS AND TRUSSES

- Roofs can be framed with rafters, trusses, or a combination of the two. If you plan to combine roof trusses with rafters and/or ceiling joists, you can save time by:
- Check **Trusses (No birdsmouth)** in the Build Roof dialog before automatically building or manually drawing a roof. See *Build Roof Dialog on page 797*.
- Draw and position all roof trusses before automatically generating framing to produce rafters and ceiling joists. See *Roof Trusses on page 895*.

For more information, see *Mixing Trusses with Stick Framing on page 902*.



## FRAMING WITH BEAMS

**Floor/Ceiling Beams**  can be drawn in a plan either before or after automatic framing has been generated. Default settings for beams can be set in the Framing Defaults dialog. See *Beams Panel on page 867*.





If a Floor/Ceiling Beam is present and wall framing is generated, posts will be placed under the beam in any walls that pass under it and studs and top plates will build around the beam as necessary.

If a Floor/Ceiling Beam is created before automatic floor or ceiling framing, you can specify whether joists bear on the beam or hang on its sides.

### *To build joists that bear on a beam*

1. Draw a **Floor/Ceiling Beam**  at the desired location in your plan.
2. Select the beam and click the **Open Object**  edit button. On the GENERAL panel of the Beam Specification dialog, confirm that:
  - The **Top Height** value is equal to the Ceiling Height of the room(s) over which the beam is placed.
  - **Bearing Beam** is checked.
3. Click OK, then select **Build> Framing> Build Framing**  and build the appropriate floor or ceiling framing. See *Floor Panels on page 860*.

### *To build joists that butt against a beam*



1. Draw a **Floor/Ceiling Beam**  at the desired location in your plan.
2. Select the beam and click the **Open Object**  edit button. On the GENERAL panel of the Beam Specification dialog:
  - Specify the desired **Depth** value and then lock it.
  - Specify the **Bottom Height** value so that it is equal to the Ceiling Height of the room(s) over which the beam is placed.
3. Uncheck **Bearing Beam**.
4. If necessary, select **Build> Framing> Joist Direction**  and draw a line perpendicular to the beam and within the floor or ceiling platform.
5. Click OK, then select **Build> Framing> Build Framing**  and build the appropriate floor or ceiling framing. See *Floor Panels on page 860*.

---

## Framing Tools



Select **Build> Framing** to access the automatic and manual Framing Tools.

The Framing Tools family has three separate parent buttons: **General Framing Tools** , **Floor/Ceiling Framing Tools** , and **Roof Framing Tools** .

The default settings for framing members are derived from their respective panels in the Framing Defaults dialog. See *Framing Defaults on page 851*.



Most types of framing can be created both manually and automatically. Once created, both automatically generated and manually drawn framing members can be selected and edited. See [Editing Framing on page 882](#).

 Horizontal floor/ceiling platform framing members are referred to as "joists"; vertical wall framing members are referred to as "studs"; and sloped roof framing members are referred to as "rafters".

## BUILD FRAMING



Select **Build> Framing> Build Framing** to open the Build Framing dialog. Here, you can define settings that control how framing is drawn and generate automatic framing. See [Build Framing Dialog on page 860](#).



Select **Build> Framing> Build All Framing** to build or rebuild all floor, ceiling, wall, and roof framing throughout the current plan. See [Automatic Framing on page 854](#).

## GENERAL FRAMING



General Framing objects are generic, framing members that can be drawn outside a floor or ceiling platform or roof plane. Select **Build> Framing> General Framing**, then click and drag in a straight line to create one of these objects. In plan view, a horizontal framing member is created; in a Wall Detail, vertical members can also be drawn. See [In Wall Detail Views on page 880](#).

## WALL BRIDGING



**Wall Bridging**, or blocking, can be created both automatically and manually, but can only be drawn manually in a Wall Detail. To do so, open a Wall Detail and select **Build> Framing> Wall Bridging**, then click and drag in a straight line across the wall in the view. See [In Wall Detail Views on page 880](#).

Each run of bridging has gaps where it crosses studs, but behaves as a single object.

Automatic wall bridging can be created when wall framing is built or rebuilt. See [Wall Panel on page 863](#).

## POST



Posts can only be placed manually. To do so, select **Build> Framing> Post** and click in plan view.

## POST WITH FOOTING



Posts can also be created with footings beneath them. Select **Build> Framing> Post** and click in plan view to place a post centered over a footing. Post footings are **Slab**  objects and can be selected independent of their posts. See [The Slab Tools on page 719](#).

## RAFTER



Rafters can be drawn both manually and automatically. To draw a rafter manually, select **Build> Framing> Rafter** in plan view, then click and drag in a straight line within a roof plane.

Rafters are edited like other framing members, except that you cannot set the height. If a rafter is moved, its height and slope are automatically reset to fit under the roof plane at its new position.

## ROOF BLOCKING



Roof Blocking is automatically generated in the eaves if a soffit is not present; otherwise, blocking is drawn manually. In plan view, select **Build> Framing> Roof Blocking** and click and drag in a straight line within a roof plane. Blocking is typically drawn perpendicular to the rafters, but at the same pitch.

Each run of blocking behaves as a single object but has gaps where it crosses rafters, trusses or other blocking.

Before drawing Roof Blocking:

- Specify whether you want **In Line**, **Stagger** blocking, or **Cross** bridging in the Framing Defaults dialog.
- Build the roof framing. See [Roof Panel on page 869](#).

In 3D, roof blocking is tilted to follow the pitch of the roof plane in which it is drawn.

## ROOF TRUSS



Roof trusses can only be drawn manually. To do so, select **Build> Framing> Roof Truss** in plan view and click and drag in a straight line within one or more roof planes. Roof planes and either a default or manually drawn ceiling must be present before a roof truss can be drawn. See [Roof Trusses on page 895](#).

## ROOF BEAM



Roof beams can only be drawn manually. To do so, select **Build> Framing> Roof Beam** in plan view and click and drag in a straight line. Roof beams are normally drawn across rafters and placed directly under them.

## ROOF PURLIN



Roof purlins can be both drawn manually and generated automatically. To draw a purlin, select **Build> Framing> Roof Purlin** in plan view and click and drag in a straight line. In order to create purlins, they must be drawn:

- Within a roof plane that has a Purlins layer defined in its Roof Surface Definition. See [Material Layers Definition Dialogs on page 1040](#).
- Perpendicular to the pitch of the roof plane.

## JOIST



Floor and ceiling joists can be both drawn manually and generated automatically. To draw a joist, select **Build> Framing> Joist** in plan view, then click and drag in a straight line within a floor or ceiling platform.

Joists are always drawn as the ceiling framing for the current floor. See [The Current Floor on page 737](#). Whether a floor or ceiling joist is drawn is determined by the presence of a floor platform above.

- If there is no floor platform above, a ceiling joist is drawn.
- If there is a floor platform above, a floor joist is drawn.

If you want to draw floor joists for Floor 1, for example, you must do so on Floor 0. See [Foundations on page 705](#).

Joists can be automatically generated for multiple floors in the Build Framing dialog. See [Floor Panels on page 860](#).



Ceiling joists, floor joists and rafters have their own layers. Proper layer assignment maximizes display and materials flexibility.

## JOIST BLOCKING

 Joist blocking can only be drawn manually in plan view. To do so, select **Build> Framing> Joist Blocking**, then click and drag in a straight line within a floor or ceiling platform.

Before drawing Joist Blocking:

- Specify whether you want **In Line**, **Stagger** blocking, or **Cross** bridging in the Framing Defaults dialog.
- Build the floor and/or ceiling platform. See [Floor Panels on page 860](#).

Regardless of how many joists or other objects it crosses, each run of blocking behaves as a single object.

## FLOOR/CEILING TRUSS

 Floor and ceiling trusses can only be drawn manually in plan view. Select **Build> Framing> Floor/Ceiling Truss**, then click and drag in a straight line within a floor or ceiling platform. See [Floor and Ceiling Trusses on page 895](#).

## FLOOR/CEILING BEAM

 Floor and ceiling beams can only be drawn manually in plan view. Select **Build> Framing> Floor/Ceiling Beam**, then click and drag in a straight line within a floor or ceiling platform.

Beams can be drawn in two different ways:

- **Under Joists** places the beam underneath the joists so the joists can bear on it.
- **With Joists** places the top of the beam even with the tops of the joists it supports. The joist then butts against it. See [Beams Panel on page 867](#).

## FRAMING REFERENCE MARKER

 **Framing Reference Markers** are manually-placed reference points that specify how automatically-generated framing is laid out. To place one, select **Build> Framing> Framing Reference Marker** in plan view and click to place a Framing Reference Marker.

A Framing Reference Marker can also be created by placing a **Marker**  and then specifying its type. See [Markers on page 529](#) and [Framing Reference Markers on page 875](#).

## BEARING LINE

 **Bearing Lines** direct the program to lap or butt joists and/or rafters where they cross the line instead of spanning from wall to wall, and can only be drawn in plan view. To draw one, select **Build> Framing> Bearing Line** and click and drag in a straight line. See [Bearing Lines on page 878](#).



## JOIST DIRECTION

 **Joist Direction** lines define the direction in which joists run in a floor or ceiling platform and can only be drawn in plan view. To draw one, select **Build> Framing> Joist Direction** and click and drag within a floor or ceiling platform. See [Joist Direction Lines on page 876](#).

## Build Framing Dialog



Automatic framing can be generated by selecting **Build> Framing> Build Framing** to open the Build Framing dialog. This dialog can also be accessed by double-clicking the **General Framing**  button or any of the

**Floor/Ceiling Framing Tools** , or **Roof Framing Tools**  buttons.

The settings in this dialog are similar to those found in the Framing Defaults dialog.

Each major structural component of the model has its own panel or panels in the Build Roof dialog. The number of panels in the dialog varies depending on how many floors are in your model. There will be a panel called “1st” for the first floor, “2nd” for the second floor, and so on.

- Floor and ceiling framing settings are found on the Floor panels. See [Floor Panels on page 860](#).
- Wall framing settings are located on the WALL, OPENINGS, and FIREPLACES panels. See [Wall Panel on page 863](#), [Openings Panel on page 865](#), and [Fireplaces Panel on page 866](#).
- Floor/Ceiling Beam and Roof Beam settings are found on the BEAMS panel. See [Build Framing Dialog on page 860](#).
- Post, floor/ceiling beam and roof beam settings are found on the POSTS panel. See [Posts Panel on page 868](#).
- Roof framing settings are located on the ROOF and TRUSSES panels. See [Roof Panel on page 869](#) and [Trusses Panel on page 872](#).
- The settings on the ROOF panel are the same as those on the STRUCTURE panel of the Build Roof dialog. See [Roof Panel on page 869](#).
- You can specify how framing looks in plan view on the PLAN VIEW panel. See [Plan View Panel on page 874](#).
- You can set the default materials used for framing on the MATERIALS panel. See [Materials Panel on page 875](#).



For best results, create roof framing before or at the same time that ceiling joists are generated.

### FLOOR PANELS

The default floor and ceiling framing for individual floor levels is set here. The defaults for all floor levels, however, is set in the Floor/Ceiling Platform Defaults dialog. See [Floor and Room Defaults on page 413](#).

The floor framing for a given floor level is always generated or manually drawn on the floor below. As such, the floor framing settings for a given floor level are found on the FLOOR panel for the floor below it. For example, the floor framing settings for Floor 2 are found on the 1ST panel, while the floor framing settings for Floor 1 are found on the FOUNDATION panel. See [Floor and Ceiling Platforms on page 428](#).

In order to create the floor framing for Floor 1, a Floor 0 must be present. If a Floor 0 has not been built, the **Build Floor Framing** check box on the FOUNDATION panel will not be available. See [Foundations on page 705](#).

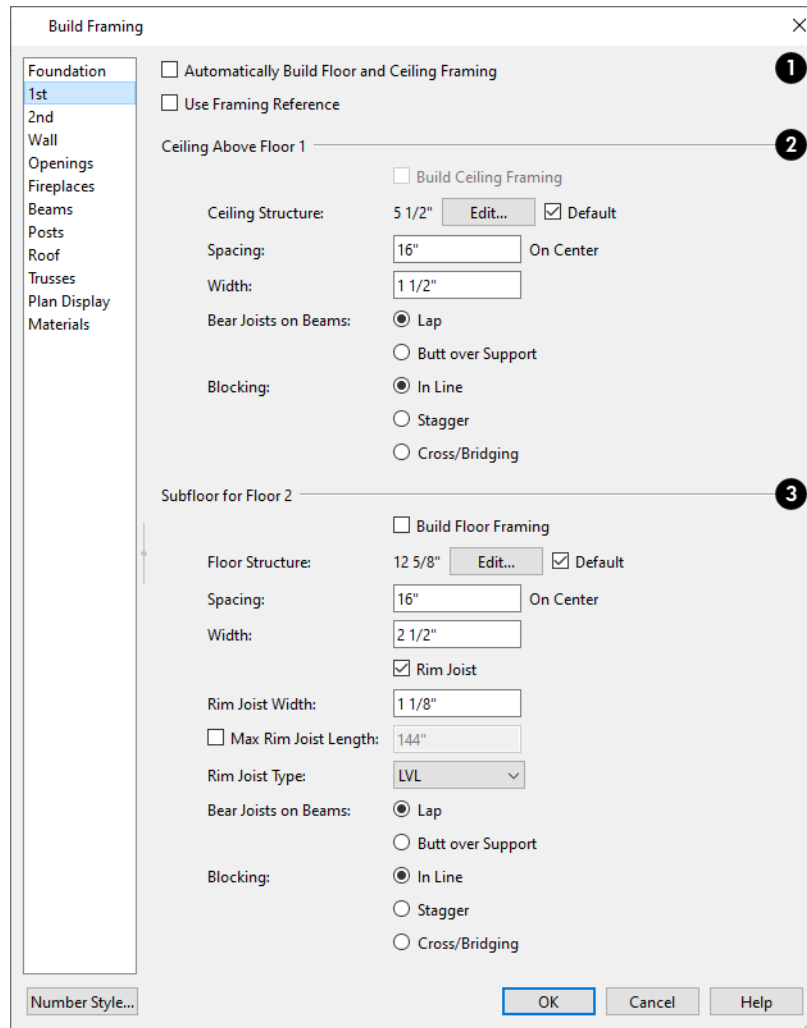

### 1 Automatic Floor/Ceiling Framing

Check **Automatic Floor/Ceiling Framing** to regenerate floor and ceiling framing whenever changes are made to the model. See [Automatic Framing on page 854](#).

- Check **Use Framing Reference** to use a Framing Reference Marker as the starting point for joist layout. If a Framing Reference Marker is present, the center of the first joist is placed at this point and spacing goes from there. If joists are lapped, the surface is placed at this point. When this is unchecked, the program tries to position ceiling joists so that they coincide with rafters. See [Framing Reference Markers on page 875](#).

### 2 Ceiling Above Floor X

Ceiling platforms are only present above rooms that do not have living space above them. Ceiling platforms that already have the bottom chords of roof trusses present in them do not receive automatically generated joists. See [Roof Trusses on page 895](#).

- Check **Build Ceiling Framing** to generate or regenerate ceiling framing when the **OK** button is clicked. Only available when there is no living space above at least part of the current floor. Not available in the Framing Defaults dialog.

- The **Ceiling Structure** depth displays here for reference. Click the **Edit** button to open the Ceiling Structure Definition dialog and define the layers of materials that form the ceiling platform. See *Material Layers Definition Dialogs on page 1040*.
- Check **Default** to use the Ceiling Structure Definition set in the Floor/Ceiling Platform Defaults dialog. See *Floor and Room Defaults on page 413*.
- Enter a value for the On Center **Spacing** of joists generated in ceiling platforms on Floor X.
- Specify the **Width**, which is the horizontal thickness of the ceiling's joists or trusses.
- Specify how the ceiling framing members **Bear on Beams** and Bearing Walls: they can either **Lap** side by side or **Butt** end to end. The lap is 8" (200 mm) and centered over the support.
- Specify what style of **Blocking** or bridging is produced for the ceiling when **Joist Blocking**  is manually drawn after joists are in place. See *Joist Blocking on page 859*.
- **In Line** produces blocking pieces that align with each other.
- **Stagger** produces blocking that alternates on either side of the line you draw.
- **Cross** produces cross bridging that looks like in line blocking in plan view, but shows as cross bridging in 3D views and the materials list.

### **3** Subfloor of Floor Y

If a room has a living space above it, its ceiling will be supplied by the floor platform of the room(s) above instead of a ceiling platform.

- Check **Build Floor Framing** to generate or regenerate floor framing when the **OK** button is clicked. Not available in the Framing Defaults dialog or if there is no floor level located below Floor Y.
- The **Floor Structure** depth displays here for reference. Click the **Edit** button to open the Floor Structure Definition dialog and define the layers of materials that form the floor platform. Only available if there is living space above at least part of the current floor.
- Check **Default** to use the Floor Structure Definition set in the Floor/Ceiling Platform Defaults dialog.
- Enter a value for the on center **Spacing** of floor joists above the current floor.
- Specify the **Width**, which is the horizontal thickness of the floor's joists or trusses.
- Check **Rim Joist** to create rim joists across the ends of the floor joists when floor framing is generated. If this is unchecked, line blocking across the ends of the floor joists is usually drawn in manually later.
- Check **Max Rim Joist Length**, then specify the maximum allowable length for rim joist boards. When unchecked, rim joists run the full length of each platform edge where joist ends are found.
- Specify the **Rim Joist Width**, which is the horizontal thickness.
- Select the **Rim Joist Type** from the drop-down list.
- Specify how the floor framing members **Bear on Beams** and Bearing Walls: they can either **Lap** side to side or **Butt** end to end. The lap is 8" (200 mm) and centered over the support.
- Specify what style of **Blocking** or bridging is produced for the floor when **Joist Blocking**  is manually drawn after joists are in place. See #2, above.

## WALL PANEL

The Thickness, Spacing, Count, and Length settings on this panel serve as the defaults for framed wall types. See *Wall Type Definitions Dialog on page 387*.

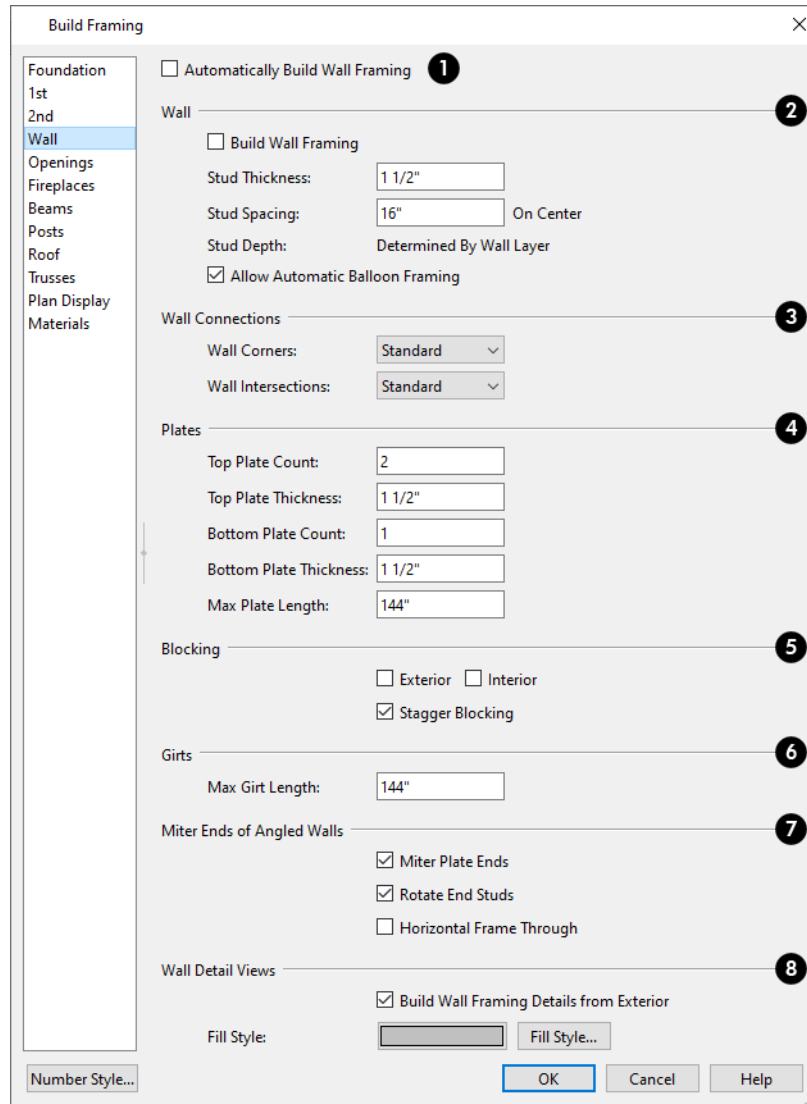

### 1 Automatically Build Wall Framing

Check this box to regenerate wall framing whenever changes are made to the model. See *Automatic Framing on page 854*.

### 2 Wall

Specify how wall studs are created.

- Check **Build Wall Framing** to build wall framing for the entire model. Framing is built in walls with one or more layers specified as Framing. Not available in the Framing Defaults dialog. See *Wall Type Definitions on page 384*.

- Specify the **Stud Thickness** for all wall Framing layers in the plan. Stud depth is equal to the thickness of each wall layer that has a Framing material.

Note: If the Stud Thickness is equal to the stud depth, only one stud will be created at wall corners.

- Specify the **Stud Spacing** for all wall Framing layers in the plan, starting from the Framing Reference Marker, if one is present. See *Framing Reference Markers on page 875*.
- **Stud Depth** - The depth of each wall stud is determined by the thickness of its wall layer, which is set in the Wall Type Definitions dialog. See *Wall Type Definitions Dialog on page 387*.
- When **Allow Automatic Balloon Framing** is checked, walls adjacent to Open Below rooms are balloon-framed. Uncheck this box to instead produce wall plates separated by rim joists instead. See *Effects of Room Functions on page 416*.

### 3 Wall Connections

Specify how the framing at **Wall Corners** and **Wall Intersections** is generated.

- Select "Standard" to produce corners or intersections composed of three studs.
- Select "Reduced Stud" to produce corners or intersections composed of two studs.
- Select "Laddered" to add horizontal ladder blocking at corners or intersections.
- Select "U Shaped" to produce corners composed of three studs in a U-shaped configuration. Only available for Wall Corners.

### 4 Plates

Define how top and bottom plates are generated.

- Specify the **Top Plate Count**, as well as their vertical **Thickness**.
- Specify the **Bottom Plate Count**, as well as their vertical **Thickness**.
- Specify the **Max Plate Length**, which is the maximum allowed length for the boards that make up the top and bottom plates. This value is only applicable for wall types that are set to use a maximum plate length.

### 5 Blocking

Specify where and how horizontal blocking is created. Each run of blocking behaves as a single object but has gaps where it crosses studs. See *Wall Bridging on page 857*.

- Check **Exterior** to automatically produce blocking on exterior walls when wall framing is built.
- Check **Interior** to automatically produce blocking on internal walls when wall framing is built.
- **In Line** produces blocking pieces that align with each other.
- **Stagger** produces blocking that alternates on either side of a center line along the wall.
- Wall blocking is generated exactly half-way up each wall's total height. Once created, it can be selected in a Framing Overview or Wall Detail.

### 6 Girts

Specify the **Max Girt Length**, which is the maximum allowed length for horizontal girt boards. This value is only applicable for wall types that are set to use a maximum girt length.



## 7 Mitre Ends of Angle Walls

Specify how wall corners that are not right angles are framed. 90° corners are not affected by these settings.

- Select **Mitre Plate Ends** to mitre the ends of the top and bottom plates. If unchecked, top and bottom plates will be butted together.
- Select **Rotate End Studs** to rotate the studs closest to mitre ends to the angle of the mitre. If unchecked, studs will remain perpendicular to the angle of the walls.
- Select **Horizontal Frame Through** to frame through the horizontal walls in plan view, butting vertical walls against them. If unchecked, walls that are vertical in plan view will frame through.

## 8 Wall Detail Views

- Check **Build Wall Framing Details from Exterior** to have Wall Detail views display from the exterior of the plan rather than the interior. See *In Wall Detail Views on page 880*.
- Specify the **Fill Style** for wall framing members in Wall Detail views by clicking the **Fill Style** button to open the Default Wall Detail Fill Style dialog. See *Displaying Framing on page 879*.

## OPENINGS PANEL

Various defaults for door and window headers as well as the trimmers for bay/box/bow windows can be set here.

The rough openings for doors and windows can be specified in the Door and Window Defaults and Specification dialogs. See *Door and Window Framing on page 852*.

Span Width Less Than	Depth
49"	5 1/2"
73"	7 1/4"
97"	9 1/4"
121"	11 1/4"

Maximum Depth: 11 7/8"

Bay/Box/Bow Window Trimmers

Maximum Number: 3

Component Thickness: 3/4"

Materials List

List Cut Header Lengths in Mixed Reporting

Plan Views

Header Fill Style:

## 1 Header Sizes

Specify default **Header Sizes**, dependent on width of the door or window, including its Rough Opening. These values should be set so that the wider the opening, the deeper the header.

- If the top of an opening's Rough Opening is closer to the top plate than the **Maximum Depth**, a solid header is produced to fill the entire space. Short cripple studs between the header and top plate are not produced.

## 2 Bay/Box/Bow Trimmers

Specify how **Bay/Box/Bow Trimmers**, are generated.

- Specify the **Maximum Number** of trimmers that a Bay, Box, or Bow Window with a lowered top height can have on each side of the opening.
- Specify the **Component Thickness**, which is the thickness of a thinner trimmer for manually resized Bay/Box/Bow Window components if a standard trimmer does not fit. See *Component Windows on page 609*.

## 3 Materials List

Check **List Cut Header Lengths in Mixed Reporting** to show precut headers in the Materials List. Precut headers are shown only if the walls have been framed and Mixed Reported is selected as the reporting method. See *Structural Member Reporting on page 1306*.

If this is unchecked, the Materials List produces a total footage for all headers. When checked, each different length of precut header is listed separately. Note that the total number of headers is affected by the **Count** value of each door and window.

## 4 Plan Views

Specify the default **Header Fill Style** for door and window headers by clicking the **Fill Style** button to open the Wall Header Fill Style dialog. See *Displaying Framing on page 879*.

## FIREPLACES PANEL

The rough openings for legacy Fireplaces placed in walls can be set on the FIREPLACES panel. See *Fireplaces on page 724*.

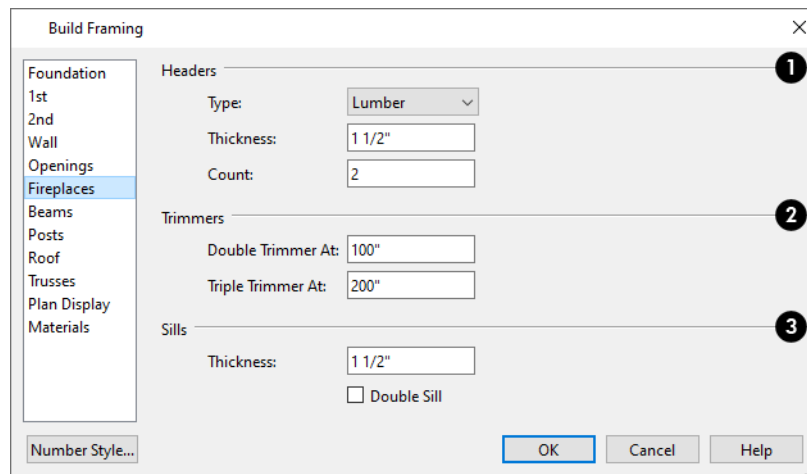

## 1 Headers

Specify the characteristics of fireplace **Headers**.

- Specify the **Type** of material used for fireplace headers.
- Specify the **Thickness** of fireplace headers.
- Specify the **Count** of boards used to form a fireplace header.

## 2 Trimmers

Specify when to generate multiple **Trimmers** on each side of a fireplace. These values include the fireplace's Rough Opening. See *Door and Window Framing on page 852*.

- **Double Trimmer At** - Fireplace openings of this width or greater receive two trimmers on each side when framed.
- **Triple Trimmer At** - Fireplace openings of this width or greater receive three trimmers on each side when framed.

## 3 Sills

Specify the characteristics of fireplace **Sills**. A sill is only generated if a fireplace is raised sufficiently off the floor.

- Specify the **Thickness** of fireplace sills.
- Check **Double Sills** to specify a double sill for all fireplaces.

## BEAMS PANEL



**Floor/Ceiling Beams** and **Roof Beams** are not automatically generated: they can only be drawn manually. See *Manual Framing on page 854*.

 Posts and beams may be created under a Deck room automatically, depending on its size, location, and other variables. Deck Framing defaults are set in the Deck Room Defaults dialog. See *Deck Framing and Planking on page 425*.

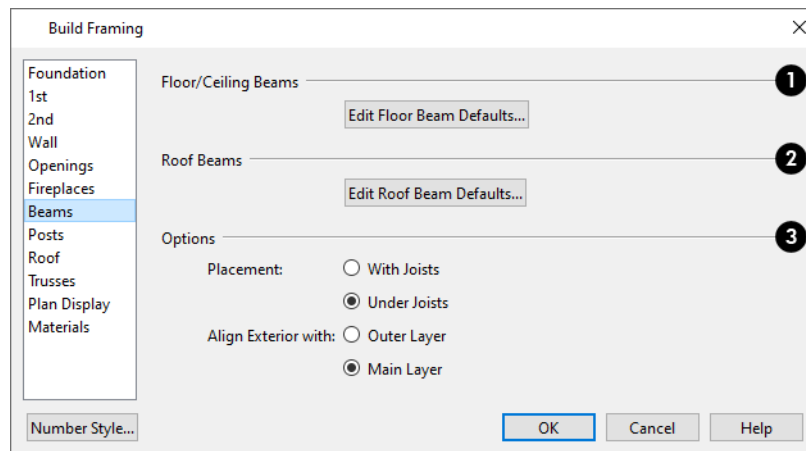

## 1 Floor/Ceiling Beams

Click the **Edit Floor Beam Defaults** to open the Floor/Ceiling Beam Defaults dialog. This dialog is similar to the Framing Specification dialog. See *Framing Specification Dialog on page 887*.

## 2 Roof Beams

Click the **Edit Roof Beam Defaults** to open the Roof Beam Defaults dialog. This dialog is also similar to the Framing Specification dialog.

## 3 Options

The **Options** settings affect the positioning of **Floor/Ceiling Beams**.

- Specify the **Placement** of Floor/Ceiling Beams relative to the joists. **With Joists** places beams at the same height as the joists so they hang on the beams; **Under Joists** places beams below joists so they bear on the beams. See [Bearing Lines on page 878](#).
- **Align Exterior with Outer Layer/Main Layer** - When a Floor/Ceiling Beam is drawn along and over an exterior wall, its exterior surface can snap to either the wall's outer layer or outer Main Layer, as specified here. See [The Main Layer on page 385](#).

## POSTS PANEL



**Posts** are not automatically generated: they can only be drawn manually. See [Manual Framing on page 854](#).

 Posts and beams may be created under a Deck room automatically, depending on its size, location, and other variables. Deck Framing defaults are set in the Deck Room Defaults dialog. See [Deck Framing and Planking on page 425](#).

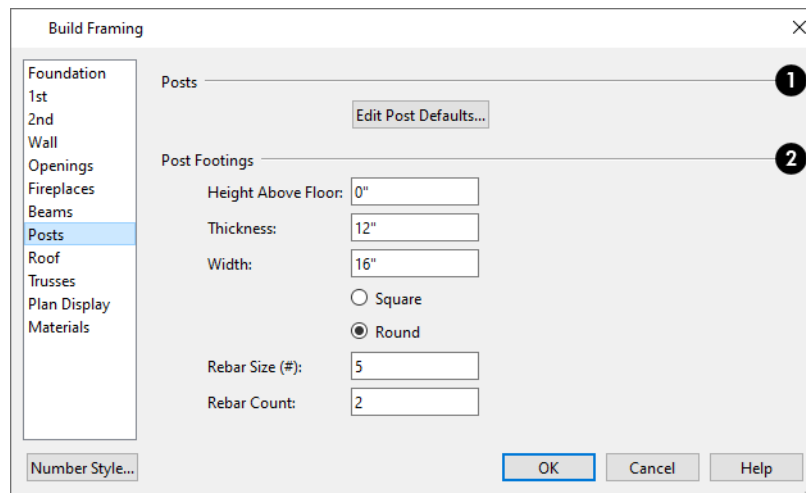

### 1 Posts

Click the **Edit Post Defaults** to open the Post Defaults dialog. This dialog is similar to the Framing Specification dialog for posts. See [Framing Specification Dialog on page 887](#).

### 2 Post Footings

The **Post Footings** settings control the initial attributes of footings created with the **Post with Footing**  tool.

- Specify the **Height Above Floor** value, measured from the top of the subfloor of the room in which the post is placed.
- Specify the top to bottom **Thickness** of the footing.
- Specify the **Width** of the footing. This is the length of each side of a square footing and the diameter of a round footing.
- Select the **Square** or **Round** radio button to specify the initial shape of post footings. Once created, a post footing can be edited like other closed polylines. See [Editing Closed Polyline-Based Objects on page 228](#).

- Specify the **Rebar Size Number** for post footing Rebar.
- Specify the **Rebar Count**, or number of bars, for Post Footings.

## ROOF PANEL

The settings on the ROOF panel of the Build Framing dialog are exactly the same as those on the STRUCTURE panel of the Build Roof dialog. See *Build Roof Dialog on page 797*.

These settings are also found on the STRUCTURE panel of the Roof Plane Specification dialog. Those settings that apply to ceiling planes are available in the Ceiling Plane Specification dialog. See *Roof Plane Specification Dialog on page 814*.

Note: Changes made on the Roof panel will not affect the structure of existing roof planes. To make changes take effect, rebuild the roof.

## 1 Automatic Roof Framing

Check **Automatic Roof Framing** to automatically rebuild roof framing if changes are made to the roof plan. See *Automatic Framing on page 854*.

- Check **Use Framing Reference** to use a Framing Reference Marker as the starting point for rafter layout. See *Framing Reference Markers on page 875*.

Note: Use Framing Reference is useful when framing a gable roof, but not necessarily a hip roof. See *Framing References and Roof Framing on page 876*.

## 2 Roof

- Check **Build Roof Framing** to build roof framing for the entire model. Not available in the Framing Defaults dialog. See *Roofs on page 791*.
- Uncheck **Angled Dormer Hole** to frame dormers using rafters under the dormer valleys and a double header where the peak of the dormer roof meets the main roof plane. When checked, a five-sided hole is framed with two angled double rafters located under the dormer valleys. If a double header does not fit within the main roof plane, an angled dormer hole is produced regardless of this setting.

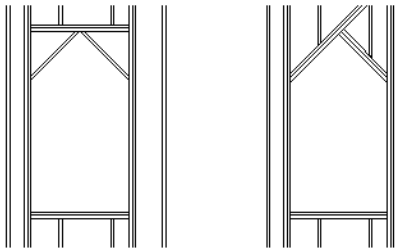

- Uncheck **Trim Framing To Soffits** to generate full-depth rafters all the way to the subfascia. If checked, rafter depths are trimmed to the top surface of the soffits in the eave area. Does not affect decorative rafter tail ends. See *Rafter Tails Panel on page 803*.
- Specify the **Spacing** of automatically generated rafters. This also sets the initial offset value for laying out rafters using the **Multiple Copy**  edit button. See *Multiple Copy on page 172*.
- Specify the **Maximum Lookout Spacing**. Depending on a roof plane's length, its lookouts may be spaced closer than this value, but not further.

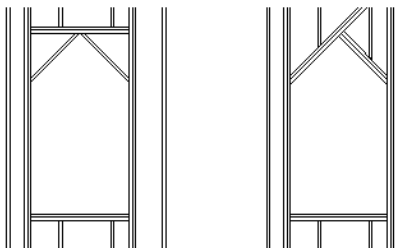

- Uncheck **Trim Framing To Soffits** to generate full-depth rafters all the way to the subfascia. If checked, rafter depths are trimmed to the top surface of the soffits in the eave area. Does not affect decorative rafter tail ends. See *Rafter Tails Panel on page 803*.

- Specify the **Spacing** of automatically generated rafters. This also sets the initial offset value for laying out rafters using the **Multiple Copy**  edit button. See [Multiple Copy on page 172](#).
- Specify the **Maximum Lookout Spacing**. Depending on a roof plane's length, its lookouts may be spaced closer than this value, but not further.

Specify the **Blocking Style**. See [Roof Blocking on page 858](#).

- Check **Vertical** to generate blocking that is oriented vertically, or plumb. When unchecked, blocking is perpendicular to the roof framing.
- **In Line** produces blocking pieces that align with each other.
- **Stagger** produces blocking that alternates on either side of the line you draw.
- **Cross/Bridging** produces cross bridging that looks like in line blocking in plan view, but shows as cross bridging in 3D views and the materials list.

### 3 Roof Layers

Define the layers of materials that together form the default roof plane assembly.

- The roof **Surface** depth displays here for reference. Click the **Edit** button to open the Roof Surface Definition dialog and define the layers of materials located above the structural layers. See [Material Layers Definition Dialogs on page 1040](#).
- The roof **Structure** depth displays here for reference. Click the **Edit** button to open the Roof Structure Definition dialog and define the layers of materials that form the roof structure.

When a roof plane or ceiling plane is located over a room with Flat Ceiling Over This Room unchecked, a ceiling surface on the underside of the plane will generate.

- When **Use Room Ceiling Finish** is checked, the ceiling finish layer is based on the specifications of the room(s) below. See [To create a cathedral ceiling on page 435](#).
- When Use Room Ceiling Finish is unchecked, the depth of the **Ceiling** finish depth displays for reference and can be edited here. Click the **Edit** button to define the material layers located below the structural layers in the Roof Ceiling Finish Definition dialog.
- Check **Soffits** to include soffits under the eaves and specify their **Thickness**. When Soffits is unchecked, rafter ends are exposed under the eaves and will display in 3D views when their layer is turned on. When this is the case, rafters will be assigned the same material as the Fascia when roof framing is generated. See [Rafter Tails on page 847](#).
- Check **Flat Under Eave Sub Fascia** to extend soffits downward until they meet the subfascia. When unchecked, soffits slope downward to the fascia, if the fascia depth is sufficient.

### 4 Roof Size

Specify the desired **Width** and **Depth** for **Rafters**, the **Ridge**, **Lookouts**, **Gable Sub Fascia**, **Eave Sub Fascia**, **Gable Fascia**, **Eave Fascia**, **Blocking**, and the **Shoe Plate**.

- The **Gable Sub Fascia** setting controls the height of both gable and eave soffits, and thus the depth of rafter tails when **Trim Framing to Soffits** is checked, above.
- Uncheck the boxes beside **Ridge**, **Lookout**, **Eave Sub Fascia**, **Gable Fascia** and/or **Eave Fascia** to prevent these framing members from generating when roof framing is built. When these boxes are checked, these items will generate as specified here.

- In the Ceiling Plane Specification dialog only, check **Include Ridges** to create ridge boards for the selected ceiling plane(s) when roof framing is generated.

## 5 Girder Trusses

Specify how hip-end girder trusses are generated.

- Specify the **Count**, which is how many trusses are generated side by side to produce a girder truss.
- Specify the **Distance from Wall Main Layer**, which is the distance from the outermost girder truss to the outside of the Main Layer of the wall that support the sub-girder trusses. When **Automatic** is checked, hip-end girder trusses are generated on layout, and approximately 4' (1200 mm) from the outside of the exterior of the wall's Main Layer.

## 6 Roof Overframing

These settings affect how roof framing is generated at locations where roof planes are drawn to represent an overbuild situation.

- Check **Roof Overframing** to generate shoe plates for the upper roof's rafters to join to in overbuild situations. When unchecked, no shoe plates are created.
- Specify the **Overframe Layer**, which is the layer of the lower roof assembly that the shoe plate snaps to when roof framing is generated.
- Select **Roof Finish** to generate overbuild framing on top of the topmost layer of the roof's Surface Definition.
- Select **Sheathing** to generate overbuild framing on top of the lowermost layer of the roof's Surface Definition.
- Select **Structural** to generate overbuild framing on top of the roof's Structure Definition.

## TRUSSES PANEL

Changes to the settings on this panel do not affect any trusses that are already present in the current plan. See [Trusses on page 894](#).



Chief Architect Premier does not engineer trusses. Always consult an engineer or truss company to have your trusses professionally designed.



The screenshot shows the 'Build Framing' dialog box with the 'Trusses' category selected in the left-hand menu. The dialog is organized into several sections, each with a circled number indicating a key setting:

- 1 Roof Trusses Member Depth:** Top Chord: 3 1/2", Bottom Chord: 3 1/2", Webbing: 3 1/2"
- 2 Roof Trusses Maximum Horizontal Span:** Top Chord: 60", Bottom Chord: 75"
- 3 Roof Trusses Options:**  Require Kingpost,  Energy Heel
- 4 Floor/Ceiling Trusses Member Depth:** Top Chord: 1 1/2", Bottom Chord: 1 1/2", Webbing: 1 1/2"
- 5 Floor/Ceiling Trusses Options:** Maximum Horizontal Span: 30",  Vertical Web

At the bottom of the dialog, there is a 'Number Style...' button, and 'OK', 'Cancel', and 'Help' buttons.

### 1 Roof Truss Member Depth

Roof trusses use the default Width setting for Rafters. See [Roof Panel on page 869](#).

- Specify the depth of the **Top Chord**. This value is the default roof plane Structure Thickness when the Framing Method is Trusses.
- Specify the depth of the **Bottom Chord**.
- Specify the depth of the **Webbing**.

### 2 Roof Truss Maximum Horizontal Span

These settings control the maximum distance between the junctions where webbing meets the **Top Chord** and **Bottom Chord**. Changing these values can create different truss configurations such as kingpost, queenpost, fink, double fink, fan, howe, or double howe.

These distances are measured horizontally for both roof and floor and ceiling trusses. In some instances, especially in more complex trusses, making these spans equal may result in the webbing appearing more normal or standard. See [Trusses on page 894](#).

### 3 Roof Truss Options

- Check **Require Kingpost** to include a central vertical webbing member. If this is unchecked, a vertical member may still be created, depending on the Maximum Horizontal Span settings and the length of the truss.
- Check **Energy Heel** to remove the bottom chord from the overhang area. For an energy heel to be modeled, the roof should also be raised off the top plates by at least 7", depending on the roof pitch. See [Energy Heels on page 909](#).

#### 4 Floor/Ceiling Truss Member Depth

- Specify the depth of the **Top Chord**.
- Specify the depth of the **Bottom Chord**.
- Specify the depth of the **Webbing**.

#### 5 Floor/Ceiling Truss Options

The **Maximum Horizontal Span** setting controls the maximum distance between the junctions where webbing meets the **Top Chord** and **Bottom Chord**.

### TRUSS SPACING

Trusses are always drawn manually, so while their depth, span and kingpost defaults are specified in the Build Framing dialog, their spacing is not.

Trusses are typically replicated using the **Multiple Copy**  edit button, and their spacing can be set in the Multiple Copy dialog. See [Multiple Copy Dialog on page 173](#).

### PLAN VIEW PANEL

The settings on the PLAN VIEW panel affect the appearance of Joists, Rafters, Trusses, and General Framing members in plan view. See [Displaying Framing on page 879](#).

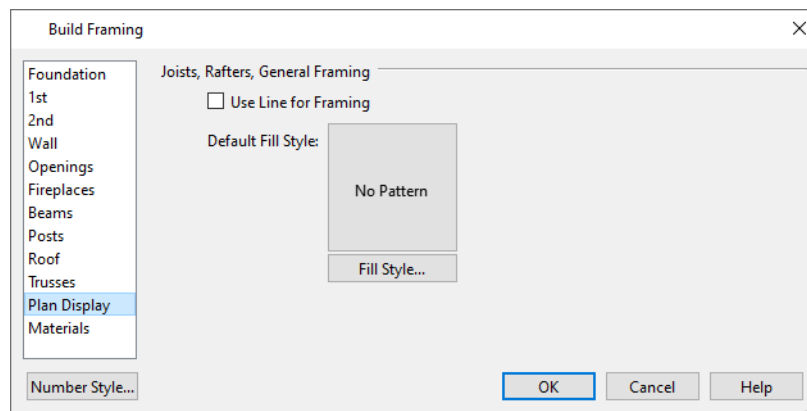

- Specify the **Default Fill Style** for joists, rafters, and General Framing members by clicking the **Fill Style** button to open the Default Framing Fill Style dialog. See [Displaying Framing on page 879](#).
- The Default Fill Style is not a dynamic default setting. Any framing already present in the plan will not be affected if you change it.
- Check **Use Line for Framing** to show joists, rafters, and General Framing members as single lines rather than as closed polylines. See [Displaying Framing on page 879](#).

Note: The Use Line for Framing setting is dynamic but affects the current floor only. The Default Fill Style setting affects all framing as it is created but is not dynamic.

## MATERIALS PANEL

The default materials that display on General Framing objects are specified on the MATERIALS panel. These materials are used in 3D views only and are not used in the Materials List. Materials List information is derived from the structure Type of each framing object. See *Framing and the Materials List on page 886*.

Changes made on the MATERIALS panel of the Build Framing dialog only affect subsequently created framing: both manually drawn and automatically generated.

The settings on this panel of the Build Framing dialog are the same as in many other specification dialogs. See *Materials Panel on page 1055*.

---

## Framing Reference Markers

 **Framing Reference Markers** are markers that specify the starting point for the layout of automatically-produced framing. See *Markers on page 529*.

In order for framing to be laid out relative to a Framing Reference Marker, it must be set to do so:

- Floor and ceiling framing as well as deck joists can be set to **Use Framing Reference** on a floor-by-floor basis in the Build Framing dialog. See *Floor Panels on page 860*.
- Roof framing can be set to **Use Framing Reference** plan-wide in the Build Framing dialog. See *Roof Panel on page 869*.
- Wall framing for individual walls can be set to **Use Framing Reference** in the Wall Specification dialog. See *Structure Panel on page 395*.

Each floor level can have its own Framing Reference Marker, which affects the layout of all framing members generated on that floor. If multiple markers are present on a given floor, the one that was created first is used and those created later are ignored. See *In Plan Views on page 879*.

In many cases, a single Framing Reference Marker can be used for the entire model. When this is the case, it must be placed on Floor 1.

Note: If no Framing Reference Markers exist in your plan, the point at 0,0 is used as the Framing Reference location for joists, while the framing for roof planes and walls generate relative to their parent object.

## USING FRAMING REFERENCE MARKERS

To place a Framing Reference Marker, select **Build> Framing> Framing Reference Marker** . Click in plan view to place the Framing Reference Marker and then build or rebuild some or all framing in the plan. Although Framing Reference Markers can be placed anywhere, a typical location is the corner of two exterior walls, at the exterior of their framing layer. See *Wall Type Definitions on page 384*.

When **Object Snaps**  are enabled, Framing Reference Markers snap to framing members and other CAD-based objects first, and then to a wall Main Layer surface or corner if possible. See *Object Snaps on page 160*.

Once placed, Framing Reference Markers can be modified just like other markers. See *Markers on page 529*.

When framing is generated using a Framing Reference Marker, the first framing member of a given type snaps to this point and all other framing members are laid out from there.

- Wall and roof framing snap to the Framing Reference Marker at their centers.
- Floor and ceiling framing snaps to the Framing Reference Marker at their centers when it is set to **Butt Over Support** in the Build Framing dialog. See [Floor Panels on page 860](#).
- Floor and ceiling framing snaps to the Framing Reference Marker along an edge when it is set to **Lap** over a supporting beam or wall. If **Lap** is selected, the surfaces where the joists lap are placed at reference spacing, so that joists are placed on either side of the framing reference locations.

## MOVE TO FRAMING REFERENCE



Manually drawn or edited framing as well as automatic framing that was not generated using a Framing Reference Marker can be moved relative to a Framing Reference Marker using the **Move to Framing Ref** edit button.

A group of selected framing objects that are all parallel to each other can be moved using the **Move to Framing Ref** edit button. Only one of the objects in the group is compared to the Framing Reference Marker and moved; the remaining objects are simply moved the same amount as the first object. Ideally, therefore, the group should have proper spacing relative to each other before the move.

### *To move framing objects to a framing reference marker*

1. Group select the framing objects.
2. Click the **Move to Framing Ref**  edit button.
3. The framing members are moved to the nearest Framing Reference Marker.

To determine placement, the **Move to Framing Ref** edit tool uses:

- For wall studs, the default **On Center Spacing** for wall framing, which is set in the Build Framing/Framing Defaults dialog. See [Wall Panel on page 863](#).
- For roof rafters, the **On Center Spacing** of the selected object's parent roof plane. See [Structure Panel on page 817](#).
- For floor and ceiling joists, the default **On Center Spacing** for the current floor set in the Build Framing/Framing Defaults dialog. They may instead reference spacing specific to a particular floor or ceiling platform. See [Joist Direction Lines on page 876](#).

## FRAMING REFERENCES AND ROOF FRAMING

Framing Reference Markers are useful when framing a gable roof, but not necessarily a hip roof. When a Framing Reference is used, common rafters on either side of a hip rafter will not meet in the same place.

If a Framing Reference Marker is not used, the automatic framing utility starts common rafter spacing from each end of the horizontal ridges, which results in common rafters on either side of hip jacks meeting each other.

---

## Joist Direction Lines



By default, automatically-generated floor and ceiling joists will run in the direction that results in the shortest span between bearing walls and/or beams. A **Joist Direction** line allows you to define the direction that joists in a particular floor or ceiling platform run, regardless of span.



To draw a Joist Direction line, select **Build> Framing> Joist Direction** , then click and drag as you would draw a CAD line. In order to have any effect, a Joist Direction line must be drawn within the area of a single floor or ceiling platform.

To avoid unexpected results, only one Joist Direction line should be present in a given floor or ceiling platform, and it should not extend outside the extents of that platform.

Joist Direction lines are located on the “Framing, Bearing Lines” layer by default and use the Text Style assigned to the layer that the Joist Direction line is on. See [Text Styles on page 538](#).

## MULTIPLE JOIST DIRECTIONS

By default, all of the rooms on each living floor share a single floor platform and a single ceiling platform. If you require joists that run in two directions in either of these platforms, begin by dividing the platform in question in two. There are a number of ways to do this:

- Divide the living area into separate rooms with different platform thicknesses and/or heights. See [Floor and Ceiling Platforms on page 428](#).
- Specify one or more interior walls as **Bearing Walls**. See [Structure Panel on page 395](#).
- Draw a **Floor/Ceiling Beam**  specified as a Bearing Beam. See [Floor/Ceiling Beam on page 859](#).
- Draw a **Bearing Line** . See [Bearing Lines on page 878](#).

Bearing Walls, Floor/Ceiling Beams, and Bearing Lines should be drawn on the same living floor as the joists they will interact with. Floor framing for a living floor is created on the floor below, while ceiling framing for a living floor is created on that floor. See [Floor and Ceiling Framing on page 851](#).

## JOIST SIZE AND SPACING

The text of a Joist Direction line states the platform framing’s Structure Type and size, and the spacing. By default, these values reflect the settings in the Framing Defaults dialog. See [Floor Panels on page 860](#).

In plans using US Units, when the Structure Type is “Lumber”, the nominal size will be reported for the joists. For all other Structure Types, fractional inches are used.

It is important to note that if a Joist Direction line is set to use non-default Spacing and Depth values, they will override the settings in both the Framing Defaults and Room Specification dialogs. It will not, however, change the settings in either dialog.

---

# Joist Direction Specification Dialog

 A Joist Direction line can control the joist depth and spacing in the floor or ceiling platform in which it is drawn. To change these values, select a Joist Direction line and click the **Open Object** edit button. The Joist Direction Specification dialog opens. See [Joist Direction Lines on page 876](#).

Any changes made in the Joist Direction Specification dialog will not affect any joists present in its floor or ceiling platform. Only subsequently produced framing in its platform will be affected.

## FLOOR JOIST PANEL

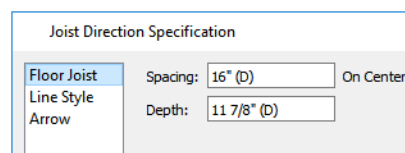

- Define the **Spacing** of the joists in the platform associated with the selected Joist Direction line.
- Define the **Depth** of these joists.

Note: This is not the recommended method for specifying joist depth and spacing in most cases. You should instead use the settings in the Room Specification dialog. See *Room Specification Dialog on page 437*.

## LINE STYLE PANEL

For information about the settings on this panel, see *Line Style Panel on page 305*.

## ARROW PANEL

Joist Direction Lines do not use the Attach or Auto Position options for arrows. For information about the settings on this panel, see *Arrowheads on page 327*.

---

# Bearing Lines

 It is not unusual for joists to lap or butt in the middle of a span rather than build across a platform. When they do, they typically bear on a wall or beam at that point. To produce joists that break over a support, specify the wall or beam in question as Bearing in its specification dialog:

- Check **Bearing Wall** in the Wall Specification dialog. See *Structure Panel on page 395*.
- Check **Bearing Beam** in the Framing Specification dialog. See *General Panel on page 887*.

Joists lap or butt over the support depending on the option selected in the Build Framing dialog. See *Floor Panels on page 860*.

In either case, the joists' overlap or butted ends are centered over the support. When an offset from the center is required, do not specify the wall or beam as Bearing and instead draw a **Bearing Line**.

A **Bearing Line** directs the program to lap or butt joists where they cross the line instead of framing across to a wall.

Select **Build> Framing> Bearing Line** , then click and drag to draw a Bearing Line as you would draw a CAD line. A Bearing Line should start outside the floor or ceiling platform and end outside it, passing completely through the building.

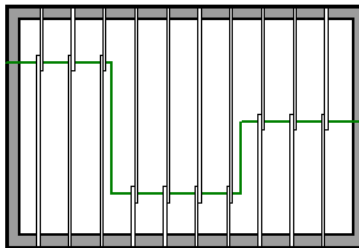

Bearing Lines are edited just like CAD lines, and can be connected to form polylines. See *Editing Line-Based Objects on page 216* or *Editing Open Polyline-Based Objects on page 224*.

Bearing Lines are one of the ways that a floor or ceiling platform can be divided into separate smaller platforms with different **Joist Directions** . See *Joist Direction Lines on page 876*.

## Displaying Framing



The display of framing members is controlled in the Layer Display Options dialog. By default, framing objects are created on one of over twenty layers with names that begin with “Framing,”: Ceiling Beams, for example, are placed on the “Framing, Ceiling Beams” layer. Once created, though, framing objects can be placed on any layer you wish. See [Layer Attributes on page 177](#).

### IN PLAN VIEWS

In plan views, wall studs and posts are represented by box-based CAD objects that look like Cross Boxes. See [Cross Box on page 320](#) and [Editing Box-Based Objects on page 232](#).

Joists, rafters, trusses, General Framing, and headers are represented in plan view by line-based CAD objects that are look like long, thin rectangles. See [Editing Line-Based Objects on page 216](#).

Note: The framing for the floor platform of a given floor level is drawn on the floor level below. See [Floor Panels on page 860](#).

You can specify a default fill style for line-based framing members in the Build Framing dialog. See [Plan View Panel on page 874](#), [Openings Panel on page 865](#), and [Fill Styles on page 192](#).

By default, newly drawn line-based framing members of a given type display in front of older ones. Posts, meanwhile, display in front of beams, but behind joists. You can specify the drawing order of framing members in their specification dialogs. See [Line Style Panel on page 889](#).

If you prefer, joists, rafters, trusses, and General Framing can instead be represented by a single line. The **Use Line for Framing** setting can be set differently for each floor in a plan. See [Plan View Panel on page 874](#).

### FRAMING LABELS

Framing labels are located on the “Framing, Labels” and “Framing Header Labels” layers and can be set to display in plan view, Wall Details, and cross section/elevation views. When a framing member with a label is selected, the label has a small square Move edit handle and a small rectangular Rotate handle.

- Headers, posts, and beams have automatic labels consisting of the object’s depth and width followed by the member type. In U.S. Unit plans, the nominal size is used when the framing Type is “lumber”.
- Automatic header labels include the total number of headers for the associated opening in parentheses. By default, only one header for a given opening displays a label while the other(s) are suppressed.
- Joists, rafters, studs, plates, and wall blocking do not have automatic labels; however, you can specify a custom label in their specification dialog. See [Label Panel on page 700](#).

Header label defaults can be set in the Door and Window Defaults dialogs, and can be preset for each door or window in its specification dialog. See [Framing Panel on page 573](#).

Framing objects have named value pairs associated with them, so you can create custom labels using Text Macros. See [Text Macros on page 540](#).

### IN 3D VIEWS

The easiest way to view framing in 3D is to use either the **Orthographic Framing Overview**  or **Perspective Framing Overview**  tool, which display the model using the "3D Framing Layer Set". See [Framing Overview on page 1088](#).



Framing objects can display in other 3D and cross section/elevation views, although by default they are not set to do so. If you wish to see framing in these views, turn on the framing layers in the appropriate layer set.

To reveal framing covered by other objects or wall layers, use the **Delete Surface**  tool. See [Delete 3D Surface on page 1099](#).

## IN CROSS SECTION/ELEVATION VIEWS

To display framing in a cross section/elevation view, make sure the framing layers are turned on in that view. See [Layer Display Options Dialog on page 179](#).

You can also use the **Delete Surface**  tool to temporarily delete the surfaces of wall layers or other objects that block the view.

In cross section/elevation views, horizontal framing objects that are cut by the cross section plane display as boxes containing an 'X'. **Wall Blocking** , **Joist Blocking** , and **Roof Blocking**  cut by the cross section plane displays as a box containing a single diagonal line. See [Cross Section/Elevation Views on page 1089](#).

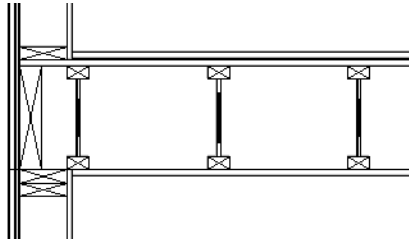



## IN WALL DETAIL VIEWS

Wall Details are a special type of elevation view in which only the studs, plates, girts, headers, and bridging used to frame an individual wall display. Each Wall Detail is created with a text object that reports which wall layer owns the framing as well as from which side of the wall the framing is being viewed. If the wall has more than one framing layer, they will all be drawn in the same Wall Detail view but will display separately, each described by its own text object.

A Wall Detail view for each framed wall in your plan is automatically created by the program when its wall framing is built. They are listed in the Project Browser, and the name of each Wall Detail is the same as the Automatic Label of the wall it is associated with.

There are several ways to open the Wall Detail associated with a wall:

- Select the wall and click the **Wall Detail**  edit button. See [Editing Walls on page 368](#).
- Right-click on the name of the detail in the Project Browser and select **Open View** from the contextual menu. See [Project Browser on page 58](#).
- Select a wall framing member in the Materials List and click the **Find Object in Plan**  edit button. See [Find Object in Plan on page 691](#).

To locate the owner wall of a selected wall framing member in the Wall Detail, a Framing Overview, or other 3D view in which wall framing can be seen, click the **Find Wall**  edit button. See [Selecting Walls on page 368](#).

The framing members of an individual wall can be selected and edited in its Wall Detail. If you rebuild wall framing after manually editing in a Wall Detail, your changes will be lost. To protect changes made to a wall's framing, check **Retain Wall Framing** in the Wall Specification dialog. See [General Panel on page 392](#).



Wall Details are the only views in which **Wall Bridging**  can be created. See [Wall Bridging on page 857](#).

Most wall framing members occupy the entire thickness of its wall layer. Some, notably doubled headers or corner sheetrock nailers, may be turned sideways. If a wall has multiple framing layers, they will display in the same Wall Detail view, but in separate locations. Double or triple headers display one behind the other in a Wall Detail. You can select them using the **Select Next Object**  edit button. See [Select Next Object on page 211](#).

By default, Wall Details show walls as viewed from the exterior. You can specify whether Wall Details are viewed from the interior or exterior in the Build Framing dialog. You can also specify the default fill style for framing objects in Wall Details. See [Wall Panel on page 863](#).

As with regular 3D views, Wall Details can be sent to layout and printed. See [Layout on page 1333](#) and [Printing and Plotting on page 1363](#).

## FRAMING MATERIALS AND TYPES

The appearance of a framing member in 3D and cross section/elevation views is affected by the material assigned to it and also by its Type.

The material specified for a framing member determines what it looks like in camera views by applying a texture, pattern, or color to its surface. Materials have no effect on how the framing is calculated in the Materials List, however.

The default materials for framing are set:

- In the Floor and Ceiling Structure Definition dialogs for floor and ceiling framing. See [Floor and Ceiling Platform Definitions on page 429](#).
- In the Wall Type Definitions dialog for wall framing. See [Wall Type Definitions Dialog on page 387](#).
- In the Framing Defaults dialog for General Framing, Posts, and Rafters. See [Materials Panel on page 875](#).

Framing Types can also influence how a framing member looks in camera views because some types have special profiles - for example, I-Joist, Steel-I, and C-Channel. Framing Types are also stated in the Description column in the Materials List. See [Structure Types on page 886](#).



In the Floor and Ceiling Structure Definition dialogs for floor and ceiling framing, the Framing Type provides an additional option: Truss, which allows you to automatically generated floor and ceiling trusses. See [Floor and Ceiling Trusses on page 895](#).

## IN THE MATERIALS LIST

When framing is calculated in the materials list, its dimensions and type are noted. Treated lumber is also counted separately from regular lumber. See [Structure Types on page 886](#).

Framing lengths can be counted using one of several methods to produce, for example, cut lists and buy lists. See [Structural Member Reporting on page 1306](#).

If framing is not present in a plan when a Materials List is created, it will not be calculated. See [Framing and the Materials List on page 886](#).

## FRAMING SCHEDULES



The **Framing Schedule** tool allows you to produce customizable framing schedules as well as framing labels that display schedule numbers. See *Schedules and Object Labels on page 681*.

Schedules of particular types of framing can be created by controlling which **Objects to Include** in the schedule. For example, a Deck Framing Schedule can be created by including “Deck” Objects while excluding all other Object types. See *General Panel on page 692*.

In plans using US Units, when a board’s Structure Type is “Lumber”, its nominal size will be reported in the Nominal column of a Framing Schedule. For all other Structure Types, fractional inches are used.

Framing schedules created in **Wall Detail**  views use a special **Only Include Objects from this Detail** setting and a selection of Objects to Include that report only wall framing members present in the current view. See *In Wall Detail Views on page 880*.

If placed into a Truss Detail, a framing schedule’s Objects to Include will be restricted to floor, ceiling, and roof trusses. **Only Include Objects from this Detail** is also used. See *Truss Details on page 901*.

---

## Editing Framing

Framing can be edited much like other line-based objects can using the edit handles, edit toolbar buttons, or the Framing Specification dialog. See *Framing Specification Dialog on page 887*.



Framing is organized into families which determine where it is generated and where it can be manually drawn. See *Manual vs. Automatic Framing on page 854*. Once framing has been created, however, it can be moved out of its structural component. In order to move roof framing above or below a roof plane, you must first check **Manual Rafter Height** in the Framing Specification dialog. See *Framing Specification Dialog on page 887*.

When **Start and End Indicators** are enabled in the Preferences dialog, a selected framing member will display an S and an E at its start and end points. This makes it easier to choose which end to lock when specifying its Length or Angle. See *Edit Panel on page 115*.

Roof and floor/ceiling trusses cannot be edited like regular framing members can and are discussed in their own chapter. See *Editing Truss Envelopes on page 900*.

## SELECTING FRAMING

Before a framing member can be edited, it must be selected. Framing can be individually selected in all views, and some types can be group-selected. To group-select framing in plan view, first select any of the Framing Tools. See *Marquee Select on page 213*.

To select framing objects of a particular type, use the **Marquee Select Similar**  tool’s **Restrictive Selection**  option. Wall framing can only be selected in this way in a Wall Detail view. See *Marquee Select Similar on page 214*.

## USING THE EDIT HANDLES

In plan view, framing members can be drawn, edited, and moved much the way CAD lines can. See *Editing Line-Based Objects on page 216*.

In cross section/elevation views, joists and rafters cut by the cross section and displaying a cross box can also be edited. See [Editing Box-Based Objects on page 232](#). Also, in cross section/elevation views headers can be edited like closed polylines. See [Editing Closed Polyline-Based Objects on page 228](#).

In a camera view or overview, the handles that display on a framing member depend on where it is clicked for selection and your current zoom factor.

- Click the top surface to display the same edit handles as in plan view, allowing you to rotate, move, and extend or shorten the length of the member.
- Click a side surface to display the same edit handles as in an elevation view, one at each end and one at the center.
- Zoom in and click on the appropriate edge to display edit handles that control the width and depth of framing members.

## USING THE EDIT TOOLS

A selected framing member can be edited in a variety of ways using the buttons on the Edit Toolbar. See [The Edit Toolbar on page 130](#).



**Move to Framing Reference** moves the selection into alignment with a Framing Reference Marker. See [Framing Reference Markers on page 875](#).



**Join and Lap Ends** and **Join and Mitre Ends** join horizontal framing members at either a lapped or mitered joint. See [Lapped and Mitered Joints on page 883](#), below.



## USING DIMENSIONS



Framing members can be both moved and resized using dimensions in plan view, elevation views, and Wall Details.

- See [Moving Objects Using Dimensions on page 483](#).

In order for a manually drawn Dimension Tool to locate framing objects as a dimension line is drawn, it must be set to do so in the Dimension Defaults dialog. See [Locate Manual Panel on page 454](#).

## LAPPED AND MITERED JOINTS



You can make two horizontal framing members meet at a lapped intersection using the **Join and Lap Ends** edit button.



### *To join and lap framing members*

1. Select a horizontal framing member such as a joist, rafter, beam, or General Framing object.
2. Click the **Join and Lap Ends**  edit button.
3. Click on a second horizontal framing member that is not parallel to the initially selected member.
4. The two members now meet at a lapped joint. The initially selected framing member butts against the second one, which laps the end of the first.



Alternatively, mitered joints can be created using the **Join and Mitre Ends** edit button. This edit tool is used in the same way as the Join and Lap Ends tool.

The **Join and Mitre Ends** and **Join and Lap Ends** tools not available for wall studs, Posts, Floor/Ceiling Trusses, or Roof Trusses.

Multiple framing objects can also be trimmed to length using the **Trim Object(s)**  and **Extend Objects**  edit tools.

See [Trim and Extend on page 272](#).

## STEEL AND CONCRETE

You can set framing defaults to generate steel framing and concrete structural members as well as lumber and other framing types. Individual framing members can also be specified as concrete or steel, as well.

When setting up defaults or modifying an individual object, make sure you specify both the desired framing Type and the material. See *Framing Materials and Types on page 881*.

## END PROFILES AND RAFTER TAILS

End profile cuts can be specified for rafters, beams, joists, and General Framing objects in the Framing Specification dialog. See *End Profile Panel on page 889*.

## DELETING FRAMING



Individual and group-selected framing members can be deleted the way other objects in the program are. See *Deleting Objects on page 284*.



Categories of framing, such as wall framing or floor and ceiling framing, can also be deleted in the Delete Objects dialog. See *Delete Objects Dialog on page 285*.

---

# Keeping Framing Current

When you modify your plan, move walls, raise or lower platforms or redesign the roof, any framing present in the plan will not update to reflect your changes. In order for the framing to be updated, you must regenerate automatically produced framing and either edit or delete and replace manual framing.

For this reason, it is recommended that you wait until your model is finished, or nearly finished, before creating framing. See *Drawing a Plan on page 27*.

## AUTOMATIC FRAMING

Automatically-generated framing can be rebuilt using either of two check boxes in the Build Framing dialog:

- Select a **Build** check box to build automatic framing once. For example, check **Build Wall Framing** on the WALL panel to build wall framing once based on the current state of the model. If the model is changed later, you may need to do this again.
- Select an **Automatic** check box to build automatic framing every time a change is made to that structural component in the plan. For example, check **Automatic Wall Framing** on the WALL panel to rebuild all wall framing any time a wall is affected by changes to the model.

When floor, ceiling or roof framing is regenerated, all automatically produced framing objects and any copies of them are deleted and new framing is calculated. See *Rebuilding and Retaining Framing on page 855*.

## MANUAL FRAMING

It is vital to remember that manually drawn framing objects and copies of them are not retained when automatic framing is rebuilt.

If a plan is not final, therefore, do not spend a lot of time altering or copying automatically produced framing objects. It is best to wait until your design is final before doing manual framing work.

## BUILD FRAMING FOR SELECTED OBJECT



If changes are made to a wall, floor platform, roof plane, or ceiling plane that require its framing to be rebuilt, you do not have to rebuild all of the framing in that object's category. Instead, select the object and click the **Build Framing for Selected Object** edit button. The floor framing for a selected room can be rebuilt in this manner, as well. See [Build Framing for Selected Object\(s\) on page 885](#).

---

## Build Framing for Selected Object(s)



The **Build Framing for Selected Object(s)** edit tool allows you to build or rebuild the framing for a selected wall, floor platform, Roof Plane, Ceiling Plane, or Tray Ceiling Polyline. It also allows you to ensure that a truss's envelope and webbing are up-to-date.

Note: The **Build Framing for Selected Object(s)** edit tool is not available if the selected object has **Retain Framing** specified. See [Rebuilding and Retaining Framing on page 855](#).

## FRAMING FOR WALLS

The **Build Framing for Selected Object(s)** edit tool is available for walls using a framed wall type and for railings specified as Solid, but not for other types of walls and railings. See [Wall Type Definitions on page 384](#).

## FRAMING FOR ROOMS

The **Build Framing for Selected Object(s)** edit tool is only available for rooms that have **Floor Under This Room** checked, **Monolithic Slab Foundation** unchecked, and a framing material specified in its Floor Structure Definition. See [Structure Panel on page 439](#).

If the selected room is adjacent to other rooms that are in the same Framing Group, the program will ask whether you would like to create a new Framing Group for the selected room:

- Click Yes to create a new Framing Group, assign the selected room to it, and generate floor framing for that room.
- Click No to generate floor framing across the entire platform using the existing Framing Group assignments.

See [Framing Groups on page 851](#).

## TRAY CEILING POLYLINES

The **Build Framing for Selected Object(s)** edit tool will generate framing for the side walls and ceilings of a selected Tray Ceiling Polyline. This button is not available, however, if the selected Tray Ceiling Polyline has a Caution  symbol indicating that its shape or position is not supported. See [Tray and Coffered Ceilings on page 430](#).

## REBUILDING TRUSSES

If you make changes to a selected truss that affect its envelope or webbing, click the **Rebuild Framing for Selected Object(s)** edit button to ensure that its configuration is up-to-date. This performs the same action as checking **Force Truss Rebuild** in the Truss Specification dialog. See [Editing Truss Envelopes on page 900](#).

---

## Framing and the Materials List

Each framing member created in a plan is counted in the Materials List. See [Materials Lists on page 1303](#).

Framing can be calculated using one of several reporting methods. See [Structural Member Reporting on page 1306](#).

Depending on what a framing member is used for, it may be listed in the Framing (F), Subfloor (SF), or Roofing (R) category. See [Categories on page 1311](#).

- Framing includes all wall framing, posts, and General Framing objects.
- Sub Floor lists floor and ceiling framing joists as well as sheathing.
- Roofing includes trusses, rafters, and sheathing.

It is important to note that the floor, ceiling, and roof framing counted in the Materials List may vary considerably depending on whether framing of those types is actually present in the plan:

- If no framing is present in the model, then the required floor, ceiling, and roof framing is estimated. Total linear footage for various depths of rafters and joists is estimated, rather than a quantity of specific lumber lengths and sizes. Wall framing is not estimated.
- If even one floor, ceiling, or roof framing object exists in the plan, then objects in that category are counted instead of estimated for the Materials List.

### STRUCTURE TYPES

A variety of structural member Types is available for use in Chief Architect Premier. They fall into four categories:

- Wood framing types: Lumber, I-Joist, Glulam, Engineered Lumber, LVL, PSL, and VSL.
- Steel framing types: Steel I, Steel Box, C Channel, and U Channel.
- Solid Concrete.
- Round (Posts only).

You can select any of these Types as the default for floor and ceiling framing, headers, roof framing, beams, and posts. See [Build Framing Dialog on page 860](#).

You can also specify the Type for individual framing members in their specification dialog. See [General Panel on page 887](#).

Changing the framing member Type does not affect how framing is placed, but it may change its profile in cross section and 3D views and will affect its description in the Materials List.

The framing member Type does not affect the appearance of the material used by a framing member in 3D views. See [Framing Materials and Types on page 881](#).

### STRUCTURAL MEMBER REPORTING

You can specify whether framing materials are calculated by linear foot, as a cut list, or as a buy list. See [Structural Member Reporting on page 1306](#).

### FRAMING MATERIALS AND THE MATERIALS PANEL

The materials applied to framing objects in 3D views are not used in the Materials List. Materials List information is derived from the structural use of each framing object and its **Type** - not the material seen on its surfaces in 3D views. See [Materials Panel on page 875](#).

# Framing Specification Dialog

Select a framing member and click the **Open Object** edit button to open the Framing Specification dialog for the type of framing member selected.

The settings in this dialog are similar to those in the Post and Beam Specification and Defaults dialogs. See *Framing with Beams on page 856*.

You can also open the specification dialog for the framing objects(s) associated with a schedule row. See *Open Row Object(s) on page 686*.

The panels available in the Framing Specification dialog will vary, depending on the type of framing object that is selected.

## GENERAL PANEL

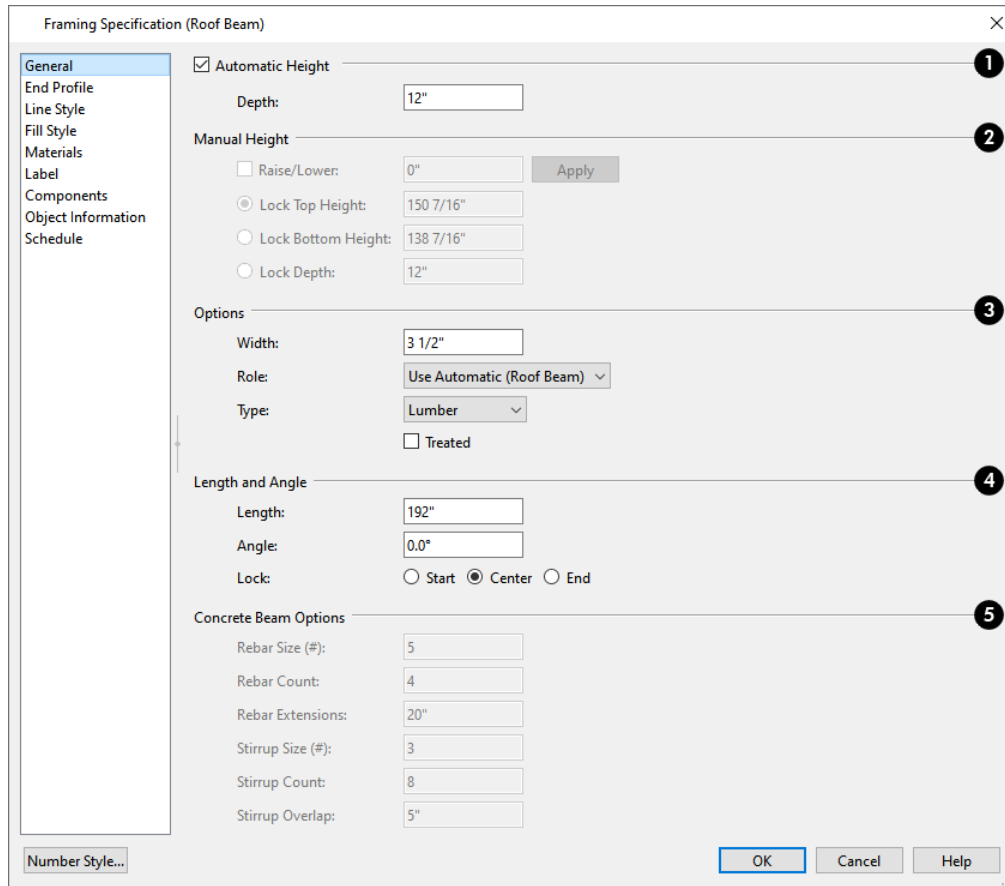

The options available in on the GENERAL panel will vary depending on the type of framing member selected.

### 1 Automatic Height

- When **Automatic Height** is checked, the selected Roof Rafter, Roof Beam, or Roof Blocking object generates within the structural layer of the roof plane(s) it is drawn in. Uncheck this box to enable the Manual Height settings

that follow.

- If the selected object's height is edited outside this dialog, Automatic Height will become unchecked automatically.

## 2 Depth and Height

- Check the box beside **Raise/Lower**, then enter a positive value to raise or negative value to lower the framing object from its current position. The amount is added to both the Top and Bottom Heights when you click either **Apply** or **OK**, and does not affect the Depth. When Raise/Lower is checked, the other Depth and Height settings are disabled.
- Select the radio button beside one of the height values to **Lock** it, then change a value that remains available.
- Specify the **Top Height** of the post, as measured from the first floor subfloor at 0". For a rafter, this is the top height at its low end.
- Specify the **Bottom Height** of the post, as measured from the first floor subfloor at 0". For a rafter, this is the bottom height its low end.
- Specify the **Depth** of the framing object. For a rafter, this is the depth measured perpendicular to the roof plane.
- **Manual Rafter Height** - Normally, the height of each Rafter or Roof Beam end is reset after any move or edit so that it is located just under the roof surface. Check this box to allow the height of the object to be changed. Only available for Rafters and Roof Beams.

## 3 Options

- Set the framing member's **Width**, as seen in plan view.
- Specify a selected wall framing member's **Thickness**, as seen in plan view. Only available for wall framing.
- Select the selected framing member's structural **Role** from the drop-down list. See *Framing Types and Roles on page 853*.
- Select a structural member **Type** from the drop-down list. The Round Type is unique to Posts. See *Structure Types on page 886*.
- Check **Show Cross** to display the selected Post as a cross box in plan view. Only available for Posts. See *Displaying Framing on page 879*.

Note: Instead of counting individual concrete posts and beams in the Materials List, the total volume of their concrete is calculated. The square footage for beam and post forms is also listed.

- Check **Bearing Beam** to specify the selected Floor/Ceiling Beam as a load-bearing beam. When checked, automatically generated joists run perpendicular to the selected beam and either lap or butt over it, as specified in the Build Framing dialog. If the beam's Top Height is at least 1" higher than the joists' bottom height, the joists will instead butt against the sides of the beam. See *Framing with Beams on page 856*. Only available for Floor/Ceiling Beams.
- Check **Treated** to specify that the selected framing member be counted as treated in framing schedules and the Materials List.
- The **Rotate** options let you rotate and align a selected wall stud, blocking, or header within the wall's framing layer. Select **None** for the framing member's Thickness to span the depth of the framing layer; select **Flat to Outside** to rotate the member 90° and align it with the outside of the framing layer; select **Flat to Inside** to rotate the member 90° and align it with the inside of the framing layer.



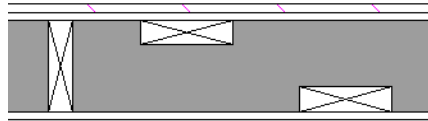

#### 4 Length and Angle

Lock the point about which you want like the selected object to resize and/or rotate, then specify its exact length and angle. See [Editing Framing on page 882](#).

- Specify the **Length** of the framing object. Rafter length is measured along the top of the rafter, and so is greater than the length measured in plan view. Not available for Posts.
- **Width 1** and **2** - Specify the Post width in each dimension. When a Round Post is specified, Width 1 refers to its diameter and Width 2 is not available.
- Specify the **Angle** of the framing object in plan view. Changing this rotates the object about the location specified by the radio buttons described below.
- Select **Lock Center** to resize or rotate the object about its center point.
- Select **Lock Start** to resize or rotate the object about the location from which you started drawing the framing object.
- Select **Lock End** to resize or rotate the object about the location where you stopped drawing it.

#### 5 Concrete Beam Options

Specify the **Rebar** and **Stirrups** for concrete Posts and Beams. These settings are only available when the selected object is a Post or Beam and “Solid Concrete” is selected from the Type drop-down list.

- Specify the **Size Number** for both Rebar and Stirrups.
- Specify the **Count**, or number of bars, for both Rebar and Stirrups.
- Specify the length of Rebar **Extensions**.
- Specify the distance that Stirrups **Overlap**.

### RAFTER TAILS PANEL

The RAFTER TAILS panel is only available for rafters, rafter lookouts, and subfascia. The settings here allow you to specify a rafter tail profile for exposed end rafter ends under roof eaves. The default Rafter Tail profile can be specified in the Build Roof dialog. See [Rafter Tails Panel on page 803](#).

### END PROFILE PANEL

The END PROFILE panel is available for joists, beams, and General Framing members. The settings here allow you to specify a decorative profile for one or both ends of these objects. The default profile for beams can be set in the Floor Beam, Roof Beam, and Deck Beam Defaults dialogs. See [Moldings // Profiles / Rails / Panels on page 927](#).

### LINE STYLE PANEL

The settings on the LINE STYLE panel affect the selected object’s line style, its bumping behaviors, and its drawing order. See [Line Style Panel on page 305](#).

## FILL STYLE PANEL

For floor, ceiling, and roof framing, and General Framing, the settings on the FILL STYLE panel affect the selected object's appearance in plan view. See *Fill Style Panel and Dialogs on page 193*.

For studs and other wall framing that displays as a cross box in plan view, the settings on this panel affect the selected object's appearance in Wall Details. See *In Wall Detail Views on page 880*.

For headers only, the FILL STYLE panel allows you to control the appearance of the selected object in both plan view and Wall Details. Click either of the **Fill Style** buttons to open the Plan View Fill Style or Wall Detail Fill Style dialog.

## MATERIALS PANEL

The default materials on this panel are set in the Build Framing dialog. If you change the selected object's framing Type, the material here may update - unless you have previously specified a non-default material. See *Materials Panel on page 1055*.

## LABEL PANEL

Framing labels can display in plan view and cross section/elevation views when the "Framing, Labels" layer is turned on and use the Text Style assigned to that layer. See *Text Styles on page 538*.

Automatically generated wall framing can also display in Wall Detail views. When accessed from a Wall Detail, this panel will have Wall Detail Position and Orientation settings.

For more information about the settings on this panel, see *Label Panel on page 700*.

Note: If a framing member is listed in a schedule using callout labels, the settings here are overridden and the schedule label is used instead.

## COMPONENTS PANEL

The information on the COMPONENTS panel can be used in the materials list. For more information, see *Components Panel on page 1330*.

## OBJECT INFORMATION PANEL

The information entered on the OBJECT INFORMATION panel can be used in schedules and the materials list. For more information, see *Object Information Panel on page 1331*.

## SCHEDULE PANEL

The settings on the SCHEDULE panel determine which schedule categories the selected object is included in. See *Schedule Panel on page 704*.

---

# Export to EasyFrame





The EasyFrame Automated Marking System is a machine used for cutting construction framing parts and putting layout markings on those parts. You can export wall framing information from a Chief Architect plan for use in this system. For more information, visit: [www.easyframesaw.com](http://www.easyframesaw.com).

## BEFORE EXPORTING

Before exporting to Easy Frame, you need to prepare your plan so the exported data meets your needs.

### *To prepare wall framing for export to EasyFrame*

1. Draw the plan as you normally would.
2. Uncheck **Auto Merge Collinear Walls** in the General Wall Defaults dialog. See *General Wall Defaults on page 343*.
3. Use the **Add Break** edit tool to create wall segments that correspond to the panels or plate lengths you want. See *Add Break on page 254*.
4. Build wall framing. See *Build Framing Dialog on page 860*.
5. Inspect the framing and make any changes that you may need. See *Editing Framing on page 882*.
6. Export the wall framing information to EasyFrame:
  - Select **File> Export> Export All Wall Framing to EasyFrame**  to export information about all wall framing in the plan.
  - Select one or more walls that you would like to export the framing information for and click the **Export All Wall Framing to EasyFrame**  edit button. See *The Edit Toolbar on page 130*.

## EXPORT TO EASYFRAME DIALOG



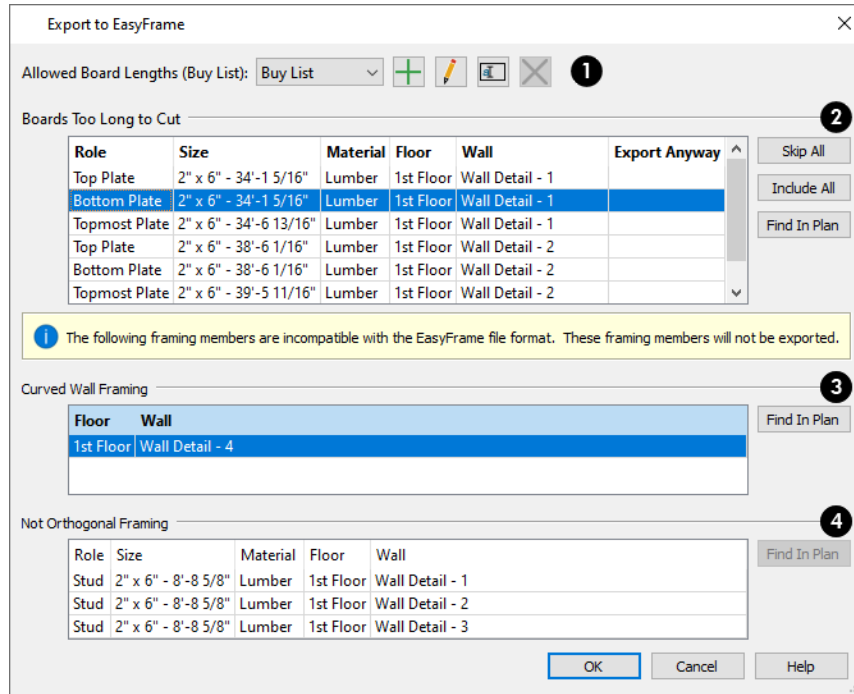

To export a plan's wall framing information for use with EasyFrame, select **File> Export> Export All Wall Framing to EasyFrame** . Chief Architect Premier exports using the **.ezf** file format.

You can also select one or more walls in a plan and click the **Export Selected Wall Framing to EasyFrame**  edit button.

The Export to EasyFrame dialog reports any wall framing boards that either cannot be exported to EasyFrame or may be too long to cut from a longer board.



## 1 Allowed Board Lengths

- Select a Buy List from the **Allowed Board Length (Buy List)** drop-down list to specify the available board lengths that wall framing can be cut from. See *Structural Member Reporting on page 1306*.
- Click the **Add**  button to create a new Buy List based on the one that is currently selected. Type a short, descriptive name for the new Buy List, then modify its settings as needed.
- Click the **Edit**  button to open the Structural Member Reporting dialog for the selected Buy List and make any changes you may need.
- Click the **Rename**  button to type a new name for the selected Buy List.
- Click the **Delete**  button to remove the selected Buy List from the list of those available in the current plan. If a Buy List is either set as the default or in use by a Materials List, it cannot be deleted.

## 2 Boards Too Long to Cut

Boards that are too long to be cut from available lengths can be exported to EasyFrame, but are not set to do so by default.

- Click the **Add**, **Edit**, **Rename**, or **Delete** button to manage the list of available Buy Lists in the current plan.
- The Labels of any walls in the plan with boards that are too long to be cut from any of the boards in the selected Allowed Board Length Buy List are listed here. See *Wall Labels on page 364*.
- By default, no walls in this list will be included in the export. Click on a line item to select it, then click in the **Export Anyway** column to add a check mark and include it in the export.
- With a line item selected, click the **Find in Plan** button to close the dialog and select the wall in question in plan view. See *Finding Objects on page 211*.

- Click the **Skip All** button to clear remove all check marks from the Export Anyway column.
- Click the **Include All** button to add check marks in the Export Anyway column for all line items.

### **3 Curved Wall Framing**

Framing in curved walls cannot be exported to EasyFrame. This section will only be present in the dialog if there are one or more curved walls in the plan. See *Drawing Curved Walls on page 360*.

- The Labels of any curved walls in the plan are listed here.
- Select a line item in the list and click the **Find in Plan** button to close the dialog and select the wall in question in plan view.

### **4 Not Orthogonal Framing**

Framing that is not orthogonal to the direction of its parent wall cannot be exported to EasyFrame. This section will only be present in the dialog if there are one or more walls in the plan that have non-orthogonal framing members. See *Editing Framing on page 882*.

- The Labels of any walls in the plan that have non-orthogonal framing members are listed here.
- Select a line item in the list and click the **Find in Plan** button to close the dialog and select the wall in question in plan view. See *Finding Objects on page 211*.

When you click OK, the Save EasyFrame File dialog opens. This is a typical Save File dialog. See *Saving, Exporting, and Backing Up Files on page 39*.

If any excluded boards are listed in this dialog when you click OK, a Confirmation message will first ask whether you want to continue.

# Trusses

## Chapter 25

There are two basic ways to frame a roof. The first is commonly called “stick framing,” or sometimes “handstacking” or “cut-and-stack.” This type of roof incorporates framing such as rafters, ridges, and ceiling joists. See *Framing on page 850*.

The other method is to use prefabricated, engineered roof trusses. Chief Architect allows you to design and display a wide variety of trusses.

### DISCLAIMER

Chief Architect does not engineer trusses. The trusses displayed by Chief Architect are for illustrative purposes only. They can show how trusses are used in your plan, and help you communicate to the licensed engineer who produces your final truss design where you want your trusses and how you would like them to work.

Always have your truss designs approved by a licensed engineer.

### TOPICS



<b>Truss Defaults</b> .....	<b>895</b>
<b>Floor and Ceiling Trusses</b> .....	<b>895</b>
<b>Roof Trusses</b> .....	<b>895</b>
<b>Drawing Trusses</b> .....	<b>896</b>
<b>Displaying Trusses</b> .....	<b>897</b>
<b>Editing Trusses</b> .....	<b>898</b>
<b>Editing Truss Envelopes</b> .....	<b>900</b>
<b>Truss Details</b> .....	<b>901</b>
<b>Truss Labels</b> .....	<b>902</b>
<b>Mixing Trusses with Stick Framing</b> .....	<b>902</b>
<b>Truss Bases</b> .....	<b>903</b>
<b>Truss Base Specification Dialog</b> .....	<b>907</b>
<b>Hip Trusses</b> .....	<b>908</b>
<b>Special Roof Trusses</b> .....	<b>909</b>
<b>Roof Truss Specification Dialog</b> .....	<b>912</b>
<b>Floor/Ceiling Truss Specification Dialog</b> .....	<b>916</b>
<b>Framing and Truss Schedules</b> .....	<b>919</b>

---

## Truss Defaults



The default settings for floor, ceiling and roof trusses are set in the Framing Defaults dialog. Select **Edit> Default Settings** and in the Default Settings dialog, select Framing and click the **Edit** button.

- The default settings for truss chord and webbing depth, maximum span, and kingpost are set in the Framing Defaults dialog. See [Trusses Panel on page 872](#).
- The overall depth of individual **Floor/Ceiling Trusses**  are based on the thicknesses of the platforms in which they are drawn. See [Floor Panels on page 860](#).
- The structure of **Roof Trusses**  is determined by the position of the roof plane(s) above and the ceiling plane(s) below. See [Roof Planes on page 804](#) and [Ceiling Planes on page 826](#).

You can also set the **Heel Height** for Roof Trusses in the Build Roof dialog. See [Roof Panel on page 798](#).

---

## Floor and Ceiling Trusses

 Floor and ceiling trusses can be used instead of joists to frame platforms. As with floor and ceiling joists, the presence of a room above determines whether a platform is a floor or a ceiling and thus, whether a floor or ceiling truss is drawn. For example, a truss drawn on the first floor of a single story home will be a ceiling truss, while a truss drawn on the first floor of a two-story building will be a floor truss for the 2nd floor.

A floor or ceiling truss can only exist in a floor or ceiling platform. The vertical depth of the truss is defined by the Thickness of the platform's framing layer, so if you intend to use floor/ceiling trusses you should set your platform depths accordingly. See [Floor and Ceiling Platforms on page 428](#).

To generate floor and/or ceiling trusses automatically in a platform, select "Truss" as the Structure Type for the platform structure's Framing layer and then use the Build Framing dialog to generate floor/ceiling framing. See [Floor Panels on page 860](#).

To draw a floor or ceiling truss manually, select **Build> Framing> Floor/Ceiling Truss** , then click and drag within a floor or ceiling platform in plan view. A Framing layer in the platform structure is required; however, its Structure Type does not have to be "Truss". See [Drawing Trusses on page 896](#).



To create a sloped ceiling truss, draw a Roof Truss and specify it as a Sloping Flat Truss. See [General Panel on page 912](#).

The TRUSSES panel of the Build Framing dialog contains default settings for floor and ceiling trusses. See [Trusses Panel on page 872](#). These default settings can be overridden by the settings in the Floor/Ceiling Truss Specification dialog. See [Floor/Ceiling Truss Specification Dialog on page 916](#).

---

## Roof Trusses

 Roof trusses can be used instead of or in combination with rafters to frame roofs and ceilings. Roof trusses can be automatically generated or drawn manually, and can only be created where a roof and ceiling are already present. To draw a roof truss, select **Build> Framing> Roof Truss**, then click and drag in plan view within one or more roof planes. See [Drawing Trusses on page 896](#).

If you intend to use roof trusses, you should build your roof planes with this in mind:

- Before building the roof, select **Trusses** as the roof Framing Method in the Build Roof dialog. When this is selected, roof plane Structure Thickness is based on the default **Top Chord Depth** set in the Framing Defaults dialog. See [Trusses Panel on page 872](#).
- If **Rafters** is selected as the Framing Method, roof Structure Thickness is determined by the rafter **Depth** setting on the ROOF panel of the Framing Defaults dialog.
- If you plan to use both trusses and rafters, build the roof using Rafters as the Framing Method and then manually edit the roof planes that will receive trusses. You can specify a roof plane's Framing Method in its specification dialog. See [General Panel on page 814](#).

Bear in mind that if the bottom chords of trusses form the framing for a ceiling platform, ceiling joists in that platform will not automatically generate. See [Floor and Ceiling Framing on page 851](#).

## ROOF TRUSS PLACEMENT

A roof truss can only exist in a space defined by the roof planes above it and the ceiling or manually drawn **Ceiling Plane**  below it. Roof trusses can also be created over a room with Flat Ceiling Over This Room specified provided that there is a roof directly above. This is because the shape of a truss is defined by the space between the roof above and the ceiling below.

If the program either does not find both roof and ceiling planes, or if there is not enough room between them to model a truss, a warning message displays. For example, if you draw a truss in a roof overhang where there is no ceiling, this message displays:

“Roof and ceiling surfaces too close together or cannot be found, so cannot make truss.”

The problem truss may still display in plan view with a label of the form “TR-\*”. If it does, it should be either moved or deleted. See [Editing Trusses on page 898](#).

One or both ends of a truss may be truncated if they are drawn across another truss. If this happens, it will end exactly on the surface of the existing truss, producing a girder truss. See [Girder Trusses on page 911](#).

Trusses can end on interior walls. You can draw a truss that partially crosses the building by starting and/or ending it within 24” (600mm) of an interior wall. The truss extends over the wall’s Main Layer. Its end lines up with the Main Layer surface on the far side of the wall.

## ROOF TRUSS WEBBING

The webbing in a newly drawn truss is controlled by the **Top Chord** and **Bottom Chord** settings in the Framing Defaults dialog. See [Trusses Panel on page 872](#).

Changing these default values may cause different truss configurations such as kingpost, queenpost, fink, double fink, fan, howe, or double howe to be represented.





---

## Drawing Trusses

Trusses can be generated automatically or drawn manually and replicated. Trusses are drawn similar to the way CAD lines are and can be drawn in plan view only. See [Draw Line on page 300](#).





### ***To draw and replicate trusses***

1. Select either the **Floor/Ceiling Truss**  or **Roof Truss**  tool, then click and drag within either a floor/ceiling platform or one or more roof planes.
  - As they are drawn, roof trusses will snap to any walls that they cross.
  - When a roof truss ends over an exterior wall, it will extend into the roof eave, stopping at the inside edge of the Eave Sub Fascia.
  - When a roof truss is drawn over a Full Gable Wall, it will have **End Truss** and **Reduced Gable** checked automatically.
  - Floor/Ceiling trusses will snap to the wall surfaces, the exterior surface of a wall's Main Layer, as well as to a variety of CAD-based objects, and can be drawn to any length.
2. Reposition the truss:
  - Floor/ceiling trusses are often positioned relative to an exterior wall or **Framing Reference Marker** . See [Framing Reference Markers on page 875](#).
  - Roof trusses are can be positioned over a gable end wall or at the ridge end of a hip.
3. Open the truss's specification dialog and edit its settings to meet your needs. See [Roof Truss Specification Dialog on page 912](#) or [Floor/Ceiling Truss Specification Dialog on page 916](#).
4. Make multiple copies of the truss at specified intervals using the **Multiple Copy**  edit tool.

The copies of Roof Trusses automatically conform to the structural conditions in their new locations. As a result, replicated Roof Trusses and their labels may be different from the original. See [Truss Labels on page 902](#).

Unlike Roof Trusses, Floor/Ceiling Trusses do not conform to new structural conditions when they are either moved or copied. See [Moving Trusses on page 899](#).

### ***To replicate trusses using Multiple Copy***

1. Select the truss to be copied in plan view.
2. Click the **Multiple Copy**  edit button.
3. Click the **Multiple Copy Interval**  edit button to open the Multiple Copy dialog. See [Multiple Copy on page 172](#).
4. Enter the correct spacing in the **All Trusses** box. Once set, click **OK**.
5. Select the truss and use the Move edit handle to drag it perpendicularly. The pointer becomes a four-headed arrow  when it is over the Move handle.
6. New trusses appear as you drag. Drag as far as necessary to produce all desired trusses. Each truss is created according to the particular Roof/Ceiling/Truss Base planes above and below it.

---



## **Displaying Trusses**



The display of trusses and their labels is controlled in the Layer Display Options dialog. See [Layer Display Options Dialog on page 179](#).

Truss labels display in plan view, cross section/elevation views, and the Truss Detail, and are used in the Materials List as well as in schedules. See [Truss Labels on page 902](#).

## IN 3D VIEWS

The easiest way to view trusses in 3D is to use either the **Orthographic Framing Overview**  or **Perspective Framing Overview**  tool, which display the model using the 3D Framing Set layer set. See *Framing Overview on page 1088*.

Trusses can display in other 3D and cross section/elevation views, although by default they are not set to do so. If you wish to see trusses in these views, turn on the “Framing, Trusses” layer in the appropriate layer set.

You can create exposed trusses by placing roof and ceiling planes to produce the desired truss structure, drawing the trusses, and then removing the ceiling. See *Vaulted and Cathedral Ceilings on page 435*.

To reveal trusses covered by other objects, you can use the **Delete Surface**  tool. See *Delete 3D Surface on page 1099*.

## IN THE TRUSS DETAIL

All the floor, ceiling and roof trusses present in the current plan display in the Truss Detail, which is a special CAD Detail window in which a diagram of each truss configuration present in the plan is automatically generated. See *Truss Details on page 901*.

## IN THE MATERIALS LIST

All trusses are listed under the Roofing category in the Materials List. Their labels appear in the Size column, along with their length. See *The Materials List Tools on page 1304*.

## IN SCHEDULES

Floor, ceiling and roof trusses can be listed in schedules. See *Schedules and Object Labels on page 681*.

---

# Editing Trusses

Trusses can be edited much like other objects can using the edit handles, edit toolbar buttons, or the Truss Specification dialogs. See *Roof Truss Specification Dialog on page 912* and *Floor/Ceiling Truss Specification Dialog on page 916*.

## SELECTING TRUSSES

Before a truss can be edited, it must be selected. Like other architectural objects, Trusses can be individually and group-selected in all views. See *Selecting Objects on page 210*.

To group-select trusses of a particular type, use the **Marquee Select Similar**  tool. See *Marquee Select Similar on page 214*.

When **Start and End Indicators** are enabled in the Preferences dialog, a truss selected in plan view will display an S and an E at its start and end points. See *Edit Panel on page 115*.

Trusses can be deleted individually, or all at once in the Delete Objects dialog. See *Delete Objects Dialog on page 285*.

## USING THE EDIT HANDLES

In plan view, trusses can be drawn, edited, and moved much the way CAD lines can. See [Editing Line-Based Objects on page 216](#).

When editing a roof truss's length, bear in mind that if you position either of its ends at a location that doesn't correspond to a roof plane edge, interior wall, or another truss, **Use Special Snapping** will automatically become unchecked in its specification dialog.

When selected in a camera view, a truss can be edited like a closed polyline. This is not always recommended, though, because the truss may no longer match the space in the structure that it is meant to occupy. See [Editing Truss Envelopes on page 900](#).

The depth of truss chords can be changed in the truss's specification dialog, but not using the edit handles.

## USING THE EDIT TOOLS

A selected truss can be edited in a variety of ways using the buttons on the Edit Toolbar. See [The Edit Toolbar on page 130](#).



**Build Framing for Selected Object(s)** rebuilds the envelope and webbing of the selected truss. See [Editing Truss Envelopes on page 900](#).



**Move to Framing Reference** moves the selection into alignment with a Framing Reference Marker. See [Framing Reference Markers on page 875](#).



**Open Truss Detail** opens the Truss Detail with the selected truss centered in the view. See [Displaying Trusses on page 897](#).

## USING DIMENSIONS





Trusses can be repositioned precisely as well as resized using dimensions. See [Moving Objects Using Dimensions on page 483](#).

In order for a dimension tool to locate trusses as dimensions are drawn, that tool needs to be set to do so in the Dimension Defaults dialog. See [Locate Manual Panel on page 454](#).

## MOVING TRUSSES

Trusses can be moved using either their Move edit handle or the **Transform/Replicate Object**  edit tool. It's important to note that Roof and Floor/Ceiling Trusses may behave differently when they are moved:

- When a **Roof Truss**  is moved, its shape updates to conform to the structural conditions defined by the roof and ceiling in its new location. To prevent this from occurring, check **Lock Truss Envelope and Webbing** in the Roof Truss Specification dialog before moving the truss. See [Lock Truss Envelope and Webbing on page 901](#).
- This is not the case with **Floor/Ceiling Trusses** : when moved to a location with a different platform structure, a Floor/Ceiling Truss will not update to conform to its new surroundings. It is important to draw, position, and copy them within the same floor or ceiling platform structure. If a different Floor/Ceiling Truss depth is needed, a new truss should be drawn.

## SPECIAL TRUSS SNAPPING

By default, **Roof Trusses**  have a number of special snapping behaviors that are used even when **Object Snaps**  are toggled off. See [Object Snaps on page 160](#).

These special behaviors include:

- As they are drawn, Roof Trusses will snap to any walls that they cross.
- When drawn along an exterior wall, a Roof Truss will snap so that its outer surface is flush with the outer surface of the wall's Main Layer.
- When drawn along a roof plane edge, a Roof Truss will snap to the roof plane's edge or corner.
- The center line Roof Trusses will snap to the line along which two roof planes meet.
- When a Roof Truss ends over an exterior wall, it will extend into the roof eave, stopping at the inside edge of the Eave Sub Fascia.

**Floor/Ceiling Trusses**  can be drawn to any length but also have special snapping:

- Floor/Ceiling trusses will snap to the wall surfaces, the exterior surface of a wall's Main Layer, as well as to a variety of CAD-based objects.

If you edit a truss in such a way that its ends do not correspond to a special snapping location, **Use Special Snapping** will automatically become unchecked in its specification dialog. This allows you to easily customize a truss but may make it difficult to snap to commonly used locations.

You can check or uncheck **Use Special Snapping** in the Roof Truss Specification dialog. See [General Panel on page 912](#).

## DELETING TRUSSES



Individual and group-selected trusses can be deleted the way other objects in the program can. See [Deleting Objects on page 284](#).



Trusses can also be deleted by category as well as floor in the Delete Objects dialog. See [Delete Objects Dialog on page 285](#).

You can also delete all instances of a particular truss by deleting its representation from the Truss Detail. See [Truss Details on page 901](#).

---

## Editing Truss Envelopes

A truss envelope is the shape defined by a truss's top and bottom chords. When a truss is drawn, the envelope is derived from the floor platform, ceiling platform, or roof that the truss is drawn in.

When a truss is viewed in a 3D view, its envelope can be edited like a closed polyline. See [Editing Closed Polyline-Based Objects on page 228](#).

This function can be used to change a roof truss end or overhang as well as the overall truss shape. Changing the truss envelope does not change the structure that it is drawn in, however.

In addition, when a **Roof Truss**  is moved, its shape updates to conform to the structural conditions defined by the roof and ceiling in its new location. As a result, a Roof Truss's label can change when the truss is moved to a new location.

**Floor/Ceiling Trusses**  do not update when moved to a location with different structural conditions.

## FORCE TRUSS REBUILD



If you make changes to a selected truss that affect its envelope or webbing, click the **Build Framing for Selected Object(s)** edit button to ensure that its configuration is up-to-date. You can also achieve this by checking **Force Truss Rebuild** in the truss's specification dialog. See [General Panel on page 912](#).

## LOCK TRUSS ENVELOPE AND WEBBING

The **Lock Truss Envelope and Webbing** attribute can be used to prevent a **Roof Truss**  envelope from updating when it is moved or replicated. See *Roof Truss Specification Dialog on page 912*.

---

## Truss Details



A Truss Detail is a special CAD Detail window in which a diagram of each truss configuration present in the plan is drawn. To open a plan's Truss Detail, select **CAD > CAD Detail Management** . See *CAD Details on page 337*.



You can also select a Floor/Ceiling or Roof Truss and click the **Open Truss Detail** edit button. The Truss Detail will open centered on the selected truss.

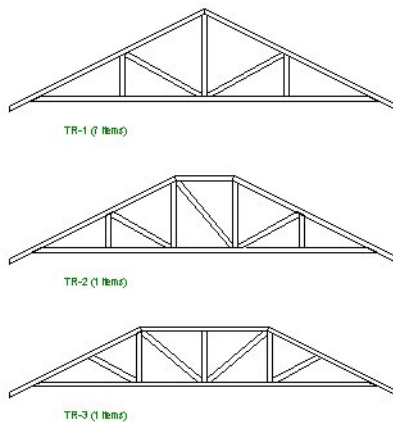

A Truss Detail is created automatically when a truss is created, and displays all trusses present in the current plan. If multiple trusses are identical, they share a single diagram. Each truss's label displays centered below the truss diagram. When automatic or custom labels are in use, the quantity of each truss configuration is also listed. See *Truss Labels on page 902*.

In a Truss Detail, individual chords and webbing are represented using framing members. The truss label information is presented in a Text object.

The trusses in a Truss Detail are linked to the actual trusses in the plan. If you move a truss in a Truss Detail, it will move in the model as well. Similarly, if you delete a truss from the Truss Detail, all instances of that truss will also be deleted from the model.

To modify the information in a Truss Detail without affecting the model, use **CAD Detail From View**  to create a line-drawn copy first. See *CAD Detail from View on page 338*.

To locate a selected truss in plan view, click the **Find Trusses**  edit button.

Note: The Truss Detail is for display of trusses only. Editing the members that make up the trusses in the Truss Detail is possible but not recommended.

### ***To restore an edited Truss Detail diagram***

1. Delete any new members you have drawn in the detail view.
2. In plan view, select the truss and click the **Open Object**  edit button to open the Roof Truss Specification dialog.
3. Check **Force Truss Rebuild** and click **OK** and the truss regenerates along with its Truss Detail diagram.

---

## **Truss Labels**

Labels for roof trusses display when the “Framing, Roof Truss Labels” layer is turned on in the current view. Similarly, floor and ceiling trusses display when the “Framing, Floor/Ceiling Truss Labels” is turned on. See [Layer Display Options Dialog on page 179](#).

Truss labels are available in three formats: automatic, user-specified, and schedule callouts. See [Label Panel on page 700](#).

Truss labels can display in plan view, cross section/elevation views, and the Truss Detail. Automatic and user-specified labels are used in the Label column of the Materials List. See [Displaying Trusses on page 897](#).

Truss labels use the Text Style specified for their layer in the current view. See [Text Styles on page 538](#).

By default, truss labels are centered on the truss that they identify. If the truss is moved or deleted, the label is moved or deleted as well. With the exception of those in the Truss Detail, truss labels have their own Move and Rotate edit handles which display when the truss is selected. See [Editing Trusses on page 898](#).

Truss labels obey the **Minimum Display Size** for labels set in the Preferences dialog. See [Appearance Panel on page 95](#).

If two or more trusses share the same configuration with identical chords and webbing, they will also share the same truss label. In the Truss Detail, automatic and user-specified labels shared by multiple trusses will be followed by the total number of those trusses, in parentheses.

### **AUTOMATIC TRUSS LABELS**

Automatic roof truss labels use the format TR-X, where X is a number indicating the order in which each distinct truss configuration was created. For example, the first truss type created in a plan is labeled TR-1; the second, TR-2; and so on.

Floor and ceiling trusses are labeled FTR-X and use the same numbering convention.

---

## **Mixing Trusses with Stick Framing**

After the trusses for your roof are in place, additional roof framing can be added. See [Roof Framing on page 853](#).

### **FRAMING DEFAULTS**

Roof planes created using defaults set up for trusses will continue to use those defaults when stick framing is added. If you intend to add rafters, the roof planes should be created while **Trusses (no Birdsmouth)** is unchecked in the Build Roof dialog. See [Roof Panel on page 798](#).

Leaving **Trusses (no Birdsmouth)** unchecked has a similar effect on roof trusses to that of **Raise Off Plate**: roof truss bottom chords may be longer than expected and their top chords, higher. This is necessary to create the space needed to accommodate the rafter’s depth.

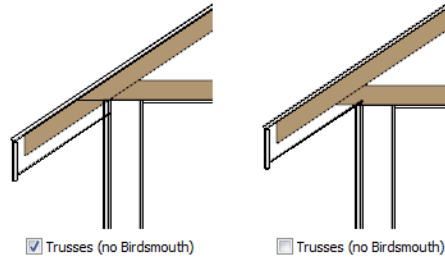

## AUTOMATIC FRAMING

The Build Framing dialog can be used to generate roof framing in areas not framed by the trusses, including gable eaves and the ends of hips. Note that rafters will not generate closer than 14” (350mm) to an existing, parallel truss.

Automatically generated roof framing will not extend through an existing roof truss. Instead:

- Automatically produced rafters generate inward from the eave until they butt into a truss.
- Blocking for standard and hip ridges generates as individual rafter objects between trusses.
- Lookouts will pass over **Reduced Gable** trusses and will end at the next truss in. See *Roof Truss Specification Dialog on page 912*.
- Hip ridges and common rafters at the end of a hip roof will pass over a **Drop Hip Truss**. See *Drop Hip or California Hip on page 908*.

## MANUALLY DRAWN FRAMING

Unlike automatically generated roof framing, manually drawn rafters will extend through trusses. Rafters can also snap to truss edges as they are being drawn or when they are being edited. See *Manual Framing on page 854*.

---

# Truss Bases

 A **Truss Base** is a closed polyline that defines the area in which valley fill roof trusses are to be built across and above the tops of normal, full size roof trusses.

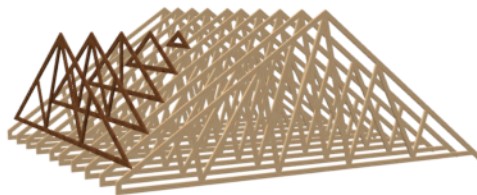

Valley fill trusses are often used in reverse gable conditions, where a roof ridge builds onto a roof plane that has a ridge running at a different angle. A classic example of this is an “L” shaped house with a gable roof. The main portion of the house is trussed through from end to end with normal trusses. Starting at its outside end, the smaller wing is trussed with normal trusses until the main house is reached. Where the wing’s roof builds over the main house, valley fill trusses are used.

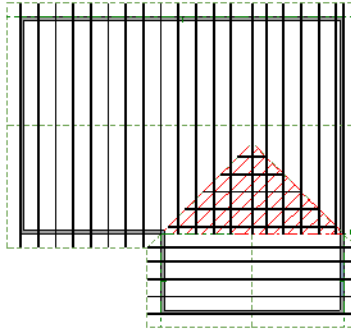

Normal roof trusses are built between roof planes and ceiling planes. See *Roof Trusses on page 895*. Valley fill roof trusses created using a Truss Base, on the other hand, are built between a larger, supporting roof plane below and overbuilt roof planes above.

Truss bases are drawn and can be edited much like roof planes, with some limitations. See *Truss Base Specification Dialog on page 907*.

To work correctly, a truss base must be in the same plane with the underlying roof plane, so their baselines should be collinear.

***To create a truss base***

1. Create an L-shaped house with a reverse gable roof.

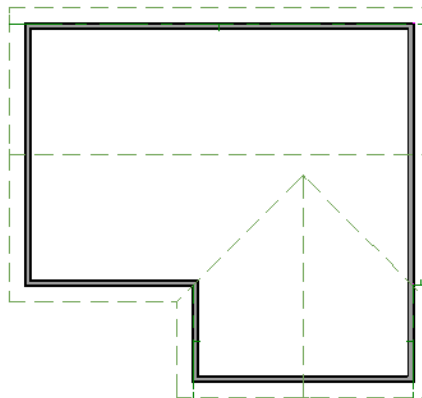

The triangular area of overlap between the main roof and the gable must be defined as a Truss Base.

2. Select **Build> Roof> Truss Base** , then draw a baseline that is collinear with the baseline of the roof plane that will support the overbuild. See *The Baseline on page 805*.



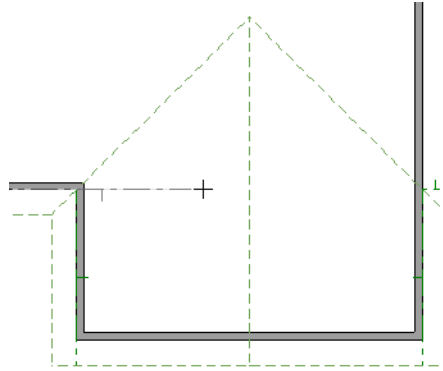

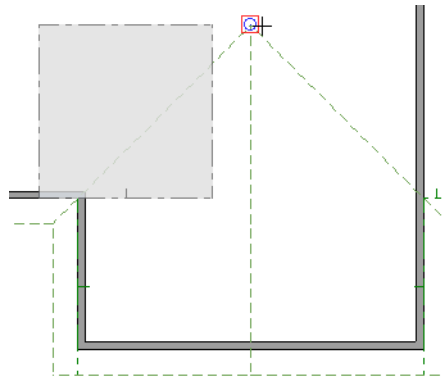

3. Move the pointer and click on the point where the gable intersects the main roof.

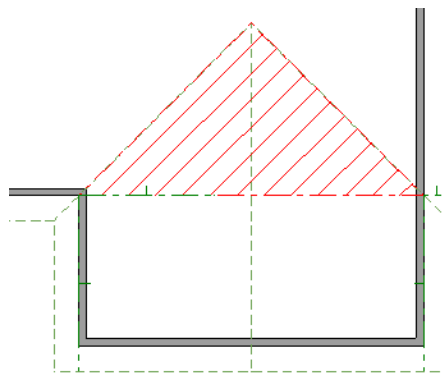

4. A rectangular Truss Base is created. Use its edit handles to reposition it and change its shape as needed.

- The two angled sides should be collinear with the roof valleys.
- The straight bottom edge must remain collinear with the Truss Base baseline and that of the underlying roof plane.



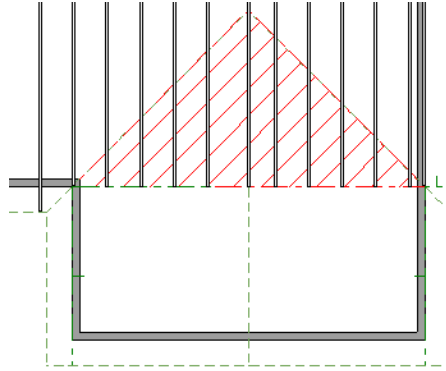

5. Draw the normal **Roof Trusses**  across the length of the main portion of the house. See [Roof Trusses on page 895](#).

- The trusses of the underlying roof generate through the Truss Base, but stop at the Truss Base's bottom edge so that no overhang is produced in that area.

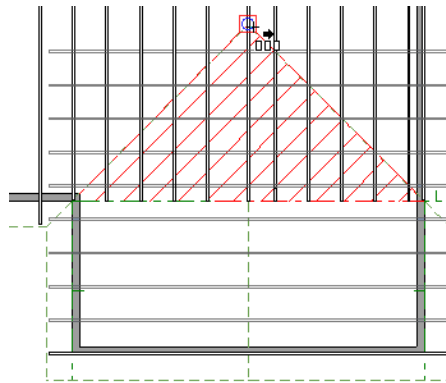

6. When the trusses of the underlying roof are in place, draw the first truss of the reverse gable and position it over the outer wall.
7. With this truss selected, click the **Multiple Copy**  edit button and drag the Move edit handle up to the peak of the Truss Base.
  - Copies of the truss appear as you drag the pointer.
  - The truss copies all appear to be full length until you release the mouse.



 Trusses drawn perpendicular to the baseline of a Truss Base go under the Truss Base. Trusses drawn parallel to the baseline of the Truss Base become valley fill trusses drawn over it.

8. When you release the mouse button, any copies drawn in the Truss Base are clipped by it.

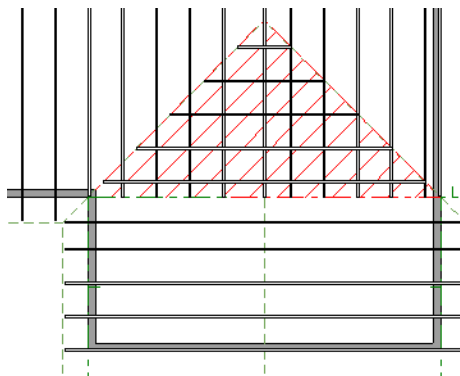

## EDITING TRUSS BASES

A selected truss base can be edited in plan view using edit handles, edit toolbar buttons, and the Truss Base Specification dialog.

Truss bases can be edited much the way roof planes can, with some limitations. They are not actual 3D objects, so they cannot be assigned materials, moldings or other design attributes; however, their shape, height, pitch and display can be edited. See *Editing Roof and Ceiling Planes on page 808*.

---

## Truss Base Specification Dialog

Select a truss base and click the **Open Object** edit button to open the Truss Base Specification dialog. See *Truss Bases on page 903*.

This dialog is almost identical to the Roof Plane Specification dialog. Although truss bases are not the same as roof planes, Chief Architect handles the positioning of the two in a similar manner.

### GENERAL PANEL

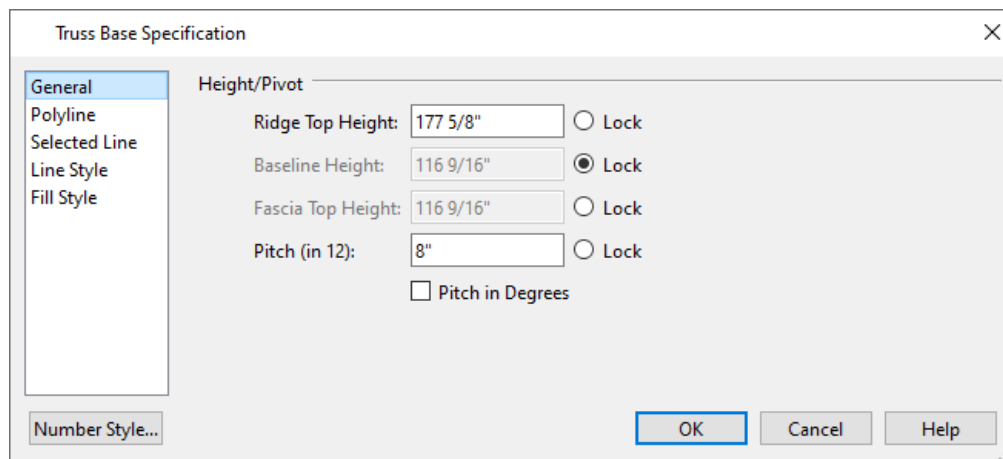

Four values define 3D orientation of a truss base: Ridge/Top Height, Baseline Height, Fascia Top Height, and Pitch. These values are related; if one is changed, the others change as well.

These values are measured from the first floor elevation of 0' 0". Baseline Height and Pitch should be set identical to those of the roof plane that surrounds the truss base.

Click the radio button to the right of a value to define it as the pivot point for the truss base and prevent it from being changed.

Changing these values does not affect the 2D representation of the truss base.

Specify the **Height/Pivot** of the selected truss base.

- Specify the **Ridge/Top** height, which is the truss base's highest point.
- Specify the **Baseline** height.
- Specify the **Fascia top** height, which is the truss base's lowest point. Usually, this is the same height as the Baseline.
- Specify the **Pitch** of the selected truss base. If you lock the pitch and change one of the Height values, the truss base moves vertically keeping the same slope.
- Check **Pitch in Degrees** to display the Pitch value in degrees rather than run-and-rise units.

## POLYLINE PANEL

The POLYLINE panel states the length of the truss base's **Perimeter** and its enclosed **Area**. Truss bases have no thickness, so they do not have a **Volume**. See *Polyline Panel on page 317*.

## SELECTED LINE PANEL

For information about the SELECTED LINE panel, see *Line Panel on page 304*.

## LINE STYLE PANEL

The settings on the LINE STYLE panel affect the appearance of the selected Truss Base in plan view. For information about these settings, see *Line Style Panel on page 305*.

## FILL STYLE PANEL

The settings on the FILL STYLE panel affect the appearance of the selected Truss Base in plan view. For information about the settings on this panel, see *Fill Style Panel and Dialogs on page 193*.

---







# Hip Trusses

A variety of different hip truss configurations can be created, including:

## STEP DOWN HIP

Step Down hip roofs are the quickest style of hip truss framing to produce.

### *To create a step down hip truss system*

1. First, draw a **Roof Truss**  at the apex of the triangular hip roof plane. When **Object Snaps**  are enabled, it will snap into position. See *Object Snaps on page 160*.
2. Select the truss; click the **Multiple Copy**  edit button; and click and drag the Move handle down into the hip to create copies at regular intervals. See *To replicate trusses using Multiple Copy on page 897*.
3. Stop when the height of the hip truss reaches a reasonable minimum.
4. Using the **Roof Truss**  tool, draw hip jacks along the hip ridge from the last truss out into the overhang.
5. Using the **Roof Truss**  tool, draw a jack truss from the intersection of the last hip truss and the hip jack to the eave.
6. Select the jack truss; click the **Multiple Copy**  edit button; and lay out jack trusses up to the other hip jack.

## DROP HIP OR CALIFORNIA HIP

A Drop Hip, or California Hip, system uses trusses with lowered top chords to support stick frame hip ridges and common rafters.

### ***To create a drop hip truss system***

1. Start a drop hip truss system as you would a step down hip system. See [Step Down Hip on page 908](#).
2. When the hip trusses are drawn, group select them, open the Truss Specification dialog, and select the **Drop Hip Truss** check box. See [General Panel on page 912](#).
3. Use the Build Framing dialog to produce the common rafters, and the short joists at the hip end. See [Build Framing Dialog on page 860](#).



The amount that the top chord is lowered is derived from the rafter **Depth** on the ROOF panel of the Framing Defaults dialog. Because both common rafters and hip ridges must pass over this truss, the ridge depth should be set equal to that of the rafter depth.

### **SUBGIRDER HIP**

Sub-girders are the partial trusses that butt into a reinforced girder truss at the end of the main run. Girder trusses and sub-girders can be generated automatically, and you can specify the girder count as well as its distance from the end wall. See [Roof Panel on page 869](#).

Girder trusses and subgirders can also be drawn manually.

### ***To create a subgirder truss system manually***

1. Draw a **Roof Truss**  and position it as needed: for example, where the hip apex meets the ridge.
2. Double it by drawing a second truss on the far side from the hip section.
3. Using the **Roof Truss**  tool, draw the first subgirder from the hip apex out to the eaves.
4. Select it and use the **Multiple Copy**  edit button to make copies in both directions. Stop when the height of the subgirders reach a reasonable minimum.
5. Finish off with hip jacks and jack trusses as in a step down hip system.

---

## **Special Roof Trusses**

A number of special purpose roof trusses can be created in Chief Architect.

### **ENERGY HEELS**

An energy heel or raised heel truss is created when the roof is raised off of the wall top plates, creating space for additional insulation. When this is the case, a vertical member positioned over the supporting exterior wall is added to the truss.

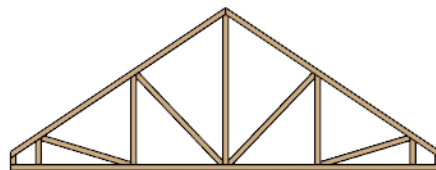

Energy Heel Truss

### ***To create an energy heel***

1. In the Build Roof dialog:
  - Specify the **Framing Type** as **Trusses**;
  - Specify the desired **Heel Height**;
2. Automatically generate or manually draw the roof planes.
3. Automatically generate roof framing or manually draw Roof Trusses. See *To draw and replicate trusses on page 897*.
4. By default, the bottom chord extends out to the subfascia. If a truss is moved or replicated into a position where an Energy Heel is required, open the truss's specification dialog, check **Energy Heel** and **Force Truss Rebuild**, then click **OK**. See *General Panel on page 912*.

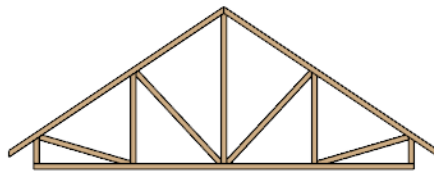

Energy Heel Truss with shortened bottom chord

5. Use the **Multiple Copy**  edit tool to make additional copies of that truss as needed.

### **ATTIC TRUSSES**

Attic trusses, a variation of roof trusses, can be drawn if a plan contains an Attic area on both sides and above an upstairs room, such as in a Cape Cod style home. The following is a typical cross section view of a building with attic trusses:

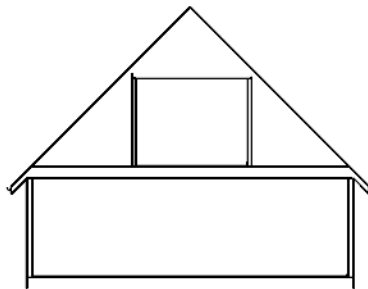

Structure that meets requirements for Attic Trusses

Certain conditions must be met before an attic truss can be built:

- The structure should be sufficiently wide to allow for a loft and attic spaces.
- The loft area must be on a living floor. It cannot be on the Attic floor. See *The Attic Floor on page 738*.
- The loft area must have Attic rooms on both sides. See *Room Types and Functions on page 415*.
- The loft area must be separated from the Attic rooms on both sides by Knee Walls. See *Knee Walls on page 380*.
- A flat ceiling in the loft area and a floor below must be present.
- The roof pitch must be steep enough to provide appropriate ceiling height for the loft area. Typical pitches for such a condition are 8 in 12 or greater.
- The roof should bear on the walls of the floor below the loft area and form continuous planes from ridge to baselines.

Once these conditions are met, a roof truss is ready to be designated as an attic truss.

1. Select the roof truss in plan view and click the **Open Object**  edit button to display the GENERAL panel of the Roof Truss Specification dialog.
2. Check the box beside **Attic Truss** and click OK. See *Roof Truss Specification Dialog on page 912*.

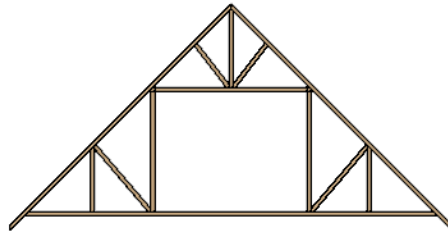

Attic Truss

The final product can be viewed in a framing overview or in the Truss Detail. See *Truss Details on page 901*.

## SCISSORS TRUSSES

Trusses drawn between roof planes and sloping ceiling planes of a different pitch than the roof are called Scissor trusses. See *Ceiling Planes on page 826*.

The following is an example of a scissors truss drawn beneath an 8 in 12 pitch gable roof and above 4 in 12 pitch ceiling planes.

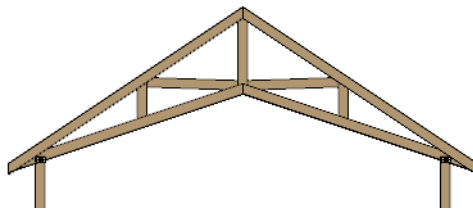

Scissor Truss

## GIRDER TRUSSES

Girder trusses provide extra support for various purposes. Hip end girder trusses consisting of two or more trusses side by side can be generated automatically. See *Hip Trusses on page 908*.

Other types of girder trusses can be drawn manually.

Draw a new truss from an existing truss to the roof edge, as you would to draw a hip or end jack truss; or draw a truss between two trusses, forming a girder. This may be necessary for a large opening, such as a skylight.

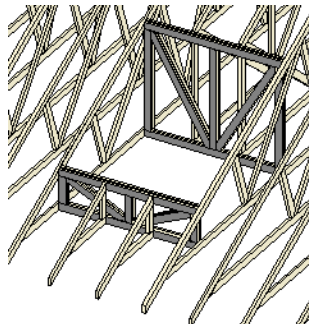

Girder Trusses reinforcing a skylight hole

Trusses cannot be drawn through each other. If a truss is drawn through an existing truss, the program automatically shortens it so that it butts into the existing truss.

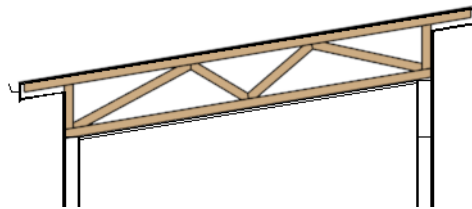

### SLOPING FLAT TRUSSES

A sloping flat truss is a roof truss that builds within the structural layer of the roof plane(s) it is drawn in. In order to create one, the roof plane(s) must have a structural layer deep enough to accommodate its chords and webbing.



Sloping Flat Truss

#### *To create a sloping flat truss*

1. Select the roof plane in which you would like to draw sloping flat trusses and click the **Open Object**  edit button.
2. On the STRUCTURE panel of the Roof Plane Specification dialog, specify the roof **Structure** depth as the desired depth of the sloping flat truss. See [Structure Panel on page 817](#).
3. Select the roof truss and click the **Open Object**  edit button.
4. On the GENERAL panel of the Roof Truss Specification dialog, check the boxes beside **Sloping Flat Truss** and **Force Truss Rebuild**, then click OK. See [General Panel on page 912](#).
5. Use the **Multiple Copy**  edit tool to replicate the truss within the area of the roof plane(s) edited in step 2.

---

## Roof Truss Specification Dialog

 Select a roof truss or group of roof trusses and click the **Open Object** edit button to open the Roof Truss Specification dialog.

The Roof Truss Specification dialog allows you to redefine parts of an existing truss or group of trusses. Some settings affect only individual trusses, such as gable trusses, while others affect the whole group.

The shape or volume of a roof truss is controlled by the roof planes above it and the ceiling planes below it. It cannot be changed from this dialog.



Truss webbing is drawn for representational purposes only and as with trusses in Chief Architect in general, is not engineered.

The Roof Truss Specification dialog has the following panels:

### GENERAL PANEL

The defaults for many of the settings on the GENERAL panel are set in the Build Framing dialog. See [Trusses Panel on page 872](#).



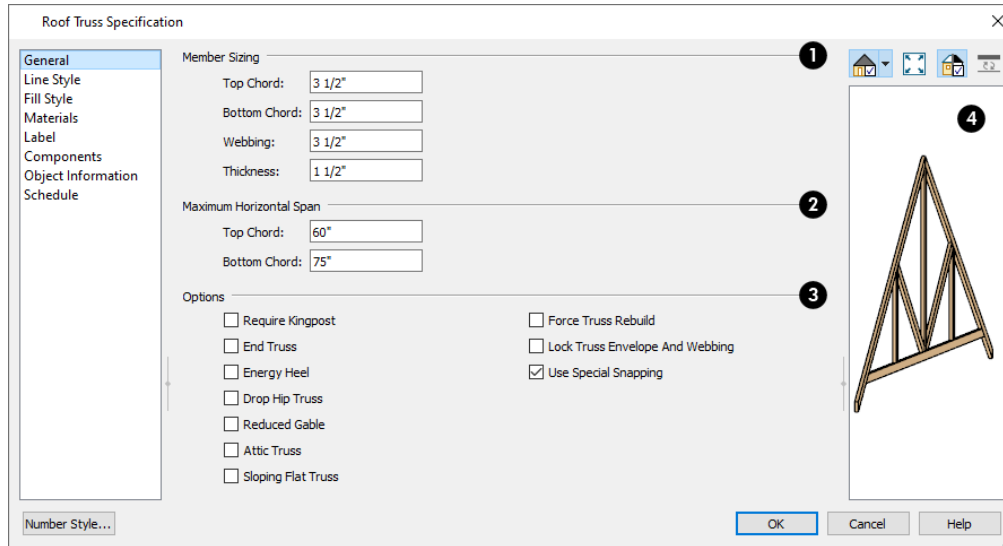

### 1 Member Sizing

Specify the sizes of the different members that form the selected truss.

- Specify the depths of the **Top Chord** and **Bottom Chord**.
- Specify the depth of the **Webbing**.
- Specify the **Thickness**, which is the width of the truss in plan view.

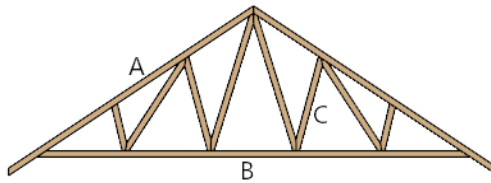

- A. Top Chord
- B. Webbing
- C. Bottom Chord

### 2 Maximum Span

Specify the **Maximum Span**, which is the maximum horizontal distance between supports along the **Top** and **Bottom Chords**. When these values are equal, the truss webbing often appears more regular.

### 3 Options

Additional **Options** allow you to create special truss types.

- Check **Require Kingpost** to require a vertical webbing member from the roof peak to the bottom chord.

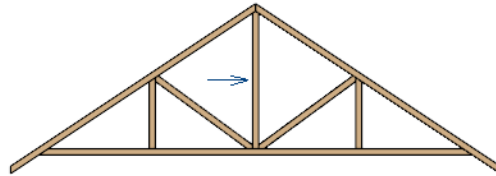

Roof Truss with Kingpost

- If Require Kingpost is unchecked, a kingpost may still be supplied, depending on the truss length and the specified maximum spans.
- Check **End Truss** to replace the webbing with vertical members positioned and spaced the same as the wall studs below.

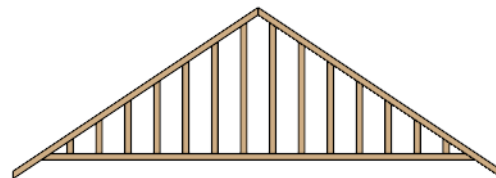

End Truss

- If an End Truss is in the same position as an Attic wall, it replaces the framing that would otherwise be produced for that wall when Include Automatic End Truss Above is checked in the specification dialog for the wall below. See [Roof Panel on page 398](#).
- Check **Energy Heel** to remove the bottom chord from the overhang area. For an energy heel to be modeled and for this setting to have an effect, the roof should also be raised off the top plates by at least 7", depending on the roof pitch. See [Energy Heels on page 909](#).

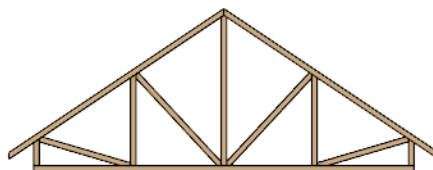

Energy Heel Truss with shortened bottom chord

- Check **Drop Hip Truss** to lower the flat top of a truss in the hip area of a roof so that common rafters and hip ridges can pass over and be supported by it. See [Drop Hip or California Hip on page 908](#).
- Check **Reduced Gable** to lower the top chord of an End Truss so that lookouts can pass over the truss. Reduced trusses do not have overhangs, but you can draw short rafters drawn at the ends of the truss.

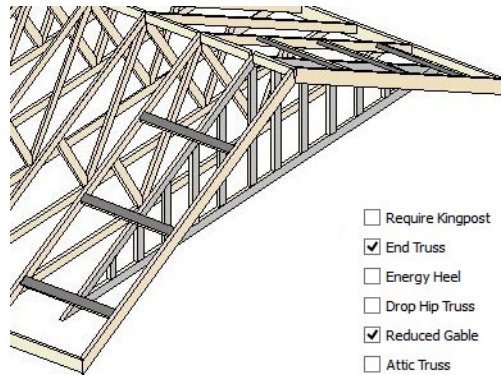

 The Insert End Truss in Attic Wall option in the Wall Specification dialog automatically produces a Reduced Gable End Truss above a selected wall. See [Structure Panel on page 395](#).

- Check **Attic Truss** to specify an attic truss. See [Attic Trusses on page 910](#).
- Check **Sloping Flat Truss** to create a truss with a bottom chord that follows the underside of the roof plane(s) it is drawn in. When this is unchecked, the bottom chord follows the ceiling of the room or manually drawn ceiling plane below. See [Sloping Flat Trusses on page 912](#).
- Check **Force Truss Rebuild** to rebuild the truss envelope based on the current state of the ceiling and roof when you click **OK**. See [Force Truss Rebuild on page 900](#).
- Check **Lock Truss Envelope and Webbing** to lock the size and configuration of the selected truss. If a locked truss is moved, it will maintain its original settings and will not fit properly if the new roof and ceiling conditions are different from the original. See [Lock Truss Envelope and Webbing on page 901](#).
- Uncheck **Use Special Snapping** to prevent the selected truss from using special truss snapping behavior. This box may become unchecked automatically if you edit a truss using its edit handles. When unchecked, **Object Snaps**  may still occur. See [Special Truss Snapping on page 899](#).

#### **4 Preview**

A preview of the selected truss displays on the right side of the panel. See [Dialog Preview Panes on page 22](#).

#### **LINE STYLE PANEL**

The settings on this panel affect the appearance of the selected truss in plan view only. See [Line Style Panel on page 305](#).

#### **FILL STYLE PANEL**

The settings on this panel affect the appearance of the selected truss in plan view. See [Fill Style Panel and Dialogs on page 193](#).

#### **MATERIALS PANEL**

The settings on the MATERIALS panel affect the appearance of the selected truss in 3D views. See [Materials Panel on page 1055](#).

## LABEL PANEL

Roof truss labels can display in plan view and cross section/elevation views when the “Framing, Roof Truss Labels” layer is turned on and use the Text Style assigned to that layer. See *Text Styles on page 538*.

Truss labels also display in the Truss Detail. See *Truss Details on page 901*.

For more information about the settings on this panel, see *Label Panel on page 700*.

Note: If a truss is listed in a schedule using callout labels, the settings here are overridden and the schedule label is used instead.

## COMPONENTS PANEL

The information on the COMPONENTS panel can be used in the materials list. For more information, see *Components Panel on page 1330*.

## OBJECT INFORMATION PANEL

The information entered on the OBJECT INFORMATION panel can be used in schedules and the materials list. For more information, see *Object Information Panel on page 1331*.

## SCHEDULE PANEL

The settings on the SCHEDULE panel determine which schedule categories the selected object is included in. See *Schedule Panel on page 704*.

---

# Floor/Ceiling Truss Specification Dialog

 To open the Floor or Ceiling Truss Specification dialog, select one or more floor or ceiling trusses and click the **Open Object** edit button. See *Floor and Ceiling Trusses on page 895*.

Default values for trusses are set in the Build Framing dialog. See *Build Framing Dialog on page 860*.

The Floor/Ceiling Truss Specification dialogs have the following panels:

## GENERAL PANEL

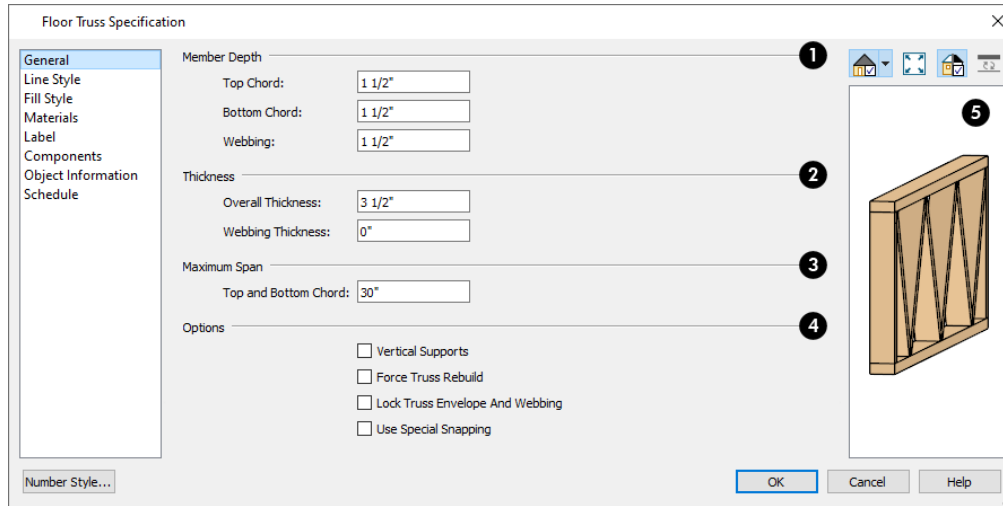

### 1 Member Depth

Specify the **Member Depth** of the different components of the selected truss.

- Specify the depth of the **Top Chord**.
- Specify the depth of the **Bottom Chord**.
- Specify the depth of the **Webbing**.

### 2 Thickness

Specify the **Thickness** of the truss's chords and webbing.

- Specify the **Overall Thickness** of the selected truss.
- Specify the thickness of the **Webbing**.

### 3 Maximum Span

Specify the **Maximum Span**, which is the maximum horizontal distance between supports along the **Top and Bottom Chord**.

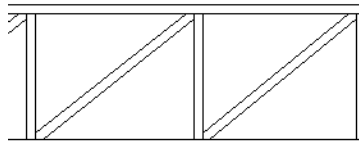

### 4 Options

- Check **Vertical Supports** to use vertical supports in the selected truss.
- Check **Force Truss Rebuild** to rebuild the truss envelope based on the existing floor or ceiling platform when you click OK. Not available if Lock Truss Envelope and Webbing is checked, below. See [Force Truss Rebuild on page 900](#).

- Check **Lock Truss Envelope and Webbing** to lock the size and configuration of the truss. A locked truss which has been relocated will maintain its original settings. See *Lock Truss Envelope and Webbing on page 901*.
- Uncheck **Use Special Snapping** to prevent the selected truss from snapping along its long edge to a wall's Main Layer or to the corner of a roof plane. If disabled, **Object Snaps**  may still occur. See *Special Truss Snapping on page 899*.

## 5 Preview

A preview of the selected truss displays on the right side of the panel. See *Dialog Preview Panes on page 22*.

## LINE STYLE PANEL

The settings on this panel affect the appearance of the selected truss in plan view only. See *Line Style Panel on page 305*.

## FILL STYLE PANEL

The settings on this panel affect the appearance of the selected truss in plan view only. See *Fill Style Panel and Dialogs on page 193*.

## MATERIALS PANEL

The settings on the MATERIALS panel affect the appearance of the selected truss in 3D views. See *Materials Panel on page 1055*.

## LABEL PANEL

Floor and ceiling truss labels can display in plan view and cross section/elevation views when the “Framing, Floor/Ceiling Truss Labels” layer is turned on and use the Text Style assigned to that layer. See *Text Styles on page 538*.

Truss labels also display in the Truss Detail. See *Truss Details on page 901*.

For more information about the settings on this panel, see *Label Panel on page 700*.

Note: If a truss is listed in a schedule using callout labels, the settings here are overridden and the schedule label is used instead.

## COMPONENTS PANEL

The information on the COMPONENTS panel can be used in the materials list. For more information, see *Components Panel on page 1330*.

## OBJECT INFORMATION PANEL

The information entered on the OBJECT INFORMATION panel can be used in schedules and the materials list. For more information, see *Object Information Panel on page 1331*.

## SCHEDULE PANEL

The settings on the SCHEDULE panel determine which schedule categories the selected object is included in. See *Schedule Panel on page 704*.

---

## Framing and Truss Schedules



The **Framing Schedule** tool allows you to produce customizable framing and truss schedules as well as object labels that display schedule numbers. See *Schedules and Object Labels on page 681*.

Framing schedules created in a Truss Detail use a special **Only Include Objects from this Detail** setting and a selection of Objects to Include that report only floor, ceiling, and roof trusses. See *Truss Details on page 901*.

# Trim and Moldings

## Chapter 26

Chief Architect offers a wide selection of trim and molding options. Corner boards, quoins, and frieze moldings can be added to a building’s exterior. Molding polylines and 3D molding polylines can be edited as 2D CAD objects using the CAD editing tools, then extruded to display in 3D for a variety of powerful applications.

In addition, Chief Architect offers a wide selection of trim and molding options for doors, windows, rooms, and many interior objects. See *The Library on page 945*.

You can also assign moldings to a variety of objects, such as rooms and cabinets, in those objects’ specification dialogs. See *Specification Dialogs on page 21*.

### TOPICS

<b>Trim and Molding Defaults</b> .....	<b>921</b>
<b>Corner Boards</b> .....	<b>921</b>
<b>Corner Board Specification Dialog</b> .....	<b>922</b>
<b>Quoins</b> .....	<b>923</b>
<b>Quoin Specification Dialog</b> .....	<b>923</b>
<b>Editing Corner Boards and Quoins</b> .....	<b>925</b>
<b>Moldings and Millwork</b> .....	<b>926</b>
<b>Moldings // Profiles / Rails / Panels</b> .....	<b>927</b>
<b>Molding Specification Dialog</b> .....	<b>931</b>
<b>Molding Profiles</b> .....	<b>932</b>
<b>Symbol Moldings</b> .....	<b>934</b>
<b>Molding Polylines</b> .....	<b>935</b>
<b>Displaying Molding Polylines</b> .....	<b>937</b>
<b>Editing Molding Polylines</b> .....	<b>937</b>
<b>Molding Polyline Specification Dialog</b> .....	<b>938</b>
<b>3D Molding Polyline Specification Dialog</b> .....	<b>939</b>
<b>Frieze Moldings</b> .....	<b>943</b>



---

## Trim and Molding Defaults



Select **Edit> Default Settings** to open the Default Settings dialog where you can access the defaults for a variety of drawing tools, including a number that affect trim and moldings.

- Click the + beside “Corner Trim” to access the defaults for Corner Boards and Quoins. See [Corner Boards on page 921](#) and [Quoins on page 923](#).
- Click the + beside “Floors and Rooms”, then beside “Floor Levels”. Select a floor level and click the **Edit** button to specify the default moldings for rooms on that floor. See [Floor Level Defaults on page 413](#).
- Click the + beside “Door” to access the defaults for Interior and Exterior Doors. See [Door Defaults on page 544](#).
- Select “Window” and click the **Edit** button to specify the default casing for windows. See [Window Defaults on page 577](#).
- Click the + beside “Cabinet” to access the defaults for the Cabinet Tools, where you can specify default crown and other moldings. See [Cabinet Defaults on page 618](#).

---

## Corner Boards



Corner boards are added to a building exterior in any view by selecting **Build> Trim> Corner Boards**.

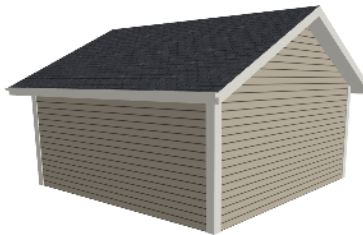

Click at a wall corner where you want to add trim. Be sure to click where the outside wall surfaces meet. If you click where the inside surfaces meet, corner trim will be created inside the room.

You can also add Corner Boards to all exterior corners at once by selecting **Build> Trim> Auto Place Corner Boards**

By default, **Auto Place Corner Boards**

 adds Corner Boards to outside corners only. If you prefer, you can specify that inside corners receive corner boards in the Corner Board Defaults dialog. See [General Panel on page 922](#).

Note: The Auto Place Corner Boards tool does not place corner boards on manually drawn dormers or at intersections with Attic Walls. See [Attic Walls on page 380](#).

Corner boards extend from the top plate down to the bottom of the floor platform of the floor on which it is placed, but do not extend to other floors. You must add corner boards to all floors of the building that you want to have corner boards.

A selected corner board or boards can be moved, but only to another wall corner or corners. In 3D views, corner boards can be lengthened or shortened using the edit handles. Corner boards can be copied, deleted and resized similar to other objects using the Edit Toolbar or the Corner Board Specification dialog. See [Corner Board Specification Dialog on page 922](#).

The default material for corner boards is defined by the **Exterior Trim** entry in the Material Defaults dialog. See [Material Defaults on page 1051](#).

## Corner Board Specification Dialog

Select one or more corner boards and click the **Open Object** edit button to open the Corner Board Specification dialog.

The settings in this dialog are similar to those in the Corner Board Defaults dialog, but affect the selected corner boards rather than all subsequently created corner boards.

### GENERAL PANEL

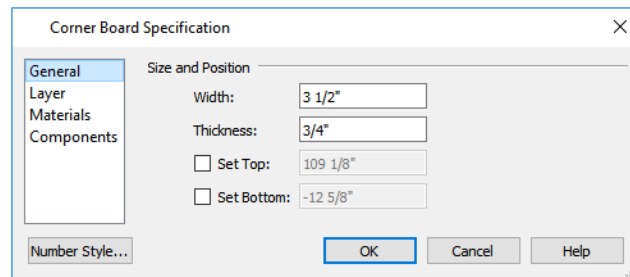

Specify the **Width** and **Thickness** of the selected corner board(s).

Check **Set Top/Set Bottom** to specify the top and bottom heights of the corner board(s).

- If **Set Top** is unchecked, the top of the corner board automatically extends to the top plate.
- If **Set Bottom** is unchecked, the bottom of the corner board automatically extends to the bottom of the floor platform.

In the Corner Board Defaults dialog, an additional **Auto Place Option** is available.

- Check **Include Inside Corners** to place Corner Boards on inside corners when the **Auto Place Corner Boards**  tool is used. When unchecked, only outside corners receive corner boards.

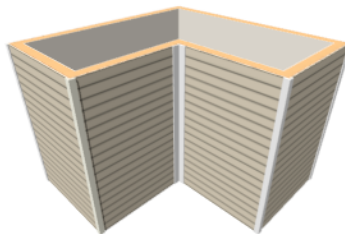

### LAYER PANEL

For information about the LAYER panel, see [Layer Panel on page 186](#).

### MATERIALS PANEL

The settings on the MATERIALS panel are available for a wide variety of objects in the program. For information about these settings, see [Materials Panel on page 1055](#).

### COMPONENTS PANEL

The information on the COMPONENTS panel can be used in the materials list. For more information, see [Components Panel on page 1330](#).

---

## Quoins



Select **Build> Trim> Quoins** in any view and click at a wall corner where you want to place quoins.

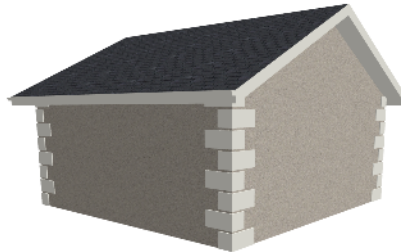

You can also add Quoins to all exterior corners at once by selecting **Build> Trim> Auto Place Quoins** .

By default, **Auto Place Quoins**  adds Quoins to outside corners only. If you prefer, you can specify that inside corners receive quoins in the Quoin Defaults dialog. See [General Panel on page 922](#).

Note: The Auto Place Quoins tool does not place quoins on manually drawn dormers or at intersections with Attic Walls. See [Attic Walls on page 380](#).

A selected quoin or quoins can be moved, but only to another wall corner or corners. In 3D views, quoins can be lengthened or shortened using the edit handles. Quoins can be copied, deleted and resized similar to other objects using the Edit Toolbar or the Quoin Specification dialog. See [Quoin Specification Dialog on page 923](#).

The size of quoins in plan view is relative on their size in 3D.

Initially, quoins use the same material as the default material of the wall surface they are placed against. This material is specified in the Wall Type Definitions dialog. See [Wall Specification Dialog on page 392](#).

---

## Quoin Specification Dialog



Select one or more quoins and click the **Open Object** edit button to open the Quoin Specification dialog.

The settings in this dialog are the same as those in the Quoin Defaults dialog, but affect the selected quoins rather than all subsequently created quoins.

## GENERAL PANEL

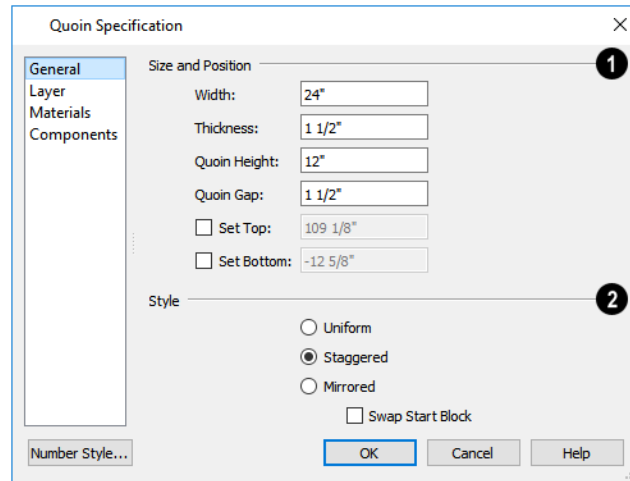

### 1 Size and Position

- Specify the **Width**, which is the horizontal dimension of each quoin in the selected Quoin object. The dimension along the other wall is half this value when they are staggered or mirrored.
- Specify the **Thickness**, which is the amount that the quoin protrudes from the exterior surface of the wall.
- Specify the **Quoin Height** for individual quoins in the selected Quoin object.
- Specify the **Quoin Gap**, which is the distance between successive quoins.
- Check **Set Top/Set Bottom** to specify the top and bottom heights of the quoin(s) in the text fields.
- If **Set Top** is unchecked, the top of the corner board automatically extends to the top plate.
- If **Set Bottom** is unchecked, the bottom of the quoin automatically extends to the bottom of the floor platform.

### 2 Style

- **Uniform** - Produce quoins that are of equal length on both sides of the corner.
- **Staggered** - Produce quoins that have one long side and one short side staggered on opposite sides of the corner.
- **Mirrored** - Produce quoins that alternate having either two long sides or two short sides.
- When Staggered or Mirrored is selected, check **Swap Start Block** to switch the starting order for the quoins.

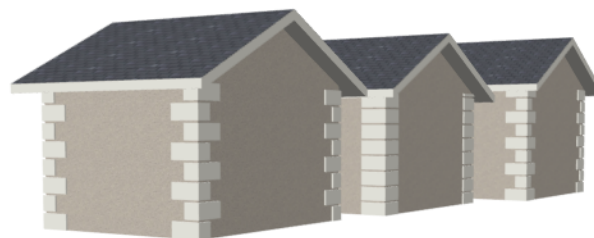

In the Quoin Defaults dialog, an additional **Auto Place Option** is available.

- Check **Include Inside Corners** to place Quoins on inside corners when the **Auto Place Quoins**  tool is used. When unchecked, only outside corners receive quoins.

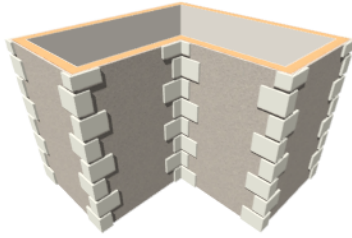

## LAYER PANEL

For information about the LAYER panel, see [Layer Panel on page 186](#).

## MATERIALS PANEL

The settings on the MATERIALS panel are available for a wide variety of objects in the program. For information about these settings, see [Materials Panel on page 1055](#).

## COMPONENTS PANEL

The information on the COMPONENTS panel can be used in the materials list. For more information, see [Components Panel on page 1330](#).

---

# Editing Corner Boards and Quoins

Before a corner board or quoin can be edited, it must be selected. Click on a trim object when the **Select Objects**  tool is active. Corner boards and quoins can also be group selected and edited. See [Selecting Objects on page 210](#).

Corner boards and quoins can be edited using their edit handles, the Edit Toolbar buttons, and their specification dialogs. See [Corner Board Specification Dialog on page 922](#) and [Quoin Specification Dialog on page 923](#).

## USING THE EDIT HANDLES

Depending on the type of view, a corner board or quoin displays a different set of edit handles when selected.

- In plan view, corner boards and quoins display one edit handle and can be moved from one eligible location at a wall corner to another.
- In 3D views, corner boards and quoins can be moved, lengthened, and shorted much the other line-based objects are. See [Editing Line-Based Objects on page 216](#).

## USING THE EDIT BUTTONS

A selected corner board or quoin can be edited in a variety of ways using the buttons on the Edit Toolbar. See [The Edit Toolbar on page 130](#).

## DELETING CORNER TRIM

Corner boards and quoins can be selected individually or in groups and deleted using the **Delete**  edit button or the Delete key on the keyboard. They can also be removed using the Delete Objects dialog. See [Deleting Objects on page 284](#).

---

# Moldings and Millwork

Moldings and millwork are often used to enhance both the interior and exterior of designs.

## MILLWORK

A selection of various types of millwork objects including columns, corbels and finials is available in the Library Browser. See [The Library Browser on page 946](#).

Most millwork objects are designed to be placed in a plan as free-standing objects. Some - notably, newels and balusters - can be assigned to objects such as railings and stairs. Other examples of millwork that can be assigned to objects include millwork on window exteriors and pilasters and feet on cabinets. See [Placing Library Objects on page 972](#).

Both free-standing millwork and that assigned to an object can be replaced from the library in 3D views. See [Replace From Library on page 976](#).

## MOLDINGS, RAILS, AND OTHER PROFILES

Molding profiles and symbols can be applied to a variety of different types of objects in Chief Architect, including rooms, doors, windows, cabinets, tray ceilings, and molding polylines. See [Assigned Items on page 974](#) and [Molding Profiles on page 932](#).



Moldings are assigned to their containing object in that object's specification dialog. See [Moldings // Profiles / Rails / Panels on page 927](#).

Moldings assigned to these objects can be listed in both the materials list and in schedules. See [Materials Lists on page 1303](#) and [The Schedule Tools on page 682](#).

A number of other objects, including roof planes, rope lights, railings, stairs, and ramps have features like ridge caps and handrails that are applied in a similar manner that moldings are applied to other objects.

## REPLACING AN EXISTING MOLDING

 If a molding profile or symbol has already been applied to an object, it can be replaced by another directly from the library in a 3D view. Select **Build > Trim > Replace Moldings**, select a molding profile or symbol from the Select Library Object dialog, then move the mouse pointer into the view window and click on a molding in the view. See [Select Library Object Dialog on page 974](#) and [Replace From Library on page 976](#).

You can also select a molding profile or symbol directly from the Library Browser while a 3D view is active and move your mouse pointer into the view window. When a molding is selected, the pointer displays the Moldings  icon. When the mouse pointer is moved over a molding in the view, the Replace From Library  icon displays instead. Click on the molding's surface to change its molding profile.

## Moldings / Profiles / Rails / Panels

The specification dialogs for a variety of objects in the program include a MOLDINGS panel. Select an object or group of similar objects and click the **Open Object** edit button to open the specification dialog for that selection. The settings available on this panel will vary depending on the type of object selected.

The RAILS panel of the Railing, Fencing, Staircase, Ramp, and Stair Landing Specification dialogs is similar to the MOLDINGS panel, as is the WALL CAPS panel of the Wall Specification dialog. See *Railing and Fencing Specification Dialogs on page 406* and *Staircase Specification Dialog on page 771*.

A number of roof attributes are also assigned the way moldings are. Rafter tails, ridge caps, gutters, frieze molding, and shadow boards are all created by specifying a profile and extruding it down a predetermined path. As a result, the settings on the RAFTER TAILS, RIDGE CAPS, GUTTER, FRIEZE, and SHADOW BOARDS panels function the same as those on the MOLDINGS panel. See *Build Roof Dialog on page 797*.

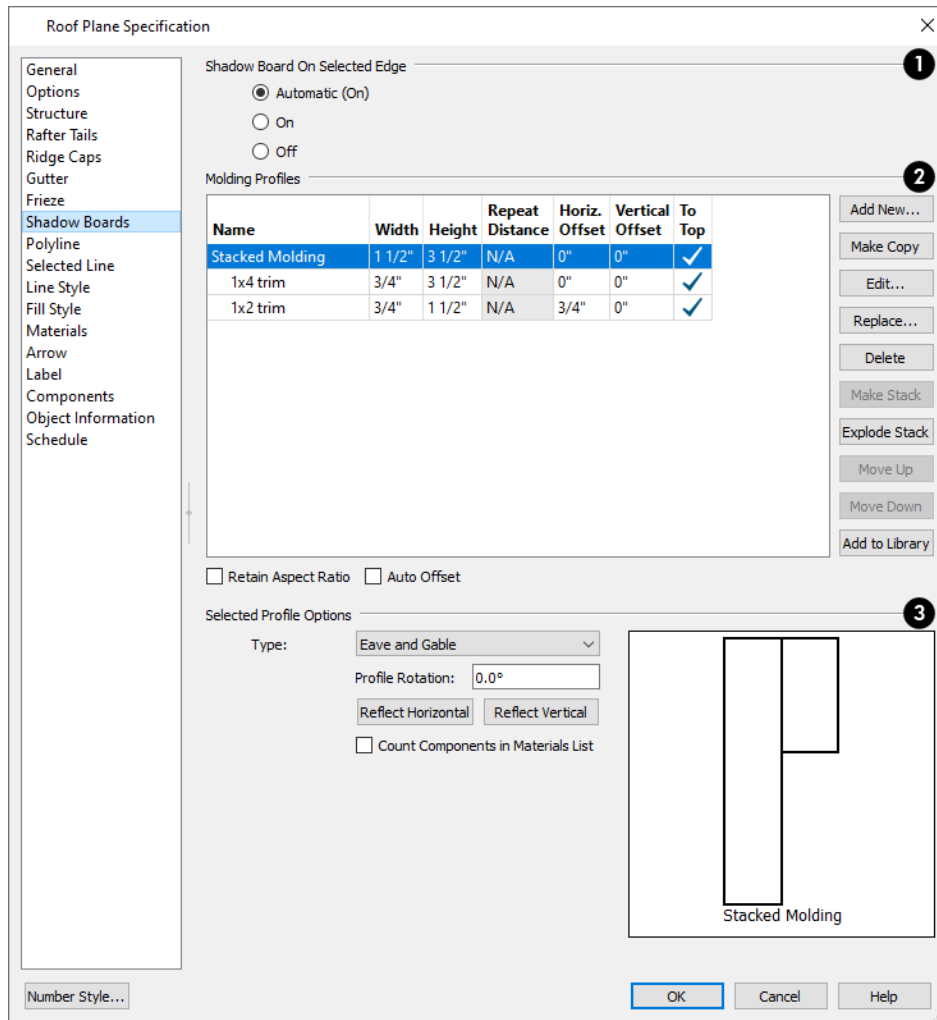

At the top of the dialog, one or more settings may be present.

- Only available for rooms, uncheck **Use Floor Default** to make the settings that follow active. Check this box to use the defaults set in the Floor Defaults dialog for the current floor. In the Room Type Defaults dialogs, the settings for Floor 1 are shown in the preview when this is checked. See *Floor Level Defaults on page 413*.
- If multiple objects with different moldings assigned to them are selected, a **No Change** check box will be available. Uncheck this box to make the settings that follow active but note that only moldings that all selected objects have in common will be retained.

Note: If multiple rooms are selected and only some of them have Use Default checked, these settings on this panel will not be editable.

- In the Tray Ceiling Specification dialog, specify the **Layer** that any Molding Polyline associated with the tray ceiling are assigned to. See *Layers on page 176*.

## 1 Selected Edge

The **On Selected Edge** settings are available on the RIDGE CAPS, GUTTERS, and SHADOW BOARDS panels of the Roof Plane Specification dialog when an individual roof plane is selected. They determine whether the profile(s) specified on the current panel generate along the selected roof plane edge. See *Roof Plane Specification Dialog on page 814* and *Selected Edge on page 212*.

Select **Automatic (On/Off)** to use the default behaviors for ridge caps, which generate on ridges and hips by default; gutters, which generate on eaves by default; and shadow boards, which generate on eaves and/or gables, as specified in the Build Roof dialog.

Select **On** to generate the profile in question on the selected roof plane edge whenever possible.

Select **Off** to suppress the profile in question on the selected roof plane edge regardless of its location.

## 2 Molding/Rail Profiles

The selected object's molding profiles, symbol molding(s), roof trim profiles, or rail profiles are listed in a table and can be edited here. Depending on the type of profile being edited, not all options will be available in the table.

On the RAILS panel of the Staircase, Ramp, and Stair Landing Specification dialogs, the table is divided into three sections: Top Rail, Middle Rail, Bottom Rail, and Beam.

- Select the name of a molding to edit it or remove it from the object.
- Click in the **Width** and/or **Height** column and type to specify the selected molding's size.
- When a Symbol Molding is selected, click in the **Repeat Distance** column and type the desired value. See *Symbol Moldings on page 934*.
- Specify the **Horizontal Offset**, which is how close the molding is to the perimeter of the selected object. Increase this value to create a gap between the selected object and the molding. See *Stacked and Recessed Moldings on page 933*.
- Specify the **Vertical Offset** of the selected molding, measured relative to the default molding location on the object it is assigned to.
- A check mark in the **To Top** column means that the Vertical Offset value is measured from the top of the molding. When unchecked, this value is measured from the bottom of the molding. Click to place or remove a check mark.



- Specify the distance that a selected rafter tail profile should **Extend** past the inside surface of the subfascia. This distance is measured along the top of the rafter tail, so it is greater than the length as measured in plan view.

Depending on the type of object selected, one or more check boxes will be found under the Molding Profiles table.

- When **Retain Aspect Ratio** is checked, if you change either the Height or Width, the other value changes to maintain their original ratio. When this is unchecked, the two values can be edited independently. This option also affects the Repeat Distance of a symbol molding, and is not available when Full Wall Width is checked, below.
- Check **Auto Offset** to have the program apply Horizontal and Vertical Offset values to the selected moldings based on their Widths and Heights.
- On the RAILS panel, check **Full Wall Width** to make the rail Width equal to the Thickness of the selected railing wall. Not available for stairs or ramps.
- On the WALL CAP panel of the Wall Specification dialog, when **Full Wall Width** is checked, the wall cap extends the width of the lower wall. When unchecked, it extends out from the exterior surface of the upper wall.
- Also on the WALL CAP panel, check **Split Pony Wall** to build a cap between the upper and lower walls, centered on the lower wall. This becomes checked automatically when Full Wall Width is checked, above.

The buttons on the right allow you to manage the moldings listed in the table.

- **Add New** opens the Select Library Object dialog and add a new molding profile or symbol to the selected object. See *Select Library Object Dialog on page 974*.
- Click the **Make Copy** button to add a copy of the selected molding profile, symbol, or stacked profile at the bottom of the list.
- Click the **Edit** button to customize the selected molding's Object Information and Schedule settings. See *Molding Specification Dialog on page 931*.
- **Replace** removes the selected profile, symbol, or stacked profile and replace it with a new profile or symbol from the Library.
- **Default** resets the Default Rail, Ridge Cap, Gutter, or Rope Light profile.
- Click the **Delete** button to remove the currently selected profile, symbol, or stacked profile from the table.
- **Make Stack** groups two or more selected profiles in the list profiles under a “Stacked Profile” line item. Changes made to a Stacked Profile affect all profiles in the stack. Not available for moldings with different To Top settings or different Types. See *Stacked and Recessed Moldings on page 933*.
- **Explode Stack** separates a selected stacked profile so they are no longer associated with one another.
- **Move Up** and **Move Down** change the order of the line items in the table. This does not change a selected item’s Height, Offset, To Top setting, or Type: only its position in the table.
- Click the **Add to Library** button to save a copy of the molding as specified here in the User Catalog. See *Adding Library Content on page 965*.

### 3 Selected Profile Options

The **Selected Profile Options** only apply to the molding profile or symbol selected above. The options available will vary depending on the type of object that is selected. See below.

- A preview of the molding profile(s) and/or symbol(s) displays here. When multiple moldings of the same Type, To Top setting, or similar Height are specified, they will display together here, even when only one is selected. The selected profile is identified by thicker edge lines than the others. When multiple moldings of different Types, To Top, or Height settings are selected, no preview will display.
- Specify the desired **Profile Rotation**. Not available for moldings in a stacked molding assembly or for molding symbols.
- Click the **Reflect Horizontal** button to reflect the selected profile from left to right, so its outward facing side becomes the profile's back.
- Click the **Reflect Vertical** button to flip the selected profile so its top becomes its bottom.
- When **Count Components in Materials List** is checked, the individual components of stacked profiles are counted separately in the Materials List. When unchecked, they are treated as a single profile. Only available when stacked profiles are specified above. See *Stacked and Recessed Moldings on page 933*.

### ***Cabinet Moldings and Counter Profiles***

- Select a molding **Type** from the drop-down list. For base cabinets, the choices are "Edge Profile" and "Base Molding"; for wall cabinets, "Crown Molding" and "Light Rail"; for full height cabinets, "Crown Molding" and "Base Molding". Cabinet molding Type is reported in schedules and the Materials List. When a molding's Type is changed, its To Top setting may also change, above. See *Materials Lists on page 1303*.
- Check **Offset Molding For Face Items** to measure the selected profile's Horizontal Offset from the cabinet's front, side, and/or back face items. When unchecked, the molding is offset from the cabinet box. See *Pilasters, Feet, and Moldings on page 638*.

### ***Room Moldings***

- Choose the currently selected molding's **Type** from the drop-down list: Base Molding, Chair Rail, or Crown Molding. When a molding's Type is changed, its To Top setting may also change, above. If no Type is selected, the molding will not be listed in the Room Finish Schedule. See *Room Moldings on page 436* and *Schedules and Object Labels on page 681*.

Note: The Default Base Molding is a basic rectangular stock profile rather than a profile from the library.

### ***Molding Polylines***

- When **Extrude Inside Polyline** is checked, the selected molding profile generates on the inside of the molding polyline. Uncheck this box to generate the profile on the exterior of the polyline instead. Only available for Molding Polylines and 3D Molding Polylines. See *Molding Polylines on page 935*.

### ***Roofs***

- On the FRIEZE MOLDING and SHADOW BOARDS panels, select a **Type** from the drop-down list: Eave and Gable, Eave only, and Gable only. See *Roof Returns and Other Details on page 844*.
- On the RAFTER TAILS panel, uncheck **Stretch to Fit Rafter** to use the rafter tail profile's default size or to specify its **Height** and **Width**, below. When this is checked, the profile is sized by the program to match the selected roof rafter.
- On the RIDGE CAPS panel, check **Bend to Roof Pitch** to adjust the shape of the selected ridge cap profile to match the pitch of the roof. This box should be unchecked if you are using a custom profile designed to follow a specific pitch or pitches.

### ***Walls and Railings***

- On the WALL CAP panel of the Wall Specification dialog, check **Extrude Inside Wall** to position a wall cap on the interior side of a pony wall instead of on the exterior side. See [Lower Pony Wall Caps on page 355](#).

### ***Framing***

- On the END PROFILE panel of the Framing Specification dialog for joists, beams, and General Framing, uncheck **Stretch to Fit Framing** to use the end profile's default size or to specify its **Height** and **Width**, below. When this is checked, the profile is sized by the program to match the selected framing member.

Many specification and defaults dialogs have previews of the selected object in which the moldings assigned to it can be seen. See [Dialog Preview Panes on page 22](#).

Some specification and defaults dialogs have previews of the selected object in which the moldings assigned to it can be seen. See [Dialog Preview Panes on page 22](#).

When **Use Floor Default** is checked in the Room Type Defaults dialog, this preview always shows the default moldings for Floor 1.

---

## **Molding Specification Dialog**

Right-click on a molding profile in the Library Browser and select **Open Object** from the contextual menu to open the Molding Specification dialog. When accessed in this manner, the item in the library can be edited but no moldings already present in any plans will be affected. See [Using the Contextual Menu on page 951](#).

You can also open this dialog by clicking the Edit button on the MOLDINGS panel of various object specification dialogs. When accessed in this manner, only the molding on the selected object is affected. See [Moldings // Profiles / Rails / Panels on page 927](#).

### **GENERAL PANEL**

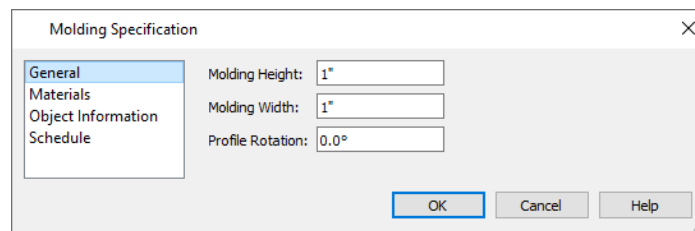

Specify the selected molding's **Height** and **Width**.

Specify the selected molding's **Rotation** in degrees, measured in a counterclockwise direction. Not available for symbol moldings.

### **MATERIALS PANEL**

The settings on the MATERIALS panel are available for a wide variety of objects in the program. For information about these settings, see [Materials Panel on page 1055](#).

If the selected molding is a stacked profile or molding symbol, multiple materials can be specified. See [Stacked and Recessed Moldings on page 933](#) and [Symbol Moldings on page 934](#).

## OBJECT INFORMATION PANEL

The information entered on the OBJECT INFORMATION panel can be used in schedules and the materials list. For more information, see [Object Information Panel on page 1331](#).

## SCHEDULE PANEL

The settings on the SCHEDULE panel determine which schedule categories the selected molding is included in. See [Schedule Panel on page 704](#).

---

# Molding Profiles

A molding profile is a representation of a 2D cross section of a particular style of molding created using one or more CAD polylines. A molding profile does not display in 3D on its own; it must be applied to an object like a room, a cabinet, or a molding polyline. See [Moldings // Profiles / Rails / Panels on page 927](#) and [Molding Polylines on page 935](#).

The library contains a selection of moldings, as well as curbs, gutters, handrails and rafter tails, which function much like molding profiles. You can customize library molding profiles and also create your own custom profiles and add them to the library. See [Adding Library Content on page 965](#).

## CREATING A MOLDING PROFILE

You can easily create custom molding profiles using the CAD drawing and edit tools by following a few basic guidelines.

- Draw a molding profile at its actual, unscaled size.
- The profile must be drawn with the proper orientation. The back of most profiles, or the side facing the wall, must be drawn as a vertical edge on the left side of the polyline.
- Similarly, curbs and gutters are drawn with the back of the profile as a vertical edge on the left side of the polyline.
- Open polylines should be used for gutter and rafter tail profiles. Gutter profiles attach to the roof on the left side, and rafter tail profiles should be open on the left side.
- Ridge cap profiles must be closed polylines and should have a bottom edge that is either horizontal or drawn so that it aligns with the surface of the roof at a particular pitch. In
- Rail, handrail, and railing beam profiles should be drawn with the bottom edge facing downward.



## ADDING MOLDING PROFILES TO THE LIBRARY

When a CAD polyline meets your needs as a molding profile, select it and click the **Add to Library**  edit button.

If you have drawn a molding profile using multiple closed polylines, select them as a group and click the **Add to Library as Stacked Molding**  edit button. A molding created in this manner can have more than one material assigned to it.

A molding that has been assigned to an object can also be added to the library by clicking the **Add to Library** button in the object's specification dialog. The Width and Height of the molding, as specified in the specification dialog, are retained; Offset values, however, are not. See *Moldings // Profiles / Rails / Panels on page 927*.

## EDITING A MOLDING PROFILE

Once created, the height, width, molding profile can be edited in a limited number of ways.

- Right-click on a molding profile in the Library Browser and select **Open Object**  from the contextual menu to open the Molding Specification dialog. See *Molding Specification Dialog on page 931*.
- The height, width, rotation, and material of a molding assigned to another object can also be edited in that object's specification dialog. See *Moldings // Profiles / Rails / Panels on page 927*.

There is not a way to edit the shape of an existing molding profile. You can, however, create a new profile either from scratch using the CAD tools or using the Place Molding Profile option.

## PLACE MOLDING PROFILE



An existing molding profile can be placed in plan view or a CAD Detail, edited, and added to the library as a new profile.

Right-click on a molding profile in the library and select **Place Molding Profile** from the contextual menu. Move your pointer into the drawing area and click once to place a closed CAD polyline identical to the selected profile at that location. The polyline can then be edited to suit your needs. See *Editing Closed Polyline-Based Objects on page 228*.

Note: Place Molding Profile cannot be used to apply a molding profile to an object - it is only used to place a profile polyline.

## STACKED AND RECESSED MOLDINGS

There are several ways to create stacked or built up moldings:

- Draw the entire build-up using a single polyline, then select it and click the **Add to Library**  edit button.
- Draw the build-up using multiple polylines, then select them as a group and click the **Add to Library as Stacked Molding**  edit button. A molding created in this manner can have more than one material assigned to it.
- Apply multiple moldings to an object, then specify their horizontal and vertical offsets, making sure they all have the same **To Top** setting. Finally, group-select the moldings and click the **Make Stack** button. Only room moldings of the same Type can be stacked in this manner. See *Moldings // Profiles / Rails / Panels on page 927*.

### *To build up molding profiles*

1. On the MOLDINGS panel of the specification dialog of any object that molding can be applied to, click the **Add New** button
2. Add a molding profile to the object and specify its **Height**, **Width**, and **Vertical** and **Horizontal Offset** values. Make a note of these values.
3. Click the **Add New** button and add a second molding profile to the object.
4. Specify the second molding profile's Height, Width and Offset values.
  - To define the **Vertical Offset**, add the first profile's Height and Vertical Offset values.
  - To define the **Horizontal Offset**, add the first profile's Width and Horizontal Offset values.

Similarly, molding can be recessed by specifying a negative Horizontal Offset - for example, to create an under cabinet light rail. See [Editing Cabinet Styles on page 636](#).

An alternative to molding profiles are symbol moldings. Molding symbols are different from molding profiles because they are replicated 3D symbols instead of extruded 2D shapes. See [Symbol Moldings on page 934](#).

---

## Symbol Moldings

Symbol Moldings are 3D symbols that are repeated along a path to form molding. Molding symbols are different from molding profiles because they are replicated 3D symbols instead of extruded 2D shapes.



### CREATING A SYMBOL MOLDING

Begin by opening a new, blank plan and creating a single instance of the molding symbol using the **Primitive Tools** .

See [Primitive Tools on page 1015](#). For example, to create the molding shown in the illustration above, make an object that looks like this:



When you are satisfied with its appearance, convert it to a 3D symbol. See [Convert to Symbol on page 1002](#).

You can also import a 3D symbol from another application. See [Importing 3D Symbols on page 998](#).

#### ***To import a molding symbol***

1. Select **File> Import> 3D Symbol**  from the menu. See [Import 3D Symbol Dialog on page 999](#).
2. In the Import 3D Symbol dialog, specify the symbol as Molding and click the **Advanced** button.
  - If you plan to use the molding symbol more than once, check the box beside **Add to Library**. See [Add to Library on page 965](#).
1. On the 3D panel of the Symbol Specification dialog, rotate the symbol as needed so that it faces you in the preview image.



Symbol moldings work best if you make them symmetrical.

Once created, a symbol molding can be assigned to an object or replicated along a molding polyline. See *Molding Polylines on page 935*.

Symbol moldings are center aligned. Both ends have a 45° miter, so the end instances may appear chopped. You can specify the **Repeat Distance** of a symbol molding applied to an object to control the width of each instance of the symbol on the object. See *Moldings // Profiles / Rails / Panels on page 927*.

## Molding Polylines

 A molding polyline is a 3D path that either a 2D molding profile is extruded along or a series of molding symbols is repeated along. Molding polylines can be used to create custom room moldings and decorations anywhere in your 3D model. The **Molding Polyline** tools are accessed by selecting **Build> Trim** from the menu.

There are four types of molding polylines:



**Molding Polylines**



**Molding Lines**



**3D Molding Polylines**



**3D Molding Lines**

To create a molding polyline, first select the desired **Molding Polyline** tool. The Select Library Object dialog will open. Select a molding profile or symbol from the library, then click and drag to draw the path for the selected molding profile or symbol.

If a molding profile or symbol has been previously selected during the current session in the program, you can begin drawing using this molding without selecting anything from the library.

Molding polylines can also be created using the **Make Room Molding Polyline** , **Make Cabinet Molding Polyline** , and **Convert Polyline**  edit tools.

### MOLDING POLYLINE



Select **Build> Trim> Molding Polyline** in plan view, a camera view or overview to create a rectangular molding polyline with a closed shape and a single height off the floor along its entire perimeter.

In plan view, Molding Polylines can also be created by selecting a profile from the Library Browser. Single-click to place a 2'x2' closed polyline or click and drag to draw a rectangular polyline.

### MOLDING LINE



Select **Build> Trim> Molding Line** in plan view, a camera view, or overview to create a molding line with a single height off the floor along its entire length. Multiple Molding Lines can be connected to form open or closed polylines as long as they share the same height.

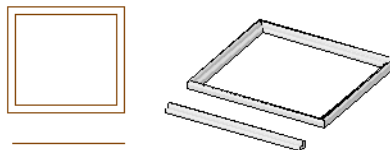

### 3D MOLDING POLYLINE

 Select **Build> Trim> 3D Molding Polyline** in floor plan or cross section/elevation view to create a closed molding polyline.

- When drawn in a cross section/elevation view, a 3D Molding Polyline's top and bottom edges have two different heights. Its sides have different heights at their start and end points.
- If drawn in plan view, a camera view, or an overview, a 3D Molding Polyline has a single height along its perimeter.

In either case, then lengths and angles of its edges can be edited in three dimensions. Although they are polyline-based objects, 3D Molding Polylines do not always have the same set of edit handles as other polylines. Depending on the angles of the various segments of a selected 3D Molding Polyline, which edge is selected, and the current view, some or all corner edit handles may not be available.

### 3D MOLDING LINE

 Select **Build> Trim> 3D Molding Line** in floor plan or cross section/elevation view to create a molding line.

- If drawn in a cross section/elevation view, a 3D Molding Line's start and end points can have two different heights.
- If drawn in plan view, a camera view, or an overview, a 3D Molding Line has a single height along its length.

3D Molding Lines can be connected to form polylines as long as the ends at which two segments connect have identical heights.

Once drawn, a 3D Molding Line can be edited so that it travels in three dimensions.

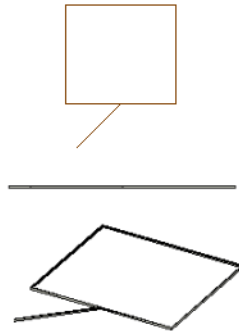

### MOLDINGS LIBRARY

In the plan view, select a molding profile from the library. The **Molding Polyline**  tool becomes active, allowing you to draw a molding polyline with using the selected profile.

### CONVERTING ROOM AND CABINET MOLDINGS

 Select a room and click the **Make Room Molding Polyline** edit button. This opens the Make Room Molding Polyline dialog, allowing you to select which type of room molding to convert to a molding polyline. See [Room Polylines on page 436](#).

 Select a cabinet and click the **Make Cabinet Molding Polyline** edit button. The Make Cabinet Molding Polyline dialog allows you to select a cabinet molding to convert to a molding polyline. See [Pilasters, Feet, and Moldings on page 638](#).



## CONVERTING A CAD POLYLINE



Select a CAD polyline and click the **Convert Polyline** edit button to convert it into either a Molding or 3D Molding Polyline. See [Convert Polyline on page 262](#).

---

## Displaying Molding Polylines



As with other objects, the display of molding polylines in 2D and 3D views is controlled in the Layer Display Options dialog. See [Layer Attributes on page 177](#).

There are a number of different types of molding polyline objects. By default:

- Molding polylines are placed on the “Moldings” layer.
- Roof ridge caps, gutters, frieze molding, and shadow boards are placed on the “Roofs, Ridge Caps”, “Roofs, Gutters”, and “Roofs, Trim” layers, respectively.

In plan view, manually drawn Molding and 3D Molding Polylines display as two sets of lines: one representing the molding’s front and one its back. The distance between them is determined by the Width of the molding profile. If a Horizontal offset is specified, that value is added to the distance between the two lines. See [Moldings // Profiles / Rails / Panels on page 927](#).

Molding Polylines are listed in the "Interior Trim" category of the Materials List by default and can also be included in schedules. See [Materials Lists on page 1303](#) and [The Schedule Tools on page 682](#).

## PROFILES ON THE SELECTED EDGE

By default, the molding(s) assigned to a molding polyline display along all of its edges in 3D views. If you wish, you can suppress the display of moldings on the Selected Edge by clicking the **Remove Molding from Selected Edge**  edit button or checking **No Molding on Selected Edge** in the molding polyline’s specification dialog. See [Selected Edge on page 212](#).

Suppressed moldings can be restored to the selected edge by clicking the **Add Molding to Selected Edge**  edit button or by unchecking **No Molding on Selected Edge**.

These edit buttons are also available for a selected Gutter, Ridge Cap, or Shadow Board polyline and for Custom Countertops. They are not, however, available for Rope Moldings. See [Roof Returns and Other Details on page 844](#), [Countertops on page 627](#), and [Rope Lights on page 669](#).

---

## Editing Molding Polylines

Molding polylines can be edited much the way CAD polylines are. See [Editing Open Polyline-Based Objects on page 224](#) and [Editing Closed Polyline-Based Objects on page 228](#).

Note: 3D Molding Polyline edges that slope rather than having a single height are best edited in a camera or elevation view. See [3D Views on page 1079](#).



Molding lines and polylines also can be edited in their specification dialogs. See [Molding Polyline Specification Dialog on page 938](#) and [3D Molding Polyline Specification Dialog on page 939](#).

## DELETING MOLDING POLYLINES

Molding polylines can be deleted like other objects using the **Delete**  edit button or the Delete key on your keyboard.

Molding Polyline are also deleted when the Delete Objects dialog is used to delete CAD objects. See [Deleting Objects on page 284](#).

---

## Molding Polyline Specification Dialog

To open the Molding Polyline Specification dialog, select a molding polyline or group of molding polylines and click the **Open Object** edit button.

The Molding Polyline Specification dialog has the following panels:

### GENERAL PANEL

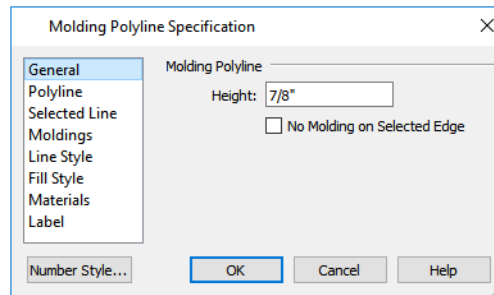

- Specify the Molding Polyline's **Height**, relative to 0.
- Check **No Molding on Selected Edge** to create blank section in the molding polyline along the selected line segment.

### POLYLINE PANEL

The POLYLINE panel states the **Length** of an open molding polyline, and the **Perimeter** and **Area** of a closed molding polyline. See [Polyline Panel on page 317](#).

### SELECTED LINE/ARC PANEL

The SELECTED LINE panel is available when the selected segment of the molding polyline is a line, as opposed to an arc. For more information, see [Line Style Panel on page 305](#).

The SELECTED ARC panel is available when the selected segment of the molding polyline is an arc, as opposed to a line. See [Arc Panel on page 312](#).

See, too, [Selected Edge on page 212](#) and [Change Line/Arc on page 256](#).

### MOLDINGS PANEL

The MOLDINGS panel can be found in dialogs throughout the program. See [Moldings // Profiles / Rails / Panels on page 927](#).

One setting on this panel is unique to the Molding Polyline and 3D Molding Polyline Specification dialogs:

- Check **Inside** to extrude the molding profile on the inside of closed polyline or right side of an open polyline.

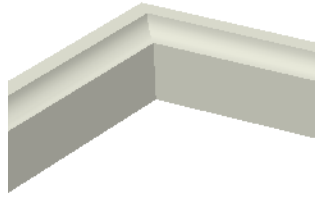

- When unchecked, the molding profile extrudes on the outside or left side of the polyline.

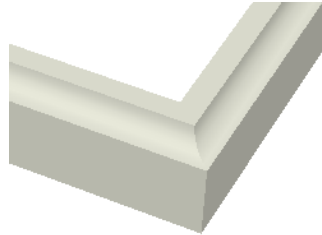

### LINE STYLE PANEL

The LINE STYLE panel can be found in dialogs throughout the program. For information about the settings on this panel, see [Line Style Panel on page 305](#).

### FILL STYLE PANEL

The settings on the FILL STYLE panel affect the appearance of the selected Molding Polyline in plan view. For more information, see [Fill Style Panel and Dialogs on page 193](#).

### MATERIALS PANEL

The MATERIALS panel can be found in dialogs throughout the program. For information about the settings on this panel, see [Materials Panel on page 1055](#).

### LABEL PANEL

Molding Polyline labels display when the “Polylines 3D, Labels” layer is turned on and use the Text Style assigned to that layer. See [Text Styles on page 538](#).

For more information about the settings on this panel, see [Label Panel on page 700](#).

### COMPONENTS PANEL

The information on the COMPONENTS panel can be used in the materials list. For more information, see [Components Panel on page 1330](#).

---

## 3D Molding Polyline Specification Dialog



Select a 3D molding polyline and click the **Open Object** edit button to open the 3D Molding Polyline Specification dialog.

The 3D Molding Polyline Specification dialog has the following panels:

## GENERAL PANEL

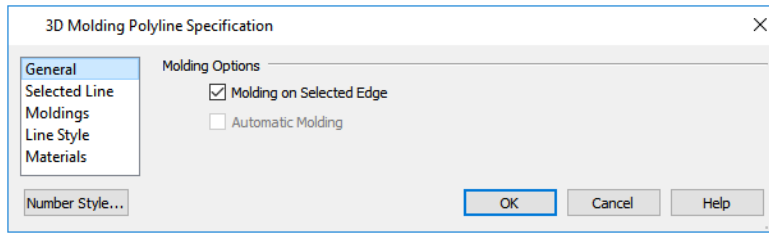

- Uncheck **Molding on Selected Edge** to turn off the display of the specified molding on the selected edge of the polyline. See [Selecting Objects on page 210](#).
- If the selected object is an automatically generated ridge cap, frieze molding, or shadow boards polyline, this check box's label will reflect the object type. See [Roof Returns and Other Details on page 844](#).

An **Automatically Generated** check box will be present if a ridge cap, frieze molding, or shadow boards polyline is selected. This check box is for reference only and cannot be edited. See [Roof Returns and Other Details on page 844](#).

- When this box is checked, the selected roof trim is updated whenever you rebuild the roof.
- If the selected object is edited, this box will become permanently unchecked. To restore the automatic updating behavior, the frieze, shadow boards, or ridge caps must be deleted and regenerated.

## SELECTED LINE PANEL

The **SELECTED LINE** panel is available when the selected edge of the 3D Molding Polyline is a line as opposed to an arc. Most of the settings here are the same as those on the **LINE** panel of the Line Specification dialog. See [Line Panel on page 304](#).

The **Length/Angle** settings in the 3D Molding Polyline Specification dialog are unique to this dialog.

Length/Angle	
Length:	24"
Angle In XY Plane:	0.0°
Angle From XY Plane:	90.0°

- **Length** specifies the 3D length of the selected edge of the 3D Molding Polyline.
- **Angle in XY Plane** specifies the counter-clockwise angle that the selected edge makes with the positive X axis when viewed from above, as in plan view.
- **Angle from XY Plane** specifies the angle that the selected edge makes with the horizontal XY plane when viewed from the side, as in a cross section/elevation view. A positive value means that the line slopes up; a negative value means that it slopes down.

## SELECTED ARC PANEL

The **SELECTED ARC** panel is available when the selected segment of the 3D molding polyline is an arc as opposed to a line.

Other specification dialogs have a **SELECTED ARC** panel; however, most of the settings work differently for 3D Molding Polyline than they do for other objects in the program.

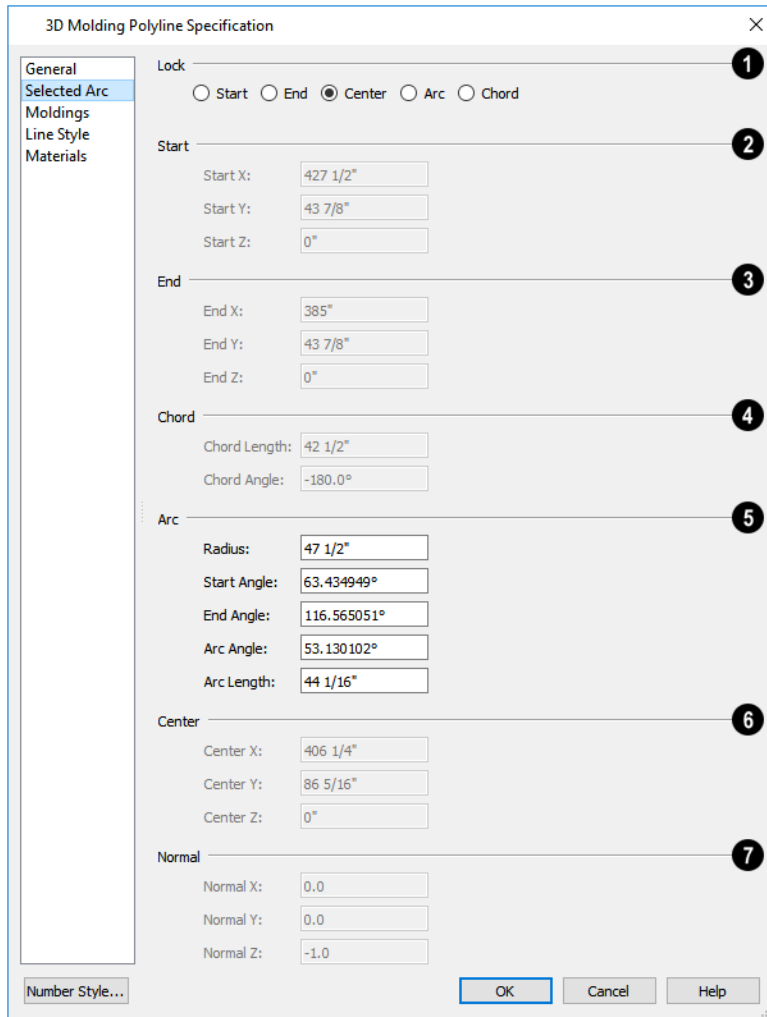

### 1 Lock

The **Lock** options specify how changing one value affects other values.

- Select **Start** to keep the start and center of the arc fixed and move the end.
- Select **End** to keep the end and center of the arc fixed and move the start.
- Select **Center** to keep the center of the arc fixed and move the start or end.
- Select **Arc** to keep the arc geometry fixed and translate the arc.
- Select **Chord** to keep the start and end fixed and change the radius.

### 2 Start

Specify the coordinates of the selected arc's **Start** point. Only available when **Lock End** or **Lock Arc** is selected.

### 3 End

Specify the coordinates of the selected arc's **End** point. Only available when either **Lock Start** or **Lock Arc** is selected.

### 4 Chord

Specify the length and angle of the selected arc's **Chord**. Only available when **Lock Start** or **Lock End** is selected.

- Specify the **Chord Length**, which is the 3D distance between arc start and end.
- Specify the **Chord Angle**: the angle created by the chord and the positive X axis.

### 5 Arc

The **Arc** options specify radius, angle and length values of the selected arc:

- **Radius** - The distance from the arc to the arc center.
- **Start Angle** - The angle created by a line from the arc center to the start and the positive X axis.
- **End Angle** - The angle that a line from the center to the end
- **Arc Angle** - The angle created by a line from the arc center to the start and a line from the center to the end.
- **Arc Length** - The length of the arc.

### 6 Center

Specify the coordinates of the selected arc's **Center** point. Only available when **Lock Arc** is selected.

### 7 Normal

The items under the **Normal** heading state the coordinates of the normal of the plane that the arc exists in. The normal is a vector that is parallel to that plane and is expressed as a line between two points: (0,0) and the point defined in the dialog.

- The arc direction in plan view is counter clockwise if the normal has a positive value on the z axis (0,1) and clockwise if the value on the z axis is negative (0,-1).

## MOLDINGS PANEL

The **MOLDINGS** panel can be found in the specification dialogs for a variety of different objects in the program. See [Moldings // Profiles / Rails / Panels on page 927](#).

One setting on this panel is unique to the Molding Polyline and 3D Molding Polyline Specification dialogs:

- Check **Inside** to extrude the profile on the inside or right side of the polyline.

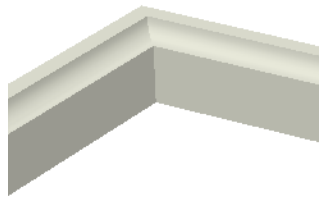

- When unchecked, the profile extrudes on the outside or left side of the polyline.

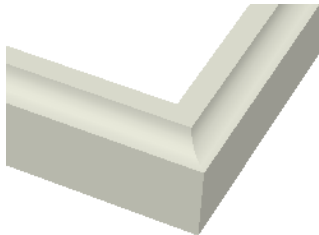

## LINE STYLE PANEL

The LINE STYLE panel can be found in dialogs throughout the program. See [Line Style Panel on page 305](#).

If an automatic frieze or shadow board polyline is edited, it will no longer be considered Automatic and the **Default Layer** check box on this panel will be unchecked.

## MATERIALS PANEL

The MATERIALS panel is found in dialogs throughout the program. See [Materials Panel on page 1055](#).

## COMPONENTS PANEL

The information on the COMPONENTS panel can be used in the materials list. For more information, see [Components Panel on page 1330](#).

---

# Frieze Moldings

Frieze moldings, also known as frieze boards, are mounted below the eaves of roof planes and can be generated automatically using the Build Roof dialog.

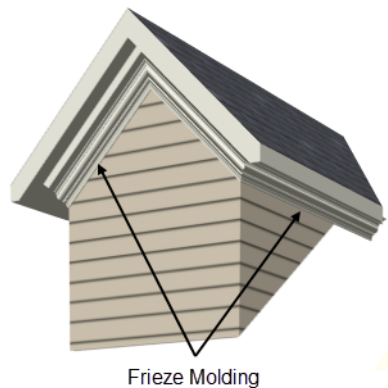

## CREATING FRIEZE MOLDINGS

To create automatic frieze moldings, specify a molding profile on the FRIEZE panel of the Build Roof dialog and then build the roof. See [Frieze Molding on page 847](#).

## DISPLAYING FRIEZE MOLDINGS

By default, frieze molding displays in 3D views but not in plan view and its default layer, “Roofs, Trim”, is locked. See [Layer Display Options Dialog on page 179](#).

## SELECTING FRIEZE MOLDINGS

To select a frieze molding, its layer must first be unlocked and turned on. See [Locking Layers on page 178](#). In floor plan or a cross section/elevation view, click on a frieze molding. If the wall behind it is selected, click the **Select Next Object**  edit button or press the Tab key until the frieze molding is selected. When the frieze molding is selected, the Status Bar says “3D Molding Polyline.” See [The Status Bar on page 24](#).

## **EDITING FRIEZE MOLDINGS**

Like other 3D Molding Polylines, frieze molding can be edited much the way CAD polylines are in floor plan and cross section/elevation views. See *Editing Molding Polylines on page 937*.

Frieze molding can also be edited in the 3D Molding Polyline Specification dialog. See *3D Molding Polyline Specification Dialog on page 939*.

If you edit a frieze molding, it is no longer considered an Automatic frieze and will not be deleted and replaced when the roof is rebuilt. Once **Automatic** is unchecked, it cannot be checked again. To restore the automatic updating behavior of frieze molding, it must be regenerated.



# The Library

## Chapter 27

Chief Architect Premier’s library offers thousands of symbols, materials, and images that can enhance any plan.

New library catalogs and enhancements are made available by Chief Architect Software on a continuing basis and are available for download for the current program version.

You can also customize items from the library or import new items from outside the program and then save them in the library for future use.

The Library Browser shares its window with the Project Browser, which is discussed separately. See *Project Browser on page 58*.

### TOPICS

<b>The Library Browser</b> .....	<b>946</b>
<b>Searching and Filtering the Library</b> .....	<b>953</b>
<b>Find in Library</b> .....	<b>960</b>
<b>Library Content</b> .....	<b>961</b>
<b>Downloading Library Content</b> .....	<b>963</b>
<b>Importing Library Catalogs</b> .....	<b>964</b>
<b>Adding Library Content</b> .....	<b>965</b>
<b>Organizing the Library</b> .....	<b>967</b>
<b>Editing Library Objects</b> .....	<b>970</b>
<b>Exporting Library Catalogs</b> .....	<b>972</b>
<b>Placing Library Objects</b> .....	<b>972</b>
<b>Select Library Object Dialog</b> .....	<b>974</b>
<b>Place Library Object Button</b> .....	<b>975</b>
<b>Replace From Library</b> .....	<b>976</b>

---

## The Library Browser



The Chief Architect Library Browser side window allows you to manage the contents of the library as well as add library content to your drawings.

### ***To open or close the Library Browser:***

- Select **View > Library Browser**.
- Click the **Library Browser**  button.
- Press **Ctrl + L** on your keyboard.

When **Double-Click Closes Browser** is checked in the Preferences dialog, you can also close the Library Browser by double-clicking on an item in the Filter Results. Doing this will also close any other side windows that the Library Browser is docked with. See [Library Browser Panel on page 100](#).

By default, the Library Browser is docked to the right side of the program window, but it can be undocked or docked to another side if you wish. See [Side Windows on page 17](#).

The Library Browser has six panels:



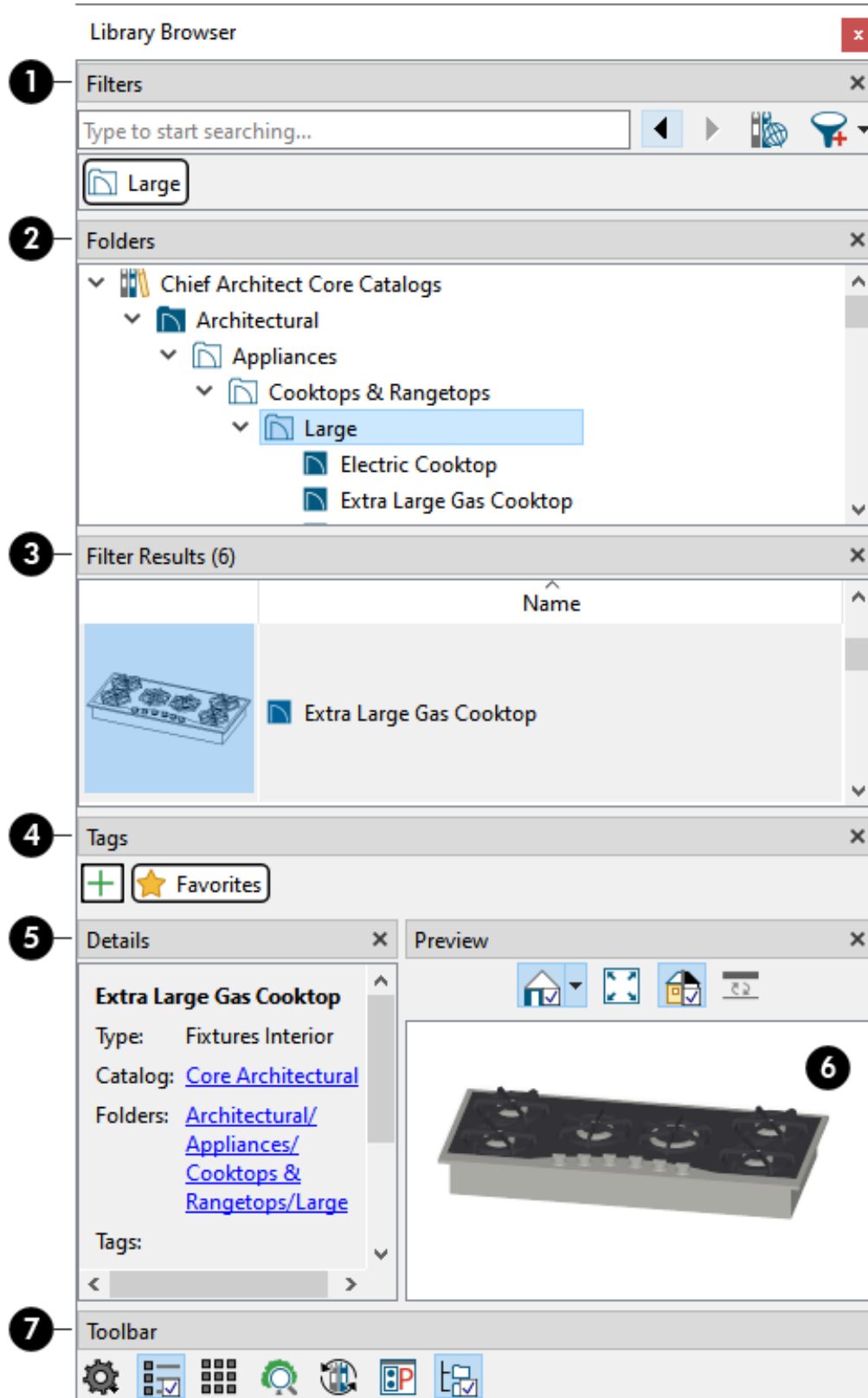

- Filters and search options
- Folders tree list
- Filter Results
- Details
- Preview



### 1 Filters

Search or filter the library to find the content you need. Filter Results are reported below. See *Searching and Filtering the*

*Library on page 953.*

- Type in the text field. A drop-down list of search results will appear below the field that updates as you type.
- Click on a line item to use that item as a search parameter.
- You can also type and press the Enter key to use your text as a search parameter.
- Click the **Advanced Search**  button to refine the current search parameters as well as create custom filters. See *Advanced Search Dialog on page 956.*
- When **Include Web Results**  is toggled on, content that is available for download will be included in the Filter Results. Turn this option off to only include content already present in the library in the Filter Results.
- All currently active search parameters are listed immediately below, each in a rectangle border.
- You can also add search parameters to the current filter by selecting Folders and/or Tags.
- Click on an item here to stop using it.
- Click the **Go Back in History**  and **Go Forward in History**  buttons to cycle between filters that have been active during the current program session.
- The tree list in the Folders panel is filtered to only show content that matches your search criteria, and the Filter Results panel below is populated with all items that match the active search parameters.
- Click the arrow to the right of the Advanced Search button to select a filter from the drop-down list. “Not Filtered” will be the only available option until you either specify a search parameter, select a folder in the Folders panel, or create a custom filter.

## 2 Folders

The contents of the Library are listed in a directory tree and can be browsed here. When you select a folder, it will be listed as a search parameter under Filters, above, and its contents will be listed under Filter Results, below.

- The Folders tree list has five categories: Chief Architect Core Catalogs, Chief Architect Bonus Catalogs, Manufacturer Catalogs, User Catalog and Trash. See *Library Content on page 961* and *Deleting Library Items on page 970.*



If the Chief Architect Core Catalogs, Bonus Catalogs, or Manufacturer Catalogs are empty, they will not be listed in the Folders tree list. See *Downloading Library Content on page 963.*

- The basic structure of the directory tree is:



- Library items are always placed in alphabetical order within their hierarchy.

- Navigate the Folders panel tree list using the mouse and/or keyboard:
- Click the gray Expand arrow pointing to a catalog or folder to display its contents. Once expanded, you can click the black Collapse arrow pointing downward to close it again. Scroll through the list using either the scroll bar on the right or the mouse scroll wheel.
- You can also browse the list using the arrow keys on your keyboard. The up and down arrow keys navigate up and down in the list, while the left and right arrow keys expand and contract a selected catalog or folder.
- Click on an item to select it. When you select an individual item, information about it will be shown in the Details and Preview panels below and you can place or apply it in your drawing.

### 3 Filter Results

All library items that match the currently active search parameters listed in the Filters panel are listed here. Their total number is reported in parentheses.

- Like the Folders list, the Filter Results can be navigated using the mouse and/or keyboard.
- Click on an item to select it: information about it will be shown in the Details and Preview panels below, and you can place or apply it in your drawing. Basic information about it also displays in the program's Status Bar. See *The Status Bar on page 24*.
- Multiple items can be selected for organization and limited editing purposes but cannot be placed in a drawing.



### 4 Tags

Tags allow you to create custom categories which you can then assign library items to. Tags can be used as filters themselves, or as search attributes in more complex filters. The Tags panel does not display by default: click the Settings button in the Toolbar panel below to control which panels display.

- All available Tags are listed in this panel. Click on one to use it as a search parameter listed in the Filters panel, above. The currently selected Tag has a dashed outline.
- Favorites is the installed system Tag.
- Click the **Create New**  button to open the New Library Tag dialog and type a short, descriptive name for a new Tag.
- Right-click on a custom Tag to select **Rename**, **Change Color**, or **Delete** from the contextual menu.

### 5 Details

Information about the selected library item is reported here, including:

- **Type** - See *Symbol Categories on page 1003*.
- **Catalog** - See *Library Content on page 961*.
- **Folders** - See *Organizing the Library on page 967*.
- **Tags** - See *Creating and Using Tags on page 955*.
- **Notes** - You can add a Note to any unlocked library item by clicking the **Edit Notes**  button in this panel. A text field becomes available and you can choose to **Save Notes**  as well as **Insert Hyperlink** .

### 6 Preview

When an item is selected either the Folders or Filter Results panel, a representation of the item displays in the Preview

panel. If the selected object is a 3D symbol, you can rotate and zoom in or out on the Preview using the mouse. Two-dimensional objects, such as CAD Blocks or Line Styles cannot be adjusted in this manner in the Preview panel.

Options above the preview pane vary depending on the type of object selected:

 The Standard, Vector View, and Glass House Rendering Techniques can be applied to the preview for architectural objects, as can Plan View. See [Rendering Techniques on page 1150](#). You can specify whether Standard or Vector View is used by default in the Preferences dialog. See [Appearance Panel on page 95](#).

 The Physically Based, Standard, and Vector View Rendering Techniques can be applied to the preview for materials.

 **Fill Window** sizes and positions the selected object so that it fills the preview pane as much as possible.

 The display of **Color** can be toggled on and off in the preview for all item types except CAD Details and Line Styles.

 The display of **Line Weights** can be toggled on and off for Fill Patterns.

 A selected material will display on a shape in the Preview panel. The initial shape is a Teapot, but you can select a Cube, Sphere, or 2D Plane instead if you prefer. The object shape selection is also shared with the Define Material dialog. See [Define Material Dialog on page 1066](#).

## 7 Toolbar

The toolbar at the bottom of the browser aids in searching, displaying panels, and managing library content. The settings here are saved between program sessions.

 The **Settings** menu lets you select which Library Browser panes are presented and which are hidden.

 **List Mode** displays items in the Filter Results pane in a scrollable horizontal list with item name and preview thumbnail.

 **Grid Mode** displays items in the Filter Results pane as a grid of thumbnail images.

 Open the Plant Chooser dialog. See [Plant Chooser Dialog on page 1295](#).

 **Update Library Catalogs** downloads and installs updates to your installed catalogs to include the latest content. See [Updating Library Catalogs on page 962](#).





 Open the Preferences dialog, where display properties for the Library Browser can be controlled. See [Library Browser Panel on page 100](#).

 **Search Subfolders** includes the contents of subfolders when a folder is an active search parameter. Turn this off to only include items saved in the folder itself, at the folder level: not in subfolders.

## CUSTOMIZING THE BROWSER

The Library Browser can be resized, moved, as well as docked with other Side Windows in the configuration of your choice. To return the Library Browser to its original position and size, click the **Reset Side Windows** button in the Preferences dialog. See [Side Windows on page 17](#).

The panels in the Library Browser are customizable:

- You can control which Library Browser panels display by clicking the **Settings**  button.
- To adjust the height or width of a panel, place the pointer over the split bar you want to move. When the splitter cursor  displays, click and drag. See *Dialog Panel Splitters on page 22*.
- Panels can be rearranged within the Library Browser side window. Click and drag a panel's title bar: When a highlighted space is created at the location you want, release the mouse button.
- When your panel arrangement meets your needs, you can lock it: click the **Settings**  button, then select **Lock Panels** .
- To return the Library Browser's panels to their original configuration, click the **Reset Panel Layout** button in the Preferences dialog. See *Library Browser Panel on page 100*.

## USING THE CONTEXTUAL MENU

A number of important library functions can be accessed using the contextual menu. Right-click on an item in the Folders or Filter Results panel to open a contextual menu displaying options related to that item. See *Contextual Menus on page 19*.

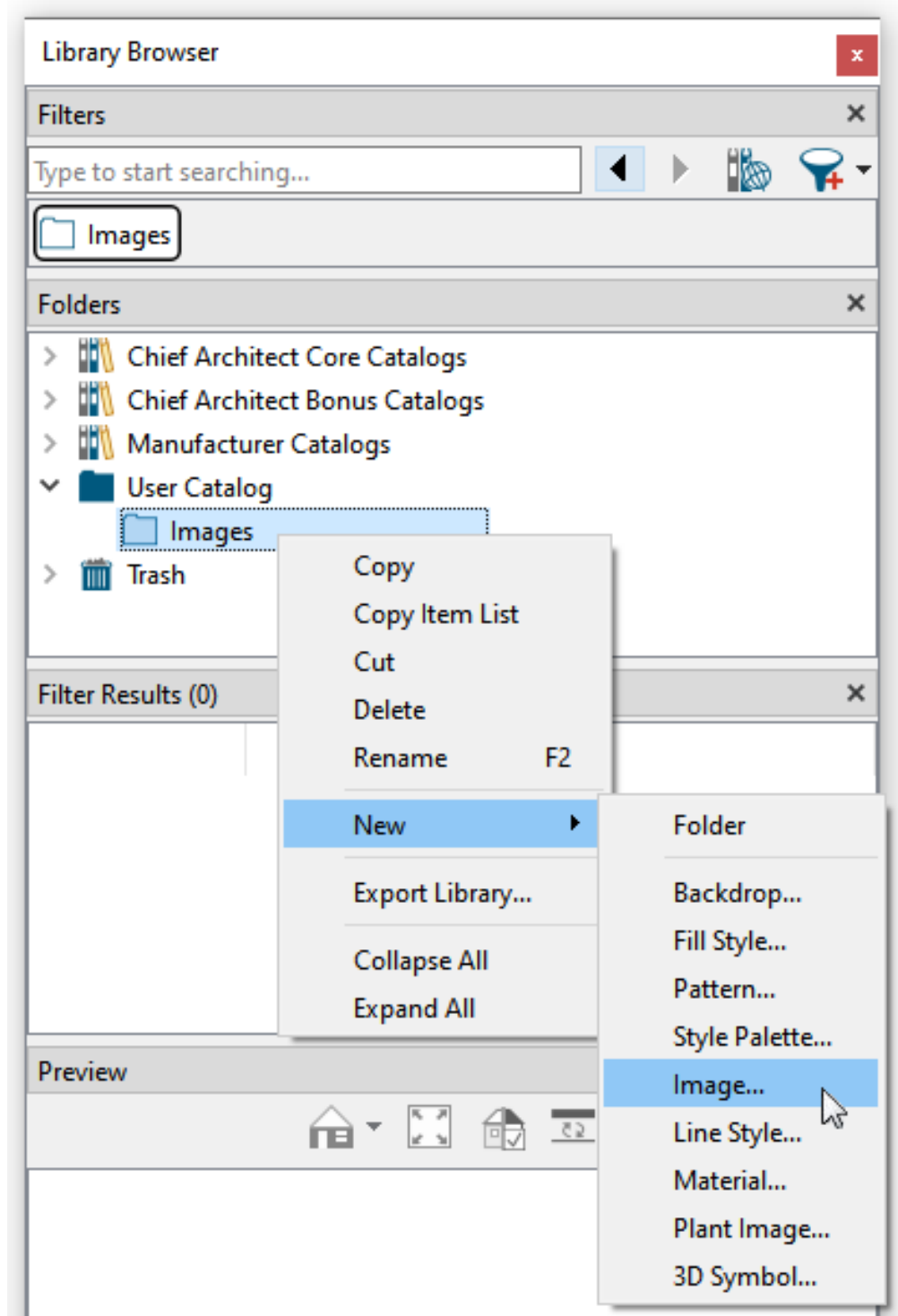

The options in the contextual menu vary depending on the item selected, but may include:

- Update
- Cut/Copy/Paste
- Copy to User Catalog
- Copy Item List



- Search in Folder(s)
- New
- Rename
- Delete
- Move to Folder(s)
- Tags
- Export Library
- Open Object/Open Symbol
- Edit CAD Block
- Manage Folders
- Search Attributes
- Text Macro Management
- Place Molding Profile
- Expand All/Collapse All
- Show in Folder
- Vacuum
- Restore from Trash

## KEYBOARD COMMANDS

The Library Browser can be navigated using the arrow keys on your keyboard.

- The right and left arrow keys expand and collapse folders.
- The up and down keys change which library object is currently selected.
- Select an item and press F2 to rename it.
- Select an item and press the Delete key to delete it.

## EXPAND/COLLAPSE ALL

When a library category or folder is selected in the Folders pane, **Expand All** and **Collapse All** are available in the contextual menu, allowing you to expand or contract its contents in the tree list. All folders located within the selected folder are expanded or contracted, as well.

---

# Searching and Filtering the Library

Depending on how much library content you have imported or customized, the tree list in the Folders panel can be extensive. The Library Browser filtering options let you focus your searches using parameters that you define. There are several approaches to finding content.

## SEARCHING THE LIBRARY

The most straight-forward way to find content in the Library Browser is to search for it. You can search for item names, folder names, object types, tags, and other search attributes.

When Include Web Results is enabled, content available for download from the Chief Architect 3D Library is also included in the Search results. Be sure to scroll down the Search drop-down list as well as the Filter Results.

### To search the Library Browser

1. Click in the Search text field at the top of the Filters panel and begin typing a keyword to search for.
2. As you type, a list will drop down below the text field, showing search results that update as you type.

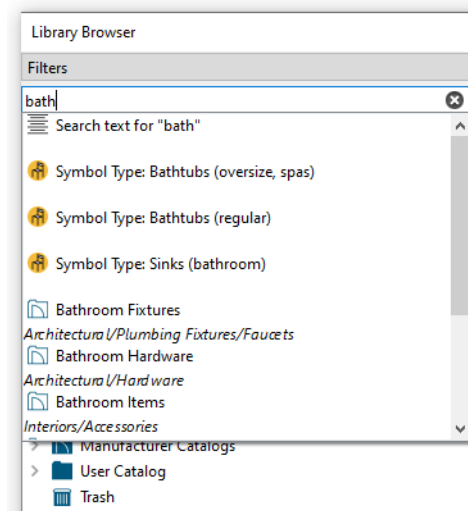



The Library Filter drop-down list with search results.

- Use the keyboard Arrow keys or scroll bar to scroll through the drop-down list.
- Click on a line item to use that item as a search parameter that influences how the Folders and Filter Results panels are populated, below.



 When Include Web Results is enabled, the search results include downloadable content available in the Chief Architect 3D Library. See [Library Content on page 961](#).

3. You can use Boolean keywords and quotation marks to refine your search:
  - Boolean keywords (NOT, AND, OR), capitalized and with spaces, can be used. Shortcuts (!, +, |) can be used, as well.
  - Boolean keywords' are prioritized from highest to lowest in this order: not, and, or. Parentheses can also be used.
  - Use quotation marks "" to search for an exact word or phrase. Quotation marks around a Boolean keyword will treat the keyword as a normal search term.
  - Press the Enter key on the keyboard to populate the Filter Results panel with items that match your search text.
4. You can also search for Object Attributes, which are listed in the Advanced Search dialog:
  - Type
  - Style
  - Manufacturer
  - Symbol Type
  - Symbol Options

- Symbol Placement
  - Hardware Options
  - Has (Material Maps)
  - Plant is 3D
5. To combine an attribute with a keyword, use this format: Attribute: keyword.
  6. To restrict your search to one or more folders, select them in the Folders panel, then right-click on the selection and select Search in Folder(s). The selected folder(s) will act as filters until they are actively removed or another filter is selected.
  7. Repeat steps 2 - 5 to add additional parameters to the current filter if you wish.
  8. Click the **Advanced Search**  button to further refine your search as well as create a Custom Filter. See below.
  9. You can click the **Clear**  button on the right side of the Search text field to remove anything typed in this field.
  10. Right-click on an item in the Search Results list and select **Show in Folder** to view the item's location in the Folders list.

 You can use the Go Back and Go Forward in History buttons in the Filter panel of the Library Browser to cycle between filters that have been active during the current program session.

## CREATING AND USING TAGS

Tags let you group library items into categories that make library filtering more efficient for you. There are numerous uses for Tags, for example: to group items that you use often by drawing task, design style, or a particular project. Chief Architect has a single system tag, **Favorites** , but you can create your own by clicking the **Create New**  button in the Tags panel of the Library Browser. See *The Library Browser on page 946*.

To add a tag to an item, right-click on it and select **Tags>** from the contextual menu. In the submenu, check the box beside each Tag that you would like to add to the selected item and then select **Apply**. See *Using the Contextual Menu on page 951*.

You can also select **Tags> Manage Tags** from the contextual menu for one or more selected objects to open the Manage Library Tags dialog.

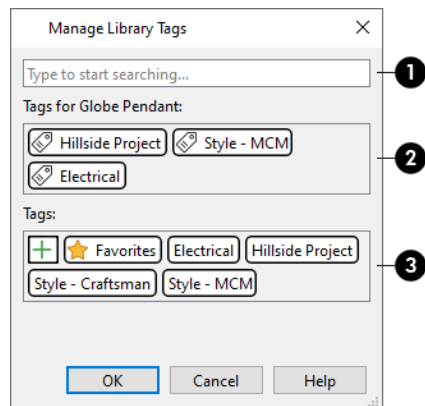

## 1 Search

If you have created a large number of Tags, you can type in this field to search for a particular Tag name.

- A drop-down list of search results will appear below the field that updates as you type: click on an item in that list to select and apply it to the selected objects.
- You can also create a new Tag using what you have typed as its name.

## 2 Tags for Item/Common Tags for Items

The names of Tags assigned to the selected object(s) are reported here.

- When multiple objects are selected, only the Tags assigned to all objects will be named here.
- Click on a name to remove that Tag from the selected object(s).

## 3 Tags

The names of all available Tags are listed here.

- Click on the name of a Tag to assign it to the selected object(s).
- As in the Tags panel of the Library Browser, you can **Create New**  Tags as well as right-click on a Tag's name here and **Rename, Change Color, or Delete**.

To use a tag to find items in the Library Browser, simply click on its name in the Tags panel. All library items that have been assigned that tag will be listed in the Filter Results, where you can select them for use in your drawing. You can also include Tags in custom saved Filters.

## FILTERING THE LIBRARY

A Library Filter is a set of one or more search parameters that allows you to search for specific content by restricting what is listed in the Folders and Filter Results panels. Library Filters can include plain text, a Symbol Type, an object Type, a Folder, and/or one or more Tags. You can add items to a filter by typing in the Search field, selecting a folder in the Folders panel, or selecting a Tag. Depending on which parameters are already in use, it is possible that a parameter may be removed when a new one is added.

To fine-tune a set of search parameters, or to save a set of parameters for future use, click the **Advanced Search**  button.

Any filters that you create will be in the **Active Filter** drop-down list at the top of the Library Browser. Select a filter from the list to display content in the library tree list according to its settings. See *The Library Browser on page 946*.

## ADVANCED SEARCH DIALOG

 Click the **Advanced Search** button in the Library Browser to refine your search results. You can also create custom filters in this dialog.

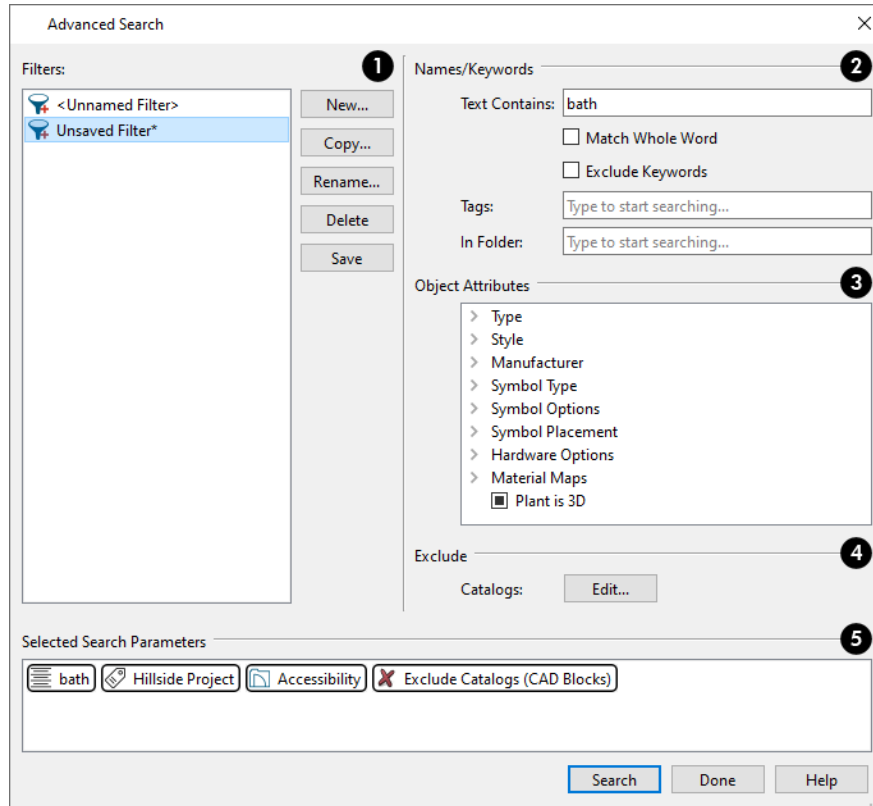

## 1 Saved Filters

A list of all saved filters is found here. See [Creating Custom Filters](#), below.

- Click on a saved filter to select it and edit its search parameters using the options on the right.
- Click the **New** button to create a new filter using the currently selected parameters. In the New Library Filter dialog, type a short, descriptive, unique name for the new filter.
- Click the **Copy** button to create a new filter with search parameters that are identical to the selected filter.
- Click the **Rename** button to rename the currently selected saved filter.
- Click the **Delete** button to delete the currently selected saved filter.
- Click the **Save** button to save any changes made to the selected filter. Filters with unsaved changes are can be identified by an asterisk after their names.

## 2 Names/Keywords

- **Text Contains** - Type the text you would like to use as a search parameter. When you press the Enter key, it will be added to the Selected Parameters list.
- Check **Match Whole Word** to match the entire keyword or words with the complete name of an item.
- Check **Exclude Keywords** to ignore search attribute keywords when searching. See [Search Attributes](#), below.
- **Tags** - When you begin typing in the text field, a drop-down list of available Tags will appear below the field and will update as you type. Click on a line item to add it to the Selected Parameters list.

- **In Folder** - When you begin typing in the text field, a drop-down list of folder names that match what you typed will appear below the field and will update as you type. Click on a line item to add to the Selected Parameters list.

### 3 Exclude Catalogs

Click this button to open the Exclude Catalogs dialog, where you can select catalog-level library items to exclude from your search.

### 4 Attribute Parameters

Select various object attributes to include in your search.

- Check the box beside an option to use it as a search parameter. For Material Maps and Plants, a "no change" state allows you to include items in your search regardless of whether they have a particular attribute.
- Click the arrow beside an attribute category to expand it:
  - **Type** - A variety of library item types is listed here.
  - **Style** - A selection of architectural and design styles is listed here. See [Search Attributes](#), below.
  - **Manufacturer** - A list of brands with Chief Architect Manufacturer Catalogs is listed here. If **Include Web Results**  is toggled on, all available manufacturers are listed; if not, only those actually installed in the Library Browser are listed. See [Manufacturer Catalogs on page 961](#).
  - **Symbol Type** - The different types of symbol objects are listed here. See [Symbol Categories on page 1003](#).
  - **Symbol Options** and **Symbol Placement** - These options correspond to settings in the Symbol Object Specification dialogs. See [Options Panel on page 994](#).
  - **Hardware Options** - Options specific to hardware symbols are listed here. See [Door Hardware on page 553](#) and [Cabinet Hardware on page 638](#).
  - **Material Maps** - These options let you search for materials based on the types of material maps they have. A "no change" state searches for materials regardless of whether it has a particular map file. See [Material Maps on page 1050](#).
- **Plant is 3D** - This option lets you search for either 3D plant symbols or 2D plant images. A "no change" state searches for both. See [Plant Tools on page 1294](#).

### 5 Selected Search Parameters

The currently selected parameters are listed here.

- Parameters have icons that indicate which type of data they restrict.
- Click on a parameter from the list.

## EXCLUDE CATALOGS DIALOG

Click the **Edit** button beside **Exclude Catalogs** in the Advanced Search dialog to open this dialog and select library catalogs to exclude from the current Filter, regardless of the active search parameters.

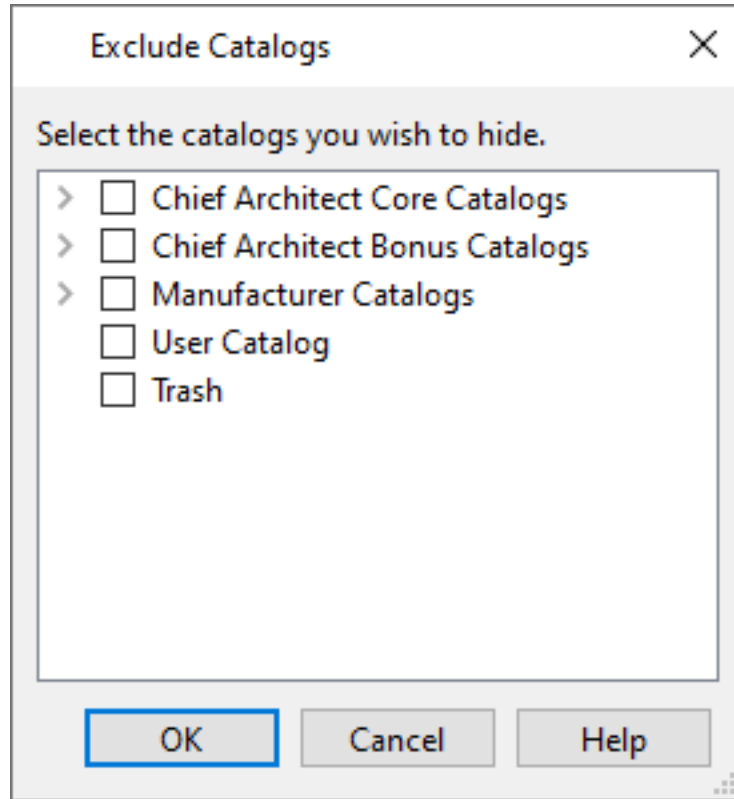

The contents of the tree list in the Folders panel of the Library Browser are listed here. Check the box beside any catalog's name to exclude it from the currently active filter.

## SEARCH ATTRIBUTES

The Search Attributes dialog lists the keywords and styles associated with a selected library object. Keywords and styles can be used to locate the object when performing a library search. See *The Library Browser on page 946*.

To open the Search Attributes dialog, right-click on an individual item and select **Search Attributes** from the contextual menu. See *Using the Contextual Menu on page 951*.

While the Search Attributes for items in the User Catalog can be edited, those belonging to items in the Core, Bonus, or Manufacturer Catalogs can only be viewed.

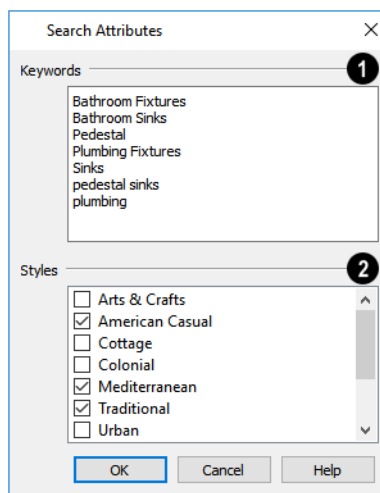

## 1 Keywords

Any searchable keywords associated with the object display in the list. Click in the list box and type in any additional keywords that you would like to use. Each keyword should be on its own line in the list.

## 2 Styles

Check the box beside any architectural or design styles that you want to associate with the object.

---

# Find in Library



You can find out whether a selected object is saved in the library and if so, where, using the **Find Original in Library** edit tool.

The **Find Original in Library** edit tool also allows you to locate any objects inserted into the selected object as well as any materials or moldings assigned to it. See *Inserted Objects on page 973*.

In addition, this tool provides a means of adding your choice of the object and/or any inserted and assigned objects to the library. See *Add to Library As on page 966*.

## FIND IN LIBRARY DIALOG

The Find in Library dialog opens when you select one or more objects and click the **Find Original in Library**  edit button. This dialog lists all of the selected objects as well as all objects assigned to and inserted into them.

Highlighted line items are categories that may have multiple components beneath them.

- Check the box beside a line item to find that object in the library.
- Check the box beside a category heading to select all items in that category.

When you click OK, the dialog will close and one of three things will happen:

- If a single line item was selected in the Find in Library dialog was clicked, that item will be selected in the tree list of the Library Browser.
- If the single line item is not found in the library, a message box will inform you of this and give you the option of adding it to the library.
- If multiple line items were selected, the Show in Library Results dialog will open, summarizing the status of each.

## SHOW IN LIBRARY RESULTS

If multiple line items are selected in the Find in Library dialog, the Show in Library Results dialog will report where, or if, they are found in the library.

Each line item selected in the Find in Library dialog is listed here.

- Click on a line item to select it. Multiple lines can also be selected. See *Shift and Ctrl Select on page 214*.
- Click the **Show in Library** button to locate and select the selected line item in the tree list of the Library Browser. Not available if the selected item is “Not Found in Library Browser”, or if multiple line items are selected.
- Click the **Add to Library** button to add the selected line item(s) to the User Catalog in the library. See *Add to Library As on page 966*.
- Click the **Done** button to close the dialog.



---

## Library Content

The Chief Architect Premier library has five categories: Chief Architect Core Catalogs, Chief Architect Bonus Catalogs, Manufacturer Catalogs, User Catalog and Trash.

### CHIEF ARCHITECT CORE CATALOGS

The Chief Architect Core Catalogs category contains a wide selection of 3D symbols, images, CAD objects, and materials. If you install the program from USB drive, this library content will also be installed; if you download the software, you will be able to download the Core Catalogs separately, after the program is installed.

When you launch the program for the first time, it will ask if you want to download the Core Catalogs. Click Yes to begin the download. If you click No, you can download at any time by selecting **Library> Install Core Content** from the menu.

### CHIEF ARCHITECT BONUS CATALOGS

Chief Architect regularly posts new library catalogs available for download. Select **Library> Get Additional Content Online**  from the menu to access the bonus catalogs and content.

Most Bonus Catalogs can be purchased for a nominal fee, while others are available free of charge. In addition, some Bonus Catalogs are only available to Chief Architect Support and Software Assurance program members. For more information, visit [chiefarchitect.com](http://chiefarchitect.com).

### MANUFACTURER CATALOGS

A variety of name brand library catalogs is available for download on the Chief Architect website with content ranging from materials to fixtures to CAD blocks.

Select **Library> Get Additional Content Online**  to access these Manufacturer Catalogs.

As with the Bonus Catalogs, some Manufacturer Catalogs are available free of charge while others can be purchased, and some are available for Support and Software Assurance members only.

### THE USER CATALOG



The User Catalog is the location for items that you add to the library either from a drawing or by importing. See [Adding Library Content on page 965](#).

You can create and organize custom library folders and imported items such as symbols, images, backdrops, CAD blocks, line styles, and materials. See [Organizing the Library on page 967](#).

### COPY ITEM LIST

**Copy Item List** is available in the contextual menu when a library category or folder is selected in the Library Browser Directory Pane. Select this option to copy a list of all objects in the selected library item to the system clipboard. You can then paste this list into a text application such as Notepad. See [To Copy, Cut and Paste text on page 515](#).

## UPDATING LIBRARY CATALOGS

The Chief Architect Core Catalogs, Bonus Catalogs, and Manufacturer Catalogs are updated periodically to include new and improved content. The program automatically checks for updates when it is launched and will indicate that updated content is available by displaying the **Update**  icon to the right of the Core, Bonus and/or Manufacturer Catalog categories. This icon is also stamped onto the folder for individual Bonus and Manufacturer catalogs with updated content available: .



To update the an individual catalog or all catalogs in a category, right-click on its name in the Folders list and select **Update** from the contextual menu. See [Using the Contextual Menu on page 951](#).



You can update all of your installed catalogs at once by selecting **Library> Update Library Catalogs** at any time. The program will gather information about the content in each of these three categories, and then download and replace any content that is not up-to-date.

As catalogs are updated, you may see a progress indicator at the bottom of the Library Browser. When the process is finished, the Catalog Update Summary dialog will report which catalogs were updated and the status of each update. See [Download Progress on page 963](#).

## LIBRARY CONTENT LOCATION

All library content aside from your User Catalog is stored in the **System Library Database Folder**. By default, this folder is created in the directory intended for shared application data in your operating system (C:\ProgramData in Windows; /Library/Application Support in macOS).

The Chief Architect User Catalog File, User\_Library.calib, is saved in the **User Library Folder**, which is located in the Chief Architect Premier X15 Data folder by default. See [Chief Architect Premier Data on page 37](#).

You can specify a different location for both if you wish in the Preferences dialog. If you choose a removable drive or network location, library slowness may result. See [Folders Panel on page 106](#).

If you choose to use a different location for your User Catalog, your existing User Library content as well as your Backdrops, Images, Patterns, and Textures folders will be moved there, as well. It is important that you specify a directory on a hard drive with sufficient space to hold these files.



Library catalogs are not designed to be shared between program titles or versions. Items designed for use in Chief Architect Premier X15 are not compatible with earlier program versions.

## BACKING UP CUSTOM CONTENT

The best way to back up your custom library content is to export the items in your User Catalog, as this will ensure that the textures used by custom materials or imported symbols are not lost. See [Backing Up Your Files on page 42](#).

Exported libraries use the **.calibz** file format: a zipped file type that can include textures and images along with other library data.

### *To back up your custom library content*

1. Launch Chief Architect and open a plan file.
2. If the Library Browser is not open, select **View> Library Browser**  from the menu.
3. Right-click on a folder or item in the User Catalog.

4. Select **Export Library** from the contextual menu.
5. The Export Library Data dialog is a typical Save dialog. See [Exporting Files on page 41](#).
  - Notice that the file type in the Save as type field is “Library File with Textures/Images (\*.calibz)”.

---

## Downloading Library Content

The Chief Architect Core Catalogs, Chief Architect Bonus Catalogs, Manufacturer Catalogs are all available for internet download.

### CORE CATALOGS



When you launch Chief Architect for the first time, you will be asked if you want to download the Core Catalogs. Click Yes to begin the download.

If you click No, you can download at any time by selecting **Library> Install Core Content** from the menu.

### BONUS AND MANUFACTURER CATALOGS



Bonus and Manufacturer Catalogs can be downloaded from our website, [www.chiefarchitect.com](http://www.chiefarchitect.com). Select **Library> Get Additional Content Online** to launch your default internet browser to our Content Resources page.

When **Include Web Results**  is toggled on, content that is available for download will be included in the Filter Results. Items in the Filter Results that are not downloaded will have the Available Online  watermark. Right-click on one these items and select **Download Catalog** from the contextual menu to download it. If you are not logged in to your online Chief Architect account, you will be prompted to do so. See [Chief Architect Account Login on page 1223](#).

### DOWNLOAD PROGRESS

When library content is downloading, a green progress bar will display at the bottom of the Library Browser. If you choose to download the Core Catalogs while the library is not open, the Browser will open so the progress indicator can display.

Click on the progress bar to display the name of the current file being downloaded, the total amount of data to be downloaded in KB, and the amount downloaded so far.

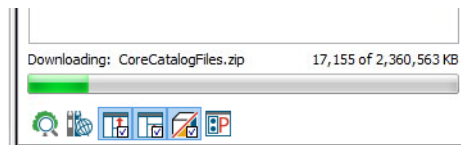

### PAUSING AND RESUMING

Library downloads can only take place while Chief Architect is running. If you close the program while a download is in progress, a dialog will confirm whether you wish to stop the download.

- Click **Stop Download and Close Program** to stop the download and close the program.
- Click **Cancel** to leave the program open and continue downloading.

Most catalogs are composed of a single file. If you stop the download midway, none of the downloaded data will be retained.

The Core Catalogs, on the other hand, contain a large volume of data saved in multiple files. If you close the program and stop the Core Catalogs download midway, only data associated with the file currently being downloaded will be lost. You can resume the download beginning with that file at a later time by selecting **Library> Install Core Content**.

## DOWNLOAD ERRORS

If any problems occur during the library download process, a dialog box will notify you at the end of the download. Click **Retry Download** to repeat the download and correct any errors or click **Cancel** to discard the downloaded catalog.

---

# Importing Library Catalogs

Chief Architect library files have two different file extensions: **.calib** and **.calibz**. Both files can include any combination of Chief Architect library items; in addition, **.calibz** files are able to save data associated with textures and images. Both file types can be imported into the Chief Architect library.

There are several ways to import a **.calib** or **.calibz** file into the program library:

- Double-click on the file in an operating system window while a plan or layout file is open.
- Drag the file from an operating system window and drop it into the Chief Architect program window.
- Select **Library> Import Library** from the program menu.

Although multiple versions of Chief Architect can be installed on a computer, the operating system will only associate **.calib** and **.calibz** library files with one version. If they are not associated with Chief Architect Premier X15, click the **Associate Files with this Program** button in the Preferences dialog. See *File Management Panel on page 104*.

Note: Library files cannot be imported if no plan or layout file is open, or when a Materials List or Ray Trace view window is active.

### *To import library files into the library*

1. Select **Library> Import Library** to display the Import Library Data dialog.
2. Browse to the **.calib** or **.calibz** file(s) that you want to import and either single or group-select the files so that their names display in the **File Name** field.
  - To select a group of files, click on the first one, hold down the Shift key, then click on another file. The two files plus all files in between are selected.
  - To select multiple files individually, click on one, hold down the Ctrl key, then click on additional files. Only the files you click on are selected.
  - To select all files in the directory, click on one and press Ctrl + A. Only do this if you wish to import all files in the folder.
3. Click the **Open** button.
4. A progress bar will display, telling you the progress of each library data file as it is imported.
5. Once imported, each file will be listed in and selected in the Library Browser tree list. See *Library Content on page 961*.
  - If the catalog is a Bonus or Manufacturer catalog, it will be added to the corresponding library catalog.
  - Otherwise, the catalog's contents will be added to the User Catalog. The catalog's folder structure will be preserved, and if any duplicate objects are found, you will be notified.

When a **.calibz** file is imported into the program, any images or textures saved in it will be copied into the Chief Architect Premier X15 Data\Images and Textures folders for backup purposes. The program will only reference these copies if it cannot locate the files in their original locations. See [Chief Architect Premier Data on page 37](#).

## LIBRARY CATALOG MIGRATION

If you have library catalogs from Chief Architect Premier X5 through X14 installed on your computer, the initial startup of Chief Architect Premier X15 will give you the opportunity to migrate that content into the Version X15 Library.

## LEGACY LIBRARY CONVERSION

You can also import legacy **.calib** and **.calibz** files created in Chief Architect X4, X3, or X2 for use in Version X15 at any time. See [Exporting Library Catalogs on page 972](#).

Note: Library content exported from Chief Architect X3 will not include catalog names. Any subscribed content from Version X3 that has not been downloaded will not be included, either.

In addition, legacy **.alb** files created in Chief Architect Versions X1 and 10 and prior can be converted for use in Version X15. Conversion of legacy **.alb** files from Versions 9 and 8 is not supported.

### *To convert legacy library files*

1. Select **Library > Convert Legacy (.alb) Library Files**.
2. In the Select a Legacy Library File Folder dialog, select one or more **.alb** files that you want to bring in to Chief Architect X15.
3. The selected files' names will display in the **File name:** field.
4. Click the **Open** button to import these legacy library files into the User Catalog.
5. Organize the imported content to suit your needs. See [Organizing the Library on page 967](#).

---

## Adding Library Content

In addition to downloading Chief Architect Content and importing entire catalogs into the library, you can also add a variety of individual objects to the library.

### ADD TO LIBRARY

Nearly any object imported into a plan, converted into a symbol, or placed from the Library Browser can be added to the User Catalog in the library.

- Select one or more objects in your plan and click the **Add to Library**  edit button.
- Check **Add to Library** in the Import 3D Symbol dialog. See [Importing 3D Symbols on page 998](#).
- Check **Add to Library** in the Convert to Symbol dialog. See [Convert to Symbol on page 1002](#).
- Custom Patterns can also be added to the Library when they are created or edited. See [Custom Patterns on page 196](#).

A few objects cannot be added to the library: notably imported pictures, metafiles, and PDF files. With the exception of closed polylines, which are added to the library as Molding Profiles, CAD objects cannot be added to the library either. These objects can be added, though, if they are part of a CAD block. See [CAD Blocks on page 329](#).

Any object created using a drawing tool in Chief Architect will automatically be added to the User Catalog using the name of that tool, whereas a symbol will automatically use the Symbol Name. See *Native Objects vs Symbols on page 971*.

If multiple identical objects are selected when the Add to Library button is clicked, only one instance will be added to the User Catalog.

Once added to the library, objects in the User Catalog can be renamed and edited. See *Renaming Library Items on page 968*.

## ADD TO LIBRARY AS

 Some objects have library items assigned to or inserted into them. Cabinets, for example, have door panels inserted into them and materials assigned to them. You can choose to add the containing object to the library, the inserted or assigned items, or any combination of the two using the **Add to Library As** edit tool. See *Placing Library Objects on page 972*.

### To use Add to Library As

1. Select an object that has another item inserted into it and click the **Add to Library As**  edit button.
2. In the Add to Library As dialog, check the box beside each line item that you would like to add to the User Catalog.

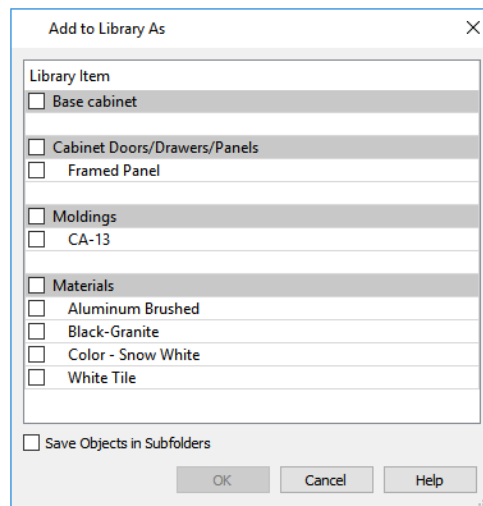

- The top line item is the selected object while those that follow are components of that object.
- Highlighted items are categories that may have multiple components beneath them. Check the box beside a category to add all of its components to the library.
- The line items under each category are components which can be added to the library by checking their boxes individually.
- Check **Save Objects in Subfolders** to create a new folder in the User Catalog in which the selected line items are saved. If the line items are associated with multiple parent objects, a folder is created for each parent and placed in an “Exported Objects” folder in the User Catalog.

## USING THE CONTEXTUAL MENU

A variety of new content can be added to the User Catalog by right-clicking on it or on a folder within it and selecting **New>** from the contextual menu:

- Backdrops - See *3D Backdrops on page 1204*.
- Fill Styles - See *Fill Styles on page 192*.
- Patterns - See *Custom Patterns on page 196*.

- Style Palettes - See *Style Palettes on page 279*.
- Images - See *Images on page 1185*.
- Line Styles - See *Line Style Specification Dialog on page 201*.
- Materials - See *Creating Materials on page 1060*.
- Plant Image - See *Plant Image Specification Dialog on page 1297*.
- 3D Symbols - See *Importing 3D Symbols on page 998*.

See also *Using the Contextual Menu on page 951* and *Adding New Folders on page 967*.

## CREATING A CUSTOMIZED LIBRARY ITEM

You can customize an existing library item and save your changes for future use by first copying the item into the User Catalog.

### *To customize a library object*

1. Right-click on a library item and select **Copy to User Catalog** from the contextual menu.
2. If the library item is already located in the User Catalog, instead select **Duplicate** from the contextual menu.
3. Right-click on the copied item and select **Open Object**  from the menu.
4. The item's specification dialog opens, and you can make any changes that you wish to the item.
5. Make any needed changes to the item, then click OK. Your changes will be saved with this item for use in any plan.

---

## Organizing the Library

Library folders and objects can be copied, pasted, moved, and deleted: allowing you to organize your User Catalog to best suit your work style and needs. See *The User Catalog on page 961*.

### ADDING NEW FOLDERS

New folders can be added to the User Catalog or to any folder located within it. To add a new folder, right-click on User Catalog or one of its sub-folders and select **New> Folder** from the contextual menu. See *Using the Contextual Menu on page 951*.

The new folder is created inside the library item you right-clicked on and is initially named “Untitled”. Right-click on it and select **Rename** from the contextual menu, then type a short, descriptive name and press Enter.

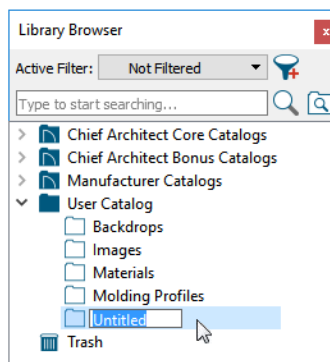

## SELECTING LIBRARY ITEMS

To select a library object, folder, or category, simply click on it in the Folders tree list. You can also multiple-select library items. See *Shift and Ctrl Select on page 214*.

- To select a group of items, click on the first one, hold down the Shift key, then click on another item. The two items plus all items in between are selected.
- To select multiple items individually, click on one, hold down the Ctrl key, then click on additional items. Only the items you click on are selected.

When an object is selected, a thumbnail displays in the Filter Results and Preview panels and basic information about it also displays in the program's Status Bar. See *The Status Bar on page 24*.

A selected library item can be modified in a number of ways to help meet your organizational needs. When multiple items are selected, these options may be limited depending on the specific selection set.

## RENAMING LIBRARY ITEMS

Only folders and objects in the User Catalog can be renamed. There are several ways to do this in the tree list:

- Right-click on the item, select **Rename** from the contextual menu, and type a new name.
- Click once on the item, press F2 on your keyboard and type a new name.
- Click once on the item, pause for a moment, then click a second time and type a new name. You can change this behavior in the Preferences dialog. See *Library Browser Panel on page 100*.

Library names are case-sensitive. While you can have more than one library item that uses the same name, it is best to use short, descriptive and unique names. Some objects, notably CAD blocks, must have unique names and will have numbers appended to their names if different blocks with the same name are placed in a plan.

When an object's name is changed in the User Catalog, its name is also changed in its specification dialog.

## MOVING LIBRARY ITEMS

Folders and objects in the User Catalog can be moved to new locations within the User Catalog. There are several ways to do this:

- Select one or more items in the Folders tree list, then click and drag it to the new location in the list. An icon that follows the mouse pointer indicates when it is over supported and unsupported locations, and any folder able to accept the new content highlights as your mouse pointer moves over it. Release the mouse button to relocate the selection in the highlighted location.
- **Cut** one or more selected items from their current location, right-click on the folder where you want to move them, and **Paste** them there. Cut is found in the selected items' contextual menu while Paste is found in the contextual menu for the destination folder. See *Cut, Copy, and Paste on page 168*.
- Using **Move to Folder**, which is available in the contextual menu for library objects, but not for folders. See *Using the Contextual Menu on page 951*.

Folders and library objects are always organized alphabetically within each hierarchy.

## COPYING AND LINKING LIBRARY ITEMS

All library folders and objects can be copied and pasted to new locations in the User Catalog using options in their contextual menus. There are two types of copies in the library:



- Independent copies of objects that can then be customized without affecting the original. Both folders and objects can be copied to the User Catalog.
- Linked copies, which are actually representations of the same object shown in different locations in the User Catalog. If one copy is edited, all linked copies are affected. Only library objects can have linked copies: folders cannot.

There are two ways to create independent copies of folders and/or objects:

- **Copy** one or more selected folders and/or objects in their current location, right-click on the User Catalog or the subfolder where you want to copy them, and **Paste** them there. Copy is found in the selected items' contextual menu while Paste is found in the contextual menu for the destination folder. See *Cut, Copy, and Paste on page 168*.
- **Copy to User Catalog** pastes copies of the selected object(s) in the User Catalog automatically, without requiring you to choose the location or the Paste command. Not available for folders.

There are also two ways to create linked copies of objects in the User Catalog:

- **Copy** copies a selected object or objects to the system Clipboard. Right-click on the User Catalog or the subfolder where you want to want a linked copy and select **Paste Link** from the contextual menu.
- **Move to Folder** allows you to select multiple folders to list a selected object or objects in.

### MOVE TO FOLDER(S) DIALOG

The Move to Folder(s) dialog allows you to specify which User Catalog folder(s) a selected object or group of objects is listed in. When multiple folders are selected, linked copies of the selected object(s) are created.

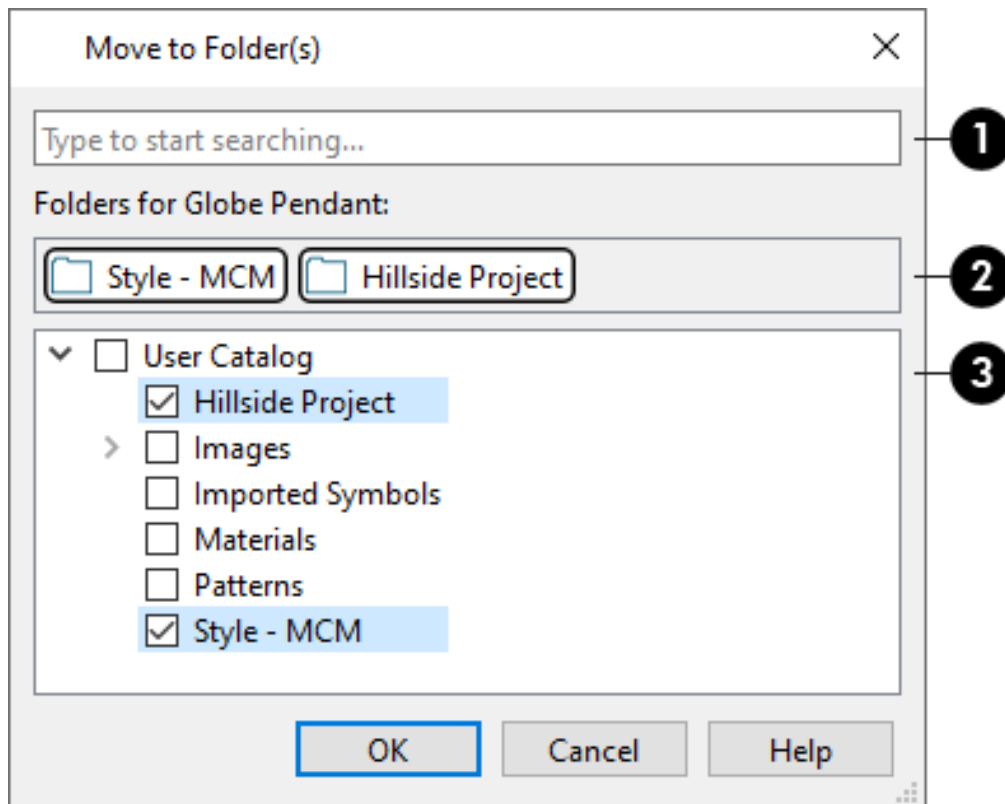

## 1 Search

If your User Catalog contains many folder or subfolders, you can type in this field to search for a particular folder name. A drop-down list of search results will appear below the field that updates as you type: click on an item in that list to select it.

## 2 Folders for Item/Common Folders for Items

The names of folders the selected object(s) are listed in are reported here.

- When multiple objects are selected, only the folders that all objects are listed in will be named here.
- Click on a name to remove the selected object(s) from that folder.

## 3 User Catalog Folders

The names of all folders and subfolders in the User Catalog are listed here.

- Check the box beside the User Catalog, a folder, or a subfolder to list the selected objects in that location.

## DELETING LIBRARY ITEMS

The five installed library categories: Chief Architect Core Catalogs, Chief Architect Bonus Catalogs, Manufacturer Catalogs, User Catalog, and Trash cannot be deleted.

Catalog level folders in all categories can be deleted; however, individual subfolders and objects can only be deleted out of the User Catalog.

Items in the library that are eligible for deletion can be deleted in either of two ways:

- Right-click on it and choose **Delete** from the contextual menu.
- Select it and press the **Delete** key on your keyboard.

When items from the User Catalog are deleted, they are moved to the Library Browser Trash . Items in the Trash can be retrieved by right-clicking on them and selecting **Restore** from the contextual menu.

To empty the Trash, right-click on it and select **Empty Trash** from the contextual menu.

Depending on how much content is in the Trash, emptying it can be time consuming. You can click the **Cancel** button to end the process if you wish.

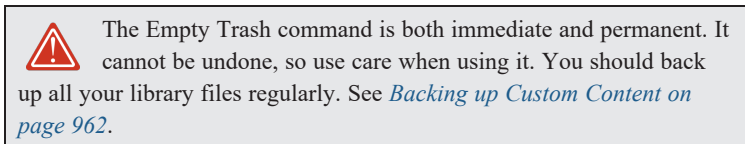

When content is deleted from the Library Browser, data associated with that content may remain in the library database. If you delete library content for the purpose of increasing available disk space, you can right-click on the User Catalog as well as the Trash and select **Vacuum** from the contextual menu. See [The Library Browser on page 946](#).

---



## Editing Library Objects

The Core, Manufacturer, and Bonus Catalogs and the objects within them cannot be edited. Library objects can, however, be customized to suit your design needs. There are three approaches to doing so:

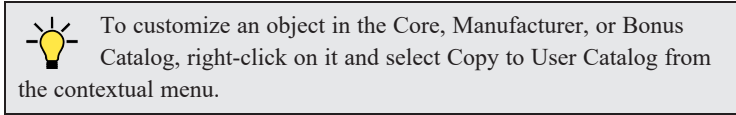
- Select an object in the User Catalog, edit it using any of the options in its contextual menu, and your changes will be reflected when you next place this library object in a drawing. See [Using the Contextual Menu on page 951](#).
- Place an object in a drawing and then edit it using the various edit tools available for it. This will not affect the original object still saved in the library.
- Place an object in a drawing, edit it using the available edit tools, and then add it back to the library for future use. This will not replace the original object still saved in the library. See [Add to Library on page 965](#).



## NATIVE OBJECTS VS SYMBOLS

In Chief Architect, objects created using the program's standard tools, such as the **Door Tools**  and **Cabinet Tools** , are referred to as native objects.

On the other hand, objects placed from the library, such as fixtures and furnishings, are symbols. Symbols are typically more limited than native objects in how they can be edited.



In addition to the symbols available in the library, you can import additional symbols into the program from 3D **.dxf**, **.dwg**, **.obj**, **.3ds**, **.skp**, or **.dae** files. See [Importing 3D Symbols on page 998](#).

Any changes made to objects like fixtures and furniture will not be reflected in their Materials List Description, although they may be seen in other columns, such as Size. See [Materials Lists on page 1303](#).

You can change a symbol's name, which is used in its Materials List Description, in the Symbol Specification dialog. You can also change the names of its components. See [3D Panel on page 990](#) and [Materials Panel on page 997](#).

## USING THE EDIT TOOLS

In addition, items saved in the User Catalog can be edited. If you right-click on a line item in the Library Browser Directory Pane, one or more edit tools may be available in the contextual menu:

-  Right-click on the name of an individual symbol, Text or Rich Text object, Callout, Marker, Note, Elevation Point, image, or plant image and select **Open Object** to open that item's specification dialog. Open Object is also available for multiple selected items of the same type. See [Specification Dialogs on page 21](#).
-  Right-click on the name of a cabinet with a fixture inserted in its top and select **Open Symbol** to open that item's Symbol Specification dialog. See [Symbol Object Specification Dialogs on page 986](#).
-  Right-click on the name of a CAD block or a symbol object represented by a CAD Block in plan view and select **Edit CAD Block** to open a CAD Block Window where that block can be edited. See [Edit CAD Block on page 330](#).

Individual or multiple group-selected materials can be edited by right-clicking and selecting **Open Object** as well. See [Define Material Dialog on page 1066](#).

## EDITING BUILT-IN FIXTURES AND APPLIANCES

A fixture inserted into the top of a cabinet can be selected by clicking on it, then clicking the **Select Next Object**  edit tool. See [Select Next Object on page 211](#).

In addition, items saved in the User Catalog can be edited. If you right-click on a line item in the Library Browser Directory Pane, one or more edit tools may be available in the contextual menu:



Select **Open Object** to open the cabinet's specification dialog. See *Cabinet Specification Dialog on page 643*.



Select **Open Symbol** to open the fixture's Symbol Specification dialog. See *Symbol Object Specification Dialogs on page 986*.

A fixture installed into the front of a cabinet becomes a cabinet face item, like a door or drawer. It can be resized or deleted like other face items in the Cabinet Specification dialog. See *Front/Sides/Back Panel on page 648*.

## SEARCH ATTRIBUTES

Objects in the library all have one or more search attributes, which are keywords and architectural styles that can be used to find them in a library search. The Search Attributes dialog lists these attributes for each library object. See *Search Attributes on page 959*.

---

# Exporting Library Catalogs

Exporting library files allows you to:

- Back up your custom library content.
- Transfer library content between computers.
- Share custom library content with colleagues.

Exporting is often preferable to simply copying library files because it allows you to include images and textures in the exported library.

### *To export content from the library*

1. Locate an object, folder, or catalog that you want to export, right click on it, and select **Export Library**.
2. In the Export Library Data dialog:
  - Choose the appropriate **Save in:** location for your exported library file.
  - Type a short, descriptive name for your library file in the **File Name** field.
  - Click the **Save as type:** drop-down list and select whether or not you want the library to include Textures/Images.



If any of the items being exported are images or use textures, be sure to select the .calibz file type.

- Click **Save**.
3. Your exported library file can now be copied to a network location or storage device in an operating system window.

---

# Placing Library Objects

Library objects are subject to placement restrictions based upon typical real-life placement. Most library objects require sufficient free space at the location where they are placed, for example, and some library objects have additional requirements. Library windows and doors, for example, must be placed in a wall just like standard windows and doors, and some fixtures are designed to be placed in cabinets.

Library symbols have placement restrictions that are determined when the symbol is created but can be changed later. See *Native Objects vs Symbols on page 971* and *Symbol Object Specification Dialogs on page 986*.

There are three main categories of items available in the Library Browser:

- Stand-alone objects that can be placed directly into a plan. Examples include cabinet modules, furnishings and images.
- 3D objects designed to be inserted into another 3D object. Examples include cabinet fixtures, windows and doors. Some items, such as cabinet doors, railing balusters, and fence panels, can be inserted into another object or placed as stand-alone objects.
- Materials, line styles, fill styles, and molding profiles, which cannot stand alone and must be assigned or applied to another object.

If a warning message displays when placing a library object or symbol, it will indicate where the object can be placed.

## STAND-ALONE OBJECTS

Most library categories contain objects that can be selected in the Library Browser and placed directly in a 2D or 3D view.

- Most stand-alone objects are designed to rest on the floor or terrain.
- Some objects will rest on top of a cabinet or countertop, shelf, furniture, or roof plane object if one is located at the point where they are first placed.
- A few objects, notably some light fixtures, will mount on the bottom of a wall cabinet or on the ceiling.
- In addition, some objects will attach to a wall if one is nearby.

### ***To place a stand-alone library object***

1. Click on an object in the Folders tree list or Filter Results list in the Library Browser to select it for placement. See [The Library Browser on page 946](#).
2. Move your mouse pointer into the view area and notice that it displays an icon indicating the type of object selected instead of an arrow.
3. Click to place the selected object at that location.
4. Continue clicking to place as many instances of the selected object as needed. When you are finished, click the **Select Objects**  button.

Once a stand-alone object has been placed, it can be edited in a variety of ways. See [Editing Library Objects on page 970](#).

## INSERTED OBJECTS

Some objects cannot stand alone and must be placed into other objects in a plan. For example, doors and windows must be inserted into a wall, while some appliances and plumbing fixtures are designed to be placed inside a base cabinet. See [Doors on page 543](#), [Windows on page 576](#) and [Cabinets on page 617](#).

With the exceptions of doors, windows, and skylights, an inserted library object can only display in a 2D or 3D view if the object that contains it is set to display. This is the case even if the inserted object's layer is turned on. See [Displaying Symbol Objects on page 979](#).

### ***To insert a library object***

1. Click on an item in the Folders tree list or Filter Results list of the Library Browser to select it for placement. See [The Library Browser on page 946](#).
2. Move your pointer into the drawing area.
3. Click on the object into which you wish to insert the selected library item. If the selected library item is designed to be inserted into that type of object, it will be placed into it.

- Continue clicking on other objects to place as many instances of the selected item as needed. When you are finished, click the **Select Objects**  button.

When an object has been inserted into another object, it can be replaced directly from the library. See [Replace From Library on page 976](#).

If you try to insert an object into another object that is on a locked layer, nothing will be created. See [Object Creation and Layers on page 167](#).

## ASSIGNED ITEMS

Some library items, such as line styles, fill styles, materials and moldings, are not objects in themselves but can be applied to objects in a variety of ways.

- Using the specification dialog of the containing object. See [Select Library Object Dialog on page 974](#).
- By selecting the item in the library and then clicking on the containing object.
- Fill styles, materials and moldings can be assigned to objects directly from the library in 3D views by selecting the library item and then clicking on an object. See [Eyedropper and Painter Tools on page 277](#) and [Replace From Library on page 976](#).
- An entire collection of properties can be applied to multiple objects by selecting a Style Palette in the library and then clicking on an eligible object. See [Style Palettes on page 279](#).
- Moldings and line styles can also be added to a plan by selecting the desired library item, then clicking and dragging a line in the drawing area. The result is either a Molding Line or CAD Line, depending on the selected library item. See [Molding Polylines on page 935](#) and [Line Styles on page 199](#).

## PLACE LIBRARY OBJECT BUTTON

 The **Place Library Object** button can be added to your toolbar and used for quick access and placement of frequently used library items. See [Place Library Object Button on page 975](#).

Once a library object has been assigned, click the button and then click in a view to place or apply the assigned item.

---

## Select Library Object Dialog

The Select Library Object dialog is a modal version of the Library Browser that is accessible from many object specification dialogs. See [Specification Dialogs on page 21](#).

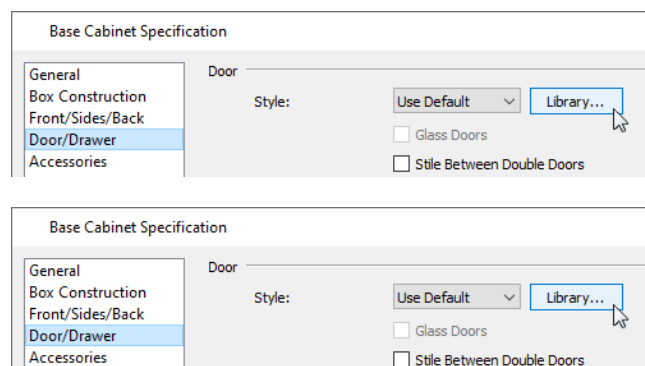

This dialog also opens when you select the **Fill Style Painter**  tool. See [Painter Tools on page 278](#).

The Select Library Object dialog only displays categories of items that are related to the object component being edited. For example, if this dialog is accessed from the DOOR/DRAWER panel of the Cabinet Specification dialog, only cabinet door and drawer symbols will be listed. If it is accessed from the Moldings panel, only moldings will be listed.

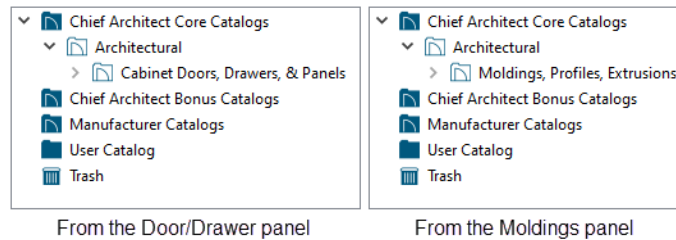

The Select Library Object dialog is similar to the LIBRARY MATERIALS panel of the Select Material dialog. See [Select Material/Library Object Dialog on page 1056](#).

## Place Library Object Button

 The **Place Library Object** button can be added to your toolbar and used for quick access and placement of frequently used library items.

If the **Place Library Object** button has not yet been assigned a library object, click it once to open the Library Object Button Specification dialog.

Double-click a **Place Library Object** button that has been assigned a library object to open the Library Object Button Specification dialog.

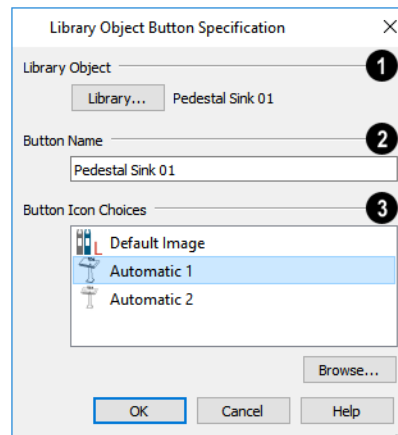

### 1 Library Object

Click the **Library** button to open the Select Library Object dialog and assign a library object to the button. If a library object has already been assigned, click this button to assign a new library object. See [Select Library Object Dialog on page 974](#).

### 2 Button Name

When a library object has been selected, type a **Button Name** in the text field.

### 3 Button Icon Choices

When a library object has been selected, assign a **Button Icon**. Choose from two automatically generated button icons or click **Browse** to browse your computer for a different icon.

Up to 398 **Place Library Object** buttons can be added to the same toolbar, each assigned a different object.

The library object assigned to the **Place Library Object** button is actually saved with that particular button. If you move or delete the library item from the library, the button will continue to function.







---

## Replace From Library

There are two different ways to replace an object in a plan with another object from the library.

An inserted object or a molding profile can be replaced by a different item from the library with a single click. This approach is particularly effective in 3D views, where the results can immediately be seen. See *Inserted Objects on page 973*.

### To replace an inserted object

1. Open the Library Browser, browse to an object of a type similar to the one you wish to replace, and click on it to select it.
2. Select a Replace from Library Scoping Mode from the Edit Toolbar:
  - **Component Mode**  is the default mode and replaces a single instance of a molding or an inserted object on the target object. Most object types have a list of components in their specification dialog, on the MATERIALS panel. See *Materials Panel on page 1055*.
  - **Object Mode**  replaces all instances of an item inserted into the target object.
  - **Room Mode**  replaces all instances of an item inserted into objects in the room where the target object is located.
  - **Floor Mode**  replaces all instances of an item inserted into objects on the floor where the target object is located.
  - **Plan Mode**  replaces all instances of an item inserted into objects in the entire plan.
  - **Toggle Library Replacement Mode**  allows you to place a free-standing object instead of replacing anything.
3. Move the mouse pointer into the view window. The Replace from Library  icon will display near the mouse pointer when it passes over an object that can be replaced by the selection from the library.
4. Click once to replace the object in the plan as well as to any other identical objects, depending on which Painter Scoping Mode is active, with the selected object from the library.

Some types of inserted objects - notably, plants assigned to Garden Beds, cabinet doors and drawers, and doors - can also be replaced in this manner in plan view provided that the Alternate Edit Behavior is not active. The Replace from Library  icon does not display in plan view, however.

 In the Windows version of the program, you can temporarily override this replacement behavior in plan view by holding down the Alt key. A free-standing object will be created if there is space for it instead of an inserted object being replaced.



 The **Replace From Library** edit button is available for nearly any stand-alone object that can be added to the library and can be used in 2D and 3D views. Click this button to open the Replace From Library dialog and replace the selected object, and others like it if you choose, with an object of the same type from the library.

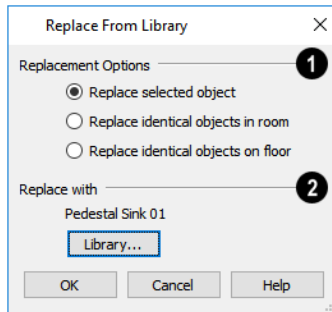



## 1 Replacement Options

- **Replace Selected Object** replaces only the currently selected object.
- **Replace Identical Objects in Room** replaces all objects that are in the same room as, and are identical to, the currently selected object. Not available for doors or windows.
- **Replace Identical Objects on Floor** replaces all objects that are on the same floor as, and are identical to, the currently selected object.

## 2 Replace With

Click the **Library** button to open the Select Library Object dialog and select an object to use as a replacement. The name of the object that is currently selected as a replacement displays above.

**Replace From Library**  cannot be used to replace a selected wall or a selected cabinet with a cabinet of a larger size. In addition, it is not available for backdrops and items assigned to other objects, such as materials.

 If the Replace from Library edit tool is used to replace an electrical object, any Connect Electrical splines attached to it will be deleted. See [Connect Electrical on page 671](#).

# Symbol Objects

## Chapter 28

Symbol objects play a variety of important roles in Chief Architect.

Chief Architect provides a complete set of architectural tools for creating highly customized designs, as well as a large selection of objects in the Library Browser that can be used to add more detail to a plan.

In addition, if you don't find precisely what you need, you can either import symbols from third party sources or create your own symbols in Chief Architect. See *Importing 3D Symbols on page 998*.

Custom symbols can also be edited and added to the library. See *The Library on page 945*.

### TOPICS

<b>Displaying Symbol Objects</b> .....	<b>979</b>
<b>Editing Symbol Objects</b> .....	<b>980</b>
<b>Symbol Object Specification Dialogs</b> .....	<b>986</b>
<b>Importing 3D Symbols</b> .....	<b>998</b>
<b>3D Data Import Requirements</b> .....	<b>999</b>
<b>3D Symbols and Materials</b> .....	<b>1000</b>
<b>Get Last Symbol</b> .....	<b>1002</b>
<b>Convert to Symbol</b> .....	<b>1002</b>
<b>Symbol Categories</b> .....	<b>1003</b>
<b>Exporting a 3D Model</b> .....	<b>1004</b>

---

## Displaying Symbol Objects

The display options available for symbol objects depend on the type of object in question, as well as the view.

If the display of an object is turned off in a 2D or 3D view, any objects inserted into it will not display in that view, either - even if the inserted object's layer is turned on. See *Inserted Objects on page 973*.

### IN PLAN VIEW

All symbol objects except doors and drawers applied to cabinets and hardware applied to doors or cabinets can display in plan view. Symbol objects are represented in plan view by 2D CAD Blocks that resemble the size and shape of the object when viewed from above. The CAD Block representing a symbol object can be specified in the Symbol Specification dialog. See *2D Block Panel on page 993*.

As with other architectural objects, the display of symbol objects is controlled by layer in the Layer Display Options dialog. Each category of objects has its own layer. See *Layer Display Options Dialog on page 179*.

Like other objects, each symbol object is placed in a Drawing Group that affects whether it displays in front of or behind other objects. You can modify a selected symbol's place in the drawing order by clicking the **View Drawing Group Edit Tools**  edit button. See *Drawing Group Edit Tools on page 190*.

### OBJECT LABELS

Free-standing symbol objects, including those in Architectural Blocks, can display labels in plan and cross section/elevation views when the appropriate layer is set to display in the Layer Display Options dialog. Fixture labels, for example, are located on the "Fixtures, Labels" layer. See *Label Panel on page 700*.

Object labels have their own edit handles and can be moved and rotated when the object is selected. Library object labels use the Text Style assigned to their layer. See *Text Styles on page 538*.

You can specify a custom label for symbol objects in their specification dialog. See *Symbol Object Specification Dialogs on page 986*.

### IN 3D VIEWS

All symbol objects can display in 3D views when their layers are turned on.

### IN THE MATERIALS LIST

Most objects placed from the library are counted in the Materials List. These architectural objects have a COMPONENTS panel in their specification dialog that lets you control how that object displays in the Materials List. See *Components Panel on page 1330*.

Note: Although the size and materials of many library objects can be edited, these changes are not reflected in the Materials List. See *Materials Lists on page 1303*.

Some library items such as CAD blocks, line styles, and backdrops do not display in the Materials List.

## FIXTURE AND FURNISHING SCHEDULES



The **Fixture** and **Furnishing Schedule** tools allow you to produce customizable fixture and furnishing schedules as well as fixture and furnishing labels that display schedule numbers. See *The Schedule Tools on page 682*.

Although not all symbol object types have a schedule tool, they can be included in schedules, as well. See *Schedule Panel on page 704*.

Schedules can be customized for specific purposes: for example, to create appliance, plumbing, or HVAC schedules. See *Working with Multiple Schedules on page 691*.

The fixtures or furnishings located in an individual room can be listed in their own schedule. See *Create Schedule from Room on page 683*.

---

## Editing Symbol Objects

Symbol objects can be selected and edited much like other objects in the program. A symbol's category determines exactly what editing options are available; however, most symbols can be edited using the edit handles, edit toolbar, and specification dialog. See *Editing Objects on page 205*.

Symbols have some additional options that allow you to control how the symbol behaves when it is placed, selected, moved and resized.

Stand-alone library symbols placed in a plan can be selected individually or as a group, like other objects in Chief Architect. To select a symbol object inserted into the top of a cabinet, select that cabinet and click the **Select Next Object**  edit button. See *Selecting Objects on page 210*.

Once selected, a library object can be edited in a variety of ways using dimensions, the edit handles, the Edit Toolbar buttons and its specification dialog. See *Symbol Object Specification Dialogs on page 986*.

A selected library object placed in a plan will have a variety of edit tools available. See *The Edit Toolbar on page 130*.

## NATIVE OBJECTS VS SYMBOLS

In Chief Architect, objects created using the program's standard tools, such as the **Door Tools**  and **Cabinet Tools** , are referred to as native objects.

On the other hand, objects placed from the library, such as fixtures and furnishings, are symbols. Symbols are typically more limited than native objects in how they can be edited.

In addition to the symbols available in the library, you can import additional symbols into the program from 3D **.dxf**, **.dwg**, **.obj**, **.3ds**, **.skp**, or **.dae** files. See *Importing 3D Symbols on page 998*.

Any changes made to objects like fixtures and furniture will not be reflected in their Materials List Description, although they may be seen in other columns, such as Size. See *Materials Lists on page 1303*.

You can change a symbol's name, which is used in its Materials List Description, in the Symbol Specification dialog. You can also change the names of its components. See *3D Panel on page 990* and *Materials Panel on page 997*.

## USING EDIT HANDLES

Most free-standing library symbols are box-based objects and can be edited as such once placed in a drawing. See *Editing Box-Based Objects on page 232*. Depending on the type of view and the surface selected, the edit handles a symbol displays

will vary.

When a typical symbol is selected in plan view or on the top surface in a 3D view, up to ten edit handles display. They are the Move handle at the center, the Rotate handle just outside the front indicator (a V) and a Resize handle on each edge and at each corner. In plan view, symbol object labels also have a small square Move edit handle and small rectangular Rotate handle.

If the selected symbol object has a Stretch Plane defined and you resize it using its edit handles in plan view, the program will give you an opportunity to generate a new 2D CAD Block for it. See [Stretch Planes and Zones on page 983](#).

When a symbol is selected on a side in a cross section/elevation or 3D view, it displays six edit handles: the Move handle, a Rotate handle, and a Resize handle on each edge. See [Selected Side on page 213](#) and [Rotating Symbols on page 985](#).

When a free-standing symbol is selected on its side and rotated, you will be prompted to choose whether to update its plan view symbol to reflect its new orientation, as viewed from above. See [In Plan View on page 979](#).

Symbols cannot be concentrically resized, even when the **Concentric**  edit behavior is enabled. See [Defaults, Preferences, and Edit Behaviors on page 206](#).

The labels of library objects, when displayed, have a separate Move edit handle that displays when the object is selected. See [Label Panel on page 700](#).

Fixtures and furniture placed in a plan are subject to bumping/pushing behavior when moved. See [Bumping/Pushing on page 243](#).

## EDITING BUILT-IN FIXTURES AND APPLIANCES

A fixture symbol inserted into the top of a cabinet can be selected by clicking on it, then clicking the **Select Next Object**  edit tool. Once selected, the fixture can be moved, rotated, and resized using its edit handles. See [Inserted Objects on page 973](#) and [Select Next Object on page 211](#).

The specification dialog for a fixture symbol inserted into a cabinet can be accessed in either of two ways:



With the fixture selected, click the **Open Object** edit button to open its specification dialog.



Select the cabinet and click the **Open Symbol** edit button to open the fixture's Symbol Object Specification dialog.

A fixture installed into the front of a cabinet becomes a cabinet face item, like a door or drawer. It can be resized or deleted like other face items in the Cabinet Specification dialog. See [Front/Sides/Back Panel on page 648](#).

## SYMBOL ORIGIN

All symbols have an origin point, which determines how the object is positioned when it is placed in a plan. The origin point also determines the location of a symbol's bounding box and 2D block.

The location of a symbol's origin point is typically on its back surface, at the bottom center; however, this may vary, depending on the symbol's category. You can see the location of a selected symbol's origin in preview pane of the Symbol Object Specification dialog. See [3D Panel on page 990](#).

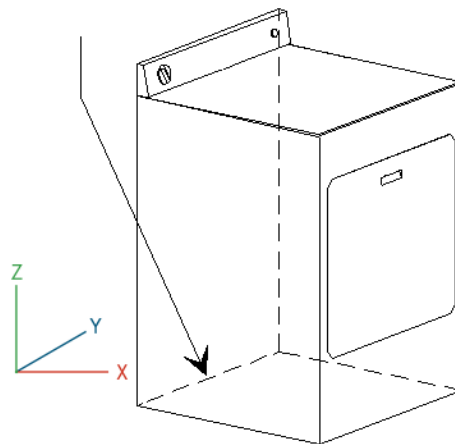

The following table lists these default origins by symbol type:

Symbol Type	Origin location
<b>Cabinet (legacy)</b>	Bottom, Back, Center
<b>Cabinet Door</b>	Bottom, Back, Center
<b>Doors</b>	Bottom, Back, Center
<b>Doorways</b>	Bottom, Outside, Center
<b>Electrical, Ceiling Mounted</b>	Center Top
<b>Electrical, Wall Mounted</b>	Back, Center
<b>Electrical, Floor Mounted</b>	Center, Bottom
<b>Electrical, Wall Mounted</b>	Center, Back
<b>Furniture</b>	Bottom, Back, Center
<b>Fixture</b>	Bottom, Back, Center
<b>Geometric Shapes</b>	Bottom, Back, Center
<b>Hardware</b>	Bottom, Back, Center
<b>Millwork</b>	Bottom, Back, Center
<b>Molding</b>	N/A
<b>Plant</b>	Bottom, Back, Center
<b>Sprinkler</b>	Back, Center; Height varies
<b>Windows</b>	Bottom, Exterior, Center of sill

You can offset a symbol from its origin point. This can make it easy to insert the object inside another object, but does not affect the location of the bounding box or the 2D block that displays in plan view.

### ***To create an insertable symbol***

1. Make a note of the symbol's actual size on the GENERAL panel of its specification dialog.
2. Click the **Open Symbol**  edit button to open the Symbol Specification dialog.
3. On the 3D panel, check **Specify Origin**.
4. Adjust the **X**, **Y** and/or **Z** values as needed:
  - To insert the back of the symbol into the side of another object at a particular distance, specify that distance in the **Y** field as a positive value.
  - To insert the bottom of the symbol into the top of another object, specify the distance that it should be dropped as a negative value in the **Z** field.

## **BOUNDING BOXES**

An object's bounding box determines the amount of space it requires in 3D and thus how close it can be moved to other objects before it bumps into them. For most symbol objects, the bounding box corresponds to the extents of the object's geometry. Some objects have an enlarged bounding box to create required clearances.

The bounding box also defines the selectable area around a symbol: when you click within an object's bounding box, it will become selected. Similarly, the bounding box affects whether an object is included in a selection marquee. See [Selecting Objects on page 210](#).

When a symbol is selected, its edit handles display around the perimeter of its bounding box. See [Edit Handles on page 23](#).

You can create setback space for a symbol by increasing its bounding box size on the SIZING panel of the Symbol Specification dialog. See [Sizing Panel on page 988](#).

### ***To create setback space for a symbol***

1. Make a note of the symbol's actual size on the GENERAL panel of its specification dialog.
2. Select a symbol object and click the **Open Symbol**  edit button to open the Symbol Specification dialog.
3. On the SIZING panel, click the **Show Advanced Controls** button.
4. Increase the **Bounding Box Spacing** values by the amount of the desired setback space.

You can also allow a symbol to set into another object by reducing its bounding box size. Unlike the symbol itself, the bounding box and 2D block cannot be offset from the origin.

## **STRETCH PLANES AND ZONES**

Stretch Planes and Stretch Zones define where a symbol stretches when resized.

If a symbol has no Stretch Planes or Zones, its surfaces will all resize uniformly; if, on the other hand, a Stretch Plane or Zone is defined, the object will resize only within the plane or zone. Any portions of the symbol located outside the plane or zone will not resize at all.

- A Stretch Plane is a two dimensional plane within a symbol which increases or decreases in thickness as the symbol is resized.
- A Stretch Zone defines an area between two Stretch Planes that resizes uniformly, leaving the area outside unaffected.

Stretch Plane coordinates are relative to the symbol's origin point. For many object types, the origin is located at the bottom center of its back surface.

 When one or more Stretch Planes are specified and the symbol is resized using its edit handles in plan view, the program will present you with the option of updating its 2D CAD Block. See [2D Block Panel on page 993](#).

**To define a Width stretch plane**

1. Open a symbol’s Symbol Specification dialog using any of the available methods. See [Symbol Object Specification Dialogs on page 986](#).
2. On the SIZING panel, under the Stretch Planes heading, check the box beside **1** to the left of the **Width** column. The field to its right becomes active.
3. The new plane has an initial value of 0.
  - Leave it at 0” to run the plane through the object’s default origin point.
  - Specify a negative number to define a plane to the left of the origin.
  - Specify a positive number to define a plane to the right of the origin.
4. Click **OK**. When the symbol’s width is changed, only the cross section defined by the Stretch Plane will be affected.

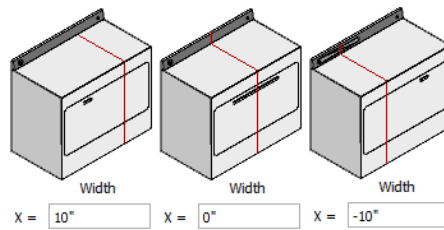

**To define a Depth or Height stretch plane**

1. On the SIZING panel of the Symbol Object Specification dialogs, under the Stretch Planes heading, check the box beside **1** to the left either the **Depth** or **Height** column. The field to its right becomes active.
2. The new plane has an initial value of 0.
  - To define a Height stretch plane, specify a positive number between 0 and the overall height of the symbol.
  - To define a Depth stretch plane, specify a negative number.
3. Click **OK**. When the symbol’s depth or height is changed, only the cross section defined by the Stretch Plane will be affected.

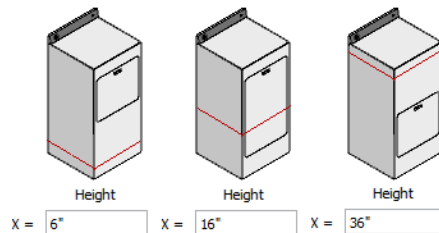

A symbol can have up to three Stretch Planes in each direction, for a total of nine.



### ***To define two stretch planes***

1. Open a symbol's Symbol Object Specification dialog.
2. On the SIZING panel, check the boxes beside **1** and **2** to the left of a column under Stretch Planes. The fields to their right becomes active.
3. Specify the desired values to define each Stretch Plane within the symbol.
4. Click **OK**. When the symbol is resized, the two cross sections defined by the Stretch Plane will be affected.

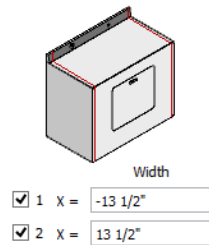

### ***To define a stretch zone***

1. Open a symbol's Symbol Specification dialog.
2. On the SIZING panel, under the Stretch Planes heading, check the boxes beside **1** and **2** to the left of a column under Stretch Planes. The fields to their right becomes active.
3. Specify values for both planes.
4. Check the box beside the corresponding option in the Stretch Zones section of the panel.
5. Click **OK**. When the symbol is resized, only the area within the Stretch Zone will be affected.

## **ROTATING SYMBOLS**

Symbol objects can be rotated in all three dimensions in the Symbol Object Specification dialog. Free-standing symbols can also be rotated in 3D views using the Rotate edit handle: select the symbol on different surfaces to rotate it along its different axes. See [Selected Side on page 213](#).

In either case, the symbol's bounding box will not rotate with the symbol's geometry. Instead, it will resize as needed to contain the symbol's surfaces and its sides will remain orthogonal to the X, Y, and Z axes in the drawing space. See [3D Drafting on page 13](#).

Similarly, the symbol origin will not rotate with the symbol geometry. Instead, its position on the bounding box will remain constant and its position relative to the symbol's surfaces will change.

In contrast, stretch zones and planes do rotate with the symbol's geometry, so if a symbol is rotated and then resized, it will stretch appropriately rather than become misshapen.

When a symbol is rotated in 3D, its 2D representation in plan view may need to change. The first time you rotate a symbol, the program will ask if you want the 2D plan view symbol to be regenerated to reflect its new orientation. If you click Yes, it will be automatically regenerated every time you rotate it. You can enable or disable **Auto Generate** in the Symbol Object Specification dialog. See [2D Block Panel on page 993](#).

## **EDIT WALL CUTOUT POLYLINE**



The **Edit Wall Cutout Polyline** edit tool is available in camera views when a selected symbol has **Inserts into Wall** checked in the Symbol Specification dialog. See [Options Panel on page 994](#).

Click this button to enable edit handles on the symbol's wall cutout polyline so that its shape can be edited. See [Editing Closed Polyline-Based Objects on page 228](#).

To restore the original shape of the cutout polyline, click the **Reset Wall Cutout Polyline**  edit button while the cutout polyline is active for editing.

---

## Symbol Object Specification Dialogs





 Select a symbol object and click the **Open Object** edit button to open that object's Symbol Object Specification dialog. This dialog can also be opened when multiple symbol objects are selected as long as the objects are of the same type.

The names of these dialogs vary and are determined by the type of object being edited:

- Electrical Service Specification
- Fixture Specification
- Furniture Specification
- Geometric Shape Specification
- Hardware Specification
- Millwork Specification
- Plant Specification
- Sprinkler Specification
- Symbol Specification dialog for Window Symbols

The panels that are available in this dialog depend on the Category that the selected symbol is assigned to.

There are a number of other ways to access these dialogs:

- Right-click on a symbol object in the library User Catalog and select **Open Object** . Editing a symbol in the library changes does not affect any instances of the symbol already placed in a plan. Legacy cabinet symbols cannot be edited in this manner. See [Editing Library Objects on page 970](#).
- Select a base cabinet with a fixture symbol inserted into its top and click the **Open Symbol**  edit button. See [Inserted Objects on page 973](#).
- Select a Window Symbol and click the **Open Symbol**  edit button. See [Window Symbols on page 581](#).
- Click the Appliance/Door/Drawer **Edit** button in the specification dialog for a cabinet with a fixture symbol inserted into its front. See [Front/Sides/Back Panel on page 648](#).
- Click the **Edit** button in the Electrical Defaults dialog. See [Electrical Defaults on page 667](#).
- Select a schedule row that lists a symbol object and click the **Open Row Object(s)**  edit button. See [Open Row Object\(s\) on page 686](#).
- Check **Show Advanced Options** in the Import 3D Symbol dialog. Editing a symbol as it is imported determines the initial attributes that it will have once brought into a plan or saved in the library. See [Importing 3D Symbols on page 998](#).
- Check **Show Advanced Options** in the Convert to Symbol dialog. See [Convert to Symbol on page 1002](#).
- The settings in the Hardware Size/Orientation dialog for cabinet hardware are also found on the GENERAL panel of this dialog. See [Cabinet Hardware on page 638](#).

## GENERAL PANEL

The General panel is not available for Window Symbols.

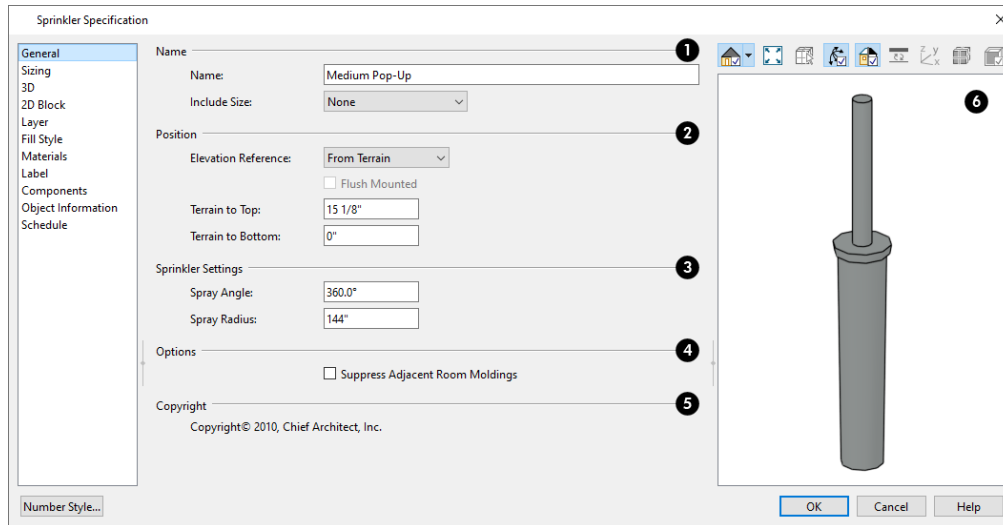

### 1 Name

A symbol object's Name is used in its automatic Description, automatic Label, and when added to the library.

- Specify the selected symbol object's **Name**. When a symbol is imported into the program, it is given the same name as its file name. See [Importing 3D Symbols on page 998](#).
- Select an option from the drop-down list to **Include Size** information along with the Name wherever it is used.

### 2 Position

- Select the **Elevation Reference** from the drop-down list. This determines where the next two settings are measured from and also affects their setting labels. Not available in the Electrical Service Specification or Hardware Size/Orientation dialog. See [Elevation References on page 20](#).
- Specify the height **to Top**, measured from the selected Elevation Reference to the top of the object.
- Specify the height **to Bottom**, measured from the selected Elevation Reference to the bottom of the object.
- The options available for electrical objects differ from other symbol objects, and vary depending on where the selected object is set to be mounted:
  - For Ceiling Mounted objects and those set to Mount Under Wall Cabinet, specify the **Offset from Ceiling**. A negative value recesses the selected object into the surface it is mounted on.
  - For Floor Mounted objects, specify the **Offset from Floor**.
  - For Wall Mounted and Cabinet Mounted objects, specify the **Height to Center**, measured from the object's center to the floor or terrain.
  - For Wall Mounted and Cabinet Mounted objects, you can also specify the symbol's horizontal **Distance from Wall** or **Distance from Cabinet**. A negative value recesses the object into the surface it is mounted on.

### 3 Sprinkler Settings

The **Sprinkler Settings** are only available if the selected object is a sprinkler. See [Sprinkler Tools on page 1301](#).

- Specify the **Spray Angle**, which is the angle within which the sprinkler sprays. An angle of 360° forms a complete circle.
- Specify the **Spray Radius**, which is the distance from the sprinkler head that the spray reaches.

#### 4 Options

Not available in the Electrical Service Specification dialog.

- When **Suppress Adjacent Room Moldings** is checked, room moldings do not generate on walls where the selected object touches them. When it is unchecked, room moldings generate through the object.

#### 5 Copyright

If the selected object has a copyright, information about it displays here.

#### 6 Preview

A preview of the selected library object displays here and updates with changes. If the selected symbol is inserted into another object, such as an appliance in a cabinet, the parent object will also display. See [Dialog Preview Panes on page 22](#).

### SIZING PANEL

The settings on the SIZING panel allow you to control the size of a symbol's bounding box and how the symbol behaves when resized.

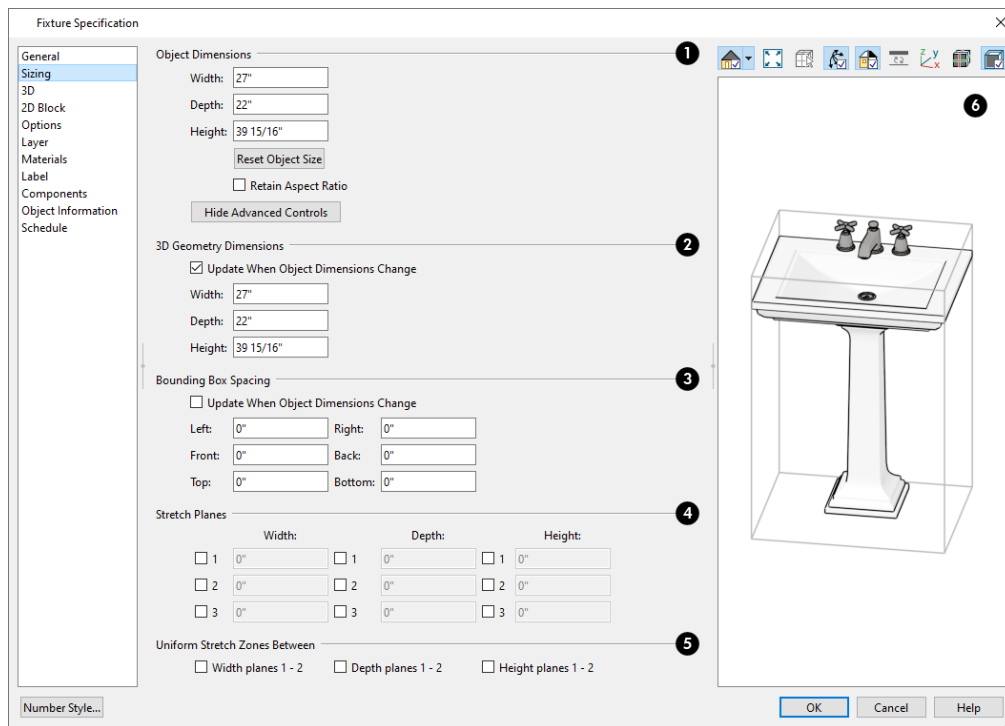

#### 1 Object Dimensions

These values describe the total size of the selected object's bounding box. For some objects, such as those that insert into cabinets or have special clearance requirements, the bounding box will not match the symbol's geometry.

- Specify the total **Width**, **Depth**, and **Height** of the object's bounding box.
- Click the **Reset Object Size** button to reset the original Width, Depth, and Height values.
- When **Retain Aspect Ratio** is unchecked, the Width, Depth, and Height can be edited independent of one another, potentially changing the object's shape. Check this box to maintain the ratio between these settings when the object is resized in this dialog. This box does not affect editing performed outside this dialog and is an action rather than a state: the next time you open this dialog, it will be unchecked.
- Click the **Show Advanced Options** button to access settings that control the object's bounding box size and how it behaves when resized, below. Not available when multiple objects are selected.

## 2 3D Geometry Dimensions

These values describe the size of the selected symbol's geometry.

- When **Update When Object Dimensions Change** is checked, the object's geometry will update when its Object Dimensions settings are modified.
- Specify the total **Width**, **Depth**, and **Height** of the object's 3D geometry.

## 3 Bounding Box Spacing

These values describe how far the selected object's bounding box extends beyond its surfaces on each side. See *Bounding Boxes on page 983*.

- When **Update When Object Dimensions Change** is checked, the object's bounding box spacing will update when its Object Dimensions settings are modified.
- Specify the **Left**, **Right**, **Front**, **Back**, **Top**, and **Bottom** bounding box spacing. A positive value creates a space between the object's geometry and its bounding box; a negative value recesses the bounding box into the object's geometry; a value of 0 positions the bounding box against the object.

## 4 Stretch Planes

Define where a symbol stretches when resized. If no stretch planes are used, the symbol resizes uniformly. See *Stretch Planes and Zones on page 983*.

- **Width** planes are oriented vertically and run from the back of the symbol to its front, or along the symbol's X axis.
- **Depth** planes are oriented vertically and run from one side of the symbol to the other, or along the symbol's Y axis.
- **Height** planes are oriented horizontally, or along the symbol's Z axis.





## 5 Uniform Stretch Zones Between

Define an area between two planes that stretches uniformly when the object is resized, leaving the area outside the zone unaffected.

Note: Stretch Planes and Stretch Zones do not affect a symbol's 2D CAD block, which always resizes in a uniform manner. If you resize a symbol using custom Stretch Planes and Zones, consider generating a new CAD Block. See *2D Block Panel on page 993*.

## 6 Preview

A preview of the selected symbol displays on the left. See *Dialog Preview Panes on page 22*.

- Click the **Select Stretch Plane Item**  button, then click on a stretch plane in the preview to select it. A selected Stretch plane can be moved using its edit handle. Only available when Show Stretch Planes is also toggled on.
- Click the **Show Origin**  button to toggle the display of blue, red, and green lines showing the directions of the symbol's X, Y, and Z axes and its origin. See *Symbol Origin on page 981*.
- Click the **Show Stretch Planes**  button to toggle the display of any stretch planes that the symbol may have. Stretch planes only display when the SIZING panel is active.
- Click the **Show Bounding Box**  button to toggle the display of the symbol's bounding box. This setting off by default but is retained during the current program session.

## LIGHT DATA PANEL

The LIGHT DATA panel is only available for Electrical symbol objects. The settings on this panel allow you to control the attributes of the light source(s) associated with the selected object. See *Light Data Panel on page 675*.

## 3D PANEL

The options on the 3D panel primarily affect the symbol's appearance in 3D views. This panel is only available when a symbol is in the process of being imported. See *Importing 3D Symbols on page 998*.

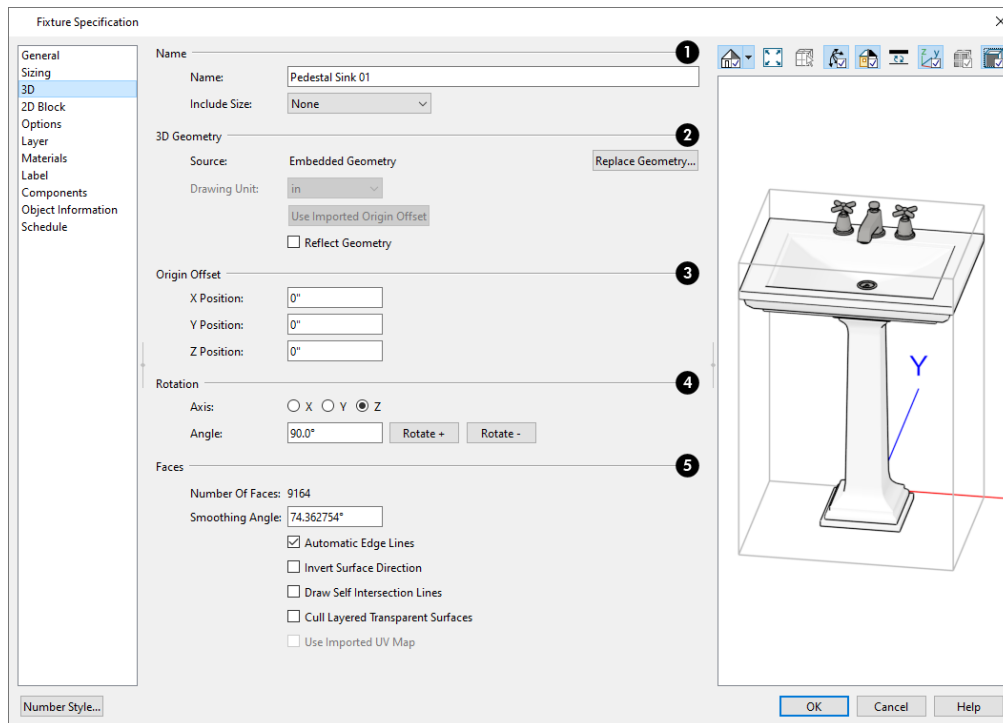

### 1 Name

Specify how the symbol's **Name** should appear in its object specification dialog, its label, in the Materials List, and in schedules. See *Materials Lists on page 1303*.

- Enter a **Symbol Name**. When imported into the program, a 3D symbol is given the same name as its file name. Not available when multiple symbols are selected. See [Importing 3D Symbols on page 998](#).
- Select a **Display Size** format from the drop-down list to append the name of the symbol with size information.

## 2 3D Geometry

- When a symbol is being imported, the pathname of the file being imported is reported here for reference. If multiple symbols are being imported, only one file displays. If the symbol is not in the process of being imported, “Embedded Geometry” displays instead.
- Click the **Replace Geometry** button to choose a file to associate with the selected symbol. Not available when a symbol is being imported or converted.
- Select the **Drawing Unit** that was used to create the symbol. If any units other than inches or mm are selected, the program will convert the data into units appropriate for Chief Architect. Only available when a symbol is being imported. To apply a change to this setting, you must also click the Browse button and reload the symbol data from the original file.

Note: SKP files are always imported using inches, regardless of the default units used in the plan file.

- Click the **Use Imported Origin Offset** button to use the symbol origin saved in the file being imported rather than use an origin based on the symbol’s type. Only available when a symbol is being imported. See [Symbol Origin on page 981](#).
- Check **Reflect Geometry** to reverse the object’s appearance, so that features on its left are positioned on its right, and vice versa. This turns a right-hand refrigerator, for example, into a left-hand refrigerator. This option has no effect on objects that are symmetrical.

## 3 Origin Offset

Specify the **Origin Offset**, which affects how the selected symbol is positioned when placed in a Chief Architect plan. Specifying a particular origin is helpful if the selected symbol will be inserted into another object, such as a sink to be placed in a cabinet. See [Symbol Origin on page 981](#).

- Leave these values at 0 to use Chief Architect’s default origin for the symbol. For most symbols, this is the appropriate option.
- Enter new values to manually adjust the origin. The values in the **X**, **Y**, and **Z** fields represent the offset of the symbol’s origin point from the default Chief Architect origin. This option is appropriate for symbols that will be placed within other objects.

## 4 Rotation

These settings allow you to rotate the selected symbol(s) about the X, Y, and Z axes. Note that rotating a symbol will affect the location of its top, bottom, front, and /or back - and thus the location of its default origin. It may affect the size of the bounding box, as well; however, it does not affect the bounding box’s orientation. See [Bounding Boxes on page 983](#).

- Select the **X**, **Y**, or **Z Axis** that you wish to rotate the symbol about.
- Specify the **Angle** to rotate the symbol in the text field. An angle of 90° is set by default.

- Click the **Rotate +** button to rotate the symbol around the selected axis in a clockwise direction.
- Click the **Rotate -** button to rotate the symbol around the selected axis in a counterclockwise direction.

## 5 Faces

Specify how the selected symbol's 3D Faces are generated.

- The **Number Of Faces** that a selected symbol has displays here for reference. When multiple symbols are being imported, nothing displays. Although there is no limit to the number of faces, large numbers can increase rendering time significantly.
- Specify the **Smoothing Angle**, which determines whether two adjacent surfaces are shown with a smooth or sharp angle between them in rendered views. If the angle between two surface normals is less than this angle, normal averaging is used to give the effect of a curved surface. This value also effects the generation of automatic edge lines.

A good example is a hexagonal cylinder. The angle between adjacent surfaces is  $360/8$ , or  $45^\circ$ . If you want it to look cylindrical, set the **Surface Smoothing Angle** to something greater than  $45^\circ$ . If you want to make the cylinder look hexagonal, set it to less than  $45^\circ$ .

- **Automatic Edge Lines** is checked by default so the program can choose an appropriate Smoothing Angle for legacy symbols migrated into version X15. It applies specifically to legacy symbols as they are brought into the program and in most cases, should remain checked.
- **Reverse Surface Direction** will be either checked or unchecked by the program automatically, depending on where the selected symbol was created: it is checked for symbols created in the program or imported from an **.skp** file, and typically unchecked for symbols imported from other file types.  
In most cases, this setting should not be changed; however, if you export a symbol and encounter problems with its surfaces, changing this setting may help.  
Note that Chief Architect imports the front side of faces in **.skp** files; however, it does not support faces with different textures on the front and back and will import the back side as a separate face.
- Check **Draw Self Intersection Lines** to display lines where parts of the selected symbol are drawn in such a manner that they occupy the same 3D space as other parts of the same symbol. In most cases, this box should be unchecked; and if the selected symbol does not have self intersection lines, it will not be available.
- Check **Cull Layered Transparent Surfaces** to if you need to troubleshoot the appearance of a transparent symbol. Generally, this box should be left unchecked.
- When a symbol is being imported, check **Use Imported UV Map** to preserve the UV map that was created for it. When unchecked, the symbol's textures are mapped using a modified version of its UV map that assumes square shaped texture images. If the symbol uses a "decal sheet" style texture or one that is not square in shape, this box should be checked.

## 6 Preview

A preview of the symbol's appearance displays here and updates as changes are made to the settings in this dialog. When multiple symbols are selected, the most recently selected symbol displays. See [Dialog Preview Panes on page 22](#).

- Click the **Show Origin**  button to display the location of the selected symbol's origin in the preview. Not available if Show Plan View is selected. See [Symbol Origin on page 981](#).



 If changes are made to an existing symbol in a plan or the Library Browser, you may also want to generate a new 2D Block to represent it in plan view.

## 2D BLOCK PANEL

The 2D BLOCK panel allows you to select a 2D CAD block to represent the selected symbol in plan view. See [CAD Blocks on page 329](#).

This panel is not available for Doors, Doorways, or Cabinet Doors, nor is it available when multiple symbols are being imported.

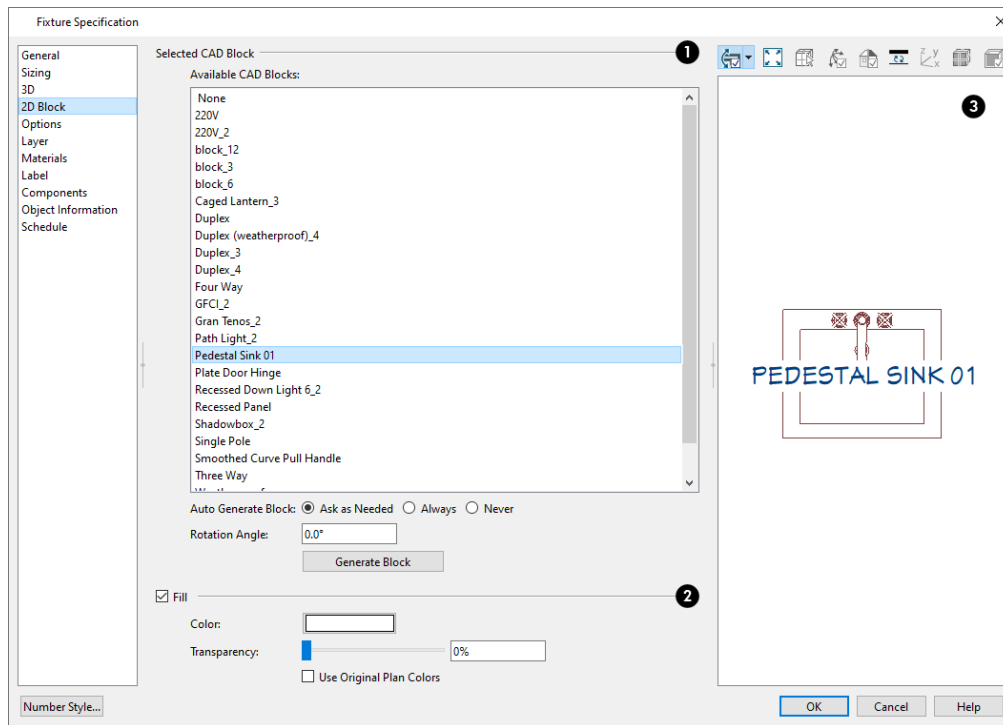

### 1 Selected CAD Block

- The CAD block associated with the selected symbol is selected in the list of **Available CAD Blocks** and displays in the preview.
- The CAD block name of an imported symbol will be based on the symbol’s original file name. See [Importing 3D Symbols on page 998](#).
- You can select a different CAD block from the list if you wish.
- Check **Auto Generate** to create a new CAD block to represent the selected symbol any time the symbol is rotated in a way that affects the appearance of its overhead projection.
- Click the **Generate Block** button to automatically generate a CAD block based on an overhead projection of the selected symbol and add it to the list.

 If you do not see a CAD block in this list that suits your needs, you can create your own. See [Custom 2D Symbols on page 332](#).

- Enter a **Rotation Angle** to rotate the 2D CAD block from its original angle of 0°. The orientation of the 2D CAD block in floor plan view does not affect the symbol’s orientation in 3D views.

## 2 Fill

In order to apply a specified fill, you may need to click the Generate Block button, above.

- Check **Fill** to specify a fill color in selected symbol’s CAD block and enable the settings that follow.
- Click the **Color** bar to select a fill color for the 2D block. See [Color Chooser/Select Color Dialog on page 203](#).
- Use the **Transparency** slider bar or text field to control how transparent the fill color is.
- Check **Use Original Plan Colors** to make the symbol’s fill color white.

## 3 Preview

A preview of the selected CAD Block displays here when Show Plan View is selected. See [Dialog Preview Panes on page 22](#).

## OPTIONS PANEL

The settings on the OPTIONS panel affect how a symbol behaves and can be placed. The available options on this panel vary, depending on the selected symbol’s category. Not available for Geometric Shapes or Sprinklers.

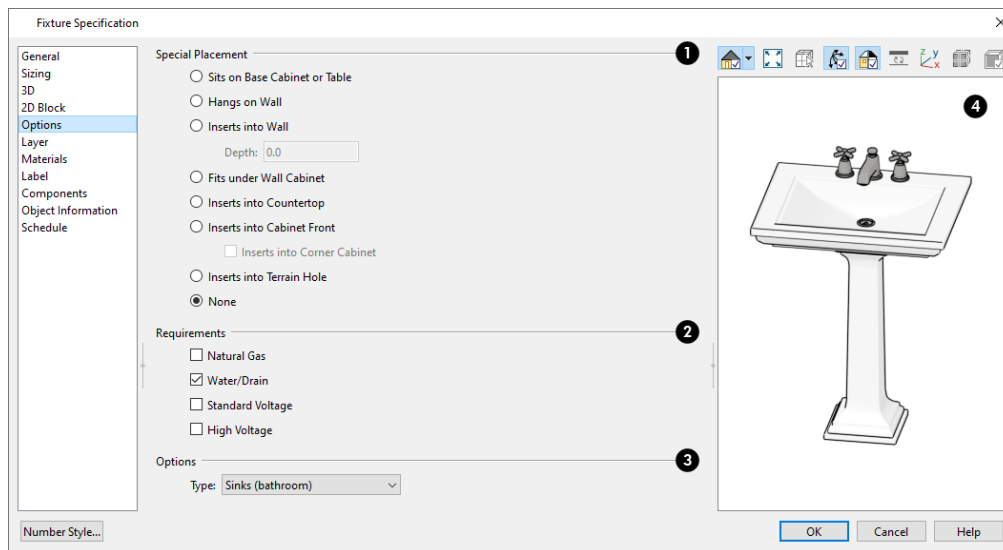

## 1 Special Placement

The **Special Placement** options add placement restrictions and abilities to the selected symbol. Once placed, its height or offset can be adjusted. See [Placing Library Objects on page 972](#).

- When an electrical object is specified as Ceiling Mounted, check **Flush Mounted** to specify that it follow the pitch of either the ceiling or roof.

## 2 Requirements

Specify whether the selected fixture symbol requires Natural Gas, Water/Drain, Standard Voltage, and/or High Voltage. This information can be reported in fixture schedules. See *Columns to Include on page 689*.

## 3 Options

Additional **Options** specify the selected symbol's purpose.

- Select a symbol **Type** from the drop-down list. The selection will vary depending on the symbol's Category.
- A variety of check boxes may be available, depending on the selected symbol's Category and Type.

## MATERIALS PANEL

The MATERIALS panel allows you to assign materials to the symbol's components and is similar to the Materials panel in many specification dialogs. See *Materials Panel on page 1055*.

If the selected symbol is in the process of being imported, bear in mind that **.dxf/.dwg** files do not include material information, so the symbol's components will not have materials assigned to them. See *3D Symbols and Materials on page 1000*.

## OPENING PANEL

The settings on the OPENING panel define the selected Window or Doorway symbol's rough opening when placed in a wall.

The OPENING panel is only available for Windows and Doorways.

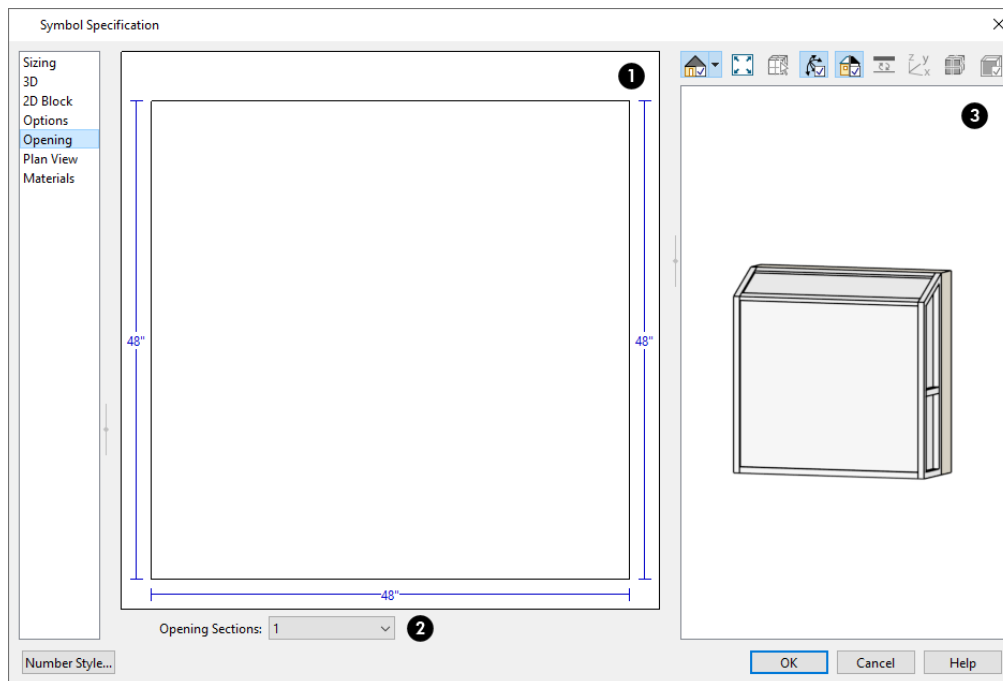

## 1 Opening Diagram

An editable diagram of the symbol's wall opening displays here.

Edit the symbol's opening size and shape by clicking on a dimension number and typing the desired value. To update the preview, press the Tab key.

## 2 Opening Sections

If the Window or Doorway has an angled or arched top, click the **Opening Sections** drop-down and choose the section diagram that most closely resembles the rough opening shape that you want. You can then edit the section as needed.

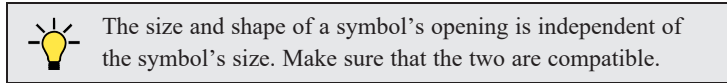

## PLAN VIEW PANEL

The PLAN VIEW panel controls the appearance of Window and Doorway symbols in floor plan view.

The PLAN VIEW panel is only available for Windows and Doorways.

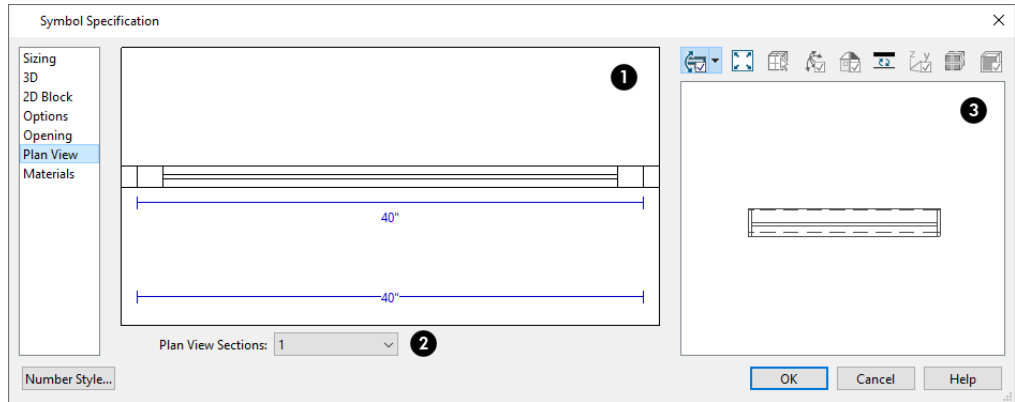

## 1 Plan View Diagram

An editable diagram of the symbol's representation in plan view displays here. The settings here also affect how many units the symbol contains as well as their size in both 2D and 3D views.

- To change the size of the symbol's units in floor plan view, click on a dimension number and type the desired value. Press the Tab key to update the diagram.
- To change a unit in the preview from a window to a door swing, click on the unit in the diagram.

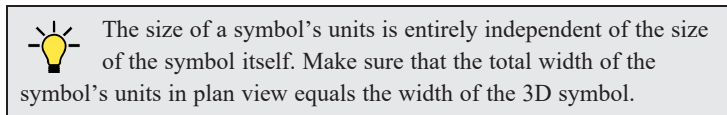

## 2 Plan View Sections

Click the **Plan View Sections** drop-down and choose the number of units contained by the Doorway or Window symbol. Up to five units are possible.

## PLANT INFORMATION PANEL

This panel is available when the Symbol Specification dialog is opened for a plant. The options are the same as the Plant Information panel of the Plant Symbol Specification dialog. See [Plant Information Panel on page 1299](#).

## **PLANT DESCRIPTION PANEL**

This panel is available when the Symbol Specification dialog is opened for a plant. The options are the same as the Plant Description panel of the Plant Symbol Specification dialog. See [Plant Description Panel on page 1300](#).

## **LAYER PANEL**

The LAYER panel is found in the specification dialogs for many different objects. For more information, see [Layer Panel on page 186](#).

## **FILL STYLE PANEL**

The FILL STYLE panel is available when the selected object is a sprinkler and controls how the area within its spray radius displays in plan view. It is similar to the FILL STYLE panel found in many dialogs. See [Fill Style Panel and Dialogs on page 193](#).

## **MATERIALS PANEL**

The MATERIALS panel allows you to assign materials to the symbol's components and is similar to the MATERIALS panel in many specification dialogs. See [Materials Panel on page 1055](#).

If the selected symbol is in the process of being imported, bear in mind that **.dxf/.dwg** files do not include material information, so the symbol's components will not initially have materials assigned to them. See [3D Symbols and Materials on page 1000](#).

In the Symbol Object Specification dialogs only, the names of the Components listed here can be customized: simply click on the Name of a selected component and type a short, descriptive name that better meets your needs. These names are not used elsewhere in the program.

## **LABEL PANEL**

A variety of library objects can display labels in plan view and cross section/elevation views. Labels use the Text Style assigned to the layer they are on.

For information about the settings on this tab, see [Label Panel on page 700](#).

## **COMPONENTS PANEL**

The information on the COMPONENTS panel can be used in the materials list. For more information, see [Components Panel on page 1330](#).

## **OBJECT INFORMATION PANEL**

The information entered on the OBJECT INFORMATION panel can be used in schedules and the materials list. For more information, see [Object Information Panel on page 1331](#).

## **SCHEDULE PANEL**

The settings on the SCHEDULE panel determine which schedule categories the selected object is included in. See [Schedule Panel on page 704](#).

## MANUFACTURER PANEL

The MANUFACTURER panel provides contact information for the selected object's manufacturer. Only available for symbols from Manufacturer library catalogs. See *Manufacturer Catalogs on page 961*.

---

## Importing 3D Symbols



Chief Architect supports the import of 3D surface and 3D solid objects saved in **.dwg**, **.dxf**, **.3ds**, **.obj**, **.stl**, **.dae**, and **.skp** formats. See *3D Data Import Requirements on page 999*.

For most file types, there are four ways to import a 3D symbol into Chief Architect:

- By selecting **File> Import> Import 3D Symbol**.
- By selecting **New> 3D Symbol** from the contextual menu in the Library Browser. See *Using the Contextual Menu on page 951*.
- By dragging and dropping the file from an operating system window into plan view.
- Some types of symbols can also be imported via the Select Library Object dialog. See *Select Library Object Dialog on page 974*.

3D **.dxf/.dwg** files can only be imported by selecting **File> Import> Import 3D Symbol**.

Symbols imported by clicking and dragging are imported for use in the current plan, while those imported using the Import 3D Symbol dialog can also be saved in the library. See *The Library on page 945*.

### *To drag and drop a 3D symbol file*

1. Open the plan in which you would like to import a 3D symbol and remain in plan view.
2. Open an operating system window in front of the Chief Architect program window.
3. Resize and position the window so that the Chief Architect program window can be seen behind it.
4. Click on the desired **.3ds**, **.obj**, **.stl**, **.dae**, or **.skp** file and drag it into the Chief Architect program window.
5. When your cursor changes to a +, click in the drawing area to place as many copies of the symbol as desired. When you are finished, select a different tool.

Symbols imported by clicking and dragging are imported as generic stand-alone interior fixtures. If you wish to assign the symbol to a different category, use the Import 3D Symbol dialog to import it.

## IMPORTING MULTIPLE SYMBOLS

More than one symbol can be imported into the Chief Architect library at a time provided that the following requirements are met:

- The symbols are located in the same folder on your computer.
- Multiple symbols can only be imported using the Import 3D Symbol dialog. If you try to drag and drop group-selected files in an operating system window, only the file that was selected first is imported.
- When imported as a group, symbols must be assigned to the same symbol category. If you wish to assign them to different categories, they must be imported separately.

Symbols that are imported as a group are assigned names based on their original file names with the file extension omitted.

## IMPORT 3D SYMBOL DIALOG

The Import 3D Symbol dialog, which opens next, allows you to specify additional information about the symbol.

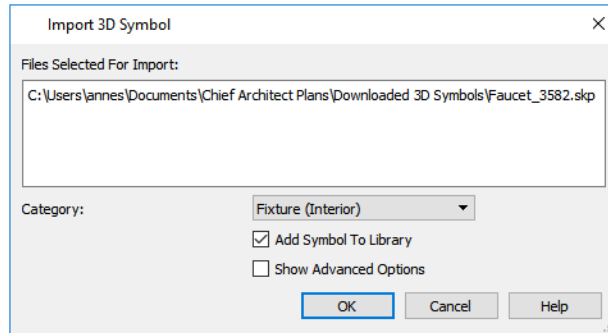

- The **Files Selected for Import** display here for reference.
- Choose a symbol **Category** from the drop-down list. The category affects how and where the symbol can be used, and cannot be changed after it is imported. See [Symbol Categories on page 1003](#).
- Check **Add Symbol to Library** to save the symbol in the User Catalog. This is always checked when multiple symbols files are selected. See [Add to Library on page 965](#).
- Check **Show Advanced Options** to open the symbol’s specification dialog. See [Symbol Object Specification Dialogs on page 986](#).
- Click **OK** to import the symbol, then click in plan view to place the symbol at that location. Continue clicking to place as many copies of the symbol as needed. Select another tool when finished.

If you import a **.obj**, **.3ds** or **.skp** file with textures that are already present in your library, the Texture Filename Conflict dialog opens. See [Texture Filename Conflict on page 1001](#).

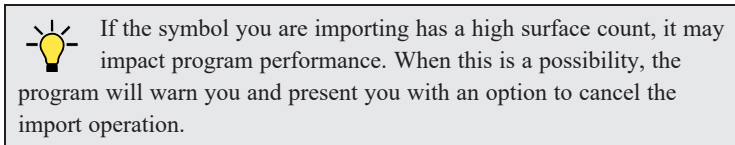

---

## 3D Data Import Requirements

Importing a symbol that can be used by Chief Architect is a relatively simple process that begins with previously created 3D data. This 3D data often comes from a program other than Chief Architect. If you use another 3D modeling program to create the 3D data, be aware of the following requirements before attempting to create symbols.

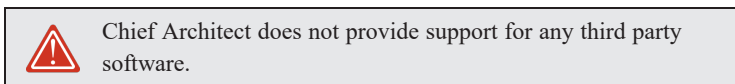

There are a number of requirements that must be met before any 3D data can be used to create a symbol in Chief Architect Premier:

- The 3D data must be stored in a standard Drawing Exchange File (**.dxf**), AutoCAD® Drawing (**.dwg**), object (**.obj**), 3D Studio® Mesh (**.3ds**), stereolithography (**.stl**), COLLADA (**.dae**), or SketchUp version 2021 and prior (**.skp**) file format. If you have 3D data in another format, you must convert it into one these formats first.
- Geometry and material information stored in **.3ds** files are imported; cameras and lights are not.

- The 3D model must be composed of 3D DWG or 3DSOLID solid entities, or face data. Faces are typically referred to as 3D faces, polygonal faces, or poly meshes. Other types of entities such as lines, curves, circles, polylines, and free form surfaces can exist in the file but are not imported when the symbol is created. This is true for all (.dxf/.dwg/.obj/.3ds/.skp) file types.
- The face data should be assigned to different layers so that you can map them to the correct materials when viewing them in 3D. It is helpful to name your layers using a convention that identifies that materials should be assigned to each sub-component.
- Pay attention to the origin and orientation of the 3D data when designing symbols. Chief Architect allows some adjustment when creating the symbol, but it is easier to build the 3D data correctly before importing it into Chief Architect. For more information about defining the origin, see [Symbol Origin on page 981](#).
- If a symbol with faces that have more than four vertices is imported, the faces are truncated, resulting in an object that appears to have holes. The best remedy is to re-export the model from the original application using only triangular or quadrilateral faces.
- Chief Architect does not support grouped objects in symbols imported from .3ds files.

## SURFACE NORMALS

If you use third party software to create a .dxf/.dwg/.obj/.3ds/.skp file that will be imported as a symbol, you should be familiar with the concept of surface normals.

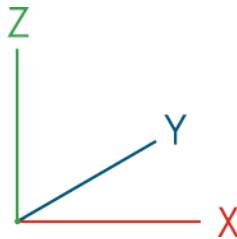

A surface normal is a vector that is perpendicular to the plane of a surface. This vector points in one direction, determined by the way the face is drawn.

If a face is drawn clockwise, the surface normals are directed outward; if a face is drawn counter-clockwise, the surface normals point inward. Chief Architect assumes that the face on the positive side of the normal vector is the outside face.

Many objects can be drawn using only one side of each face. A cube is a good example: the inside of a cube is not visible, so it is not necessary to create its inside faces. When inside faces are not calculated, 3D views in Chief Architect can generate more quickly.

---

## 3D Symbols and Materials

When a symbol is imported into Chief Architect, material definitions may be included with it. Whether and how material information is included depends on the symbol's file format. See [About Materials on page 1050](#).

### *DXF/DWG and STL Files*

.dxf/.dwg and .stl files do not include information about material definitions. When imported, default materials for the selected symbol type will be assigned. If the .dxf/.dwg or .stl file associated with a symbol is changed, all previously specified material information for the symbol will be lost.

All layers, layer names, solids and instances of blocked solids from the .dxf/.dwg or .stl file display in the list of components on the left side of the MATERIALS panel of its specification dialog. See [Materials Panel on page 1055](#).



### **OBJ Files**

Material definitions for most **.obj** files are saved in a separate file with the **.mtl** file extension. If such a file exists, the materials associated with the **.obj** file display in the list on the left side of the MATERIALS panel of its specification dialog.

If Chief Architect does not receive material definition information in an accompanying **.mtl** file, default material properties are assigned.

Material definitions for **.obj** files can also include texture information in the form of image files (**.jpg**, **.png**, etc).

In order to properly import an **.obj** file, Chief Architect needs the **.obj** file, the **.mtl** file, and any referenced texture files. If a texture file is not available, the material it is associated with is created without a texture.

The material definitions associated with an imported **.obj** symbol are not available for use by other objects in Chief Architect until that symbol has been placed into a plan. The associated texture files are then copied to the user's Textures folder. See *Chief Architect Premier Data on page 37*.

### **3DS and DAE Files**

Material definitions for **.3ds** and **.dae** files refer to texture information in separate image files.

In order to properly import a **.3ds** and **.dae** file, Chief Architect needs these referenced image files. If a texture file is not available, the material it is associated with will be created without it. The associated texture files are copied to the user's Textures folder.

### **SKP Files**

The textures associated with a **.skp** file are saved in the file. After you import a symbol and either place it in a plan or add it to the Library, these textures are saved in the user's Textures folder.

Chief Architect does not support deformed textures. If a texture associated with a **.skp** file is deformed, it will be imported without the deformations.

## **TEXTURE FILENAME CONFLICT**

If a texture of the same name already exists in the plan when an **.obj**, **.3ds**, or **.skp** file is imported, the Texture Filename Conflict dialog displays.

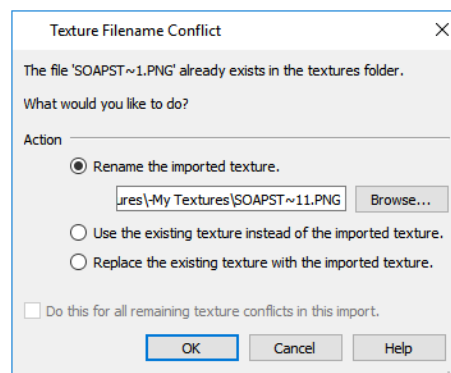

- Select **Rename the imported texture**, then click the **Browse** button to create a copy of the texture's image file with a new name that you specify.
- Select **Use the existing texture instead of the imported texture** to keep the existing texture.
- Select **Replace the existing texture with the imported texture** to replace the texture already present in the plan with the new, imported one.
- Check **Do this for all remaining textures in this object** to use the same selection for all textures with filename conflicts associated with this symbol.

## Get Last Symbol

 If you import or convert a symbol that cannot be placed in the current view or must be contained by another object that is not present in the view, you can quickly select it for placement once the needed conditions are met using the **Get Last Symbol** command.

Open a view in which the symbol can be placed or create an object to place the symbol into, then select **Tools> Symbol> Get Last Symbol**  to retrieve the last symbol created and click in your plan to place the symbol.

## Convert to Symbol

 Most objects in Chief Architect can be converted into symbols. To do this, select one or more architectural objects in floor plan, camera, or cross section/elevation view and click the **Convert to Symbol** edit button. See [Architectural vs CAD Objects on page 158](#).

Note: Image objects cannot be converted into symbols. See [Images on page 1185](#).

You can create custom symbols in Chief Architect using any combination of architectural objects.

Particularly if you are designing a custom object using generic objects like Primitives, it is helpful to begin by opening a new, blank plan. Then, place any combination of architectural objects to produce a model of what you would like your custom symbol to look like.

When the objects are configured as desired, select them and then use the **Convert Selected to Symbol**  edit tool to create a single symbol that is assigned to a category that reflects how the object will be used. For example, if you design a cabinet door, select Cabinet Door/Drawer as the symbol's category so that the resulting symbol can be assigned to a cabinet.

When you want to convert a large number of objects into a single symbol, it may be easier to do so in a 3D view.

### To convert a 3D model to a symbol

1. Create a camera view or overview in which the only objects displaying are those that you wish to convert to a single symbol.
2. Select **Tools> Symbol> Convert to Symbol** .
3. In the Convert to Symbol dialog:

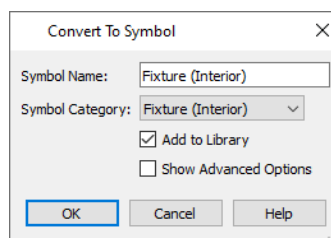

- Type a short, descriptive **Symbol Name**. The Symbol Category will populate this field unless a custom name is specified.

- Choose a **Symbol Category** from the drop-down list. When you select a category, the Symbol Name will automatically update to use that category. See *Symbol Categories on page 1003*.
  - Check **Add to Library** if you would like the symbol to be added to the library. See *Add to Library on page 965*.
  - Check **Show Advanced Options** to open the Symbol Specification dialog when you click OK, where you have more extensive control over the symbol's settings. See *Symbol Object Specification Dialogs on page 986*.
4. Click **OK** to close the dialog and convert your custom object to a symbol. Depending on the size of the symbol, a Progress dialog may display during this process.

Note: Some proprietary 3D data provided in Manufacturer catalogs cannot be converted to a symbol. The program will notify you if this protected data is included in the symbol you are trying to create. See *Manufacturer Catalogs on page 961*.

## Symbol Categories

The category that you assign to a symbol will influence how the symbol can be placed in a plan and how it will appear in the Materials List and in schedules. See *Materials Lists on page 1303* and *Schedules and Object Labels on page 681*.

Category	Placement	Schedules and Materials Lists
<b>Cabinet Door/Drawer</b>	Can be assigned to a cabinet or free-standing. See <i>Cabinets on page 617</i> .	When free-standing, listed in Cabinets category of Materials Lists. When assigned to a cabinet, listed as a component of the cabinet in Materials Lists and Cabinet Schedules.
<b>Door</b>	Can only be placed in a wall or assigned to a doorway. See <i>Doors on page 543</i> .	Listed in Doors category of Materials Lists; can be included in Door Schedules.
<b>Doorway</b>	Can only be placed in a wall. See <i>Doorways on page 546</i> .	Listed in Doors category of Materials Lists; can be included in Door Schedules.
<b>Electrical</b>	Can be specified as a variety of free-standing electrical items and may be ceiling-, floor-, wall- or cabinet-mounted. See <i>Electrical on page 666</i> .	Listed in Electrical category of Materials Lists; can be included in Electrical Schedules.
<b>Fixture (Exterior)</b>	Exterior Fixtures can act as plumbing items or appliances and have many different options. They may be free-standing, inserted into a cabinet, mounted on the ceiling, a wall, under a cabinet or on a roof.	Listed in Fixtures category of Materials Lists; can be included in Fixture Schedules.
<b>Fixture (Interior)</b>	Interior Fixtures can act as plumbing items or appliances and, like Exterior Fixtures, have many different options.	Listed in Fixtures category of Materials Lists; can be included in Fixture Schedules.
<b>Furnishings (Exterior)</b>	Can only be placed as a free-standing object but can be ceiling-, floor- or roof-mounted.	Listed in Furniture category of Materials Lists; can be included in Furniture Schedules.
<b>Furnishings (Interior)</b>	Can only be placed as a free-standing object but can be ceiling-, floor- or roof-mounted.	Listed in Furniture category of Materials Lists; can be included in Furniture Schedules.
<b>Geometric Shapes</b>	Can only be placed as free-standing object. See <i>General Shapes on page 1033</i> .	Listed in General category of Materials Lists.

Category	Placement	Schedules and Materials Lists
<b>Hardware</b>	Can be specified as a hinge, handle or lock and assigned to a cabinet, to a door, or free-standing.	Listed as a component of the object it is assigned to in Materials Lists or in Hardware category when free-standing; can be included in schedules as a component of the object it is assigned to.
<b>Millwork</b>	Can be free-standing or assigned to an object such as a railing or cabinet. See <i>Moldings and Millwork on page 926</i> .	Listed in Exterior Trim, Interior Trim, or Fixtures category of Materials Lists. May be included in Fixtures Schedules.
<b>Molding</b>	Can only be assigned to a room, cabinet, countertop or molding polyline. See <i>Trim and Moldings on page 920</i> .	Listed in Exterior Trim or Interior Trim category of Materials Lists.
<b>Plant</b>	Can only be placed as a free-standing object. See <i>Plant Tools on page 1294</i> .	Listed in Landscaping category of Materials Lists; can be included in Plant Schedules.
<b>Sprinkler</b>	Can only be placed as a free-standing object. See <i>Sprinkler Tools on page 1301</i> .	Listed in Landscaping category of Materials Lists.
<b>Window</b>	Can only be placed in a wall. See <i>Windows on page 576</i> .	Listed in Windows category of Materials Lists; can be included in Window Schedules.

## Exporting a 3D Model

The entire 3D model, or any part that you choose, can be exported from Chief Architect into one of four formats:

- *3DS Format on page 1005*
- *DAE Format on page 1005*
- *STL Format on page 1005*
- *DXF/DWG Format on page 1005*

### To export a 3D model

1. A camera view or overview must be active. See *Types of 3D Views on page 1080*.
2. Make sure that everything that you want to export is set to display in the current view, and everything you do not want to export is not set to display. See *Layers on page 176*.
  - Any surfaces removed using the **Delete Surfaces**  tool will not be exported. See *Displaying 3D Views on page 1097*.
3. When the model is ready, select **File> Export>** and choose the file format that you want to use.
4. Give the file a name, making sure to save it in the desired location. See *Exporting Files on page 41*.

Note: Some proprietary 3D data provided in Manufacturer catalogs cannot be exported. The program will notify you if this protected data is included in the model you are trying to export. See *Manufacturer Catalogs on page 961*.

### 3DS FORMAT

 A **.3ds** file can be opened by any program that uses 3D Studio®'s **.3ds** format. When the model is ready, select **File> Export> 3D Model (3DS)** to export to this format.

The Export 3D Studio (3DS) Mesh dialog opens:

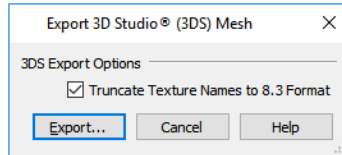

- Check **Truncate Texture Names to 8.3 format** to truncate material and object names to an eight character file name with a three character extension. This allows import into applications that support only legacy **.3ds** files.

The Export 3D Studio® (3DS) Mesh dialog, which opens next, is a typical File Save dialog.

Any material textures used in the model are saved as image files in the same location as the saved **.3ds** file. You may find it helpful to export the **.3ds** file to an empty folder created for this purpose.

### DAE FORMAT

 A **.dae** file can be opened by any program that uses COLLADA™'s **.dae** format. When the model is ready, select **File> Export> 3D COLLADA Model** to export to this format.

The Export COLLADA Model dialog is a typical File Save dialog.

With the exception of Rope Lights, any light sources that are On in the current view, as well as ambient light, will be exported to a **.dae** file along with the model. See [Lighting on page 1135](#).

Any material textures used in the model are saved as image files in a folder in the same location as the saved **.dae** file. The folder has the same name as the **.dae** file, appended with “\_textures”.

### STL FORMAT

 An **.stl** file can be opened by any program that uses Stereolithography format, and can be printed using a stereolithography machine, or 3D printer. When the model is ready, select **File> Export> 3D Model (STL)**.

The Export STL Model dialog is a typical File Save dialog.

A 3D model exported to an **.stl** file does not include any material or texture information.

### DXF/DWG FORMAT

 A **.dxf** or **.dwg** file can be opened by any program that uses AutoCAD®'s 3D **.dxf** or **.dwg** format. When the model is ready, select **File> Export> 3D Model (DWG/DXF)** to export to this format.

The entire 3D model, including geometry, is exported.



### 3D DXF/DWG LAYER NAMES

When you export a 3D model to **.dxf/.dwg** format, all surfaces are exported as 3DFACE entities. These entities are placed on layers that are named by Chief Architect.

A complete list of the layer names and associated objects is found in the program's Help by browsing to **Importing and Exporting > Exporting a 3D Model**. See *Contextual Help on page 31*.

# Architectural Blocks

## Chapter 29

An architectural block is a collection of individual 3D objects that are grouped together so that they can be placed and moved as a single object. Although blocked together, these objects retain many of their own attributes, such as materials.

Architectural blocks can also be exploded so that the individual sub-objects become independent of one another.

### TOPICS

<b>Architectural vs CAD Blocks</b> .....	<b>1008</b>
<b>Creating Architectural Blocks</b> .....	<b>1008</b>
<b>Displaying Architectural Blocks</b> .....	<b>1008</b>
<b>Editing Architectural Blocks</b> .....	<b>1009</b>
<b>Architectural Block Specification Dialog</b> .....	<b>1010</b>
<b>Architectural Blocks, Sub-Objects, and Components</b> .....	<b>1012</b>

---

## Architectural vs CAD Blocks

Just as there are two types of objects in Chief Architect, architectural and CAD, there are two types of blocks. See [Architectural vs CAD Objects on page 158](#).

Architectural objects such as cabinets and fixtures can be included in architectural blocks, while CAD objects such as lines, arcs, text and dimensions can be included in CAD blocks. See [CAD Blocks on page 329](#).

Knowing the differences between these two types of blocks helps you decide which type of block can best meet your needs.

A CAD block can include and also be nested in a larger block with CAD objects, text and dimensions, but cannot include or be blocked with architectural objects.

An architectural block can include and also be nested in a larger block with architectural objects, but cannot include or be blocked with CAD objects, text or dimensions.

---

## Creating Architectural Blocks



To create an architectural block, group-select multiple architectural objects, then click the **Make Architectural Block** edit button. Architectural blocks can be created in any view. See [Architectural vs CAD Objects on page 158](#).

The following is a list of objects that can be included in architectural blocks:

- Cabinets (Base, Wall, Full Height)
- Custom Countertops and Counter Holes
- Soffits, Shelves, Partitions
- Fixture and Furniture symbols
- Hardware symbols
- Millwork symbols
- Geometric Shapes
- Electrical objects
- Images
- Slabs and Foundation Slabs
- Primitives and 3D Solids
- Molding Polylines
- Roads, Driveways, Sidewalks
- Terrain Features and Terrain Modifiers
- Distribution Paths and Regions that have architectural objects as their distributed object.

Once blocked, the set of blocked objects is contained in a bounding box, indicating that they are now an architectural block.

---

## Displaying Architectural Blocks



As with individual objects, the display of architectural blocks is controlled in the Layer Display Options dialog. See [Layer Attributes on page 177](#).



- If an architectural block is composed of objects that are on the same layer, the block will be placed on that layer, as well.
- If an architectural block is composed of objects on different layers, the block will be placed on the “Architectural Blocks” layer.
- Once created, an architectural block can be placed on any layer you wish.

## IN PLAN VIEW

The sub-objects of a block can use the layer attributes assigned to their current layer or the layer attributes assigned to the block. See *General Panel on page 1011*.

You can control the appearance of the bounding box by changing the display properties of the architectural block’s layer or you can turn off its display in the Architectural Block Specification dialog. See *General Panel on page 1011*.

Like other objects, an architectural block is placed in a Drawing Group that affects whether it displays in front of or behind other objects. You can modify a selected architectural block’s place in the drawing order by clicking the **View Drawing Group Edit Tools**  edit button. See *Drawing Group Edit Tools on page 190*.

## ARCHITECTURAL BLOCK LABELS

Architectural blocks can display labels for both the block and any component objects that have labels in plan and cross section/elevation views. As with the objects they are associated with, you can turn off the display of component labels by layer. Labels for architectural blocks are placed on the “Architectural Blocks, Labels” layer and use the Text Style assigned to that layer. See *Label Panel on page 700*.

The label for an architectural block can be generated automatically, user-specified, or suppressed. See *Architectural Block Specification Dialog on page 1010*.

## IN MATERIALS LISTS AND SCHEDULES

An architectural block can appear as a single unit or its sub-objects and components can be listed separately in materials lists and schedules. As with other objects, you can choose whether to include architectural blocks in materials lists and schedules. See *Materials Lists on page 1303* and *Schedules and Object Labels on page 681*.

---

# Editing Architectural Blocks

Architectural blocks can be selected and edited in 2D and 3D views. See *Selecting Objects on page 210*.

Note: Moving an architectural block in 3D view regenerates the view. If the architectural block contains terrain objects, the terrain is rebuilt.

Once selected, an architectural block can be edited using its edit handles, edit toolbar buttons, and specification dialog. See *Architectural Block Specification Dialog on page 1010*.

## USING THE EDIT HANDLES

A selected architectural block displays a Move handle and a Rotate handle. If the block has a label, it also has its own Move and Rotate handles.

Architectural blocks cannot be resized, but the individual objects in a block can be.

## IN THE SPECIFICATION DIALOG



Architectural blocks can be edited in their specification dialog. See *Architectural Block Specification Dialog on page 1010*.

## USING THE EDIT TOOLS

A selected architectural block or blocks can be edited in a variety of ways using the buttons on the Edit Toolbar. See *The Edit Toolbar on page 130*.

## EDITING SUB-OBJECTS

The individual objects included in an architectural block can also be selected and edited. See *To select a sub-object on page 1013*.

## EXPLODE ARCHITECTURAL BLOCK



You can break an architectural block to make its objects independent. Select the architectural block and click the **Explode Architectural Block** edit button.

Note: If you open a plan created in the Premier version of Chief Architect and an architectural block includes an object that you cannot create in your version of the software, you cannot unblock it or edit its components.

## ADDING ARCHITECTURAL BLOCKS TO THE LIBRARY



You can create your own architectural blocks and save them in the library. See *Add to Library on page 965*.



Architectural blocks, their component objects, as well as inserted symbols or assigned attributes like materials or moldings associated with those component objects can be added to the library using the **Add to Library As** edit tool. See *Add to Library As on page 966*.

---

# Architectural Block Specification Dialog



The Architectural Block Specification dialog controls the way architectural blocks display in plan view, in schedules, and in materials lists. Select one or more architectural blocks and click the **Open Object** edit button to open this dialog.

## GENERAL PANEL

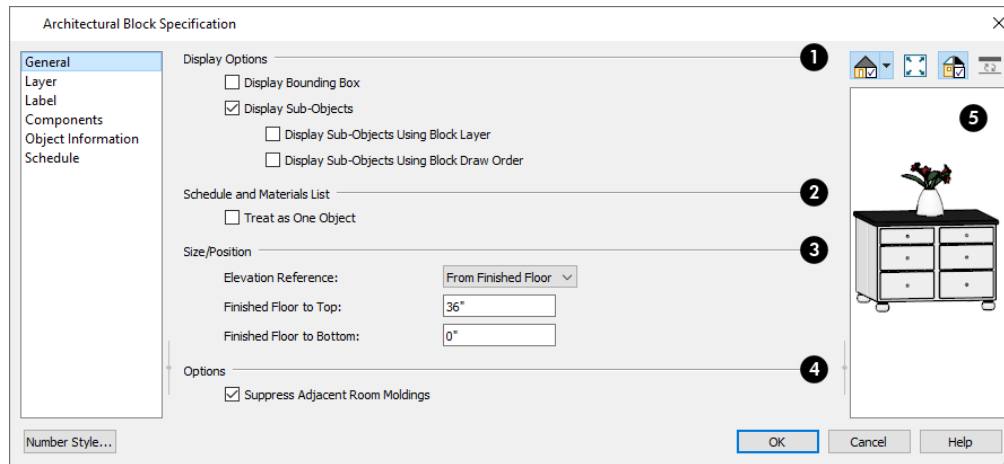

### 1 Display Options

These settings control the appearance of the selected architectural block in plan view. See *Displaying Architectural Blocks on page 1008*.

- Check **Display Bounding Box** to show the bounding box of the objects in the architectural block.
- Uncheck **Display Sub-Objects** to suppress the display of the sub-objects and display only the bounding box. If Display Bounding Box is unchecked, it will become checked.
- Check **Display Sub-Objects Using Block Layer** to apply the display properties of the architectural block's layer to its sub-objects. When this box is unchecked, sub-objects use the display properties set for their layers.
- Check **Display Sub-Objects Using Block Draw Order** to display all component objects of the selected block using the block's drawing order. When unchecked, each component displays according to its individual drawing order. See *Drawing Groups on page 190*.

### 2 Schedule and Materials List

These settings control how the selected architectural block appears in schedules and the materials list.

- Check **Treat as One Object** to treat the architectural block as a single unit in materials lists and schedules. This box must be checked in order for the settings on the SCHEDULE PANEL to be available for use.

### 3 Size/Position

These settings are not available if the selected block includes any objects such as electrical objects that do not have these settings in their individual specification dialogs.

- Select the **Elevation Reference** from the drop-down list. This determines where the next two settings are measured from and also affects their setting labels.
- Specify the height **to Top**, measured from the selected Elevation Reference to the top of the architectural block.
- Specify the height **to Bottom**, measured from the selected Elevation Reference to the bottom of the architectural block.

#### 4 Options

- When **Suppress Adjacent Room Moldings** is checked, a room's base, chair, and/or crown moldings will not generate where the selected block's bounding box crosses them when positioned against a wall. When unchecked, room moldings are not affected by the block and generate normally. See *Room Moldings on page 436*.

#### 5 Preview

A preview of the selected cabinet displays on the right side of the panel. See *Dialog Preview Panes on page 22*.

### LAYER PANEL

For information about the LAYER panel, see *Layer Panel on page 186*.

### LABEL PANEL

Labels for Architectural Blocks display in plan view when the “Architectural Blocks, Labels” layer is turned on and use the Text Style assigned to that layer. See *Architectural Block Labels on page 1009*.

The LABEL panel is available for a variety of different objects. For more information, see *Label Panel on page 700*.

### COMPONENTS PANEL

The information on the COMPONENTS panel can be used in the materials list. For more information, see *Components Panel on page 1330*.

### OBJECT INFORMATION PANEL

The information entered on the OBJECT INFORMATION panel can be used in schedules and the materials list. For more information, see *Object Information Panel on page 1331*.

### SCHEDULE PANEL

The settings on the SCHEDULE panel determine which schedule categories the selected architectural block is included in. These settings are only available when **Treat as One Object** is checked on the GENERAL panel. See *Schedule Panel on page 704*.

---

## Architectural Blocks, Sub-Objects, and Components



An architectural block is composed of a group of sub-objects that have been blocked together. For example, a kitchen island architectural block may consist of cabinets, appliances, a custom countertop, and other accessories.

Each of the sub-objects in an architectural block may contain additional parts called components. The cabinets in a kitchen island, for example, may contain handles, hinges, and drawer glide.



Architectural blocks can be treated as a single unit in materials lists and schedules, ignoring sub-objects and their components. See *General Panel on page 1011*.

## SUB-OBJECTS

Certain attributes of an architectural block can be edited at the sub-object level. A sub-object can be edited by accessing its specification dialog in either of two ways:

- Explode the architectural block, select the sub-object, and click the **Open Object**  edit button.
- Select the sub-object while it is part of the architectural block and click the **Open Object**  edit button. Some attributes may not be editable while the object is part of a block. See *Editing Architectural Blocks on page 1009*.

### *To select a sub-object*

1. Click the **Select Objects**  button, then click on the sub-object that you would like to edit.
2. With the architectural block selected, click the **Select Next Object**  edit button or press the Tab key.  
The selection switches to the individual object and it can be edited using its edit handles, edit toolbar and specification dialog.

The options for editing a sub-object may be more restricted than if the object were independent. If more extensive editing is required, the architectural block must be exploded. See *Explode Architectural Block on page 1010*.

## COMPONENTS

You can view and modify the components of an architectural block or group of blocks in the Architectural Block Specification dialog. The COMPONENTS panel lists all the sub-objects that comprise an architectural block, as well as the components that make up each sub-object. See *Components Panel on page 1330*.

# Other Objects

# Chapter 30

Chief Architect has additional objects that can be used to customize your design.

## TOPICS

<b>Primitive Tools</b> .....	<b>1015</b>
<b>Creating Primitives</b> .....	<b>1015</b>
<b>Editing Primitives and 3D Solids</b> .....	<b>1017</b>
<b>Creating Complex Structures with Primitives</b> .....	<b>1021</b>
<b>3D Solid Specification Dialog</b> .....	<b>1022</b>
<b>Sphere Specification Dialog</b> .....	<b>1025</b>
<b>Cylinder Specification Dialog</b> .....	<b>1026</b>
<b>Cone Specification Dialog</b> .....	<b>1028</b>
<b>Pyramid Specification Dialog</b> .....	<b>1030</b>
<b>General Shapes</b> .....	<b>1033</b>
<b>Soffits</b> .....	<b>1033</b>
<b>Soffit Specification Dialog</b> .....	<b>1034</b>
<b>Floor and Wall Material Regions</b> .....	<b>1037</b>
<b>Material Region Specification Dialog</b> .....	<b>1038</b>
<b>Material Layers Definition Dialogs</b> .....	<b>1040</b>
<b>Distributed Objects</b> .....	<b>1042</b>
<b>Distribution Region/Path Specification Dialogs</b> .....	<b>1043</b>

---

## Primitive Tools



The Primitive Tools allow you to create basic solid geometric shapes, which can be combined to create a wide variety of custom solid objects. Select **Build> Primitive** to access the Primitive Tools.

With the exception of Faces, objects made with the Primitive Tools are included in materials list calculations. For best results, a Volume type material should be used. See *Define Material Dialog on page 1066*.

### 3D SOLID



The **3D Solid** tool can be used to create rectangular solid objects in plan, cross section/elevation, and camera views. See *Creating Primitives on page 1015*.

### SPHERE



The **Sphere** tool can be used to create solid 3D spheres in plan and camera views.

### CYLINDER



The **Cylinder** tool can be used to create solid 3D cylinders in plan and camera views.

### CONE



The **Cone** tool can be used to create solid 3D cones in plan and camera views.

### PYRAMID



The **Pyramid** tool can be used to create solid 3D pyramids in plan and camera views.

### FACE



The **Face** tool can be used to create two-dimensional surfaces in plan, cross section/elevation, and camera views. Face objects are two-sided and be revolved or extruded to create custom Solid objects. See *Face Objects on page 1016*.







---

## Creating Primitives

Primitive solids are drawn similar to the way CAD boxes are. Depending on the view in which they are created, however, the method may differ somewhat.

### IN PLAN VIEW





In plan view, Primitives are drawn much the way closed CAD polylines are. Select a tool, then click and drag to define an area.

- To create **3D Solid** , click and drag to define the width and depth of the box's base. Its initial Height is 1" (25 mm).
- To create a **Sphere** , **Cylinder** , **Cone** , or **Pyramid** , click and drag to define the radius.
- As it is drawn, the height of a Cylinder, Cone, or Pyramid is equal to its radius.
- To create a spline-shaped 3D Solid, draw a **3D Solid** and click the **Convert to Spline**  edit button. This tool is not available if the selected object has been extruded along more than one axis. See [Convert to Spline on page 258](#).



Initially, the bottom surface of Boxes, Cylinders and Cones, and the center point of Spheres, are all set at 0" on the Z axis. See [Entering Coordinates on page 166](#).

## IN 3D VIEWS

In 3D views, the height of boxes, pyramids, cylinders and cones can be defined as they are drawn.

- To create a **3D Solid** , **Cylinder**  or **Cone** , click and drag to define the width and depth of the box's base. Release the mouse button, then drag upward or downward to define its height.
- Drag upward to set the height of the bottom surface at 0", or drag downward to set the top surface at 0".
- A **3D Solid** can also be drawn with its base against a wall instead of facing downward. When drawn in this manner, the default Height value of 1" (25 mm) is applied to the object's Depth instead.
- To create a **Sphere**  or **Pyramid** , click and drag in any direction to define its radius.

## IN CROSS SECTION/ELEVATION VIEWS

With the exception of **3D Solids**  and **Faces** , primitives cannot be created in cross section/elevation views. See [Cross Section/Elevation Views on page 1089](#).

## CONVERT TO 3D SOLID





Click the **Convert To 3D Solid** edit button to convert a selected Primitive, Custom Countertop, or Slab into a 3D Solid so that it can be used with other Solids to create complex structures.

## FACE OBJECTS

Regardless of the view, Faces are drawn the way line-based objects are when the **Alternate**  edit behavior is active. See [Alternate on page 207](#).

### To draw a Face

1. Select **Build> Primitive> Face** , then click, drag and release the mouse button to draw the first edge.
2. Click to define the endpoints of additional edges. A Face must have at least three edges.
3. To finish drawing, click at the original starting point. This is easiest to do when **Endpoint**  snapping is enabled. See [Object Snaps on page 160](#).

Once drawn, Faces can be revolved or extruded to create Solid objects. See [Extrude Object on page 1018](#).



---

## Editing Primitives and 3D Solids

Primitives can be selected individually and as a group and edited using the edit handles, the Edit Toolbar, dimensions, and their respective specification dialogs. See [Creating Complex Structures with Primitives on page 1021](#).

### USING THE EDIT HANDLES

The edit handles that are available on a selected Primitive depend on its object type. In plan view:

- 3D Solids are selected on their top edges and edited like closed polylines. If one of these objects has been rotated in 3D, more than one top surface may be visible in plan view; however, only one of these surfaces will be editable. Regardless of the orientation of the object or its surface angles, when it is rotated in plan view, it will rotate relative to the horizontal XY plane. If you want to rotate the object relative to one of its top faces, you can do so in a 3D view. See [Editing Closed Polyline-Based Objects on page 228](#).
- Faces are edited like much like other closed polylines.
- Pyramids have a more limited set of edit handles and can be moved, resized, and rotated.
- Spheres, cylinders, and cones are more limited still and can be moved and resized only.
- In plan and cross section/elevation views, 3D Solid labels also have a small square Move edit handle and small rectangular Rotate handle.

In 3D views:

- Faces, as well as each surface of a 3D Solid can be selected and edited like a closed polyline.
- Pyramids, cylinders, and cones can be moved, resized, and rotated. The axis of rotation will vary depending on where you click to select the object.
- Spheres can be moved and resized only.

In 3D views, most Primitives have a different set of edit handles for each selected edge, allowing you to rotate them in along more than one axis. These edit handles correspond to the object's **Rotation** settings in its specification dialog. To rotate a Primitive, it is often easiest to use its edit handles in a 3D view to orient it approximately the way you want it, then use the Rotation settings in its specification dialog to fine-tune its angles.

### USING THE EDIT TOOLS

A selected Primitive can be edited in a variety of ways using the buttons on the Edit Toolbar. See [The Edit Toolbar on page 130](#).

The **Union**, **Intersection**, and **Subtraction** edit tools are particularly useful edit tools for creating custom shapes. See [Union, Intersection, and Subtraction on page 274](#).

3D Solids and Faces have a number of edit tools that other Primitive tools do not, including **Convert to Plain Polyline**, **Convert to Spline**, **Fillet Lines**, and **Chamfer Lines**. See [Converting Objects on page 262](#), [Reshaping Objects on page 254](#), and [Polyline Holes on page 232](#).

### 3D SOLID FEATURE



The **3D Solid Feature** edit tool allows you to either create a hole in a selected 3D Solid or Face or, in 3D views, add an extrusion that extends out of a selected 3D Solid.

In plan view, this tool is used the same way the **Make Hole** edit tool is: simply draw a shape located entirely within a 3D Solid or Face. See *Polyline Holes on page 232*.

**To create an extrusion in a 3D view**

1. In a camera view, select a 3D Solid.
2. Click the **3D Solid Feature**  edit button.
3. Click and drag to draw a rectangular polyline at least partially located within the area of one surface of the object.
4. Release the mouse button and then drag the mouse pointer:
  - Towards the object surface to create a hole.
  - Away from the object surface to create an extrusion.

**EXTRUDE OBJECT**

 The **Extrude Object** edit tool allows you to produce a Solid object by extruding a selected Face or 3D Solid in any direction. See *3D Drafting on page 13*.

**To use Extrude Object**

1. Select a Face or 3D Solid and click the **Extrude Object**  edit button.

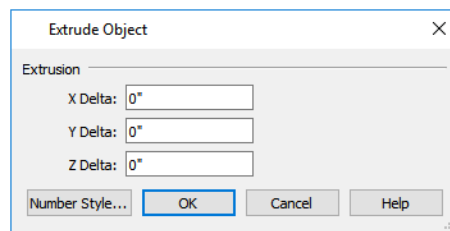

2. In the Extrude Object dialog, specify the **Extrusion Delta**, which is the direction and distance that the object is extruded.
  - Specify the distances that the object should extrude in the directions of each of the three axes.
3. Click OK.

**REVOLVE OBJECT**

 The **Revolve Object** edit tool allows you to produce a Solid object by extruding a selected Face or 3D Solid around an axis or point that you specify.

**To use Revolve Object**

1. Select a 3D Solid or Face.
2. Click the **Revolve Object**  edit button.
3. In the Revolve Object dialog, specify the **Axis of Rotation**, which determines the direction that the object will rotate. The Axis of Rotation is a line that is perpendicular to the direction in which the object will rotate. See *Coordinate System Indicators on page 145*.

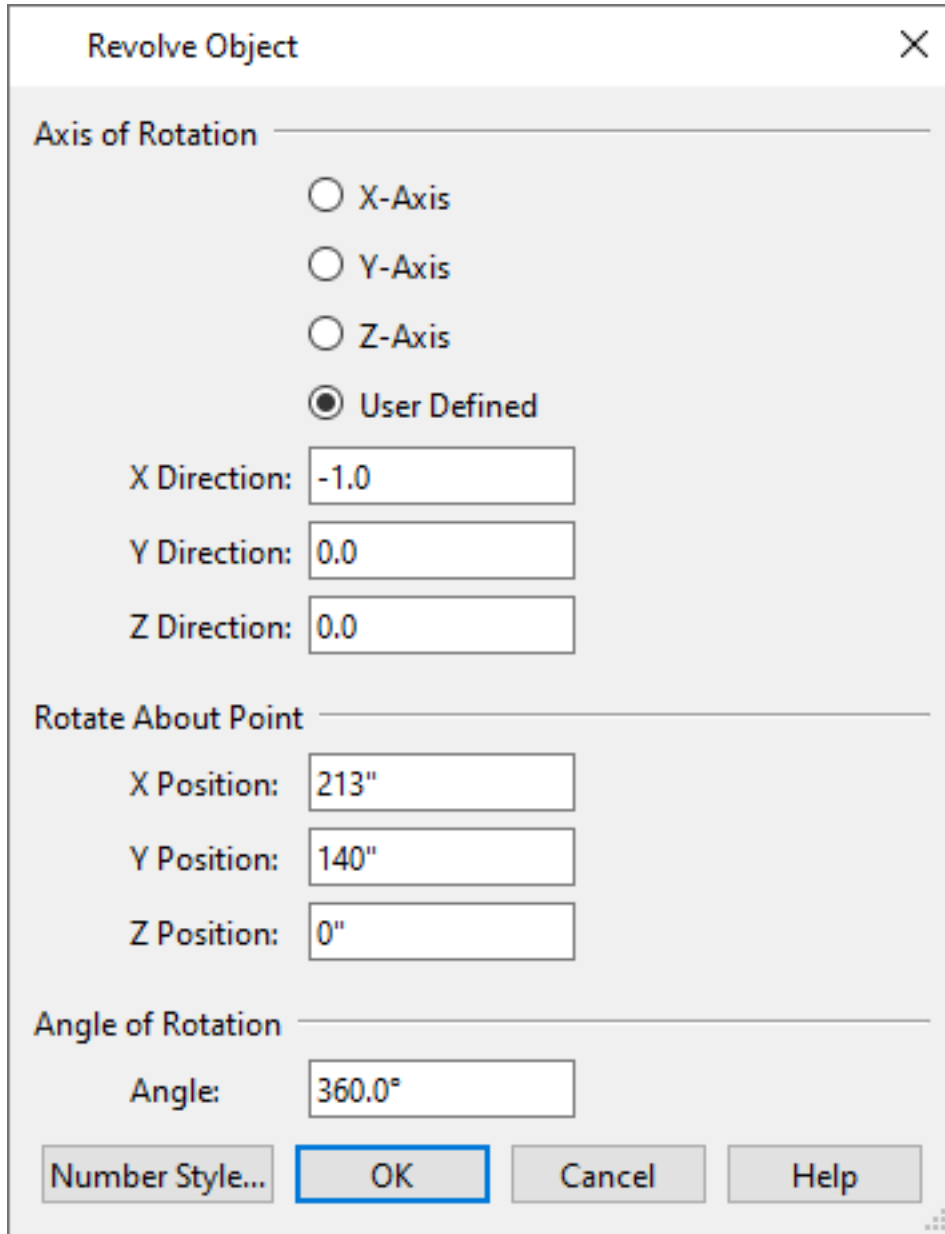





- Select **X-Axis** to revolve the object around a line that runs parallel to the X Axis in the current plan. The object will revolve in the Y and Z axes.
- Select **Y-Axis** to revolve the object around a line that runs parallel to the Y Axis in the current plan. The object will revolve in the X and Z axes.
- Select **Z-Axis** to revolve the object around a line that runs parallel to the Z Axis in the current plan. The object will revolve in the X and Y axes.
- Select **User Defined** to define the axis around which the object will revolve.

 The Axis of Rotation cannot be normal, or perpendicular, to the plane of the selected Face object. If it is, a warning message will display and the object will not be revolved.

4. When User Defined is selected, the **X, Y and Z Direction** fields become active. Type a length value in each field to specify the direction of a custom Axis of Rotation. All three values cannot be 0. No specific unit is used: instead, the ratio between these numbers is used to define an axis of rotation.
5. Specify the **Rotate About Point**, which is the point around which the object will rotate.
6. Specify the **Angle of Rotation**, which is how far around the axis of rotation that the object will rotate. A value of 180° will rotate the object half-way around the axis, while 360° will rotate it in a complete circle.
7. Click OK.



## FILLET/CHAMFER EDGES

  The **Fillet Edges** edit tool allows you to replace an angled edge on a 3D Solid with a curved edge, while the **Fillet All Edges** edit tool replaces all angled edges on a 3D Solid with curved edges. See [Fillet Lines on page 257](#).



  The **Chamfer Edges** edit tool allows you to replace an angled edge on a 3D Solid with a straight beveled edge, while the **Chamfer All Edges** edit tool replaces all angled edges on a 3D Solid with beveled edges. See [Chamfer Lines on page 257](#).

The Fillet Edges and Chamfer Edges edit tools are used in much the same way.

### To fillet an edge

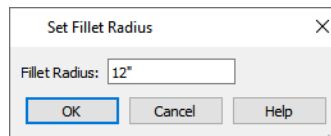
1. Create a camera view of the 3D Solid object you would like to edit.
2. Click on a surface of a 3D Solid and click the **Fillet Lines**  edit button
3. Next, click the **Fillet Radius**  edit button. In the Set Fillet Radius dialog, specify the desired **Fillet Radius** and click OK. If the value is 0, no fillet will be created.



4. To apply the specified radius to all straight edges on the selected 3D Solid, click the **Fillet All Edges**  edit button.
5. To apply a fillet to individual edges of the selected 3D solid, click the **Fillet Edges**  edit button.
6. Move your mouse pointer over a surface edge that you would like to curve. A preview will display, showing the fillet that will be created if you click on that edge.
7. Click on additional surface edges to make them curved, as needed.
8. When you are finished, click the **Main Edit Mode**  edit button or press the Esc key to return to the selected object's main edit toolbar.

Once two lines are filleted, the arc between them can be edited. See [Editing Arc-Based Objects on page 219](#).

## EXPLODE 3D SOLID

 The **Explode 3D Solid** edit tool allows you to explode a selected 3D Solid or Pyramid into a collection of faces. See [Face Objects on page 1016](#).





## USING DIMENSIONS

 Like various other objects, Primitives can be moved using dimensions. 3D Solids, Pyramids, and Faces can also be resized using dimensions. See *Moving Objects Using Dimensions on page 483*.

In order for a particular Dimension Tool to locate Primitives as dimensions are drawn, its defaults must be set to do so. See *Locate Manual Panel on page 454*.

---

## Creating Complex Structures with Primitives

Objects created using the Primitive Tools can be manipulated and combined to produce complex structures. Use the **Union** , **Intersection** , and **Subtract**  edit tools to create unique 3D shapes and combine shapes into **Architectural Blocks**  or use them to create a custom symbol. See *Architectural Blocks on page 1007*, *Union, Intersection, and Subtraction on page 274*, and *Convert to Symbol on page 1002*.

You can also add your custom creations to the library for future use. See *Add to Library on page 965*.

A simple fireplace, for example, can be created by arranging **3D Solids** .

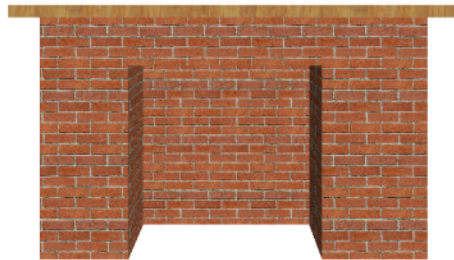

Decorative stone columns can be modeled using **3D Solids** , and the **Union** , and **Subtract**  edit tools.

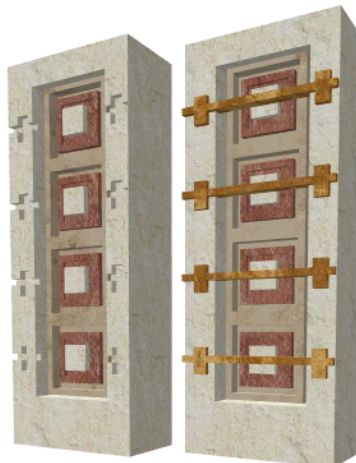



A custom chimney can be designed using **3D Solids**  and **Cylinders**  and the **Union**  and **Subtract**  edit tools.



A detailed model truck can be created using **3D Solids**  and **Cylinders**  and the **Union** , **Intersection** , and **Subtract**  edit tools.



When a primitive has been manipulated using the **Union** , **Intersection**  and **Subtract**  edit tools, it is no longer a primitive that retains its specific shape when edited. Instead, it is considered a 3D Solid. See *3D Solid Specification Dialog on page 1022*.

Structures created using the Primitive Tools can be converted to symbols. See *Convert to Symbol on page 1002*.

---

## 3D Solid Specification Dialog

 To open the 3D Solid Specification dialog, select one or more 3D Solids and click the **Open Object** edit button.

The settings in this dialog are similar to those in the 3D Solid Defaults dialog. See *Default Settings on page 77*.

When you first draw a 3D Solid, the origin of the box is the point where you start drawing it; the width of the box is the X axis dimension.

## 3D SOLID PANEL

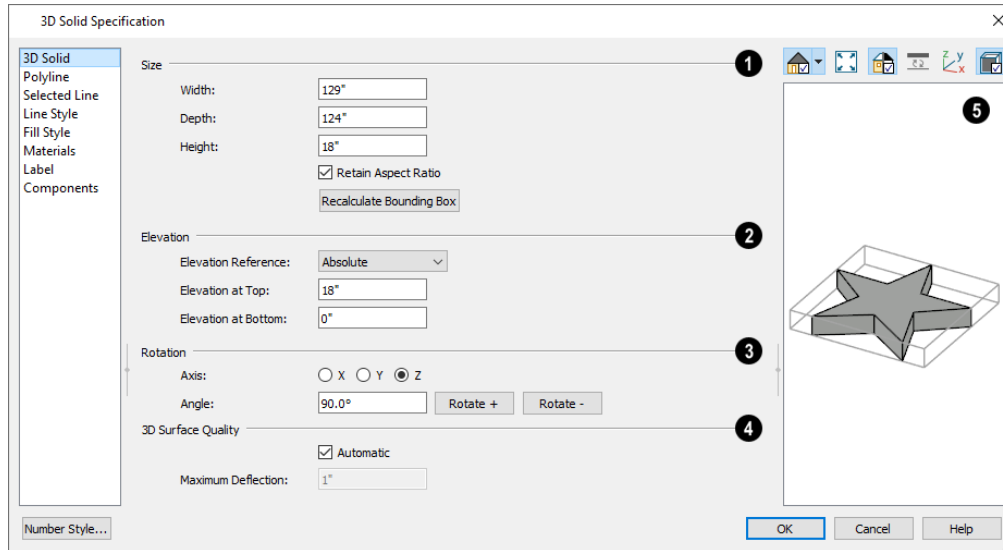

### 1 Size

- Specify the **Width**, **Depth**, and **Height** of the selected object.
- When the selected object was drawn with the **Face** tool, the **Height** will be 0" (mm) and will not be editable. In the 3D Solid Defaults dialog, the Width and Height settings are not available while the Height setting determines the initial height of 3D Solids drawn in plan view.
- When **Retain Aspect Ratio** is checked, the ratio between the shape's Width, Height, and Depth is maintained when it is resized in the specification dialog. Uncheck this box to change these values independently and potentially distort the object's overall shape. This setting is retained when you click OK but does not affect the behavior of the object's edit handles.
- A 3D Solid's bounding box controls the position of its origin point and the orientation of its Y, X, and Z axes (width, depth, and height, respectively). If a 3D Solid is rotated, its bounding box also rotates, affecting how it is reshaped when resized. Click the **Recalculate Bounding Box** button to align the selected 3D Solid's bounding box with the current plan's Cartesian grid and position its origin point at a bottom corner of the bounding box.

### 2 Elevation

- Select the **Elevation Reference** from the drop-down list. This determines where the next two settings are measured from and also affects their setting labels.
- Specify the **to Top** distance, measured from the Elevation Reference to the top of the object.
- Specify the **to Bottom** distance, measured from the Elevation Reference to the bottom of the object.

### 3 Rotation

These settings allow you to rotate the selected shape(s) about the X, Y, and Z axes.

- Select the **X**, **Y**, or **Z Axis** that you want to rotate the shape about.
- Specify the **Angle** to rotate the shape in the text field. 90° is set by default.

- Click the **Rotate +** button to rotate the object around the selected axis in a clockwise direction.
- Click the **Rotate -** button to rotate the object around the selected axis in a counterclockwise direction.

#### **4** 3D Surface Quality

These settings control how any curved surfaces on the selected object are rendered in 3D views.

- Check **Automatic** to have the program define the Maximum Deflection, which is the amount each flat, triangular surface used to represent a curved surface in 3D can deviate from the true curvature of the object. For more information about triangles, see [Edge Smoothing on page 1134](#).
- Specify the **Maximum Deflection** in plan inches (mm). This value is the maximum distance that a point on a triangle can be from the true location of the curved surface. Lower values produce more triangles and a smoother appearance in 3D views.

#### **5** Preview

A preview of the object displays on the right side of the dialog box. See [Dialog Preview Panes on page 22](#).

### **POLYLINE PANEL**

The POLYLINE panel states the length of the object's Perimeter, its Area, and its Volume. See [Polyline Panel on page 317](#).

If the selected solid has any Holes, they will be subtracted from the Area and Volume values. See [Polyline Holes on page 232](#).

### **SELECTED LINE/ARC PANEL**

The SELECTED LINE panel is available when the selected edge is a line as opposed to an arc. For more information, see [Line Panel on page 304](#).

The SELECTED ARC panel is available when the selected edge has been converted to an arc. For more information, see [Arc Panel on page 312](#).

See, too, [Selected Edge on page 212](#) and [Change Line/Arc on page 256](#).

### **LINE STYLE PANEL**

For information about the settings on this panel, see [Line Style Panel on page 305](#).

### **FILL STYLE PANEL**

The settings on the FILL STYLE panel affect the appearance of the selected shape in plan view. See [Fill Style Panel and Dialogs on page 193](#).

### **MATERIALS PANEL**

For information about the settings on this panel, see [Materials Panel on page 1055](#).

### **LABEL PANEL**

3D Solid labels display when the "Polylines 3D, Labels" layer is turned on and use the Text Style assigned to that layer. The Automatic Label for 3D solids is blank, but you can specify a custom label. For information about the settings on this panel, see [Label Panel on page 700](#).



## COMPONENTS PANEL

The information on the COMPONENTS panel can be used in the materials list. For more information, see [Components Panel on page 1330](#).

# Sphere Specification Dialog

Select a sphere and click the **Open Object** edit button to open the Sphere Specification dialog.

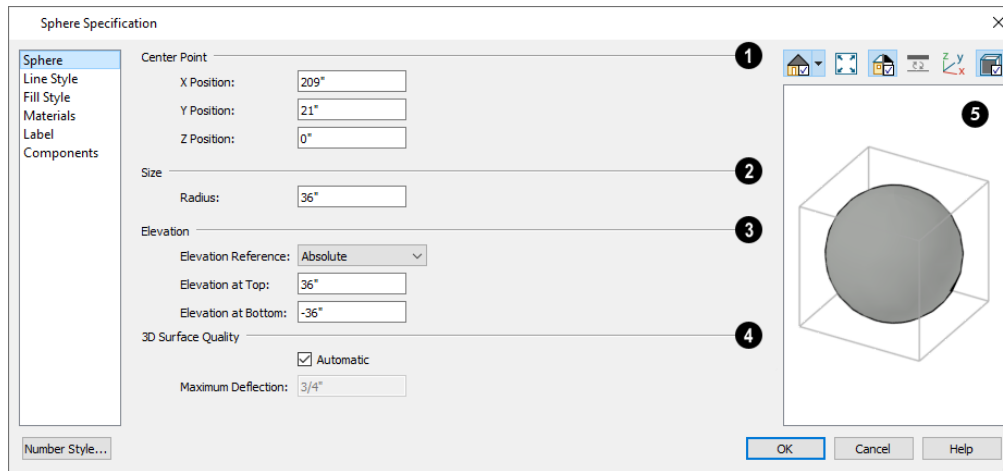

### 1 Center Point

Specify the **Center Point** of the selected sphere in relation to the origin point of your plan. See [Entering Coordinates on page 166](#).

- Enter the **X**, **Y**, and **Z Position** coordinates of the sphere's center point.

### 2 Size

Specify the **Radius** of the selected sphere.

### 3 Elevation

- Select the **Elevation Reference** from the drop-down list. This determines where the next two settings are measured from and also affects their setting labels.
- Specify the **to Top** distance, measured from the Elevation Reference to the top of the sphere.
- Specify the **to Bottom** distance, measured from the Elevation Reference to the bottom of the sphere.

### 4 3D Surface Quality

These settings control how any curved surfaces on the selected object are rendered in 3D views.

- Check **Automatic** to have the program define the Maximum Deflection, which is the amount each flat, triangular surface used to represent a curved surface in 3D can deviate from the true curvature of the object. For more information about triangles, see [Edge Smoothing on page 1134](#).

- Specify the **Maximum Deflection** in plan inches (mm). This value is the maximum distance that a point on a triangle can be from the true location of the curved surface. Lower values produce more triangles and a smoother appearance in 3D views.

### **5 Preview**

A preview of the sphere displays on the right side of the dialog box. See *Dialog Preview Panes on page 22*.

### **LINE STYLE PANEL**

For information about the settings on this panel, see *Line Style Panel on page 305*.

### **FILL STYLE PANEL**

The settings on the FILL STYLE panel affect the appearance of the selected sphere in plan view. See *Fill Style Panel and Dialogs on page 193*.

### **MATERIALS PANEL**

For information about the settings on this panel, see *Materials Panel on page 1055*.

### **LABEL PANEL**

Primitive labels display when the “Polylines 3D, Labels” layer is turned on and use the Text Style assigned to that layer. The Automatic Label for Primitives is blank, but you can specify a custom label. For information about the settings on this panel, see *Label Panel on page 700*.

### **COMPONENTS PANEL**

The information on the COMPONENTS panel can be used in the materials list. For more information, see *Components Panel on page 1330*.

---

## **Cylinder Specification Dialog**



Select a cylinder and click the **Open Object** edit button to open the Cylinder Specification dialog.

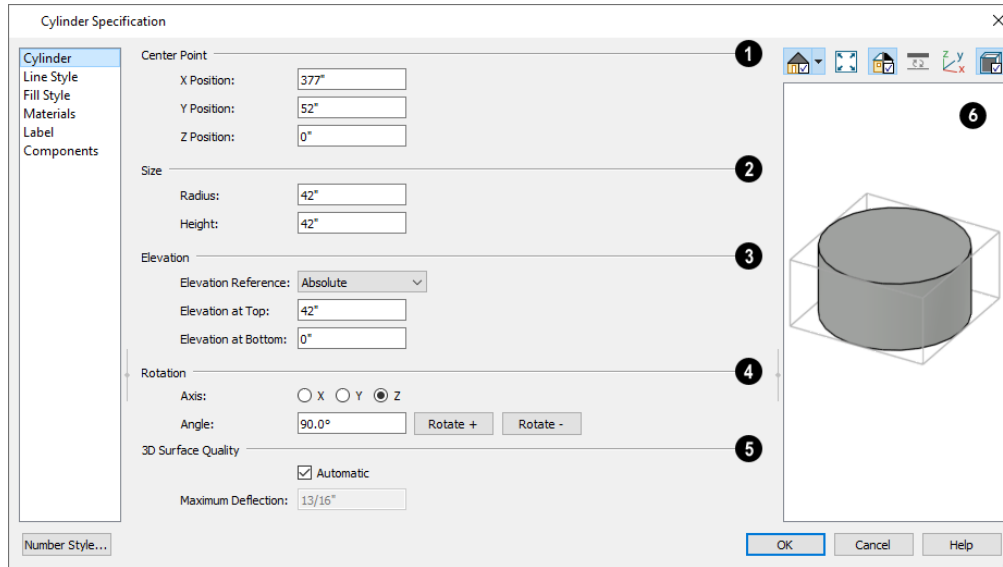

### 1 Center Point

Specify the **Center Point** of the selected cylinder's base in relation to the origin point of your plan. See [Entering Coordinates on page 166](#).

- Enter the **X, Y, and Z Position** coordinates of the cylinder's center point.

### 2 Size

Specify the **Radius** and **Height** of the selected cylinder.

### 3 Elevation

- Select the **Elevation Reference** from the drop-down list. This determines where the next two settings are measured from and also affects their setting labels.
- Specify the **to Top** distance, measured from the Elevation Reference to the top of the object.
- Specify the **to Bottom** distance, measured from the Elevation Reference to the bottom of the object.

### 4 Rotation

The **Rotation** settings allow you to rotate the selected cylinder about the X, Y, and Z axes. See [3D Drafting on page 13](#).

- Select the **X, Y, or Z Axis** as the axis around which the cylinder will rotate.
- Specify the **Angle** to rotate the cylinder in the text field. The default value is 90°.
- Click the **Rotate +** button to rotate the cylinder around the selected axis in a clockwise direction.
- Click the **Rotate -** button to rotate the cylinder around the selected axis in a counterclockwise direction.

### 5 3D Surface Quality

These settings control how any curved surfaces on the selected object are rendered in 3D views.

- Check **Automatic** to have the program define the Maximum Deflection, which is the amount each flat, triangular surface used to represent a curved surface in 3D can deviate from the true curvature of the object. For more information about triangles, see [Edge Smoothing on page 1134](#).
- Specify the **Maximum Deflection** in plan inches (mm). This value is the maximum distance that a point on a triangle can be from the true location of the curved surface. Lower values produce more triangles and a smoother appearance in 3D views.

## 6 Preview

A preview of the cylinder displays on the right side of the dialog box. See [Dialog Preview Panes on page 22](#).

## LINE STYLE PANEL

For information about the settings on this panel, see [Line Style Panel on page 305](#).

## FILL STYLE PANEL

The settings on the FILL STYLE panel affect the appearance of the selected cylinder in plan view. See [Fill Style Panel and Dialogs on page 193](#).

## MATERIALS PANEL

For information about the settings on this panel, see [Materials Panel on page 1055](#).

## LABEL PANEL

Primitive labels display when the “Polylines 3D, Labels” layer is turned on and use the Text Style assigned to that layer. The Automatic Label for Primitives is blank, but you can specify a custom label. For information about the settings on this panel, see [Label Panel on page 700](#).

## COMPONENTS PANEL

The information on the COMPONENTS panel can be used in the materials list. For more information, see [Components Panel on page 1330](#).

---

# Cone Specification Dialog



Select a cone and click the **Open Object** edit button to open the Cone Specification dialog.

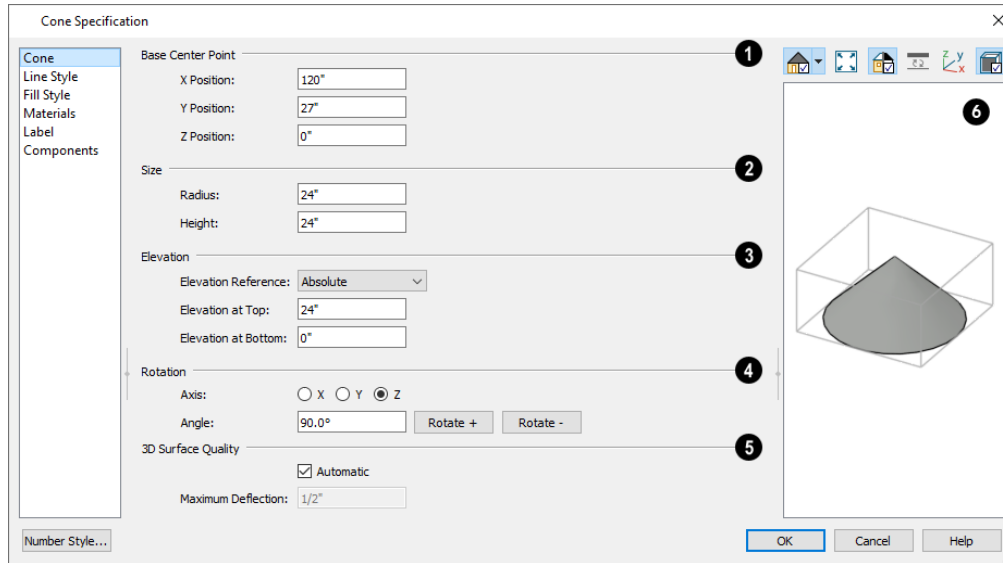

### 1 Base Center Point

Specify the **Base Center Point** of the selected cone in relation to the origin point of your plan. See [Entering Coordinates on page 166](#).

- Enter the **X**, **Y**, and **Z Position** coordinates of the center point of the cone's base.

### 2 Size

Specify the **Radius** and **Height** of the selected cone.

### 3 Elevation

- Select the **Elevation Reference** from the drop-down list. This determines where the next two settings are measured from and also affects their setting labels.
- Specify the **to Top** distance, measured from the Elevation Reference to the top of the object.
- Specify the **to Bottom** distance, measured from the Elevation Reference to the bottom of the object.

### 4 Rotation

The **Rotation** settings allow you to rotate the selected cone about the X, Y, and Z axes. See [3D Drafting on page 13](#).

- Select the **X**, **Y**, or **Z Axis** as the axis around which the cone will rotate.
- Specify the **Angle** to rotate the cone in the text field. The default value is 90°.
- Click the **Rotate +** button to rotate the cone around the selected axis in a clockwise direction.
- Click the **Rotate -** button to rotate the cone around the selected axis in a counterclockwise direction.

### 5 3D Surface Quality

These settings control how any curved surfaces on the selected object are rendered in 3D views.

- Check **Automatic** to have the program define the Maximum Deflection, which is the amount each flat, triangular surface used to represent a curved surface in 3D can deviate from the true curvature of the object. For more information about triangles, see [Edge Smoothing on page 1134](#).
- Specify the **Maximum Deflection** in plan inches (mm). This value is the maximum distance that a point on a triangle can be from the true location of the curved surface. Lower values produce more triangles and a smoother appearance in 3D views.

## 6 Preview

A preview of the cone displays on the right side of the dialog box. See [Dialog Preview Panes on page 22](#).

## LINE STYLE PANEL

For information about the settings on this panel, see [Line Style Panel on page 305](#).

## FILL STYLE PANEL

The settings on the FILL STYLE panel affect the appearance of the selected cone in plan view. See [Fill Style Panel and Dialogs on page 193](#).

## MATERIALS PANEL

For information about the settings on this panel, see [Materials Panel on page 1055](#).

## LABEL PANEL

Primitive labels display when the “Polylines 3D, Labels” layer is turned on and use the Text Style assigned to that layer. The Automatic Label for Primitives is blank, but you can specify a custom label. For information about the settings on this panel, see [Label Panel on page 700](#).

## COMPONENTS PANEL

The information on the COMPONENTS panel can be used in the materials list. For more information, see [Components Panel on page 1330](#).

---

# Pyramid Specification Dialog



Select a pyramid and click the **Open Object** edit button to open the Pyramid Specification dialog.

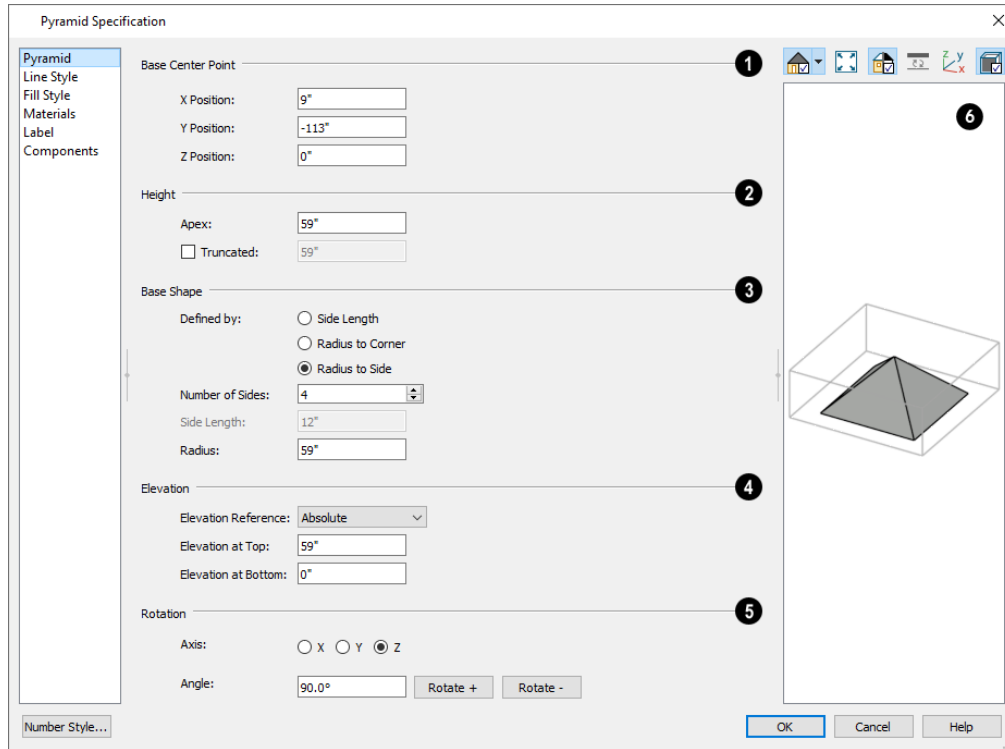

### 1 Base Center Point

Specify the **Base Center Point** of the selected pyramid in relation to the origin point of your plan. See [Entering Coordinates on page 166](#).

- Enter the **X**, **Y**, and **Z Position** coordinates of the center point of the pyramid’s base.

### 2 Height

Specify the **Height** of the selected pyramid.

- Specify the height of the **Apex**, measured from the base to the peak.
- Check **Truncated** to cut off the top of the pyramid and create a flat top.
- Specify the **Height** of a truncated pyramid, measured from the base to the flat truncated top.

### 3 Base Shape

Specify the selected pyramid’s **Base Shape**.

- Specify what you would like the pyramid’s size to be **Defined By**:
- Select **Side Length** to enable the Side Length field to the right and specify the length of each side of the pyramid’s base.
- Select **Radius to Corner** to define the distance from the center point of the pyramid’s base to any of its corners.
- Select **Radius to Side** to define the distance from the center point of the pyramid’s base to the midpoint of any of its edges.
- Specify the **Number of Sides** that the selected pyramid has. The default value is 4.

- Specify the **Side Length**, which is the corner to corner length of one each side of the pyramid's base. Only available when **Define Polyline by Side Length** is selected to the left.
- Specify the **Radius** of the pyramid's base, as measured from its center point to a corner or to the midpoint of a side. Only available when **Define Polygon by Radius to Corner** or **Radius to Side** is selected.

#### 4 Elevation

- Select the **Elevation Reference** from the drop-down list. This determines where the next two settings are measured from and also affects their setting labels.
- Specify the **to Top** distance, measured from the Elevation Reference to the top of the object.
- Specify the **to Bottom** distance, measured from the Elevation Reference to the bottom of the object.

#### 5 Rotation

The **Rotation** settings allow you to rotate the selected pyramid about the X, Y, and Z axes. See *3D Drafting on page 13*.

- Select the **X, Y, or Z Axis** as the axis around which the pyramid will rotate.
- Specify the **Angle** to rotate the pyramid in the text field. The default value is 90°.
- Click the **Rotate +** button to rotate the pyramid around the selected axis in a clockwise direction.
- Click the **Rotate -** button to rotate the pyramid around the selected axis in a counterclockwise direction.

#### 6 Preview

A preview of the pyramid displays on the right side of the dialog box. See *Dialog Preview Panes on page 22*.

### LINE STYLE PANEL

For information about the settings on this panel, see *Line Style Panel on page 305*.

### FILL STYLE PANEL

The settings on the FILL STYLE panel affect the appearance of the selected pyramid in plan view. See *Fill Style Panel and Dialogs on page 193*.

### MATERIALS PANEL

For information about the settings on this panel, see *Materials Panel on page 1055*.

### LABEL PANEL

Primitive labels display when the “Polylines 3D, Labels” layer is turned on and use the Text Style assigned to that layer. The Automatic Label for Primitives is blank, but you can specify a custom label. For information about the settings on this panel, see *Label Panel on page 700*.

### COMPONENTS PANEL

The information on the COMPONENTS panel can be used in the materials list. For more information, see *Components Panel on page 1330*.



---

## General Shapes



Items in the Chief Architect Core Catalogs> Shapes library catalog allow you to create a variety of custom objects using basic geometric shapes. These shapes can be used individually or combined to create a wide variety of custom objects.

General Shape objects are placed and edited much like other library objects. See [Editing Box-Based Objects on page 232](#).

---

## Soffits



Soffits typically fill the space between the tops of wall cabinets and the ceiling, but they are very versatile and can be used to create almost any other object that can be modeled as a 3D box. Select **Build> Cabinet> Soffit** to activate this tool.

### SOFFIT DEFAULTS



The default settings for soffits are set in the Soffit Defaults dialog. The settings in this dialog are similar to those in the Soffit Specification dialog. See [Soffit Specification Dialog on page 1034](#).

When a soffit is created, it is placed on the “Cabinets, Soffits” layer. See [Layer Attributes on page 177](#).

For best results when placing soffits above wall cabinets:

- The default soffit should be the same width as and 1" (20mm) deeper than the default wall cabinet. See [Cabinet Defaults on page 618](#).
- The default soffit **Floor to Bottom** value should equal the sum of the default wall cabinet’s Floor to Bottom value plus its Height. See [General Panel on page 1034](#).
- The default soffit **Height** should be equal to or greater than the space between the ceiling and the top of the wall cabinets.

If the sum of the default soffit’s Floor to Bottom value and Height is larger than the ceiling height of the room in which a soffit is placed, the Floor to Bottom value will be retained and its Height will be adjusted so that it fits under the ceiling.

The maximum soffit width is 250 feet (48m), and the minimum width is 1/16" (1 mm).

Once a soffit is placed in a plan, you can change its size and position to meet a variety of needs. See [Editing Box-Based Objects on page 232](#).

### PLACING SOFFITS

Soffits can be created in both 2D and 3D views by simply clicking with the **Soffit**  tool active. See [Click-to-Create on page 164](#).

To create a corner soffit, click as close to an inside wall corner as possible. A corner soffit retains its shape when it is moved, edited, or copied.

When positioned against a wall in a room, soffits will automatically display any moldings present in that room that are at the same height as the soffit. Soffits can also have custom molding profiles assigned to them. See [Moldings Panel on page 446](#).

When positioned against the ceiling in a room, a soffit will prevent the Ceiling Finish layers directly above it from generating in 3D. See [Lowered Ceilings on page 434](#).

## CALCULATING MATERIALS ON SOFFITS

The number of bricks, tiles, shingles, shakes or other materials applied to a soffit is calculated using the following rules:

- If the soffit depth is less than the larger of 4 inches (10 mm) or 1 ½ times the material thickness, then only the front area of the soffit is used. Thus if a soffit is 48"x48"x4" thick, and the Dark Red brick material is used (3"x 8" with 3/8" mortar joint), the front of the soffit is 48"x48"=2304 square inches. Including the mortar joint, each brick requires 3 3/8" x 8 3/8" = 28.26 square inches. 2304 sq. in. divided by 28.26 sq. in. per brick gives 81.5 bricks.
- If the soffit depth is greater than both 4 inches (10 mm) and 1 ½ times the material thickness, then the surface areas of the soffit back, sides and top are used in addition to the front, if these surfaces are not attached to a wall or other soffit. However, only those portions of the sides, top and bottom remaining after subtracting twice the material thickness are used. So, for Dark Red brick, which has a depth of 4", the sides, top and bottom surface areas cannot contribute to the brick count unless the soffit depth is greater than 8 inches.
- If surface materials such as brick are applied to a large soffit, the soffit center is assumed to be hollow, with only a single layer of the material applied to each applicable face.
- For shingles and shakes, the overlap amount should be subtracted from the height, as opposed to brick or tile, where the joint width is added to the size.
- For materials in the area category, the soffit area calculation above is used, with the material thickness treated as zero.
- For materials in the volume, concrete or earth categories, the true volume of the soffit is used.

## Soffit Specification Dialog

To open the Soffit Specification dialog, select the soffit and click the **Open Object** edit button or double-click on a soffit using the **Soffit**  tool.

The settings in this dialog are similar to those in the Soffit Defaults dialog, but affect only the selected object(s).

The Soffit Specification dialog has the following panels:

### GENERAL PANEL

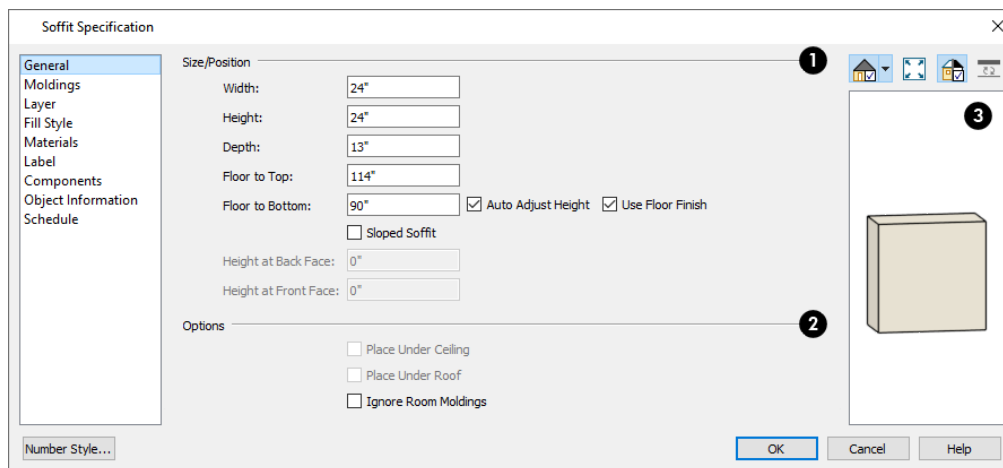

#### 1 Size/Position

Define the **Size** and **Position** of the selected soffit relative to the floor or terrain.

- Specify the **Width** of the soffit.
- Define the vertical **Height** of the soffit.
- Define the **Depth**, which is the distance between the front and the back of the soffit. When selected in plan view, the front of a soffit has a “V,” and the back of the soffit has a triangular rotation handle.
- If the selected soffit is a corner soffit, the **Width** controls its left side width, and **Depth** controls its right side width.
- Specify the distance from **Floor to Top** of the soffit.
- Specify the distance from **Floor to Bottom** of the soffit.
- When the selected soffit is outside a room, its Floor to Bottom height is measured relative to the terrain. Check **Auto Adjust Height** to maintain the same distance above the terrain if the soffit is moved to a location with different terrain height. Uncheck this to maintain the same absolute height regardless of the terrain below. When **Auto Adjust Height** is checked, the Floor to Bottom value may automatically adjust if the soffit is moved.
- Check **Use Floor Finish** to measure the Floor to Bottom distance from the surface of the floor finish. When unchecked, this height is measured from the subfloor. Only available when Auto Adjust Height is checked.
- Check **Sloped Soffit** to slope the soffit vertically from the back up towards the front. This may become checked automatically if you check Place Under Ceiling or Place Under Roof, below. When you specify a soffit as sloped, the available options on this panel change. See *General Panel - Sloped Soffits on page 1035*, below.
- The **Height at Back Face** and **Front Face** settings become enabled when Sloped Soffit is checked. See *General Panel - Sloped Soffits on page 1035*, below.

## 2 Options

- Check **Place Under Ceiling** to adjust the soffit’s height so its top contacts the ceiling above. If the soffit is below a sloped ceiling plane, Sloped Soffit will become checked and the Height at Back and Front Face will adjust to match the pitch. Not available in the Soffit Defaults dialog, or if the soffit is not below a ceiling.
- Check **Place Under Roof** to adjust the soffit’s height so its top contacts the bottom of the roof above. Provided that the roof above does not have a pitch of 0, Sloped Soffit will become checked and the Height at Back and Front Face will adjust to match the pitch. Not available in the Soffit Defaults dialog, or if there is no roof above the soffit.
- Check **Ignore Room Moldings** to prevent the selected soffit from displaying moldings assigned to the room that it is placed in. See *Room Moldings on page 436*.
- Check **Include in Schedule** to include the selected soffit in a Cabinet Schedule. See *Cabinet Schedules on page 630*.

## 3 Preview

A preview of the soffit displays on the right side of the dialog box. See *Dialog Preview Panes on page 22*.

### GENERAL PANEL - SLOPED SOFFITS

When a soffit is specified as sloped, the available options on the GENERAL panel of the Soffit Specification dialog change.

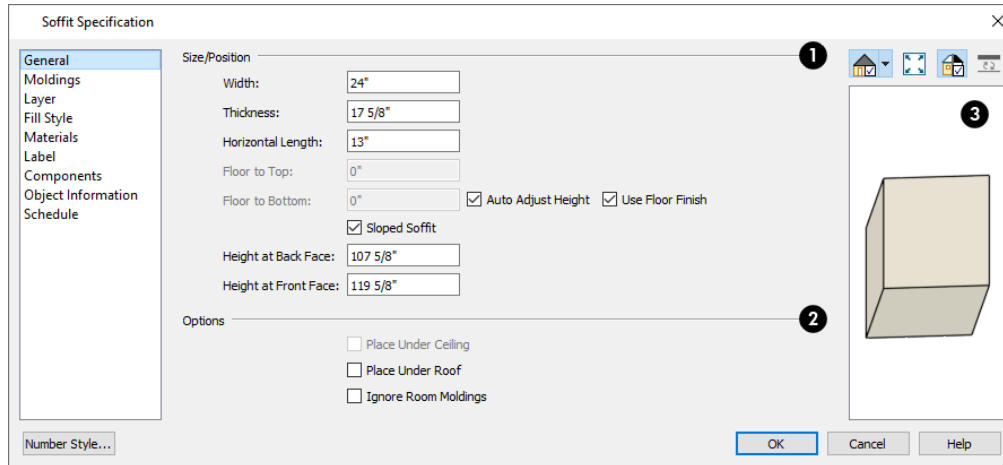

- **Width** is measured left to right across the soffit, parallel to the front of the soffit.
- **Thickness** is the top-to-bottom height of the front and back faces of the soffit.
- **Horizontal Length** is measured from back to front in plan view. When a soffit is sloped, this measurement is not the actual length of the soffit’s bottom or top edge. It cannot, for example, be used to determine the length of a sloped beam.

Both the front and back heights of a sloped soffit must be defined. Checking Place Under Ceiling or Place Under Roof will automatically adjust these values to match the slope of the ceiling or roof plane above.

- **Height at Back Face** is measured from the finished floor to the lowest point at the back of the soffit.
- **Height at Front Face** is measured from the finished floor to the underside of the soffit at the upper end.

## MOLDINGS PANEL

The settings on the MOLDINGS panel allow you to assign one or more horizontal moldings around the selected soffit. For information about the settings on this panel, see [Moldings // Profiles / Rails / Panels on page 927](#).

## LAYER PANEL

For information about the settings on this panel, see [Layer Panel on page 186](#).

## FILL STYLE PANEL

The settings on the FILL STYLE panel affect the selected soffit’s appearance in plan view. For information about the settings on this panel, see [Fill Style Panel and Dialogs on page 193](#).

## MATERIALS PANEL

For information about the settings on this panel, see [Materials Panel on page 1055](#).

## LABEL PANEL

Soffit labels display in plan view when the “Cabinets, Labels” layer is turned on and use the Text Style assigned to that layer. The Automatic Label for Soffits is blank, but you can specify a custom label. See [Cabinet Labels on page 630](#).

For more information about the settings on this panel, see [Label Panel on page 700](#).

## COMPONENTS PANEL

The information on the COMPONENTS panel can be used in the materials list. For more information, see [Components Panel on page 1330](#).

## OBJECT INFORMATION PANEL

The information entered on the OBJECT INFORMATION panel can be used in schedules and the materials list. For more information, see [Object Information Panel on page 1331](#).

## SCHEDULE PANEL

The settings on the SCHEDULE panel determine which schedule categories the selected soffit is included in. See [Schedule Panel on page 704](#).

---

# Floor and Wall Material Regions

**Floor and Wall Material Regions** allow you to create areas within a wall or floor that use different materials than the parent object. There are three types of Material Regions:

Material Regions are CAD-based objects composed of one or more layers. The thickness of these layers and their materials can be set in the Material Region Specification dialog. See [Material Region Specification Dialog on page 1038](#).

By default, Material Regions use the materials specified in the Floor and Wall Material Region Defaults dialogs. See [Default Settings on page 77](#).

By default, a Material Region cuts into the finish layers of its parent object and replaces those layers with its own within its perimeter; it can, however, be affixed to the parent's surface instead if you prefer.

In general, Material Regions are created and edited in the same manner that other closed polylines are. Bear in mind that their shapes can only be edited in the view type in which they were created and that Floor Material Regions cannot be moved in cross section/elevation views. See [Polylines on page 316](#) and [Editing Closed Polyline-Based Objects on page 228](#).

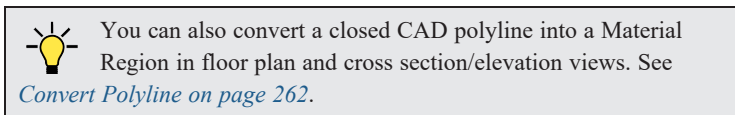

Like most other architectural objects, a Material Region can be added to the library. Its material layers and the information in its specification dialog are saved; however, the shape of its polyline is not. See [Add to Library on page 965](#).

Material Regions can span multiple parent objects; however, for best results the parent objects should have structural, or Main, layer surfaces that are in alignment.

## CUSTOM BACKSPASHES

 To create a Custom Backsplash, select **Build> Cabinet> Custom Backsplash**. Custom Backsplashes are drawn on the vertical surface of a wall and are always drawn in camera or elevation views. If you create one by clicking once, it will behave the way a Wall Material Region would, provided that no cabinets or appliances are positioned against the wall.

The initial attributes of Custom Backsplashes are set in the Custom Backsplash Defaults dialog. See [Cabinet Defaults on page 618](#).

If any cabinets and/or appliances are present, a Custom Backsplash will:

- Seek to fill the area between any base cabinets or floor appliances against that wall surface and any wall cabinets and/or windows above them.
- If nothing is above any base cabinets, it will fill the area between the cabinets and the ceiling; if nothing is below any wall cabinets, it will fill the area between the cabinets and the floor.
- Replace the backsplash associated with any base or wall cabinets.

Like Wall Material Regions, Custom Backsplashes set to cut the finish layers of their parent object will replace the layers of the wall between itself and the wall's Main Layer with its own layers.

## FLOOR MATERIAL REGIONS

 To create a Floor Material Region, select **Build> Floor> Material Region**. Floor Material Regions must be drawn within a room area and are always drawn in plan view. If you create one by clicking once, it will fill the extents of the room.

Floor Material Regions set to cut the finish layers of their parent object will replace the layers of that floor's Finish Definition with its own layers. See [Floor and Ceiling Platform Definitions on page 429](#).

## WALL MATERIAL REGIONS

 To create a Wall Material Region, select **Build> Wall> Material Region**. Wall Material Regions are drawn on the vertical surface of a wall and are always drawn in camera or elevation views. If you create one by clicking once, it will cut around doors, windows, and fireplaces but will otherwise fill the entire surface of the parent wall.

Wall Material Regions set to cut the finish layers of their parent object will replace the layers of the wall between itself and the wall's Main Layer with its own layers. See [Wall Type Definitions on page 384](#).

---

# Material Region Specification Dialog

 Select a Material Region or a Custom Backsplash and click the **Open Object** edit button to open the Material Region or Custom Backsplash Specification dialog.

The settings in these two dialogs are also found in the Material Region Defaults dialogs, and most of its panels are also found in the specification dialogs for a variety of other CAD-based objects.

## STRUCTURE PANEL

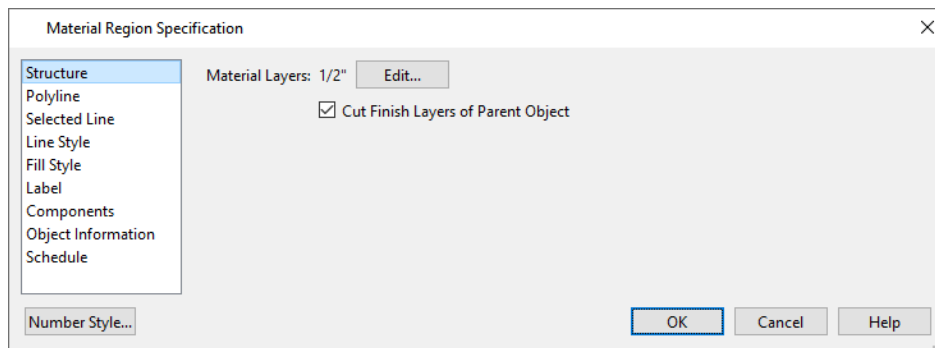

- The total thickness of the **Material Layers** displays here for reference.
- Click the **Edit** button to open the Material Layers Definition dialog. See *Material Layers Definition Dialogs on page 1040*.
- Uncheck **Cut Finish Layers of Parent Object** to fix the selected Material Region to the surface of its parent floor platform or wall. When checked, it cuts into the finish layers of the polyline's parent object and replaces those layers with its own within its perimeter.

## **POLYLINE PANEL**

The POLYLINE panel indicates the length of the region's **Perimeter** and its enclosed **Area**. See *Polyline Panel on page 317*. If the selected region has any Holes in it, they will be subtracted from the **Area** and **Volume** values. See *Polyline Holes on page 232*.

## **SELECTED LINE/ARC PANEL**

The SELECTED LINE panel is available when the selected edge is a line as opposed to an arc. See *Line Panel on page 304*. The SELECTED ARC panel is available when the selected edge has been converted into an arc. See *Arc Panel on page 312*. See, too, *Selected Edge on page 212* and *Change Line/Arc on page 256*.

## **LINE STYLE PANEL**

For information about the settings on this panel, see *Line Style Panel on page 305*.

## **FILL STYLE PANEL**

The FILL STYLE panel is only available for Floor Material Regions. For information about the settings on this panel, see *Fill Style Panel and Dialogs on page 193*.

## **LABEL PANEL**

Material Region labels display in floor plan and cross section/elevation views when the "Polylines 3D, Labels" layer is turned on and use the Text Style assigned to that layer. The Automatic Label for Material Regions is blank, but you can specify a custom label.

For information about the settings on this panel, see *Label Panel on page 700*.

## **COMPONENTS PANEL**

The information on the COMPONENTS panel can be used in the materials list. For more information, see *Components Panel on page 1330*.

## **OBJECT INFORMATION PANEL**

The information entered on the OBJECT INFORMATION panel can be used in schedules and the materials list. For more information, see *Object Information Panel on page 1331*.

## **SCHEDULE PANEL**

The settings on the SCHEDULE panel determine which schedule categories the selected object is included in. See *Schedule Panel on page 704*.

## Material Layers Definition Dialogs

The Material Layers Definition dialogs allow you to define the layers that make up wall, floor, ceiling, slab, and roof assemblies. The names of these dialogs vary and are determined by the type of object or component being edited. They include:

- Backsplash Layers Definition
- Ceiling Structure Definition
- Ceiling Finish Definition
- Floor Structure Definition
- Floor Finish Definition
- Roof Surface Definition
- Roof Structure Definition
- Roof Ceiling Finish Definition

See *Floor and Wall Material Regions on page 1037*, *Floor and Ceiling Platforms on page 428*, and *Roof Planes on page 804*.

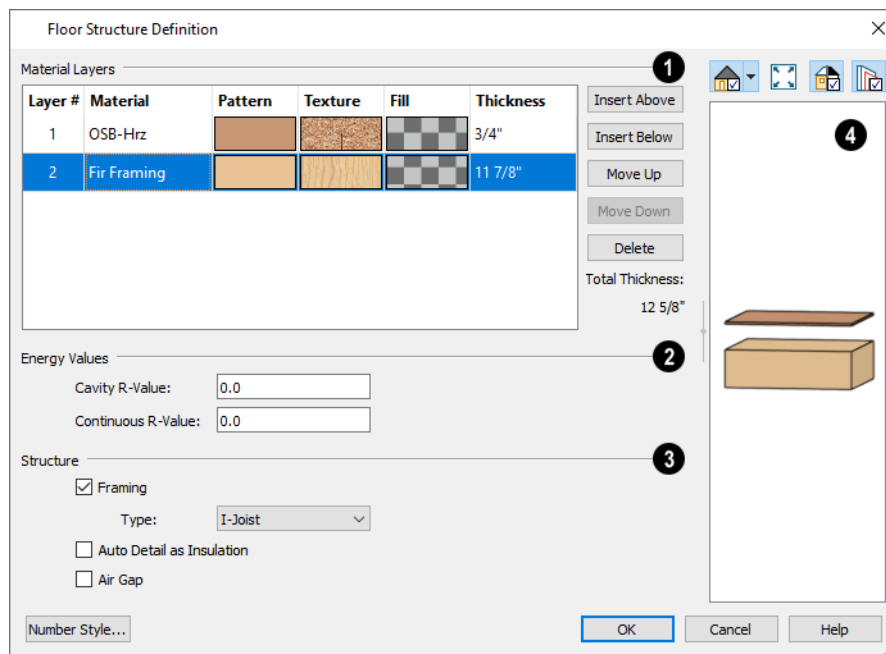

### 1 Layers

The selected assembly's layers are numbered and listed from the top of the structure to its bottom. To select a layer for editing, click in its row.

- Click in the **Material**, **Pattern**, or **Texture** column to open the Select Material dialog and choose a material for the selected layer. See *Select Material/Library Object Dialog on page 1056*.
- Click in the **Fill** column to open the Layer Fill Style dialog and define a fill style for the selected layer. This fill style is applied when the **Auto Detail** tool is used in a cross section view. See *Fill Styles on page 192*.



- Click in the **Thickness** column to type the selected layer's thickness or depth. Very thin layers can be created, but for best results avoid using a thickness of 0. For very small values, it can be helpful to temporarily change the dialog number format: click the **Number Style** button.
- The **Total Thickness** of the assembly displays to the right as a reference.
- Select a **Structure Type** from the drop-down list. Only available when the selected material is a Framing type. See *Framing Materials and Types on page 881*.

The buttons to the right of the table allow you to reorganize the assembly's layers.

- Click the **Insert Above** button to create a new layer directly above the currently selected layer in the assembly.
- Click the **Insert Below** button to create a new layer directly below the currently selected layer in the assembly.
- Click the **Move Up** button to swap the selected layer's position with that of the layer above it. Not available for the top-most layer of the assembly.
- Click the **Move Down** button to swap the selected layer's position with that of the layer below it. Not available for the bottom-most layer of the assembly.
- Click **Delete** to remove the selected layer.

## 2 Energy Values

Specify the selected Floor Structure or Ceiling Structure's energy values, which are used when exporting to REScheck. Only available for Floor Structure and Ceiling Structure Definitions. See *Export to REScheck on page 1240*.

- Specify the structure's **Cavity R-Value**, which is the R-value of its cavity insulator: most commonly, the insulation between wood or metal joists.
- Specify the **Continuous R-Value**, which is the R-value of continuous insulators such as rigid foam sheets.

## 3 Structure

Specify whether the selected layer has special structural attributes.

- Check **Framing** to produce framing in the selected layer when framing is generated for the selected structural assembly's type. See *Build Framing Dialog on page 860*.
- Select the framing **Type** from the drop-down list. See *Displaying Framing on page 879*.
- In the Roof Structure Definition dialog, you can also check **Include Structural Purlins** to include structural purlins that run between and perpendicular to the rafters. Only available when Framing is checked, above.

- In the Roof Surface and Roof Ceiling Finish Definition dialogs, you can instead check **Include Purlins** to produce non-structural framing that runs perpendicular to the roof or ceiling plane's rafters. In either case:
  - Select the purlin framing **Type** from the drop-down list. See *Displaying Framing on page 879*.
  - Specify the on-center **Spacing** of purlins, measured along the direction of the pitch.
  - Specify the vertical **Thickness** and the **Width** of the purlins.
  - Check **Max Length**, then specify the maximum allowed length for non-structural purlins used in Roof Surface and Ceiling Finish Definitions only.
  - Specify the **Bottom Run Offset**, which is the distance of from the lowest purlin to the rafter ends, measured along the pitch of the roof or ceiling rather than horizontally.
  - Specify the **Top Run Offset**, which is the distance from the highest purlin to the ridge, measured along the pitch of the roof or ceiling.
  - Check **Use Equal Spacing** to space purlins equally between the bottom and top runs, using as close to the Spacing value specified above as possible.
  - Select whether Structural Purlins are **Flush Against the Exterior** or top edge of the rafters, or the **Interior** or bottom edge of the rafters. Only available in the Roof Structure Definition dialog.
- Check **Auto Detail as Insulation** to generate Insulation boxes in the selected layer when **Auto Detail**  is used in cross section views. See *Detailing Cross Section/Elevation Views on page 1094*.
- Check **Air Gap** to prevent the selected layer from displaying in 3D views or being calculated in the Materials List. See *Creating an Accurate Materials List on page 1305*.

#### 4 Preview

A preview of the selected assembly displays here. See *Dialog Preview Panes on page 22*.

- By default, a gap is shown between each of the assembly layers. Click the **Explode Layers**  button to remove or restore these gaps.

---

## Distributed Objects

 The **Distributed Object** tools allow you to place multiple copies of an object in an evenly spaced array, either within a region or along a path. Select **Build> Distributed Object** to access these tools.

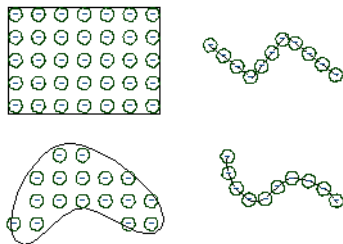

### To create distributed objects

1. Select **Build> Distributed Object** and choose the desired Distributed Object tool.
2. Distribution regions are drawn like other closed polyline and spline-based objects.

- Click once to place a region with endpoints that form a 10' (4 m) square.
  - Click and drag from end to end to draw a region sized as needed.
3. Distribution paths are drawn like other open polyline and spline-based objects.
    - Click and drag from end to end to draw one or more connected lines or spline segments.
  4. Select the region and click the **Open Object**  edit button.
  5. In the Distribution Region Specification dialog:
    - Select the object to be distributed within the region.
    - Specify the distributed objects' spacing, orientation and positioning.
    - Click **OK** to close the dialog. See *Distribution Region/Path Specification Dialogs on page 1043*.

Once created, Distribution Regions and Paths can be edited into nearly any shape you require. See *Editing Closed Polyline-Based Objects on page 228* and *Editing Spline-Based Objects on page 235*.

 You can replace the object assigned to a Distribution Region or Path by applying a new one directly from the library. See *Replace From Library on page 976*.

All objects associated with a Distribution Path or Region will be listed in a schedule or materials list for a particular room if the center point of the path or region is located inside the room. If the center point of the path or region is not located in the room, none of its objects will be listed. See *Create Schedule from Room on page 683* and *Calculate Materials in Room on page 1304*.

## EXPLODE DISTRIBUTED OBJECTS

 Objects grouped in a Distribution Region or Path cannot be individually selected. You can, however, click the **Explode Distributed Object** edit button to separate a region or path into its individual components. Once exploded, a Distribution Region or Path cannot be regrouped.

---

## Distribution Region/Path Specification Dialogs

 Select a Distribution Region or Path and click the **Open Object** edit button to open the Distribution Region or Distribution Path Specification dialog.

The settings in these two dialogs are similar and most panels are also found in the specification dialogs for a variety of other CAD-based objects.

## DISTRIBUTED OBJECT PANEL - DISTRIBUTION REGION

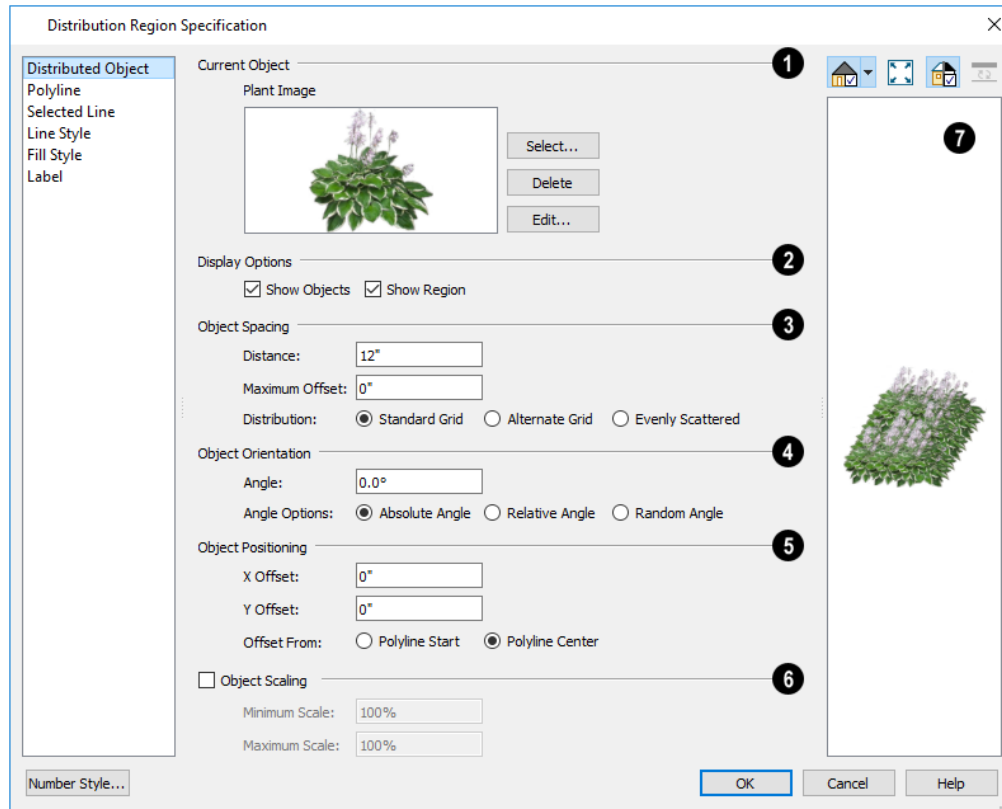

### 1 Current Object

Specify the **Current Object** assigned to the selected region. When an object is assigned, its name and a preview of a single instance of it display here.

- Click the **Select** button to choose an object from the library. See [Select Library Object Dialog on page 974](#).
- Click the **Delete** button to unassign the Current Object from the selected region.
- Click the **Edit** button to open the Current Object’s specification dialog. Changes made here affect all objects generated within the region. See [Specification Dialogs on page 21](#).

 You can replace the object assigned to a Distribution Region or Path by applying a new one directly from the library. See [Replace From Library on page 976](#).

### 2 Display Options

- Check **Show Objects** to display the distributed objects in plan view.
- Check **Show Region** to display the distribution region outline in plan view.

### 3 Object Spacing

Specify how the objects in the region are spaced.

- Specify the **Distance** between the objects in the region, as measured from their center points.
- Objects in the region can be randomly offset from their default positions if you wish. Specify their **Maximum Offset**, measured from their center points. Not available when Evenly Scattered is selected, below.
- Select **Standard Grid** to position the objects in rows and columns based on the standard X/Y grid in the program. This grid is affected by **Rotate Plan View**. See *Rotate Plan View on page 147*.
- Select **Alternate Grid** to position the objects in rows and columns based on the shape of the region.
- Select **Evenly Scattered** to distribute the objects evenly but not on a grid layout.

#### 4 Object Orientation

Specify how or if the objects in the region are rotated. These settings do not affect the region itself or its edges.

- Specify the **Angle** that the distributed objects should be placed at.
- Select **Absolute Angle** to rotate the objects relative to an imaginary horizontal line drawn in the positive X direction from the origin. See *3D Drafting on page 13*.
- Select **Relative Angle** to rotate the objects relative to the angle of the region's first edge or, if that edge is curved, to the angle of its chord. The first edge is typically located at the top of the region when it is first created; however, this can change as the region is edited.
- Select **Random Angle** to rotate the objects in the region at a variety of random angles.

#### 5 Object Positioning

Specify the positioning of the distributed objects relative to a point of origin within the region.

- Specify the **X Offset**, the horizontal distance in plan view from the region's specified point of origin.
- Specify the **Y Offset**, the vertical distance in plan view from the region's specified point of origin.
- Select **Offset From Polyline Start** to measure the offset from the region's start point. This start point is typically located at the top left of the region when it is first created; however, this can change as the region is edited.
- Select **Offset From Polyline Center** to measure the offset from the region's center point.

#### 6 Object Scaling

Check **Object Scaling** to specify a range of size variation of the objects in the region.

- Specify the **Minimum Scale**, which is the smallest resize of the objects allowed.
- Specify the **Maximum Scale**, which is the largest resize of the objects allowed.

#### 7 Preview

A preview of the region displays on the right side of the dialog box. If no object has been assigned to the selected region, Plan View will be the default preview type. See *Dialog Preview Panes on page 22*.

## DISTRIBUTED OBJECT PANEL - DISTRIBUTION PATH

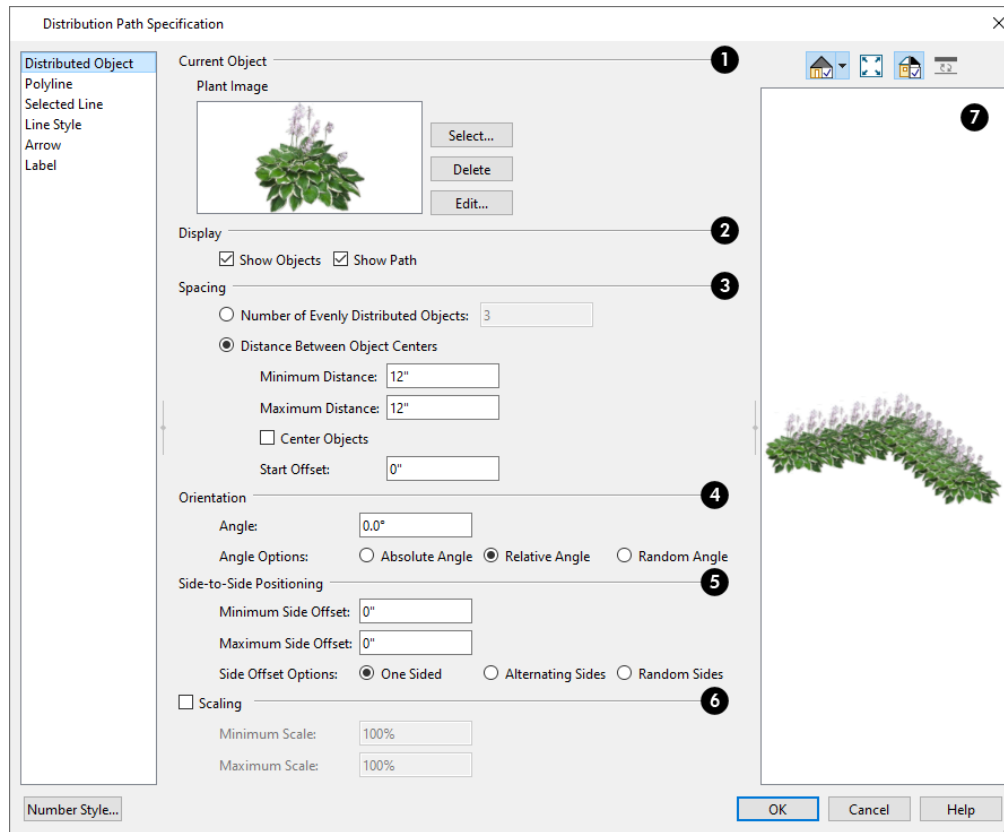

### 1 Current Object

Specify the object assigned to the selected path. When an object is assigned, its name and a preview of a single instance of it display here.

- Click the **Select** button to choose an object from the library. See [Select Library Object Dialog on page 974](#).
- Click the **Delete** button to unassign the Current Object from the selected path.
- Click the **Edit** button to open the Current Object's specification dialog. Changes made here affect all objects distributed along the path. See [Specification Dialogs on page 21](#).

### 2 Display Options

- Check **Show Objects** to display the distributed objects in plan view.
- Check **Show Path** to display the distribution path in plan view.

### 3 Object Spacing

Specify how the objects along the path are spaced.

- Select **Distance Between Object Centers**, then specify the distance between all object centers. If the path is resized, the total number of objects may change.
- Specify the **Minimum Distance** between object centers.

- Specify the **Maximum Distance** between object centers.
- When **Center Objects** is checked, the objects are centered along the length of the path. Uncheck this to position an object at the path's Start end and space additional objects along its length from there.
- Select **Number of Evenly Distributed Objects**, then specify the number of objects. If the path is resized, the spacing between objects may change.

#### 4 Object Orientation

Specify how or if the objects on the path are rotated.

- Specify the **Angle** that the distributed objects should be placed at.
- Select **Absolute Angle** to rotate the objects to the specified Angle as measured from an imaginary horizontal line drawn from the origin towards the right.
- Select **Relative Angle** to rotate each object relative to the edge of the polyline or spline that it is located on.
- Select **Random Angle** to rotate the objects in the region at a variety of random angles.

#### 5 Object Positioning

Specify the positioning of the distributed objects relative to the path itself.

- Specify the **Minimum Side Offset**, which is the smallest distance objects can be offset from the path.
- Specify the **Maximum Side Offset**, which is the largest distance objects can be offset from the path.
- The Side Offset Options control which side or sides of the path objects offset to.
- Select **One Sided** to offset objects on the left side of the path, as viewed from its starting point.
- Select **Alternate Sides** to position objects on alternating sides of the path, creating a stepped pattern.
- Select **Random Sides** to position objects on both sides in a random pattern.
- Specify the **Start Offset**, the distance that the first object on the path is offset from the path's starting point.

#### 6 Object Scaling

Check **Object Scaling** to specify a range of size variation of the objects along the path.

- Specify the **Minimum Scale**, which is the smallest resize of the objects allowed.
- Specify the **Maximum Scale**, which is the largest resize of the objects allowed.

#### 7 Preview

A preview of the path displays on the right side of the dialog box. If no object has been assigned to the selected path, Plan View will be the default preview type. See [Dialog Preview Panes on page 22](#).

### POLYLINE PANEL

The POLYLINE panel states the length of the region's **Perimeter** and its enclosed **Area**. See [Polyline Panel on page 317](#).

### SPLINE PANEL

The SPLINE panel has a single option and is only available when the selected object is spline-based. See [Splines on page 324](#).

**New Segment Angle** - Specify the angle between line segments that are used to draw the spline. Specifying a smaller angle makes the spline smoother. Specify a larger angle to draw the spline faster.

### **SELECTED LINE PANEL**

The SELECTED LINE panel is available when the selected edge of the region or path is a line as opposed to an arc. See [Selected Edge on page 212](#).

Moving the Start of a line segment moves the end of the previous connected line, if there is one. Similarly, moving the End of a line segment moves the start of the next connected line, if there is one.

The settings this panel are found in a variety of specification dialogs throughout the program. See [Line Panel on page 304](#).

### **SELECTED ARC PANEL**

The SELECTED ARC panel is available when the selected edge of the region or path is an arc as opposed to a line. See [Change Line/Arc on page 256](#).

The settings on this panel are found in a variety of specification dialogs throughout the program. See [Arc Panel on page 312](#).

### **LINE STYLE PANEL**

For information about the settings on this panel, see [Line Style Panel on page 305](#).

### **FILL STYLE PANEL**

The FILL STYLE panel is only available for a selected Distribution Path if it forms a closed shape.

For information about the settings on this panel, see [Fill Style Panel and Dialogs on page 193](#).

### **ARROW PANEL**

The ARROW panel is only available for Distribution Paths that do not form a closed shape. For information about the settings on this panel, see [Arrowheads on page 327](#).

### **LABEL PANEL**

Distribution Path labels display in floor plan and cross section/elevation views when the “Polylines 3D, Labels” layer is turned on and use the Text Style assigned to that layer.

For more information, see [Label Panel on page 700](#).

### **OBJECT INFORMATION PANEL**

The information entered on the OBJECT INFORMATION panel can be used in schedules and the materials list. For more information, see [Object Information Panel on page 1331](#).

### **SCHEDULE PANEL**

The settings on the SCHEDULE panel determine which schedule categories the selected object is included in. See [Schedule Panel on page 704](#).



# Materials

## Chapter 31

The objects used in Chief Architect have a variety of 3D properties. These objects - walls, windows, doors, cabinets, roof planes, lot perimeters, etc. - can have materials assigned to them so that they look realistic in 3D views. These materials can also be used to generate materials lists that can help with cost estimations.

Designing with objects that look correct in 3D and calculate properly in the Materials List requires that you use realistic material definitions and apply them appropriately to objects in your plan.

Chief Architect comes with many materials that are ready for use. From siding, roofing, flooring, masonry, tile, and paneling, to road surfaces, grass, water, and wood materials, Chief Architect has materials for every application, inside and out. If you cannot find a material that suits your needs, you can customize the materials provided or create your own.

Learning how to create, manage, apply, and edit materials saves time and adds that professional touch to your designs.



Redefining only the visual properties of a material may create unexpected results. For example, changing the image of a brick material to represent siding does not cause the material to be considered as siding during material calculations.

### TOPICS

<b>About Materials</b> .....	<b>1050</b>
<b>Material Defaults</b> .....	<b>1051</b>
<b>Material Painter Tools</b> .....	<b>1052</b>
<b>Materials Panel</b> .....	<b>1055</b>
<b>Select Material/Library Object Dialog</b> .....	<b>1056</b>
<b>Editing Materials</b> .....	<b>1058</b>
<b>Creating Materials</b> .....	<b>1060</b>
<b>Mapping Patterns and Textures</b> .....	<b>1062</b>
<b>Materials and the Materials List</b> .....	<b>1063</b>
<b>Managing Plan Materials</b> .....	<b>1064</b>
<b>Define Material Dialog</b> .....	<b>1066</b>
<b>Pattern from Texture Dialog</b> .....	<b>1077</b>

---

## About Materials

The materials that are assigned to objects in Chief Architect perform two important roles:

- They determine what the surfaces of objects look like in 3D views.
- They influence how objects are calculated in the Materials List. See [Materials Lists on page 1303](#).

Materials are stored in the Library Browser and can be applied to objects in either of two ways:

- Using the **Material Painter** . See [Material Painter Tools on page 1052](#).
- In an object's specification dialog. See [Materials Panel on page 1055](#).

### PATTERNS AND TEXTURES

In Chief Architect, materials have two attributes that determine what they look like in 3D views: Textures and Patterns.

- Textures are created using special image files that tile seamlessly when applied to surfaces and are visible in ray trace views and most Rendering Techniques. See [In Rendered Views on page 1099](#).
- Patterns are composed of CAD lines and are seen in Technical Illustration, Watercolor, Hand Drawn Lines, and Vector Views. Pattern lines are also represented when **Hand Drawn Lines on Top** is used in most other Rendering Techniques, as well. Select **3D> Toggle Patterns**  to toggle the display of patterns on or off in these views in the current plan. See [Rendering Techniques on page 1150](#).
- Materials also have a solid Material Color, which is the pattern field color and is also used if a material has no texture.

Often, the texture and pattern for a given material are both set up to represent the characteristics of the material in the real world and have similar sizing and angles. When customizing such a material, check **Keep Pattern/Texture in Sync** before making changes to maintain this consistency. See [Define Material Dialog on page 1066](#).

### MATERIAL MAPS

Material maps are specially produced image files that can add realism to a material's appearance in rendered and CPU Ray Trace views by making it appear contoured instead of flat, or rough instead of smooth or glossy.

Materials seen in the Standard, Physically Based, Clay, Duotone, and Watercolor Rendering Techniques may be affected by these material maps:

- Bump maps add the appearance of height differences to a material - for example, on bricks, stone, or textiles. In a bump map, dark areas of the image correspond to low points in the bump map, and light areas correspond to high points.
- Normal maps assign three dimensional data to the material on a surface, allowing lighting effects to be created - for example, along mortar or grout lines. In normal maps, multiple colors are used to indicate surface direction.
- Ambient Occlusion maps indicate which parts of a texture receive more ambient light and which parts receive less. In occlusion maps, light areas receive more ambient light while dark areas receive less.
- Roughness maps define areas of varying roughness or glossiness that affect how light reflects off those areas. Roughness maps are grayscale where white is very rough, black very smooth.
- Metal maps define areas within a single texture that are metallic. Metal maps are grayscale images in which black is not metallic but every other shade is.

You can choose to ignore any or all of these maps in Clay renderings as well as override material roughness in the Rendering Technique Options dialog. See [Clay Panel on page 1158](#).

All of these map types can be assigned to a material in the Define Material dialog. See [Texture Panel on page 1069](#) and [Properties Panel on page 1072](#).

## MATERIALS LIST CALCULATION METHODS

Every material can be assigned a Calculation method which defines how the material is calculated in the Materials List: for example, by piece, area, or volume. See [Materials and the Materials List on page 1063](#).

---

## Material Defaults

 Most objects in the program have defaults dialogs which allow you to set up a variety of attributes, including materials, before the objects are created. These defaults dialogs are accessed by selecting **Edit> Default Settings**. See [Preferences and Default Settings on page 76](#).

The Material Defaults dialog serves two purposes. It allows you to:

- Set the default materials for objects that do not have a defaults dialog: for example, fireplaces and furnishings from the library.
- Set the initial materials that can then populate a variety of defaults dialogs. Door, Window, and Cabinet Defaults are examples of defaults dialogs that can draw their material assignments from the Material Defaults dialog.

Material defaults are dynamic, which means that if you change a particular default material, all objects that are set to use that default will automatically update to use the new material. See [Dynamic Defaults on page 79](#).

Because material defaults are dynamic, you can use the Material Defaults dialog to apply a material to multiple objects that share similar components. For example:

- The “Room Moldings” Material Default applies to the base, crown, and chair rail moldings that can be assigned to rooms, as well as to interior door and window casing. If you change this Material Default, all of these objects in the plan can be affected.
- The “Cabinet”, “Cabinet Door/Drawer”, “Countertop”, and “Hardware” Material Defaults can be used in your Cabinet Defaults dialogs to ensure that all cabinets use the same materials. See [Dynamic Cabinet Defaults on page 618](#).

## MATERIAL DEFAULTS DIALOG

Select **Edit> Default Settings**  from the menu, select “Materials”, and click the **Edit** button to open the Material Defaults dialog.

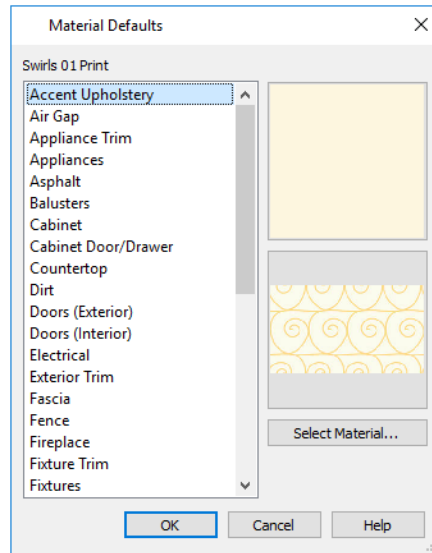

- Select a material category from the scrollable list. Select multiple line items using the Shift or Ctrl key. See *Shift and Ctrl Select on page 214*.
- Click the **Select Material** button or either material preview box to open the Select Material dialog. See *Select Material/Library Object Dialog on page 1056*.

## Material Painter Tools

 In a 3D view, select **3D> Material Painter** to access the **Material Painter Tools**, which are used to apply materials to object surfaces. The Material Painter tools are available in all Rendering Techniques except Glass House views. See *Glass House on page 1152*.

 If you use the Material Painter to change a room's floor or ceiling finish material, it will add that material to the room's Floor or Ceiling Finish Definition. Changes to a Deck room's planking or framing will affect its floor structure definition. See *Floor and Ceiling Platform Definitions on page 429*.



### MATERIAL PAINTER

 The **Material Painter** tool allows you to apply a selected material to other objects in 3D views. It can be activated in several ways:





- Select **3D> Material Painter> Material Painter** .
- Select a material in the Library Browser while a 3D view is active.
- The Material Painter also becomes active when the Material Eyedropper is used.

The **Material Painter**  is similar to the other Painter tools but has some additional considerations. See *Painter Tools on page 278*.

### To use the Material Painter tool

1. In a 3D view, select **3D> Material Painter> Material Painter** .
2. Choose a material from the Select Material dialog. See [Select Material/Library Object Dialog on page 1056](#).
  - Check **Use Default Material** at the bottom left of the LIBRARY MATERIALS panel or select “Use Default” from the top of the list on the PLAN MATERIALS panel to apply the default material to any object that has a defaults dialog. See [Material Defaults on page 1051](#).
3. If you click the **Copy Selected Material**  button, a copy of the selected material is created and the Define Material dialog will open, allowing you to customize that copy. See [Copy Selected Material on page 1054](#).
4. Select one of the **Material Painter Scoping Modes** from the Edit Toolbar. See [Material Painter Scoping Modes on page 1053](#), below.



5. If you selected a solid color material, choose whether to use the **Blend Colors with Materials**  option and click the edit button to turn this feature on or off. See [Blend Colors With Materials on page 1054](#), below.
  - The mouse pointer displays a paint roller icon  when **Blend Colors With Textures** is active.
  - The mouse pointer displays a spray can icon  when the **Material Painter** is active and **Blend Colors With Textures** is not.
6. Note that the name of the material being painted displays on the left side of the Status Bar at the bottom of the program window. See [The Status Bar on page 24](#).
  - Move your pointer over a surface in the 3D view. The Status Bar now states both the material being painted and the current material on the target surface.
7. Click on a surface to apply the selected material to that surface. The material is applied to surfaces in the model based on the active Material Painter Scoping Mode.
8. If either the **Component**  or **Object Mode**  is active, you can continue to click on surfaces to apply the selected material. When you are finished, select a different tool.

### MATERIAL EYEDROPPER

 The **Material Eyedropper** tool allows you to load the material assigned to an existing object into the Material Painter and apply that material to other objects and is similar to other Eyedropper tools. See [Eyedropper Tools on page 277](#).

### MATERIAL PAINTER SCOPING MODES

There are five Material Painter Scoping Modes, each specifying how broadly or narrowly the selected material will be applied to surfaces in your plan. They are similar to other Painter Scoping Modes in the program, but rather than modify instances of an object type, the Material Painter Scoping Modes replace instances of a material based on the selected scope. See [Painter Scoping Modes on page 278](#).

These Painter Scoping Modes are also available when the **Adjust Material Definition**  tool is used, allowing you to control how extensively a change to a material is applied throughout the current plan. See [Adjust Material Definition on page 1058](#).

 **Material Painter Component Mode** is the default mode and applies the selected material to a single component on the target object. For most object types, using this tool is the same as opening an object's specification dialog and changing the material of one of its components on the MATERIALS panel. See [Materials Panel on page 1055](#).

 **Material Painter Object Mode** replaces all instances of a material on the target object.

 **Material Painter Room Mode** replaces all instances of a material in the room where the target object is located.

 **Material Painter Floor Mode** replaces all instances of a material on the floor where the target object is located.

 **Material Painter Plan Mode** replaces all instances of a material in the entire plan.

## BLEND COLORS WITH MATERIALS

 The **Blend Colors With Materials** option allows you to apply a solid color to a surface displaying a texture or pattern and blend the two.

**Blend Colors With Materials**  works in all five Material Painter Scoping Modes. See [Blending Materials on page 1061](#).

## COPY SELECTED MATERIAL



 The **Copy Selected Material** tool creates a copy of the selected material, gives you an opportunity to customize it as needed, and then lets you apply the new material to surfaces in the model. This option is helpful if you need slightly different versions of the same material - for example, to orient wood planks or tile in different directions.

When you click the **Copy Selected Material**  button, the Define Material dialog will open, allowing you to customize the new material. When you click OK, the customized material is loaded into the Material Painter. See [Define Material Dialog on page 1066](#).



Once you apply the material to one or more surfaces in the model, it will be listed in the Plan Materials dialog. See [Managing Plan Materials on page 1064](#).

## MATERIAL PAINTER AND WALLS

Painting walls is an obvious use for the **Material Painter** ; however, it is important to note that the Material Painter Scoping Modes affect walls and rooms somewhat differently than they do other objects: particularly if a wall defines multiple rooms on the side that is being painted.

**Component**  and **Object Modes**  only paint the section of the wall that defines the room located where you click to apply a new material. Sections of the same wall that define other rooms are unaffected.

**Room Mode**  applies the material to all walls and solid railings that define the room where you click provided that they have the same original surface material as the one being painted. Any other objects in the room with that original material are also affected, but railings are not unless they are specified as Solid.

**Floor**  and **Plan Modes**  apply the material to all walls, all railings, and any other objects with the same original surface material as the one being painted: either on the current floor, or throughout the plan.

Note: Wall materials applied using the Material Painter tool are not calculated in the Materials List. See [In the Materials List on page 365](#).

# Materials Panel

The specification dialogs for most objects include a MATERIALS panel. Select an object or a group of similar objects and click the **Open Object** edit button to open the specification dialog for that selection.

On the MATERIALS panel, you can specify material assignments for the components that make up that object. When a new material is assigned, the appearance of the preview image on the right side of the dialog updates.

If the selected object is using a material that is missing its texture, a Caution ⚠ symbol will display next to the Materials panel name in the list on the left side of the object’s specification dialog. See *Linked and Referenced Files on page 51*.

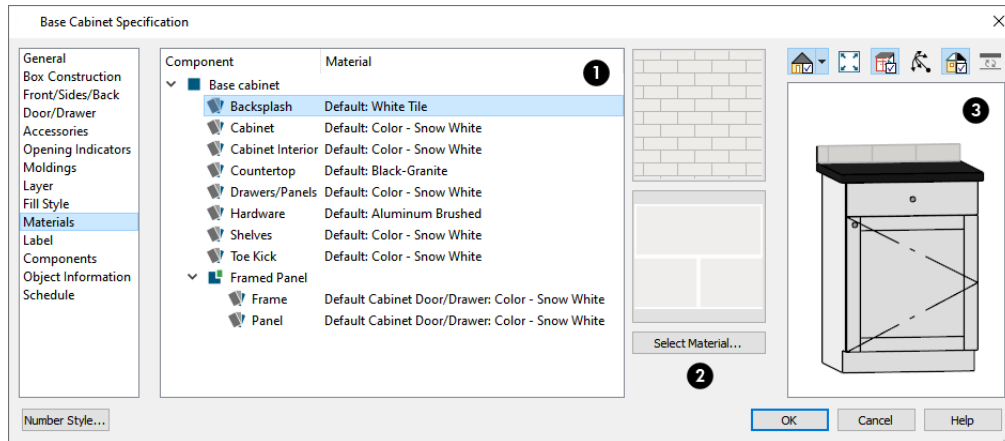

## 1 Object Components

The table on the left side of the panel lists the components of the selected object that can be assigned unique materials, along with the names of those materials and whether or not the default materials are used. Some objects may have only one component while more complex objects may have many. As changes are made to the selected object, components may be added to or removed from this table.

- Click on a Component in the table to select it. Multiple line items can be added to the selection set by holding down the Shift or Ctrl key. See *Shift and Ctrl Select on page 214*.
- The selected component’s Material is stated in the list, to the right of the component name. If the component is using the default material, the name will be preceded by the word “Default:”. If it is using a Material Default, it will be preceded by the word “Default” followed by the name of an object type. See *Material Defaults on page 1051*.
- If the selected component belongs to a symbol object from the library, you can click on it a second time to rename it. See *Native Objects vs Symbols on page 971*.

Note: If the selected object is a wall or a room modified using the Material Painter, a component’s Material may be described as “No Change”. See *Material Painter and Walls on page 1054*.

## 2 Material Preview

The two boxes to the right of the table display previews of the color, pattern, and texture of the material assigned to the selected component. If “No Texture” displays in the preview window, the material has no texture assigned to it; if a Caution ⚠ symbol and the words, “Texture Missing” display, the texture file could not be found on the system.

There are several ways to open the Select Material dialog and choose a different material for one or more selected line items:

- Double-click on a line item in the table.
- Select one or more line items and click the **Select Material** button.
- Select one or more line items and click on either of the preview boxes.

See *Select Material/Library Object Dialog on page 1056*.

### **3** Preview

A preview of the selected object displays on the right side of the panel. To view material textures, select **Standard** as the View Type; to view material patterns, select **Vector View**. See *Dialog Preview Panes on page 22*.

---

## Select Material/Library Object Dialog

The Select Material dialog allows you to select a material to apply to one or more objects and is opened by clicking the **Select Material** button on the MATERIALS panel of most specification dialogs or by using the **Material Painter** . See *Materials Panel on page 1055* and *Material Painter Tools on page 1052*.

The similar Select Library Object dialog allows you to select an item from the library to either apply or insert into a currently selected object. See *Placing Library Objects on page 972*.

The Select Library Object dialog has a single panel; however, depending on how it is accessed, the Select Material dialog will have either two or three panels:

- The *Library Materials Panel on page 1056* allows you to select materials from the Library Browser.
- The *Plan Materials Panel on page 1058* lets you select materials from the Plan Materials dialog.
- The *Material Defaults Panel on page 1058* lets you associate an object component with a Material Defaults category rather than a specific material and is only available when the component of a library symbol is selected on the MATERIALS panel of the object's specification dialog.

### LIBRARY MATERIALS PANEL

The LIBRARY MATERIALS panel is a modal version of the Library Browser that lists only materials. See *The Library Browser on page 946*.

Most of the settings on this panel are also found in the Select Library Object dialog. See *Select Library Object Dialog on page 974*.



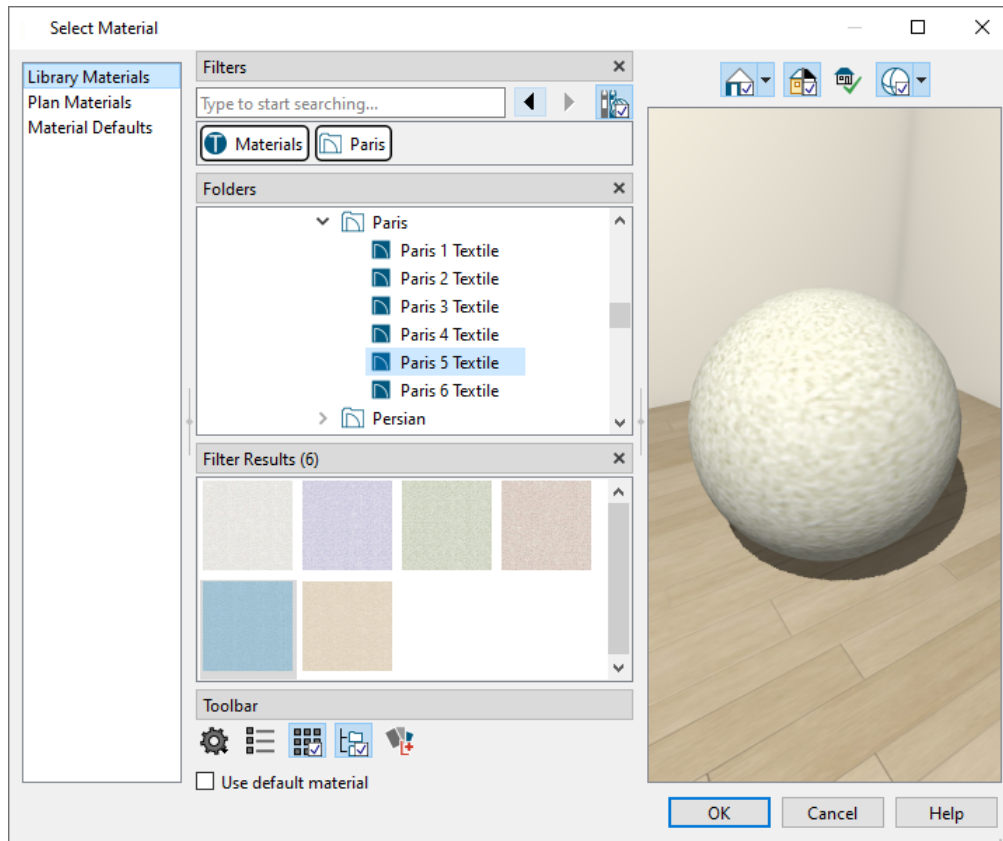



The LIBRARY MATERIALS panel has most of the functionality that the Library Browser has, including the search, search filtering options, and preview options.



- To locate a material, you can search, apply a Library Filter or Tag, or browse the Folders tree list. See *Searching and Filtering the Library on page 953*.
- Located below the tree list, check **Use default material** to apply the default material to the selected object component (s), if one exists. See *Material Defaults on page 1051*.
- A preview of the selected material displays on the right. See *Dialog Preview Panes on page 22*.
- To apply a material to an object, select it in the Filter Results panel and click OK.

A selection of buttons below the tree list allows you to control the appearance of the panes in this dialog. The Selection and Preview panes are always present when the dialog is first opened. See *The Library Browser on page 946*.

- For materials, select an object shape to display the material on in the preview on the far right: Cube, Sphere, Teapot, or Plane.

An additional button allows you to add new content to the User Catalog. The available option varies depending on the type of library item being assigned or inserted into another object.

- Click the **Add New Symbol**  button to import a 3D symbol into the User Catalog and select it. The symbol's category corresponds to the object component being edited, and cannot be changed. See *Importing 3D Symbols on page 998*.
- Click the **Add New Line Style**  button to open the Line Style Specification dialog. See *Line Style Specification Dialog on page 201*.
- Click the **Add New Fill Style**  button to open the Fill Style Specification dialog. See *Fill Style Panel and Dialogs on page 193*.

- Click the **Add New Backdrop**  button to open the Import Backdrop File dialog. See *3D Backdrops on page 1204*.
- Click the **Add New Material**  button to open the Define Material dialog and create a new material saved in the User Catalog. See *Define Material Dialog on page 1066*.

The OK button is only active when a library item is selected. If a library folder or catalog is selected, the OK button cannot be clicked.

## PLAN MATERIALS PANEL

The PLAN MATERIALS panel is similar to the Plan Materials dialog and lets you select from a list of materials already present in the plan as well as manage that list. See *Managing Plan Materials on page 1064*.

Select “Use Default” from the top of the list to apply the default material to the selected object, if applicable.

## MATERIAL DEFAULTS PANEL

The MATERIAL DEFAULTS panel will only be present if the Select Material dialog was accessed via an object specification dialog where a component of an inserted library symbol was selected.

Rather than apply a specific material to the selected component, you can dynamically associate it with a Material Default category. See *Material Defaults on page 1051*.

---

# Editing Materials

Much like objects, materials in Chief Architect can be edited so that they better suit your design needs. There are several ways to customize a material:

- Edit the original material and replace all instances of it in the current plan;
- Create and edit a copy of the original material and replace only some instances of the original in the current plan;
- Edit a material in the Library Browser and apply it in any plan as needed.



Editing the material applied to an object is not the same as applying a different material to that object. See *Material Painter Tools on page 1052*.

## ADJUST MATERIAL DEFINITION



The **Adjust Material Definition** tool lets you make changes to the materials seen in camera views.

**Adjust Material Definition** has five Painter Scoping Modes that allow you to control how extensively your changes to a given material are applied:





**Material Painter Component Mode** allows you to edit the material applied to a single component on a target object. If any other instances of the original material are present in the current plan, including on other components of the same object, you will be presented with the option of editing a copy of the original material on that component so those other instances can remain unchanged.



**Material Painter Object Mode** allows you to edit all instances of the material on a target object. If any other instances of the original material are present on other objects in the current plan, you will be presented with the option of editing a copy of the original material on the target object so those other instances can remain unchanged.

 **Material Painter Room Mode** allows you to edit all instances of the material located in the same room as the target object. If any other instances of the original material are present in other rooms in the current plan, you will be presented with the option of editing a copy of the original material so those other instances can remain unchanged.

 **Material Painter Floor Mode** allows you to edit all instances of the material located on the same floor level as the target object. If any other instances of the original material are present on other floors in the current plan, you will be presented with the option of editing a copy of the original material so those other instances can remain unchanged.

 **Material Painter Plan Mode** allows you to edit all instances of the material in the current plan. When Plan Mode is selected, the original material is modified and creating a copy of it is not an option.

### *To use the Adjust Material Definition tool*

1. Create a camera view in which a material that you would like to modify can be seen.
2. While the camera view is active, select **3D> Adjust Materials> Adjust Material Definition** .
3. Notice that the **Adjust Materials Painter Scoping Mode** buttons become available on the Edit Toolbar, and click on the Mode that suits your needs.
4. Select the material that you want to edit:
  - Move your mouse pointer over a surface and notice the Status Bar reports that material's name.
  - Click on a surface displaying the material you want to edit.
5. If the material is assigned to any objects outside the scope set by the selected Mode, the Create Copy of Material dialog will open.

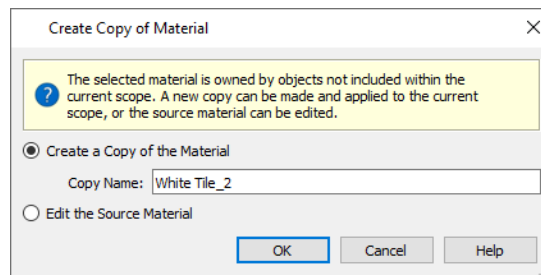

- Select **Create a Copy of the Material** to make a copy of the material and leave the original unchanged, then type a name for the new material in the **Copy Name** text field.
  - Select **Edit the Source Material** to modify the original material and apply your changes plan-wide.
6. The Define Material dialog opens next, allowing you to edit either the original material or a copy of it. See [Define Material Dialog on page 1066](#).
  7. When you click OK, your customized material will be applied in the current plan according to the selected Mode.

Changing a material definition using the **Adjust Material Definition** tool only affects objects in the current plan that are using that material. It does not affect any materials saved in the library or materials used in other plans. See [Adding Library Content on page 965](#).

## PLAN MATERIALS

 You can also edit, copy, and create new materials in the Plan Materials dialog. Select **3D> Materials> Plan Materials** to open this dialog for the current plan. You can add a newly defined material to the library from the Plan Materials dialog by selecting it and clicking the **Add to Library** button. See [Managing Plan Materials on page 1064](#).

## IN THE LIBRARY BROWSER

Materials saved in the User Catalog of the Library Browser are editable: right-click on one and select **Open Object**  from the contextual menu to open the Define Material dialog for that material. See [Editing Library Objects on page 970](#).

---

# Creating Materials

Chief Architect provides a wide variety of materials - including numerous name brand material catalogs - that are ready to download and use. If you cannot find a suitable material, you can edit an existing material or create a new one. See [Editing Materials on page 1058](#).

## TEXTURE FILE MANAGEMENT

Materials often have a texture and one or more material maps, which are image files that add realism to the material's appearance. In order to display a material's texture and material maps, Chief Architect needs to be able to locate the image files associated with them on your computer. See [Linked and Referenced Files on page 51](#).

If a texture or material map referenced by a newly created material is not located in either the Chief Architect Premier X15 Data folder or the installation folder for the program's library textures, a copy of the file will be made in Chief Architect Premier X15 Data\Textures\Material Data and the material will reference that copy. See [Chief Architect Premier Data on page 37](#).

## IN THE PLAN MATERIALS DIALOG

There are two ways to create a new material in the Plan Materials dialog. See [Managing Plan Materials on page 1064](#).

- Click the **New** button to create a new material for use in the current plan file.
- Select a material and click the **Copy** button to make a new material based on the original, which can then be edited and used in the current plan.

To make a plan material available for use in other plans, select it and click the **Add to Library** button. See [Adding Library Content on page 965](#).

## IN THE LIBRARY BROWSER

Materials can be created in the Library Browser, making them available for use in any plan. See [Adding Library Content on page 965](#).

In the directory pane of the Library Browser, right-click on an unlocked folder and select **New> Material**  from the contextual menu. See [Using the Contextual Menu on page 951](#).

The Define Material dialog opens, allowing you to specify the new material's attributes. See [Define Material Dialog on page 1066](#).

## USING PASTE IMAGE

A new material can be created by copying an image that will serve as its texture to the system clipboard, then navigating to a Chief Architect window and selecting **Edit> Paste> Paste**  from the menu. See [Cut, Copy, and Paste on page 168](#).

## FROM A SCREEN CAPTURE

You can use the **Screen Capture** tools to create a texture based on a screen capture from any application and use it to create a new material in the User Catalog in the library. See *Creating Screen Captures on page 1203*.

By default, materials created from a screen capture will be set to **Stretch to Fit**. If you would like the texture to tile instead, uncheck this box. See *Stretch to Fit on page 1063*.

## COPYING MATERIALS

 When the **Adjust Material Definition** tool is used with any scoping mode other than Plan Mode, the program will prompt you to choose whether to edit the original material or create a copy of it. See *Adjust Material Definition on page 1058*.

## BLENDING MATERIALS

 In 3D views, you can create a new material by blending a solid color such as a paint color with a textured and/or patterned material. Select **3D> Material Painter> Blend Colors With Materials** to toggle this feature on or off. See *Blend Colors With Materials on page 1054*.

The result is a new material that is saved in the current plan. It can be found in the Plan Materials dialog, edited as needed, and added to the library if desired. See *Managing Plan Materials on page 1064*.

Materials created using the **Blend Colors With Materials**  tool are given the name of the patterned/textured material with the extension "--PAINTED:" followed by the name of the solid color material.

Component	Material
▼ Base cabinet	
Backsplash	Default: White Tile
Cabinet	Rustic Hickory--PAINTED: Color - Chocolate

## CONVERT TEXTURES TO MATERIALS

 An entire folder of textures can be converted into a library of materials. Select **3D> Materials> Convert Textures to Materials** and then browse to a folder of textures on your computer. The converted library folder assumes the same file structure as the original folder.

Materials created using this tool do not refer to the original folder of texture files. Instead, they refer to files copied into the Data folder like individually-created materials do. See *Texture File Management on page 1060*, above.

## CREATE PLAN MATERIALS LIBRARY

 Select **3D> Materials> Create Plan Materials Library** to create a library of materials based on the materials used in the current plan. This is useful for converting material template plans, a common way to store material definitions in prior versions of Chief Architect, into a materials library. This command creates a new library in the Materials category using the same name as the plan. Adding materials to the library individually allows you to store the material within the existing directory structure.

## Mapping Patterns and Textures

Materials have two attributes that determine what they look like in 3D views: patterns and textures. See [About Materials on page 1050](#).

Both patterns and textures have points of origin, which determine where the pattern or texture begins on an X/Y axis. By default, this origin is 0,0; however, you can specify a different origin for each in the Define Material dialog. See [Define Material Dialog on page 1066](#).

You can also specify whether a material's pattern and texture origins are set globally or independently for each object. By default, this mapping is per object; check **Global Symbol Mapping** on either the TEXTURE or PATTERN panel of the Define Material dialog to map all instances of the material throughout the plan from the same origins.

If a material has any material maps assigned to it, they use the same Offset settings as the texture. See [Material Maps on page 1050](#).

If a material is set to map globally, it may not look right on some surfaces in 3D views. If this is the case and you do not wish to map the material independently on each object, you can create a copy of the material for each surface that requires modification and specify its texture's origin.



The fill styles of CAD objects are similar to material patterns and can also be mapped on an individual object basis. See [Fill Style Panel and Dialogs on page 193](#).

### DETERMINING THE ORIGIN

Before a new origin can be specified, the display of coordinates in the Status Bar should be enabled. See [The Status Bar on page 24](#).

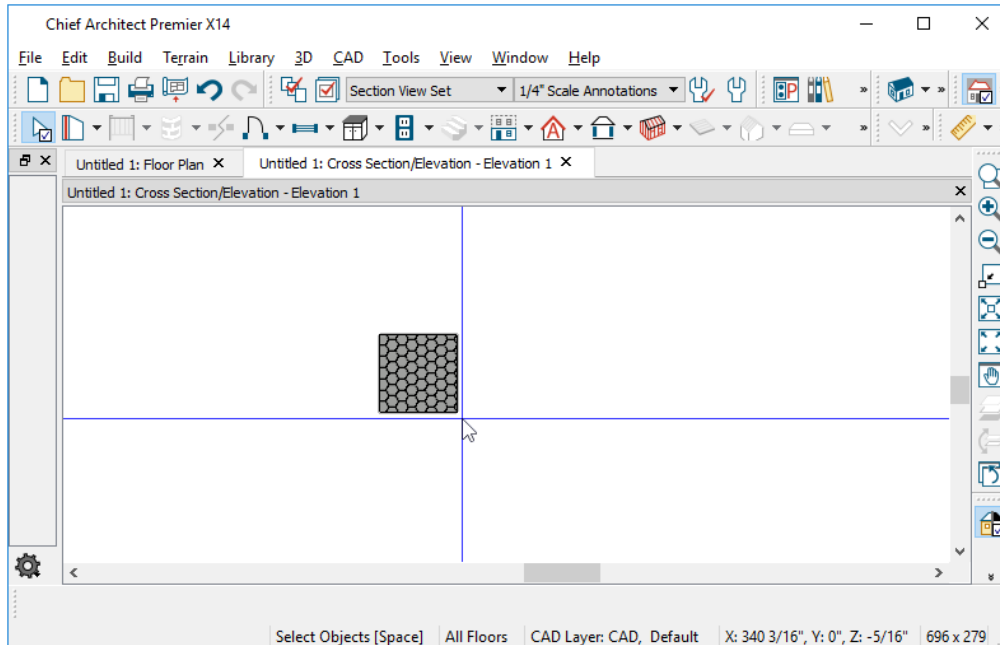

To determine origin coordinates on the horizontal plane, place your cursor over the origin location in floor plan view. When the pointer is in the position you want to establish as the material origin, take note of the coordinates that display in the Status Bar.

To determine origin coordinates on the vertical plane, place your cursor over the origin location in a cross section/elevation view.

Once you have taken note of the new origin coordinates, enter them as Horizontal and Vertical Offsets on either the PATTERN or TEXTURE panel of the Define Material dialog. See *Define Material Dialog on page 1066*.

A texture or pattern origin is a property of the material rather than of the object that the material is assigned to. When an object is moved, the pattern or texture maintains its absolute position and may not look right. It is a good idea to assign pattern or texture origins only after the position of the object has been finalized.

## STRETCH TO FIT

Some special textures, often used for artwork, do not tile. Instead, these textures resize to stretch across any surfaces that they are applied to. Materials that behave this way are specified as **Stretch to Fit** in the Define Material dialog. See *Define Material Dialog on page 1066*.

To display an artwork texture, first place a wall or desk frame in your plan. A selection of both are available in the library. See *Placing Library Objects on page 972*.

Next, simply apply a material specified as **Stretch to Fit** to the center portion of the frame. See *Material Painter Tools on page 1052*.

---

# Materials and the Materials List

When applied to structural components like slabs or wall, floor and ceiling, or roof layers, materials determine how or whether those components are calculated in the Materials List. Each material's Structure Type and its Calculation Method are specified in the Define Material dialog. See *Materials List Panel on page 1075*.

## MATERIAL STRUCTURE TYPES

The Material Structure Type controls how or whether certain structural features generate in the model.

- The Concrete type must be assigned to a wall type in order for a brick ledge to be cut into it. This type is also required to produce rebar, steel mesh, and pour number calculations in the Materials List. It is recommended for concrete walls, footings, monolithic slabs, and Slab Footings. See *Foundations on page 705* and *Brick Ledges on page 353*.
- The Masonry type must be assigned to the exterior layer of a wall type in order to generate a brick ledge in the wall below.
- The Other type is useful for other structural applications such as framing, sheathing, and siding.

## CALCULATION METHODS

A material's Calculation method controls how it is counted in the Materials List when it is applied to structural components like wall, ceiling, floor, ceiling, or roof layers; slabs; or to generic objects like Primitive objects.

For walls, structural assembly layers, and slabs, "Area", "Count" and "Linear" calculations are based on the area of the assembly or the top of the slab. If a material is calculated by "Count", its Depth is not used; however, the thickness of the layer or slab is noted in the Size column of the Materials List.

For Primitives as well as Soffits, "Area", "Count" and "Linear" calculations are made for all sides of the object. The Depth of materials calculated by "Count" is used, but thickness is otherwise not noted.

- "Area" calculates the total area of a material in structural layers, slabs, and Primitives in square feet (m).
- "Count" calculates a piece count based the material's Width, Height, and Depth.

- "Linear" calculates the total length of strips required to cover the area in feet (m).
- "Volume" calculates the total volume of a material in structural layers, slabs, and Primitives in cubic yards (m)
- "None" prevents the material from being calculated in the materials list at all.

 To prevent a structural layer from being counted in the materials list as well as from displaying in the 3D model, specify it as an Air Gap. See *Wall Type Definitions Dialog on page 387* and *Material Layers Definition Dialogs on page 1040*.

Once a Materials List has been created, the unit of measurement can be changed. See *Changing Count Units on page 1319*.

## REPRESENTING OVERLAP

Any material using the Count or Linear Calculation method can be set up to account for material overlap in the Define Material dialog. To do this:

- On the PATTERN panel, set up the material's pattern so that it accurately represents the size and shape of the exposed portion of an individual piece or strip.
- On the TEXTURE panel, set the Scale to represent the appearance of the exposed material in rendered 3D views.
- On the MATERIALS LIST panel, specify the full size of the actual material, including the overlapped portion.

If a material is set up to represent overlapping pieces, it is important that you not click the **Update from Pattern** button. See *Materials List Panel on page 1075*.

---

## Managing Plan Materials

 The Plan Materials dialog allows you to manage the materials used in the current plan. Select **3D> Materials> Plan Materials** to open this dialog. You can also access its settings in the Select Material dialog. See *Select Material/Library Object Dialog on page 1056*.

When a material is applied to an object in a plan, a copy of that material is created and saved with the plan. If you use the Define Materials dialog to modify that material, your changes affect it wherever it is found throughout that plan. All objects in that plan that use that material are affected, but objects placed in other plans are not.

 All materials that come with Chief Architect are stored in the Library Browser. You can create your own materials and save them there, as well. See *Creating Materials on page 1060*.



## PLAN MATERIALS DIALOG

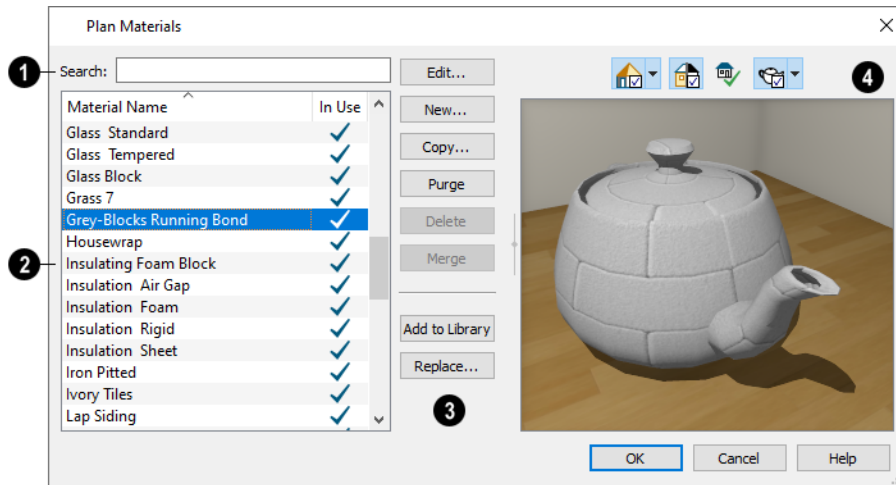

### 1 Search

Begin typing in the text field. As you type, the list below will be filtered to show only materials with names that contain your text.

### 2 Plan Materials

A sortable, scrollable list of the materials referenced by the current plan displays here. Click on the name of a material to select it. Select multiple materials by holding down the Shift or Ctrl key.

- If there is a check mark in the **In Use** column, the material is used by one or more objects in your plan or is defined as a default material for one or more objects in your plan.
- If the **In Use** column is empty, the material was used at one time but is no longer assigned to any objects or used as a default.

### 3 Management Options

The buttons on the right allow you to modify the selected material and manage the items in the list.

- Click **Edit** to open the Define Material dialog for the selected material. See *Define Material Dialog on page 1066*.
- Click **New** to open the Define Material dialog to create a new material.
- Click **Copy** to create a copy of the selected material and open the Define Material dialog where you can make changes to the copied material.
- Click **Purge** to remove all unused materials from the plan.
- Click **Delete** to remove the selected material from the plan. If the material is used in the model, you cannot delete it.
- Click the **Merge** button to merge multiple selected materials into one. The material that is listed first is retained and all other materials in the selection set are deleted. Any instances of the deleted materials in the plan are replaced by the first material. Only available when multiple materials are selected.
- Click **Add to Library** to add the selected material to the Library Browser, making it available for use in other plans. See *Adding Library Content on page 965*.

- Click the **Replace** button to replace the selected material with a new one from the library. Materials assigned to objects as well as those set in object defaults dialogs are affected. See [Select Library Object Dialog on page 974](#).

#### 4 Preview

A preview of the material applied to an object displays here. If multiple materials are selected at once, the first one in the list will display. Various options allow you to view different aspects of the material's attributes:

- Display the material in Physically Based, Standard rendering, Vector View, or in a CPU Ray Trace view.
- Zoom and orbit the object in the view.
- Toggle Color on or off.
- Click the **Restore Original View**  button to reset the material preview to its original perspective.
- Select an object shape: Cube, Sphere, Teapot, or Plane.

The Rendering Technique and object shape selections in this dialog's preview are shared with the Define Material dialog. Unlike other dialog previews, these are retained when you close the dialog. The object shape selection is also shared with the Library Browser. See [Dialog Preview Panes on page 22](#) and [The Library Browser on page 946](#).



 You can create a folder containing all of the current plan's Plan Materials in the Library Browser User Catalog. See [Create Plan Materials Library on page 1061](#).

---

## Define Material Dialog

The Define Material dialog allows you to adjust how materials look in 3D views as well as how they are calculated in the Materials List.

The Define Material dialog can be accessed in a number of ways:

- Use the **Adjust Material Definition**  tool. See [Adjust Material Definition on page 1058](#).
- Select a material from the Plan Materials dialog and click **Edit**, **New**, or **Copy**. See [Managing Plan Materials on page 1064](#).
- Right-click on a material in the User Catalog in the Library Browser and select **Open Object**  from the contextual menu. When multiple materials are selected, some settings will not be available. See [Using the Contextual Menu on page 951](#).
- You can also right-click on the User Catalog and select **New> Material**.

If you select a material from a Manufacturer Catalog, some options in the Define Material dialog may not be available and the panels may vary. See [Manufacturer Catalogs on page 961](#).

If you access the Define Material dialog through a menu or specification dialog, any changes you make will affect that material wherever it is found in the current plan. Other objects in that plan using that material will also be affected, but objects outside the current plan will not. You can click the **Add to Library** button at the bottom of the dialog to add the material to the User Catalog for future use in any plan. See [Adding Library Content on page 965](#).

The Rendering Technique and object shape selections in this dialog's preview are shared with the Plan Materials dialog and, unlike other dialog previews, are remembered during the current program session. See [Dialog Preview Panes on page 22](#).

The Define Material dialog has the following panels:

## PATTERN PANEL

Patterns are used to represent materials in Technical Illustration, Hand Drawn Lines, and Vector Views. See *Patterns and Textures on page 1050*.

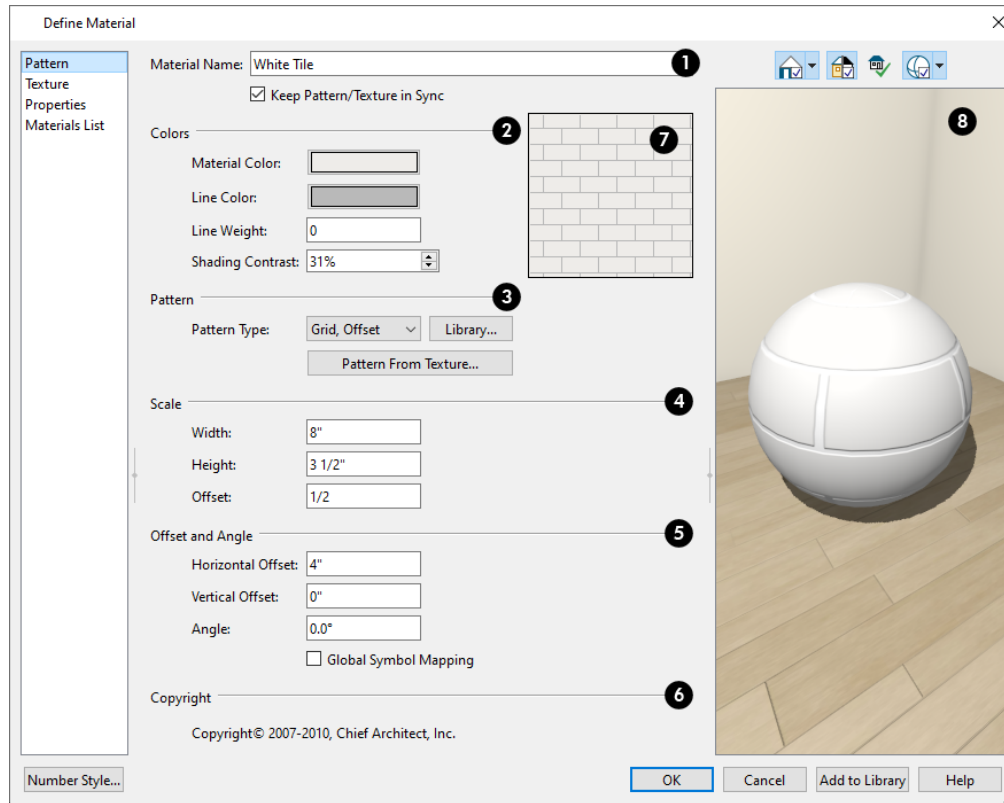

### 1 Material Name

The **Material Name** displays here. You can type a different name if you wish. Renaming the material does not create a new material: it redefines the existing material. See *Creating Materials on page 1060*.

- Check **Keep Pattern/Texture in Sync** to maintain consistent **Scale** and **Offset and Angle** settings for both the selected material's pattern and its texture if any of these settings are modified.

### 2 Colors

Specify the **Colors** used to represent the material's pattern in Vector Views. Click either color box to open the Select Color dialog and select a color. See *Color Chooser/Select Color Dialog on page 203*.

- The **Material Color** displays in Vector Views and is also used if a material has no texture specified. See *In Vector Views on page 1099*. This color also affects Transparent materials in rendered and CPU Ray Trace views: choose white for a fully transparent material or black for one that is completely opaque. See *Properties Panel on page 1072*.
- The pattern **Line Color** displays in Vector Views only.
- Specify the **Line Weight**, which is the thickness of the pattern lines.
- Specify the **Shading Contrast**, which is the amount of contrast between surfaces at different angles to each other in Vector Views. See *Vector View on page 1150*.

The following shows a curved wall with three different Shading Contrasts (created in a separate graphics program). Notice how the lowest contrast at the top appears almost flat.

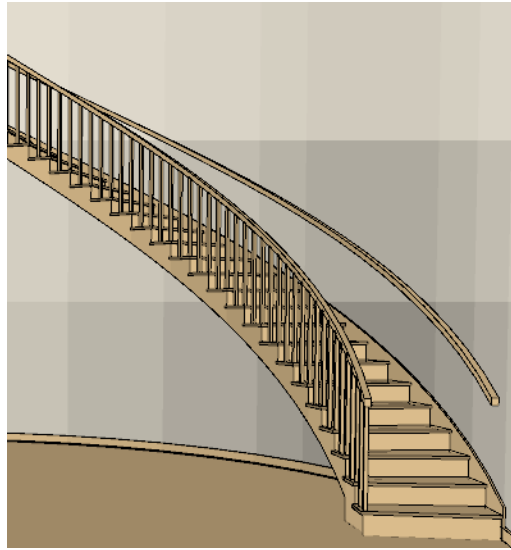

### 3 Pattern

When “No Pattern” is selected as the Pattern Type, the Scale, Offset and Angle settings are disabled.

- Select a **Pattern Type** from the drop-down list. Select “Library” or click the **Library** button to select a pattern from the library. When a pattern is selected from the library, its name will display in the list. See [Select Library Object Dialog on page 974](#).
- Click the **Pattern from Texture** button to create a custom pattern based on the material’s texture. When a pattern is created using this option, the name of the material’s texture file will display in the Type drop-down list. Only available if the material has a texture assigned to it. See [Pattern from Texture Dialog on page 1077](#).

 You can also create custom patterns using the CAD drawing tools. See [Custom Patterns on page 196](#).

### 4 Scale

- Specify the **Width** of the selected pattern. For Concrete and Sand materials, instead adjust the overall pattern **Spacing**. Not available if Pattern from Texture has been used.
- Specify the selected pattern’s **Height**. Only available for Brick, Tile, Shingles, and U’s patterns.
- Specify the pattern’s **Scale**. If the pattern appears black in the square preview pane, this value should be increased. Only available for imported patterns and some patterns from the library.

### 5 Offset and Angle

- Specify the **Horizontal** and **Vertical Offsets**, if needed, so the pattern displays correctly on surfaces. See [Mapping Patterns and Textures on page 1062](#).
- Specify the **Angle**, measured counterclockwise, in degrees.

- Check **Global Symbol Mapping** to map the pattern and texture using the same origin on all objects. When unchecked, the origin is defined individually for each object.

## 6 Copyright

If the selected pattern has a **Copyright**, information about it displays here.

## 7 Pattern Preview

A preview of the material's pattern displays in the square pane. It updates as you change the pattern's specifications.

## 8 Preview

A preview of the material applied to an object displays here and updates as changes are made to the material definition. Various options allow you to view different aspects of the material's attributes:

- Display the material in Physically Based or Standard rendering, Vector View, or in a CPU Ray Trace view.
- Zoom and orbit the object in the view.
- Toggle **Color** on or off.
- Click the **Restore Original View**  button to reset the material preview to its original perspective.
- Select an object shape: Cube, Sphere, Teapot, or Plane.

The Rendering Technique and object shape selections in this dialog's preview are shared with the Plan Materials dialog. Unlike other dialog previews, these are retained when you close the dialog. The object shape selection is also shared with the Library Browser. See [Managing Plan Materials on page 1064](#).

## TEXTURE PANEL

In most Rendering Techniques as well as in CPU Ray Trace views, materials are represented using textures and other material maps. See [Material Maps on page 1050](#) and [Rendering Techniques on page 1150](#).

Transparency information may be contained on the alpha channel of a texture; if so, it is used in rendered and CPU Ray Trace views.

If a texture or material map referenced by a newly created material is not located in either the Chief Architect Premier X15 Data folder or the installation folder for the program's library textures, a copy of the file will be made in Chief Architect Premier X15 Data\Textures\Material Data and the material will reference that copy. See [Chief Architect Premier Data on page 37](#).

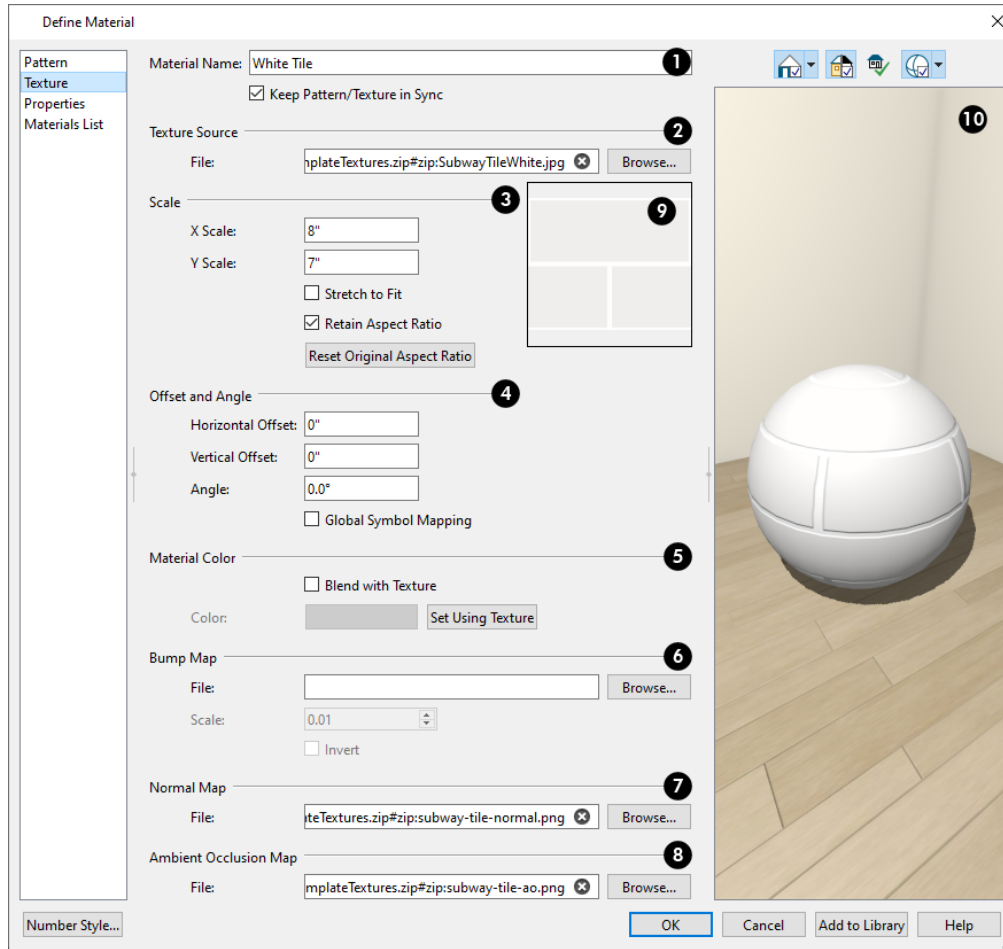

### 1 Material Name

The Material Name displays here and can be changed if you wish. Renaming the material does not create a new material: it redefines the existing material.

- Check **Keep Pattern/Texture in Sync** to maintain consistent **Scale** and **Offset and Angle** settings for both the selected material’s pattern and its texture if any of these settings are modified.

### 2 Texture Source

Displays the path and file name of the selected texture.

- Click the **Browse** button to browse to a texture file saved on your computer. Supported file formats are **.jpg**, **.bmp**, **.png**, **.gif**, and **.tif**. See *Creating Materials on page 1060*.
- You can also type or paste the full path name of a texture in the text field. To remove the file, click the **Remove** **✕** button.
- Textures saved in **.zip** files can also be used. See *To use an image saved in a .zip file on page 1072*, below.

### 3 Scale

These settings affect both the selected material’s texture and any material maps assigned to it. See *Material Maps on page 1050*.

- Adjust the **X Scale** and **Y Scale**, or height and width, of the selected texture.

If a rendered surface is larger than the area described by the Scale, the surface has “tiles” of the texture image. If it is smaller, only a portion of the texture is shown.

- Check **Stretch to Fit** to stretch the texture image to cover each surface it is applied to. Stretch to Fit is typically used for artwork or photography in a frame.

Note: Changing the scale or selecting Stretch to Fit can cause textures to appear distorted if applied to a surface with a different aspect ratio than the original texture image.

- Check **Retain Aspect Ratio** to maintain the ratio between the texture image’s height and width and prevent distortion when either its X or Y Scale value is adjusted.

#### 4 Offset and Angle

These settings affect the material's texture as well as any material maps assigned to it. See [Mapping Patterns and Textures on page 1062](#).

- Specify the **X** and **Y Positions** of the texture’s origin, **if needed**, to adjust its layout on surfaces.
- Specify the **Angle** of the texture on the surfaces of objects, in degrees.
- Check **Global Symbol Mapping** to map the texture and pattern using the same origin on all objects. When unchecked, the origin is defined individually for each object.

#### 5 Material Color

Material Color can also be set on the PATTERN panel. See [Pattern Panel on page 1067](#).

- Check **Blend with Texture** to apply the Material Color over the material’s texture.

When a new material is created using the **Blend Colors With Materials**  tool, the resulting material has this box checked. See [Blend Colors With Materials on page 1054](#).

- Click the **Color** button to specify the Material Color.
- Click the **Set Material Color Using Texture** button to use the predominant color of the material’s texture. See [Patterns and Textures on page 1050](#).

#### 6 Bump Map

A **Bump Map** is an image file that makes a material look rough or textured. See [Material Maps on page 1050](#).

- The full path name of the selected bump map image **File** displays here. To remove the file, click the **Remove**  button.
- Click the **Browse** button to browse to a bump map image file saved on your computer. Bump maps saved in **.zip** files can also be used. See [To use an image saved in a .zip file on page 1072](#), below.
- The **Scale** setting allows you to specify how drastic the effect of the bump map is. The default value is 0.01, but larger or smaller values may give better results, depending on the bump map. Values can be typed to 0.001 accuracy.
- Check **Invert** to correspond light areas in the image with low points in the bump map and dark areas with high points. When unchecked, the opposite occurs.

#### 7 Normal Map

A **Normal Map** is an image file that makes a material appear to have depth.

- The full path name of the selected normal map image **File** displays here. To remove the file, click the **Remove**  button.
- Click the **Browse** button to browse to a normal map image file saved on your computer. Normal maps saved in **.zip** files can also be used. See *To use an image saved in a .zip file on page 1072*, below.

## **8** Ambient Occlusion Map

An **Ambient Occlusion Map** is an image file that affects how much ambient light each part of the material receives.

- The full path name of the selected ambient occlusion map image **File** displays here. To remove the file, click the **Remove**  button.
- Click the **Browse** button to browse to a file saved on your computer. Ambient occlusion maps saved in **.zip** files can also be used. See *To use an image saved in a .zip file on page 1072*, below.

## **9** Texture Preview

A preview of the material's texture displays in the square pane. It updates as you change the material definition.

## **10** Preview

A preview of the material applied to an object displays here and updates as changes are made to the material definition. Various options allow you to view different aspects of the material's attributes:

- Display the material in Physically Based or Standard rendering, Vector View, or in a CPU Ray Trace view.
- Zoom and orbit the object in the view.
- Toggle Color on or off.
- Click the **Restore Original View**  button to reset the material preview to its original perspective.
- Select an object shape: Cube, Sphere, Teapot, or Plane.

### *To use an image saved in a .zip file*

1. Type or copy the full path name of the **.zip** file in the text field.
2. Directly after the path name, type #zip:, followed immediately by the name of the bump map file including its file extension.

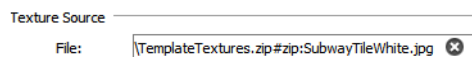

## **PROPERTIES PANEL**

The **PROPERTIES** panel controls how the material appears in most rendered 3D views and in CPU Ray Trace views.

A material's rendered appearance is also affected by the Render settings in the Preferences dialog and the lights that have been placed in the model. See *Light Types on page 1137*.

For special lighting effects on an object, use at least one point or spot light.

If a Roughness or Metal Map file referenced by a newly created material is not located in either the Chief Architect Premier X15 Data folder or the installation folder for the program's library textures, a copy of the file will be made in Chief Architect Premier X15 Data\Textures\Material Data and the material will reference that copy. See *Chief Architect Premier Data on page 37*.



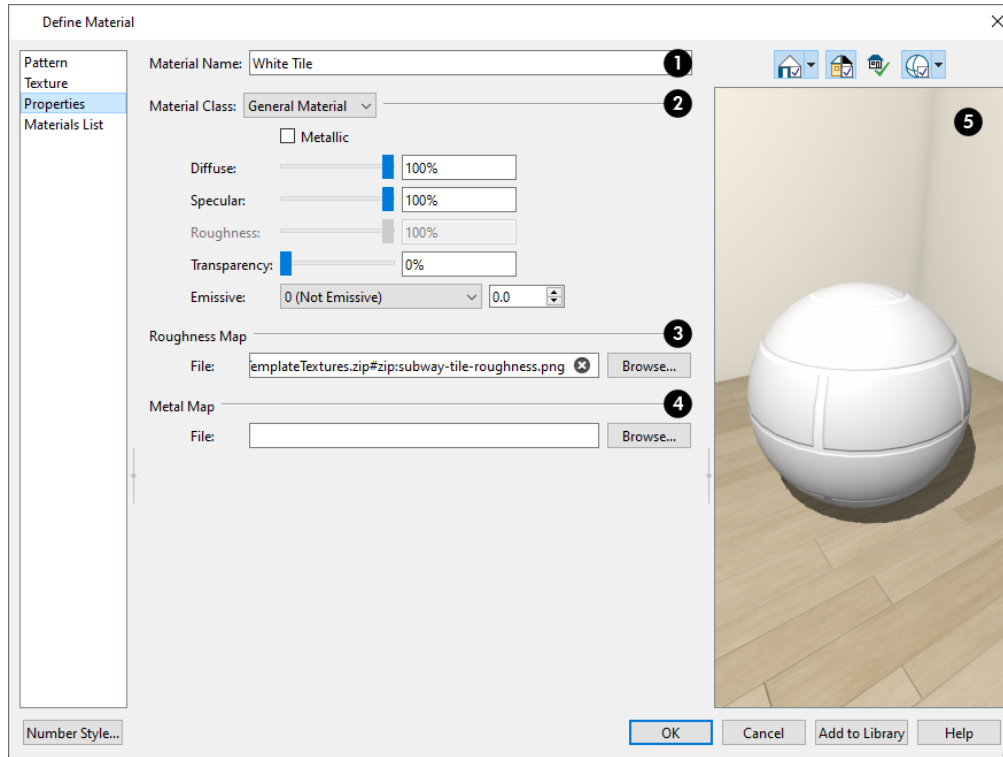

## 1 Material Name

The **Material Name** displays here. You can type a different name if you wish. Renaming the material does not create a new material: it redefines the existing material.

## 2 Material Class

Select a Material Class from the drop-down list. Each has its own set of characteristics that affects its appearance in rendered and CPU Ray Trace views.

- **General Material** - Most materials fall into this category, which gives you control over a number of properties.
- **Matte** materials are also limited for a specific purpose. They are not specular, emissive, transparent, or reflective.
- **Mirror** materials are limited to a specific purpose. They are not diffusive, specular, rough, emissive, or transparent and do not use the material's texture when ray traced. When Reflections are enabled in a camera view, flat surfaces with a Mirror material display reflections. See [Reflections on page 1133](#).
- **Plastic** materials are limited in that they are not specular, emissive, transparent, or reflective.
- **Polished** materials represent surfaces with multiple layers, such as those that are glazed, varnished, or buffed. They are not emissive, transparent, or reflective, but are specular and have additional control over Roughness.
- **Predefined Metal** use scientifically measured physical properties of a selection of real-world metals. Predefined metals do not use the material's pattern or texture when ray traced, and their editing options are limited to Roughness and metal type.
- **Shiny Metal** is also limited for a specific purpose and are not diffuse, emissive, or transparent. When ray traced, they do not use the material's texture.

- **Translucent** - Similar to General Materials, Translucent materials are not emissive or reflective. Contrary to the name, Translucent materials are not transparent, either. They do have a Translucency setting, but it only applies to light coming directly from a light fixture and only takes effect in CPU Ray Trace views. Ambient light or reflected light cannot pass through Translucent materials so objects cannot be seen through Translucent materials at all - even in CPU Ray Trace views.
- **Transparent** is another material class limited for a specific purpose. Transparent materials are not diffusive, specular, rough, or emissive, but do allow you to specify how light bends when passing through the material.

Adjust the settings associated with the selected Material Class using the slide bar or by entering a value in the text box to specify the appearance of the material in 3D views in which textures are used.

- Check **Metallic** to give the material the appearance of metal in Physically Based renderings and in CPU Ray Trace views. Only available for General materials.
- **Diffuse** controls the degree to which the material's main color contributes to its appearance. Not available for Metal, Mirror, or Transparent materials, or when Metallic is checked.
- **Specular** controls how bright the material appears when illuminated by a point or spot light. It simulates the reflection of light off a surface. Not available for Reflective, Predefined Metal, Mirror, or Transparent materials.
- **Roughness** controls how shiny a material is when illuminated by a point or spot light. A material with a low Roughness value has a bright, round spot of light when rendered with a point or spot light shining on it. Not available for Polished, Mirror, or Transparent materials, or when a Roughness Map is specified, below.
- **Transparency** controls how opaque or transparent a material is. Most materials are opaque while some materials, such as glass, are partially transparent. In some situations, materials with transparency can slow down rendering speed. Only available for Transparent and General materials, this option is not available when Metallic is checked and does not affect the appearance of Transparent materials in ray traced views.

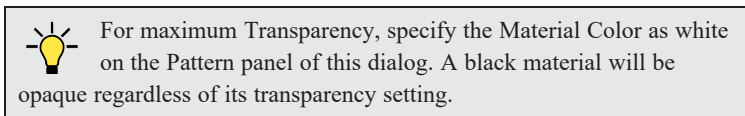

- **Emissive** controls how bright a material appears independent of the lighting in the scene. It can be used to simulate surfaces that are glowing with their own light, such as the glass on a light fixture. Choose a level of brightness from the drop-down list and customize it using the spin control arrows or text field. Only available for General materials, this option is not available when Metallic is checked.
- **Reflection** controls how reflective a material appears in CPU Ray Trace views. See [CPU Ray Trace Views on page 1168](#). Click the **Color** button to specify the color of light reflecting off a Mirror or Shiny Metal material. For most material classes, Reflection is best seen at glancing angles to the surface. For reflectivity from all angles, use a Mirror material. Not available for General, Matte, Plastic, Polished, or Predefined Metal materials.
- **Translucency** controls the degree to which light coming directly from a light fixture shines through the material. Only available for Translucent materials, this setting only affect CPU Ray Trace views.
- Select a **Metal** from the drop-down list. Only available for Predefined Metals.
- **Brushed Metal** creates a brushed appearance for Predefined Metal materials.

Polished and Brushed Predefined Metals can have different amounts of roughness running in different directions on a given surface. These surfaces look different depending on the viewing angle.

- **U Roughness** produces reflective highlights oriented horizontally. Only available for Polished materials and Brushed Predefined Metal materials.

- **V Roughness** produces reflective highlights oriented vertically. Only available for Polished materials and Brushed Predefined Metal materials.
- **Index of Refraction** controls how much light bends when it passes through the material in GPU and CPU Ray Trace views. A value of 1 is the lowest possible value and produces no light bending. Only available for Transparent materials.

### 3 Roughness Map

A Roughness Map defines areas of varying roughness and glossiness. Not available for Mirror or Transparent materials. See [Material Maps on page 1050](#).

- The full path name of the selected roughness map image **File** displays here. To remove the file, click the **Remove**  button.
- Click the **Browse** button to select a file saved on your computer. Roughness maps saved in **.zip** files can be used. See [To use an image saved in a .zip file on page 1072](#).

### 4 Metal Map

A Metal Map defines areas within a texture that are metallic. Only available for General materials.

- The full path name of the selected metal map image **File** displays here. To remove the file, click the **Remove**  button.
- Click the **Browse** button to select a file saved on your computer. Metal maps saved in **.zip** files can be used. See [To use an image saved in a .zip file on page 1072](#).

### 5 Preview

A preview of the material applied to an object displays here and updates as changes are made to the material definition. Various options allow you to view different aspects of the material's attributes:

- Display the material in Physically Based rendering, Standard rendering, Vector View, or in a CPU Ray Trace view.
- Zoom and orbit the object in the view.
- Toggle **Color** on or off.
- Click the **Restore Original View**  button to reset the material preview to its original perspective.
- Select an object shape: Cube, Sphere, Teapot, or Plane.
- Select a **Ray Trace Configuration** from the drop-down list to use in the preview. Only available when CPU Ray Trace is the selected preview view type.

## MATERIALS LIST PANEL

The settings on the MATERIALS LIST panel control how the selected material is counted in the Materials List. See [Materials and the Materials List on page 1063](#).

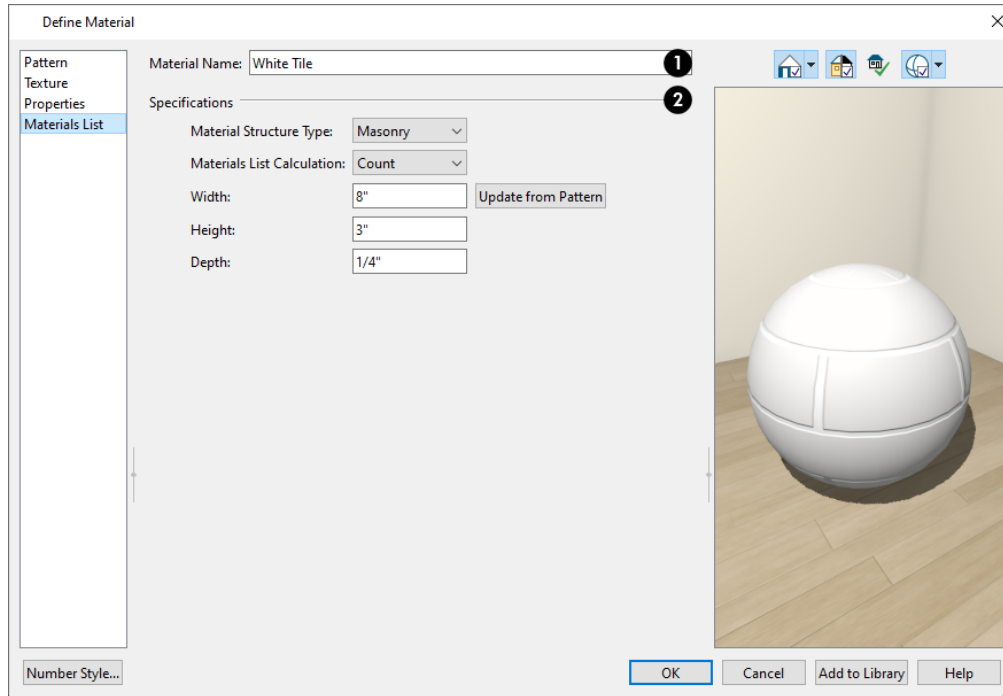

### 1 Material Name

The **Material Name** displays here. You can type a different name if you wish. Renaming the material does not create a new material: it redefines the existing material.

### 2 Specifications

- Select a **Material Structure Type** from the drop-down list. The selected Type defines how - or whether - the material is calculated in the Materials List. See *Material Structure Types on page 1063*.
- Select a **Materials List Calculation** method. When “Framing” is the selected Structure Type, the only available Calculation Method will be “Framing”. See *Calculation Methods on page 1063*.
- The settings that are available below depend on which Calculation method is selected.
- Specify the material’s **Width**. This value is available for Count and Linear Calculation methods.
- Specify the material’s **Height**. Only available for the Count Calculation method.
- Click the **Update from Pattern** button to make the Width and Height values here match those set on the PATTERN panel. Only available when Count or Linear is selected as the Calculation method.
- Specify the material’s **Depth**. Only available for the Count Calculation method, this value is only used for Materials List calculations when the material is applied to a Soffit or Primitive object. This value may also be used if the Material Painter is used to create a floor or ceiling finish. See *Floor and Ceiling Finishes and the Material Painter on page 429*.

## MANUFACTURER PANEL

If the selected material is from a Manufacturer library catalog, the Define Material dialog will have a fifth panel: the MANUFACTURER panel, which lists contact information. See *Manufacturer Catalogs on page 961*.

## Pattern from Texture Dialog

Click the Pattern from Texture button in the Define Material dialog to create a custom pattern based on the material's texture. This dialog also opens if you click on the name of a custom pattern in the **Type** drop-down list. See [Pattern Panel on page 1067](#).

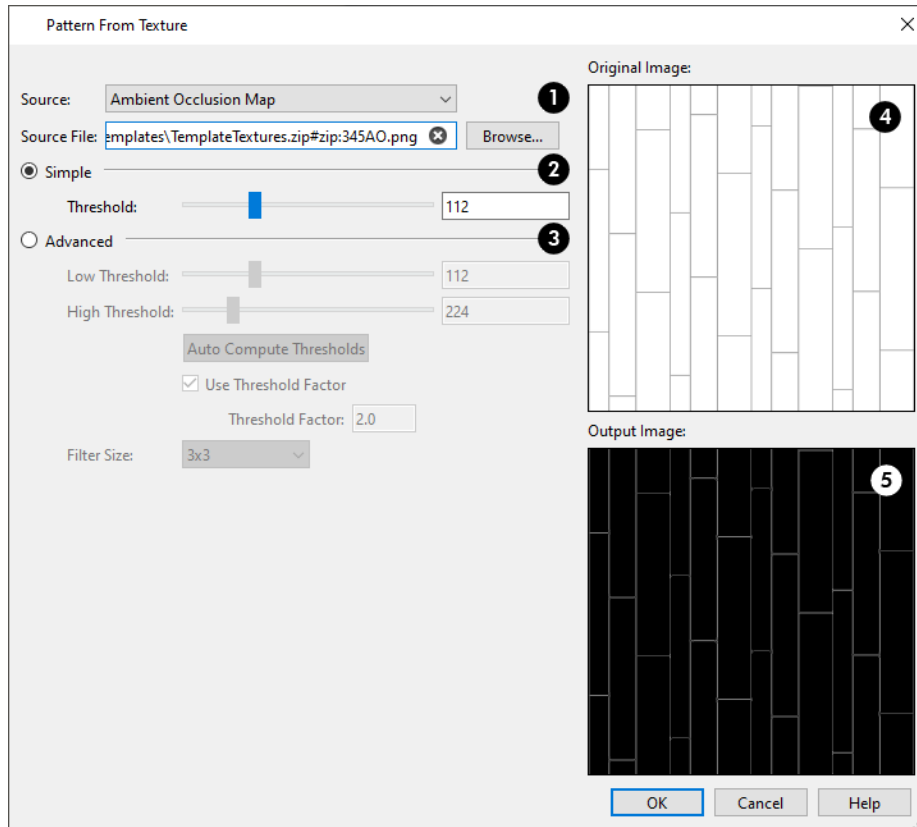

### 1 Source

- Select a material map assigned to the selected material from the **Source** drop-down list. See [Material Maps on page 1050](#).
- The full pathname of the selected **Source File** is reported and can be changed in the text field. Click the **Browse** button to choose a different file if you wish. See [Opening and Importing Files on page 44](#).

### 2 Simple

The **Simple** option is selected by default. Use the **Threshold** slider bar or text field to control the strength of edge lines in the pattern output. A low value produces many pattern lines while a high value produces few.

### 3 Advanced

Select **Advanced** to enable additional controls for generating edge lines in the pattern.

- Use the **Low** and **High Threshold** slider bars and/or text fields to control the strength of edge lines in the pattern output. Low values produce many pattern lines while high values produces few.

- Click the **Auto Compute Thresholds** button to reset the Threshold values automatically generated for the current material texture.
- When **Use Threshold Factor** is checked, the High Threshold setting will be greater than the Low Threshold setting by the Threshold Factor value and the two values will be tied together. Uncheck this box to edit the two values separately.
- Specify the **Threshold Factor**, between 1 and 10. Not available when Use Threshold Value is unchecked.
- Select a **Filter Size** from the drop-down list. A smaller size generates fewer lines while a larger size generates more.

#### **4 Original Image**

A preview of the material texture displays in the **Original Image** pane for reference.

#### **5 Output Image**

A preview of the pattern displays in the **Output Image** pane. As changes are made to the settings on the left, this preview will update.

# 3D Views

# Chapter 32

Little preparation is needed to create a 3D view of a model: simply click a button to create an overview or click and drag to create a camera or cross section/elevation view.

To improve the quality of the rendering and create a custom look, you can adjust lighting and edit the materials used in the plan. See *3D Rendering on page 1131*.

Many objects can be placed and edited in 3D views, and any camera view or overview can be saved or even used to record a walkthrough. See *Pictures, Images, and Walkthroughs on page 1184*.

## TOPICS

<b>Types of 3D Views</b> .....	<b>1080</b>
<b>3D View Defaults and Preferences</b> .....	<b>1080</b>
<b>Camera Defaults Dialogs</b> .....	<b>1081</b>
<b>3D View Defaults Dialog</b> .....	<b>1083</b>
<b>3D View Tools</b> .....	<b>1084</b>
<b>Creating Camera Views</b> .....	<b>1086</b>
<b>Creating Overviews</b> .....	<b>1087</b>
<b>Cross Section/Elevation Views</b> .....	<b>1089</b>
<b>Clipped Section Views</b> .....	<b>1091</b>
<b>Detailing Cross Section/Elevation Views</b> .....	<b>1094</b>
<b>Displaying 3D Views</b> .....	<b>1097</b>
<b>Navigating in Camera Views</b> .....	<b>1100</b>
<b>Editing 3D Views</b> .....	<b>1105</b>
<b>Cross Section Slider</b> .....	<b>1108</b>
<b>Working in 3D</b> .....	<b>1109</b>
<b>Virtual Reality</b> .....	<b>1110</b>
<b>Saving and Printing 3D Views</b> .....	<b>1115</b>
<b>Camera Specification Dialogs</b> .....	<b>1116</b>
<b>Cross Section/Elevation Specification Dialogs</b> .....	<b>1124</b>

---

## Types of 3D Views

There are three categories of 3D views in Chief Architect: camera views, overviews and cross section/elevation views. Each of these view types can be generated using a variety of Rendering Techniques. See [Rendering Techniques on page 1150](#).

Every 3D view is also either orthographic or perspective in nature. Cross section/elevation views are always orthographic while camera views are always perspective. You can choose to generate overviews as either orthographic or perspective.

### PERSPECTIVE AND ORTHOGRAPHIC VIEWS

Perspective views have a focal, or vanishing, point. Surface edges and lines that would be parallel in real life appear to converge towards that focal point, and objects closer to the camera appear larger while objects farther from the camera appear smaller.

Orthographic views do not have a focal or vanishing point. Parallel surface edges and pattern lines appear parallel in these views and objects appear to be the same size regardless of their distance from the camera.

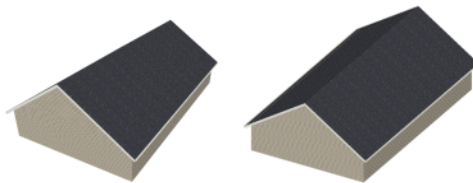

Perspective views display 3D objects much the way that they appear to the eye in real life, so they are ideal for presentation views. By default, perspective views are created using the Standard Rendering Technique.

Orthographic views, on the other hand, are useful for technical drawings. By default, orthographic views are created using the Vector View technique.

### RENDERED AND VECTOR VIEWS

3D views can be generated using a variety of different Rendering Techniques. See [Rendering Techniques on page 1150](#).

Most rendered views represent materials using textures. Surface edge lines are generally not drawn and lighting is often modeled, creating results that range from a photorealistic appearance to artistic painting styles. Standard rendered views can also be Ray Traced for additional realism. See [CPU Ray Tracing on page 1167](#).

Vector Views are non-photorealistic views in which objects are drawn using surface edge lines, or vectors. Limited lighting and shadows can be calculated and materials are represented using pattern lines and solid colors. Vector Views are ideal for layout drawings and high resolution printing. See [Vector View on page 1150](#).

---

## 3D View Defaults and Preferences

There are a number of defaults and preference settings that allow you to control the initial characteristics of 3D views.



Camera positioning, field of view and related initial settings for camera views are specified in the Camera Defaults dialogs. See [Camera Defaults Dialogs on page 1081](#).



The settings in the **3D View Defaults** dialog control a variety of functions that affect views created by all 3D View tools. See [3D View Defaults Dialog on page 1083](#).





The default characteristics of the **Generic Sun** light source can be specified in the Generic Sun Defaults dialog. See [Adjust Sunlight Dialog on page 1148](#).



As in plan view, the display of objects in 3D views can be controlled by layer. You can specify which layer set is initially used when a view is created by each of the 3D View tools. See [Layer Set Defaults on page 183](#).



3D views can be generated using any of the **Rendering Techniques**. See [Rendering Techniques on page 1150](#).



The initial settings for each Rendering Technique can be set in the Rendering Techniques Defaults dialog. See [Rendering Technique Options on page 1153](#).



The RENDER panel of the Preferences dialog has settings that affect 3D views. See [Render Panel on page 124](#).

## Camera Defaults Dialogs



There are several defaults dialogs for cameras, which can be accessed by selecting or by double-clicking either the **Orthographic or Perspective View Tools** parent button. Select an item in the submenu to open the defaults dialog associated with your selection.

The defaults dialog for Camera Tools other than Overviews can be accessed by double-clicking the associated toolbar button.

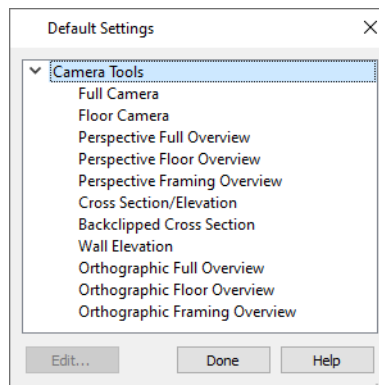

The various Camera Defaults in the list can be multiple-selected and then edited as a group by holding down the Shift or Control keys. Depending on the selection, not all settings may be available. See [Shift and Ctrl Select on page 214](#).

The settings in the Camera Defaults dialogs affect how each type of camera captures, clips, and renders views; how they display in plan view; how they are positioned; and how they move.

Once a camera is created, its attributes can be customized. See [Editing 3D Views on page 1105](#).

### FULL CAMERA DEFAULTS

Specify the initial attributes of cameras created using the **Full Camera**  tool. See [Camera Views on page 1084](#).

The settings in this dialog are the same as those the Full Camera Specification dialog. See [Camera Specification Dialogs on page 1116](#).

Note: The Reflections setting in the Full Camera Defaults is used by walkthroughs created using the Walkthrough Path tool. See [Recording a Walkthrough on page 1215](#).

## FLOOR CAMERA DEFAULTS

Specify the initial attributes of cameras created using the legacy **Floor Camera**  tool. This tool is not in the menus or default toolbars but can be added to the toolbars and/or assigned a hotkey if you wish. See *Toolbars and Hotkeys on page 128*.

The settings in this dialog are the same as those in the Floor Camera Specification dialog.

## PERSPECTIVE FULL OVERVIEW DEFAULTS

Specify the initial attributes of cameras created using the **Perspective Full Overview**  tool. See *Full Overview on page 1087*.

The settings in this dialog are the same as those in the Perspective Full Overview Specification dialog.

## PERSPECTIVE FLOOR OVERVIEW DEFAULTS

Specify the initial attributes of cameras created using the **Perspective Floor Overview**  tool. See *Floor Overview on page 1087*.

The settings in this dialog are the same as those in the Perspective Floor Overview Specification dialog.

## PERSPECTIVE FRAMING OVERVIEW DEFAULTS

Specify the initial attributes of cameras created using the **Perspective Framing Overview**  tool. See *Overviews on page 1085*.

The panels in this dialog are the same as their respective panels in the Orthographic Framing Overview Specification dialog.

## CROSS SECTION/ELEVATION DEFAULTS

Specify the initial attributes of cameras created using the **Cross Section/Elevation**  tool. See *Cross Section/Elevation Views on page 1085*.

The settings in this dialog are also found in the **Cross Section/Elevation Specification** dialog. See *Cross Section/Elevation Specification Dialogs on page 1124*.

## BACK CLIPPED CROSS SECTION DEFAULTS

Specify the initial attributes of cameras created using the **Back Clipped Cross Section**  tool. See *Cross Section/Elevation Views on page 1085*.

The panels in this dialog are the same as their respective panels in the Cross Section/Elevation Specification dialog. See *Cross Section/Elevation Specification Dialogs on page 1124*.

## WALL ELEVATION DEFAULTS

Specify the initial attributes of cameras created using the **Wall Elevation**  tool. See *Cross Section/Elevation Views on page 1085*.

The panels in this dialog are the same as their respective panels in the Wall Elevation Specification dialog. See *Cross Section/Elevation Specification Dialogs on page 1124*.

## ORTHOGRAPHIC FULL OVERVIEW DEFAULTS

Specify the initial attributes of cameras created using the **Orthographic Floor Overview**  tool. See [Full Overview on page 1087](#).

The panels in this dialog are the same as their respective panels in the Orthographic Full Overview Specification dialog.

## ORTHOGRAPHIC FLOOR OVERVIEW DEFAULTS

Specify the initial attributes of cameras created using the **Orthographic Full Overview**  tool. See [Overviews on page 1085](#).

The panels in this dialog are the same as their respective panels in the Orthographic Full Overview Specification dialog.

## ORTHOGRAPHIC FRAMING OVERVIEW DEFAULTS

Specify the initial attributes of cameras created using the **Orthographic Framing Overview**  tool. See [Overviews on page 1085](#).

The panels in this dialog are the same as their respective panels in the Orthographic Framing Overview Specification dialog.

---

# 3D View Defaults Dialog

 Select **3D > 3D View Defaults** or **Edit > Default Settings**  to open the 3D View Defaults dialog.

The settings in this dialog control a variety of functions that affect views created by all 3D View tools.

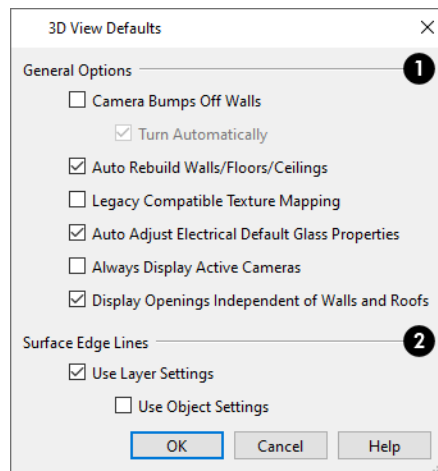

### **1** General Options

These settings affect all 3D views.

- Check **Camera Bumps Off Walls** to prevent cameras from moving freely through walls. When this setting is on, you can "walk" up a staircase by moving the camera using the Move Camera Tools.

- When **Turn Automatically** is checked, cameras automatically change direction when they approach a wall, door opening, or staircase. This should be unchecked when using a 3D mouse or gamepad. See *3Dconnexion® 3D Mice on page 1101* and *Move Camera Tools on page 1103*.
- Check **Auto Rebuild Walls/Floors/Ceilings** to automatically rebuild floors and ceilings before a 3D view or elevation is displayed. When this is unchecked and the structure is not up-to-date, the Rebuild Walls, Floors, Ceilings  icon displays near your mouse pointer. See *Rebuilding Walls, Floors and Ceilings on page 735*.
- Check **Legacy Compatible Texture Mapping** to use global texture mapping settings rather than texture mapping fixed to individual objects.



- When **Auto Adjust Electrical Default Glass Properties** is checked, the program automatically adjusts the behavior of electrical fixture glass in Standard rendered and CPU Ray Trace views in response to interior and exterior lighting conditions. When this box is unchecked, these adjustments are not made.
- Check **Always Display Active Cameras** to turn on the display of active camera symbols, even when the “Cameras” layer is turned off. When unchecked, active camera symbols obey the layer setting.
- When **Display Openings Independent of Walls and Roofs** is checked, doors, windows, and skylights display in 3D views when their containing wall or roof plane does not. Uncheck this to prevent these objects from displaying in 3D when their parent objects do not.

## 2 Surface Edge Lines

Specify how Surface Edge Lines display for all objects in Vector View renderings. Surface edge line color in Technical Illustration renderings are also affected by these settings. See *Rendering Techniques on page 1150*.

- Check **Use Layer Settings** to display surface edge lines for objects using the display settings specified by layer in the Layer Display Options dialog. If this option is not checked, all edge lines are drawn black and solid with a line weight of 0. See *Layer Attributes on page 177*.
- When **Use Object Settings** is checked, all objects that have non-default settings specified on the LINE STYLE panel of their specification dialog display using those settings, overriding the layer settings in the Layer Display Options dialog. Only available when Use Layer Settings is checked. See *Line Style Panel on page 305*.

---

## 3D View Tools



Select **3D> Create Orthographic View** to display the Orthographic View Tools or **3D> Create Perspective View** to display the Perspective View Tools.

There are four types of 3D Views:

### CAMERA VIEWS

Camera views are Perspective views. They are not scaled and cannot be annotated but are ideal for creating presentation views.



The **Full Camera** tool creates multi-floor views of the 3D model. It can be used to create interior and exterior perspectives, and is good for displaying cathedral ceilings, roofs, lofts, stairwell openings, and other variation in floor and ceiling levels.



The **Floor Camera** tool creates perspective views of the current floor only. Nothing above the ceiling surface is generated, and neither is anything below the floor. This legacy tool is not in the menus or default toolbars but can be added to the toolbars and/or assigned a hotkey if you wish. See *Toolbars and Hotkeys on page 128*.

## OVERVIEWS

An overview can be either orthographic in nature or perspective, depending on the tool used to create it. See *Creating Overviews on page 1087*.



The **Orthographic** and **Perspective Full Overview** tools create views of the entire model including all floors, ceilings, and the roof.



The **Orthographic** and **Perspective Floor Overview** tools create views of the current floor with the ceiling removed and all floors beneath it visible.



The **Orthographic** and **Perspective Framing Overview** tools create views of the framing in the model. Framing must be built in order for it to display in a framing overview. See *Framing Overview on page 1088*.



The **Isometric Overview** tools create specially oriented and scaled overviews that are common in engineering drawings. These tools are only available when an Orthographic Overview is active. See *Isometric Overviews on page 1088*.

## CROSS SECTION/ELEVATION VIEWS

Cross Section/Elevation views are similar to the traditional, scaled orthographic views often used in drafting. They are scaled and can be fully annotated. See *Cross Section/Elevation Views on page 1089*.



A **Cross Section/Elevation** view displays all floors of the model. If the view is created outside the structure looking toward it, the result is an exterior elevation. If the view is created inside the structure, or passes through any of the structure, a cross section is created.



The **Back Clipped Cross Section** tool includes only the objects between the starting point and stopping point of the cross section line.



The **Wall Elevation** tool creates an elevation of a wall on a single floor and in a single room. The **Wall Elevation** tool cannot be used to create exterior views.

Select **3D> Create Auto Elevations**  to access tools that create, save, and name elevation views as soon as the tool is selected. These tools can also be added to your toolbars. See *Auto Elevation Tools on page 1091*.



The **Front Elevation** tool creates an exterior elevation of the front of the model (on screen, the bottom).



The **Back Elevation** tool creates an exterior elevation of the back of the model (on screen, the top).



The **Left Elevation** tool creates an exterior elevation of the left side of the model.



The **Right Elevation** tool creates an exterior elevation of the right side of the model.



The **All Elevations** tool creates an exterior elevation of the front, back, left, and right sides of the model.



The **Create Room Elevation Views** edit tool creates an interior elevation view of each wall defining a selected room. This tool is found on the Edit Toolbar for a selected room rather than in the 3D menu. See *Editing Rooms on page 419*.

 An individual wall's framing members can also be displayed and edited in a Wall Detail view. See *In Wall Detail Views on page 880*.

## CPU RAY TRACE VIEWS

 CPU Ray Trace views are a special type of high-quality 3D view in which the paths individual photons are calculated so that realistic lighting effects can be modeled. They cannot be created directly from plan view. Instead, you must first create a Standard or Physically Based rendered view of the desired scene and then select **3D > CPU Ray Trace**. See *CPU Ray Tracing on page 1167*.

---

## Creating Camera Views

All Camera views are created using the same method.

### To create a camera view

1. In plan view, select the desired camera tool. The mouse pointer displays the camera  icon.
2. Click and drag a line to define the view direction.

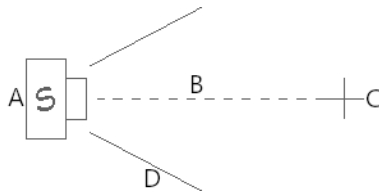

- A. Camera Position (click)
- B. Line of Sight (drag)
- C. Focal Point (release)
- D. Field of View

- The camera's position is where you click to begin the line.
  - The line that you drag defines the direction the camera is pointed.
  - The end of the line is the focal point of the view, the point the camera rotates around.
  - The Field of View is 55° by default.
3. When you release the mouse button, a view generates in a new window.
  4. Return to the plan view. A camera symbol now displays in plan view. See *Working in Multiple Views on page 150*.

In order to create a camera view, you must click and drag at least as far as your current **Snap Distance**. See *Snap Properties Panel on page 119*.

A new camera can also be created by copying and pasting an existing camera symbol selected in plan view. See *Copying and Pasting Objects on page 167*.

 You can also create a camera view based on a single frame of a Walkthrough Path. See *Walkthrough Previews on page 1212*.

## CAMERA HEIGHT

By default, Cameras are created at a height of 60" (1500 mm). Where this height is measured from depends on the location of the camera:

- If the camera is inside a room, it is measured from that room's subfloor.
- If the camera is outside a room but inside the Terrain Perimeter, it is measured from the terrain at the location of the camera.
- If the camera is located in neither a room nor within the Terrain Perimeter, it is measured from the default height of the subfloor for the current floor.

Once created, a camera's height can be modified in its Camera Specification dialog, and the default height value can be set in the Camera Defaults dialog. See [Camera Panel on page 1117](#).

---

## Creating Overviews

In Chief Architect, there are three different overview types: Full, Floor, and Framing Overviews.

Each type of overview can be generated as either an orthographic or perspective view. An overview window's title bar indicates whether it is perspective or orthographic. See [Perspective and Orthographic Views on page 1080](#).

Overviews generate as soon as you select the tool and are always created at the same 120° angle. The initial focal point is located at the center of the architectural model: the terrain is not taken into consideration determining its position. The distance of the camera from the model will vary depending on its size: the larger the architectural model, the further away the camera will be from the focal point so that the entire model can be seen in the view.

A new overview camera can also be created by selecting an existing overview camera in plan view and then copying and pasting it. See [Copying and Pasting Objects on page 167](#).

Once generated, an overview window's title bar indicates its view type and a camera symbol in plan view represents its location. An overview camera can be edited much like regular camera views can. See [Editing 3D Views on page 1105](#).

### FULL OVERVIEW



Select **3D> Create Orthographic View> Orthographic Full Overview** or **3D> Create Perspective View> Perspective Full Overview** to generate an exterior view of the entire model.

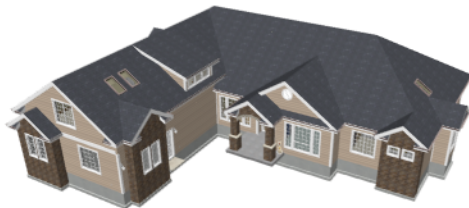



### FLOOR OVERVIEW

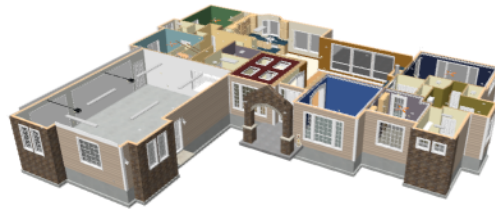

Select **3D> Create Orthographic View> Orthographic Floor Overview** or **3D> Create Perspective View> Perspective Floor Overview** to create a view of the current floor with the ceiling removed and all floors beneath it visible.

Floor Overviews are an effective tool for illustrating traffic flow and the relationships between spaces.



To see a different floor, select **Tools> Floor/Reference Display> Up One Floor**  or **Down One Floor** . You can also return to plan view and make another floor current before generating the Floor Overview.

If you prefer, you can specify in the Camera Defaults dialog that only the current floor be included in Floor Overviews. See [Camera Defaults Dialogs on page 1081](#).

### FRAMING OVERVIEW



Select **3D> Create Orthographic View> Orthographic Framing Overview** or **3D> Create Perspective View> Perspective Framing Overview** to create a view of the entire model, displaying only framing and the foundation.

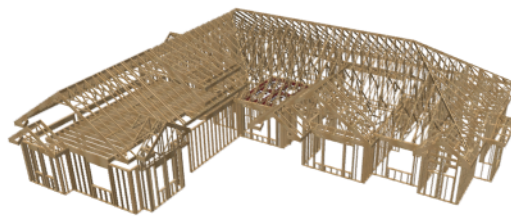

Framing overviews include all floor, wall, and roof framing as well as foundations. Unlike other overviews, which use the Camera View layer set, Framing Overviews use the 3D Framing Set. See [Layer Sets on page 182](#).

Framing must be built before generating this view or the view will be empty.

### ISOMETRIC OVERVIEWS



An Isometric Overview is a special orthographic view in which the camera is positioned in such a way that the angles between the X, Y, and Z axes are all 120° in that view. See [3D Drafting on page 13](#).



In addition, Isometric Overviews use scaling that is approximately 1.2 times that used in a normal projection so that lines parallel to the X, Y, and Z axes measure their true length in the 2D projection. As such, Isometric Overviews can be useful for technical drawings but may not be well suited for presentation views.

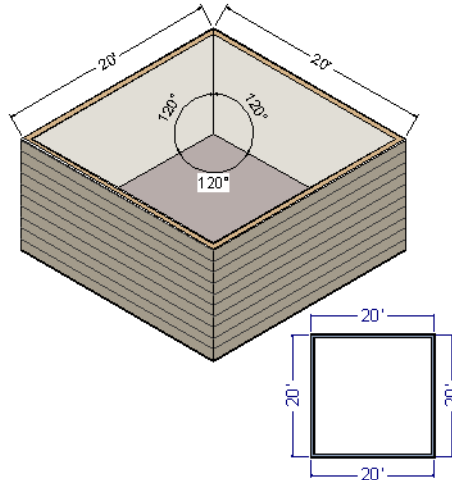



 To create an Isometric Overview, begin in an Orthographic Overview. See [Perspective and Orthographic Views on page 1080](#).

**To create an Isometric Overview**

1. Create an **Orthographic Full Overview**  or **Floor Overview** .
2. With the Orthographic view active, select **3D> Isometric Overviews** and choose a view option from the submenu.
3. The camera’s position will adjust, as will the scaling used in the view.
4. If you move, orbit, or tilt the camera, the camera will return to normal scaling.



## Cross Section/Elevation Views

The cross section/elevation tools produce the traditional, orthogonal views often used in drafting. Regardless of their distance from the camera, all lines and dimensions in these views are their true lengths, making it easy to accurately see the spatial relationships of the 3D objects in the model.

Cross section/elevation views are the only 3D views that can be enhanced with the 2D CAD tools. They can be fully annotated and dimensioned, sent to layout, and printed to scale. See [Detailing Cross Section/Elevation Views on page 1094](#).

### CREATING CROSS SECTION/ELEVATION VIEWS

Each of these tools has a specific function:

-  A **Cross Section/Elevation** view displays all floors of the model. The cross section begins at the point where the camera arrow is drawn and continues through the entire model.
-  The **Back Clipped Cross Section** tool includes only the objects or portions of objects between the starting point and stopping point of the camera’s Line of Sight.
-  The **Wall Elevation** tool creates an interior elevation of a single wall defining the room that the camera is drawn in. It creates a 2D projection of that wall and the objects located between that wall and its Cross Section Line; does not cut through walls or show the ceiling, floor, or roof; and is used primarily for kitchen and bath elevations. This tool cannot be used to create exterior views.

Additional tools allow you to create and save multiple elevation views with a single click:





The **Auto Elevation Tools** create exterior elevations of the front, back, left and right sides of the model. See [Auto Elevation Tools on page 1091](#), below.



The **Create Room Elevation Views** edit tool creates an interior elevation view of each wall defining or present in a selected room. To create elevation views for a room, select the room and then select this edit tool. See [Editing Rooms on page 419](#).

**Cross Section/Elevation, Back Clipped Cross Section, and Wall Elevation** views are created in the same way.

**To create a cross section/elevation view**

1. Select the **Cross Section/Elevation** , **Back Clipped Cross Section** , or **Wall Elevation** tool. The pointer changes to a  with crosshairs marking the position of the pointer.
2. Click and drag a line in plan view.
  - If you selected the Wall Elevation tool, you must click inside a room area.
  - A Camera symbol displays where you click, along with a Cross Section Line indicating the plane of the camera's cross section cut line.

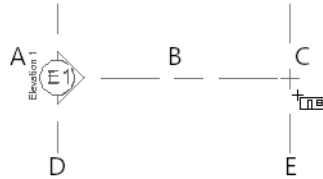

- A. Camera location (click)
- B. Line of Sight (drag)
- C. Focal Point (release)
- D. Cross Section Line
- E. Back Clipping Line (when applicable)

3. Drag in the direction of the Line of Sight to draw a camera arrow.
  - Always drag the camera arrow perpendicular to the wall to be viewed.
  - If the view is a Back Clipped Cross Section, a second Cross Section Line at the end of the Line of Sight indicates the furthest extent of the back clip.
4. When you release the mouse button, the view generates in a new window.
5. Once created, a cross section/elevation view's extents can be edited. See [Camera Panel on page 1125](#).

As with camera views, you must click and drag at least as far as your current **Snap Distance** in order to create a Cross Section/Elevation view. See [Snap Properties Panel on page 119](#).

A new cross section/elevation view can also be created by copying and pasting an existing cross section/elevation camera symbol selected in plan view. See [Copying and Pasting Objects on page 167](#).

Once created, the clipping in all cross section/elevation views can be customized to control how much of the model is included in the view. See [Camera Panel on page 1125](#).

If the Line of Sight does not cut through a 3D object and the object is within the back clipped distance, such as a window shown in elevation, the object retains its 3D definition and can be selected, moved, stretched, or otherwise modified in the view. The 3D model is updated in all views.

## AUTO ELEVATION TOOLS

 The Auto Elevation Tools create exterior elevations of the front, back, left and right sides of the model. To use any of these tools, simply select it: the camera view - or all four camera views - are automatically created, saved and named. See *Saving 3D Views on page 1115*.

At least one wall or railing must be present in the plan in order for the **Auto Elevation**  tools to work. If no walls or railings have been drawn, nothing will happen when any of these tools is selected.

The directions that these four elevation cameras point are directly related to the orientation of the X and Y axes, reference grid and snap grid in the plan. See *3D Drafting on page 13*.

The front elevation is located below the model on-screen and points upward while the back elevation is found above the model and points downward. This may not be the case, however, if you have used the **Rotate Plan View**  tool. See *Rotate Plan View on page 147*.

If the same Auto Elevation view is created more than once, the additional camera symbols are placed progressively further away from the model in plan view and are numbered. If an Auto Elevation is renamed and then the view created again, the symbols may overlap.

The **Auto Elevation Tools**  parent button can be added to the toolbars if you wish. See *To add a button to a toolbar on page 132*.

## CALLOUT LABELS

By default, cross section/elevation cameras display a callout symbol in plan view. When the view is sent to layout, the Automatic Text Below Line will report the Label of the layout page the view was sent to. To avoid unexpected results when using the Automatic Text Below Line, do not send the same camera view to layout more than once. See *Plan Display Panel on page 1128*.

---

## Clipped Section Views

The Cross Section/Elevation Specification dialog has Scene Clipping options that allow you to control the extents of the view and thus how much of the model it shows. See *Camera Panel on page 1125*.

In plan view, information about its front, back, and side clipping are indicated when a camera symbol is selected. In a clipped view, side and elevation clipping are indicated using Clip Lines on the "CAD, Clip Lines" layer. See *Displaying 3D Views on page 1097*.

## FRONT AND BACK CLIPPING

All cross section/elevation views have a clipping plane positioned at the same location as the camera and running perpendicular to its Line of Sight. This front clipping plane is also referred to as the Cross Section Line, and is shown in plan view when the camera's symbol is selected. If an object is positioned so that it is cut by this plane, its edges will be drawn but the object will not be selectable in the view.

There are two ways to adjust the position of the front clipping plane:

- Specify the camera's **X and Y Position** value in the Cross Section/Elevation Specification dialog.
- Use the camera's edit handles in plan view to reposition the start point of its Line of Sight.

By default, Back Clipped Cross Section views also have a second clipping plane: the Back Clip plane, which controls how far into the model from the camera the view extends: objects located further from the camera than the Back Clip plane are not included in the view while those located between the front and back planes are. A Back Clip can be specified for any cross section/elevation view once it has been created.



There are two ways to specify the distance between the front and back clipping planes:

- Set a specific **Back Clip After** value in the Cross Section/Elevation Specification dialog.
- Use the camera's edit handles in plan view to move the end of its Line of Sight, changing its length.

### STEPPED CUTTING PLANES

You can create one or more steps in the front and back clipping planes using the **Add Break**  edit tool, allowing you to cut some objects while avoiding others. See *Add Break on page 254*.

#### *To create a stepped cutting plane*

1. In plan view, select a **Cross Section/Elevation**  or **Back Clipped Cross Section**  camera. See *In Plan View on page 1097*.
2. Click the **Add Break**  edit button, then click on the front cutting plane of the selected camera symbol to add a new diamond-shaped Resize edit handle at the point where you clicked.

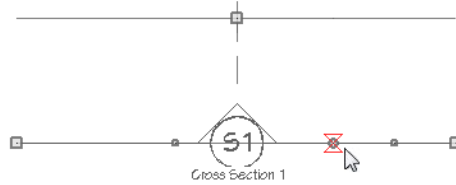

3. Click and drag the edit handle on either side of the break perpendicular to the cutting plane to create a step.

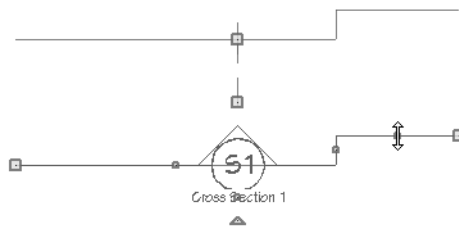

4. Click and drag the edit handle associated with the break parallel to the cutting plane to adjust the position of the step.

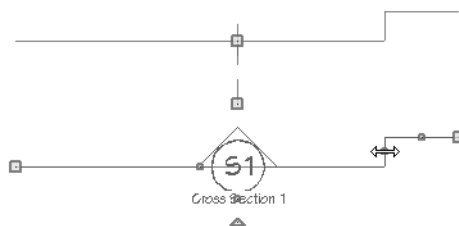

## SIDE CLIPPING

By default, cross section/elevation views include the entire width of the 3D model. You can instead choose to **Clip Sides** in the Cross Section/Elevation Specification dialog. There are three ways to specify a view's **Clip Width**:

- Set a specific value in the Cross Section/Elevation Specification dialog.
- Use the edit handles in plan view to change the length of the Cross Section Line, or front cutting plane.
- In the view itself, turn on the "CAD, Clip Lines" layer and adjust the position of the vertical Side Clip lines using the edit handles.



You can toggle side clipping in an active view by selecting **3D > Camera View Options > Clip Sides**. This option is not available for views set to Clip to Room.

## TOP AND BOTTOM CLIPPING

By default, cross section/elevation views include the entire height of the 3D model. You can instead choose to **Clip Elevation** in the Cross Section/Elevation Specification dialog. There are two ways to specify the top and bottom extents of a clipped view:

- Set a specific **Bottom** and **Top Clip Elevation** values in the Cross Section/Elevation Specification dialog.
- In the view itself, turn on the "CAD, Clip Lines" layer and adjust the position of the horizontal Elevation Clip lines using the edit handles.



When both Side and Top/Bottom Elevation clipping are in use, the Add Break and Make Parallel/Perpendicular edit tools can be used to customize the horizontal top and bottom clipping planes. These tools do not affect the vertical side clipping planes, however. See [Add Break on page 254](#) and [Make Parallel/Perpendicular on page 250](#).



You can toggle elevation clipping in an active view by selecting **3D > Camera View Options > Clip Sides**. Not available for views set to Clip to Room.

## CLIP TO ROOM

The **Clip to Room** option in the Cross Section/Elevation Specification dialog is only available when a selected view camera is located inside a room. This option is the default for Wall Elevation views, and produces a view showing a single wall defining the camera's room along with any objects between the camera and that wall. When this setting is in use, the other clipping options are disabled.

## SCENE CLIPPING AND CAMERA DEFAULTS

The default Scene Clipping settings for the Cross Section/Elevation, Back Clipped Cross Section, and Wall Elevation tools are restricted to preserve these tools' intended functions and avoid unexpected behavior; however, once a view is created using one of these tools its clipping settings are fully editable.

If you change the Scene Clipping settings of a view and then use the **Set as Default**  edit tool:

- It will update the Wall Elevation Defaults if Clip to Room is checked.
- It will update the Back Clipped Cross Section Defaults if Back Clip is checked.
- If neither of these boxes is checked, the Cross Section/Elevation Defaults will be updated.

See [Set as Default on page 79](#).

## Detailing Cross Section/Elevation Views

 CAD objects, including Text and Dimensions, can be created in cross section/elevation views. These objects are superimposed on the view and have no effect on the 3D model itself. If CAD objects have been added to a cross section/elevation view, the program will prompt you to save the view before closing the window. This information is then stored in the view. See *Saved Views on page 144*.

 Labels for cabinets and other objects can display in cross section/elevation views. See *Displaying Labels on page 700*.

A selection of Auto Elevation Dimension tools automatically generate dimension sets and story poles in cross section/elevation views. See *The Automatic Dimension Tools on page 472*.

Annotations in cross section/elevation views are created using the view's Active Defaults, which can be set in the Cross Section/Elevation Specification dialog. See *Selected Defaults Panel on page 1128*.

In cross section views, some objects, such as walls, may be represented using Cross Section lines. If a dimension line finds an object surface edge represented by a Cross Section line, a Point Marker will be placed at that location, and the dimension will locate it instead of the Cross Section line. See *Markers on page 529*.

CAD objects will snap to the Snap Grid when **Grid Snaps**  are enabled. Note that the 3D model may obscure the display of the Snap Grid. See *Grid Snaps on page 163*.

 When the Vector View rendering technique is used, you can select **CAD> CAD Detail From View** to create a 2D line drawing of the active cross section/elevation view in a CAD Detail window. This drawing can then be edited as needed. See *CAD Detail from View on page 338*.

Annotated cross section/elevation views can also be sent to layout. See *CAD and Text in Layout on page 1337*.

### AUTO DETAIL

 The Auto Detail tool automatically creates CAD objects for commonly detailed components of cross section views. To use this tool, select **CAD> Auto Detail** while a cross section view is active.

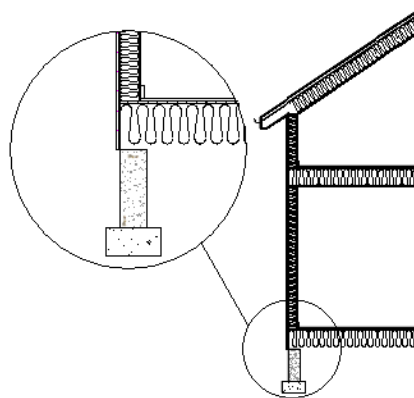

Auto Detail creates CAD objects in walls, floor and ceiling platforms, foundation walls and footings, slabs, roof and ceiling planes, as well as Material Regions and Custom Backslashes that are intersected by the cross section plane as follows:

- **Walls** - Creates closed CAD polylines for each wall layer with a fill style specified in the wall type definition. The polyline uses the same fill as that specified for the wall layer. See *Wall Type Definitions on page 384*.

- **Floors and Ceilings** - Creates closed CAD polylines for each floor and ceiling layer with a fill style specified in the Platform or Finish definition. See *Floor and Ceiling Platform Definitions on page 429*.
- **Roof and Ceiling Planes** - Creates closed CAD polylines for each roof layer with a fill style specified in its Surface, Structure, or Ceiling definition. See *Roof Layers on page 806*.
- **Foundations** - Closed polylines are created for foundation walls, footings, and floors.
  - The fill styles for wall layers are specified for the wall layer in the wall type definition.
  - The fill style for footings is “Concrete”.
  - The fill style for the floor is set in the floor platform definition.
- **Slabs** - Closed polylines using the “Concrete” fill style are created for **Slabs**. See *The Slab Tools on page 719*.
- **Material Regions** - Closed polylines for each layer of a Wall or Floor Material Region or a Custom Backsplash are created. The polylines use the fill style specified in the object’s material layers definition. See *Floor and Wall Material Regions on page 1037*.

The CAD objects created by the Auto Detail tool are placed on the Current CAD Layer. See *Current CAD Layer on page 326*.

Once created, these CAD objects can be selected and edited. See *Editing Closed Polyline-Based Objects on page 228* and *Editing Box-Based Objects on page 232*.

Note: Using the Auto Detail tool twice results in two copies of the same CAD objects.

### ***Insulation and Air Gaps***

Instead of using the fill style specified for a given structural assembly Material Layer, the Auto Detail tool can generate an **Insulation**  CAD box along the length of a structural layer. See *Insulation on page 320*.

To achieve this for a particular Material Layer, select that layer and check **Auto Detail as Insulation** in the structural component's definition. See *Wall Type Definitions Dialog on page 387* and *Material Layers Definition Dialogs on page 1040*.

Similarly, if a Material Layer has **Air Gap** checked, no CAD object will be created to detail that layer, regardless of its specified fill style.

### **DEPTH CUE**

 The **Depth Cue** tool allows you to add a partially transparent mask over part of a cross section/elevation view based on surfaces' distance from the camera. Surfaces nearer the camera are more prominent while those further are partially obscured.

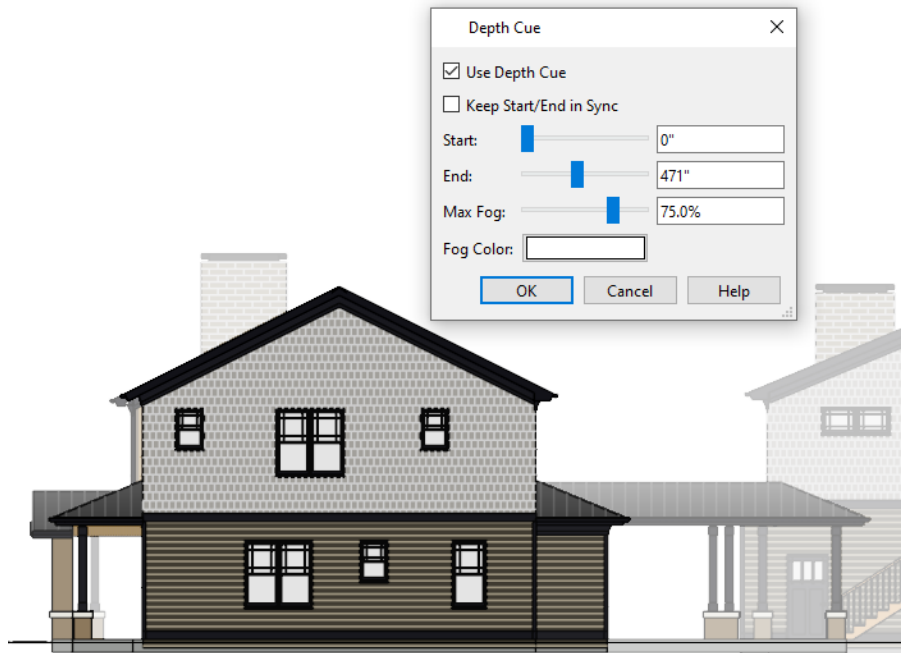

Depth Cue creates the appearance of fog over surfaces in the distance.

To add Depth Cue to an active cross section/elevation view, select **3D> Camera View Options> Depth Cue** .

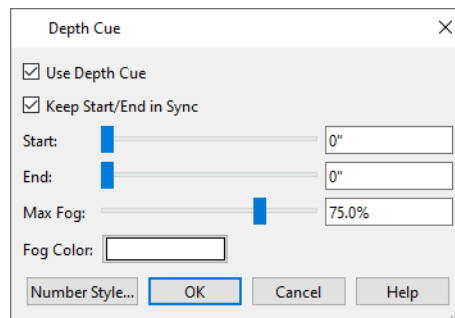

- Check **Use Depth Cue** to apply this effect to the current view and enable the settings below.
- When **Keep Start/End in Sync** is checked, the Start and End values are always the same, producing a sharp border where the fog begins. Uncheck this to produce variation in the level of fog transparency.
- Specify the **Start** and **End** distances from the camera between which the Depth Cue opacity is applied.
- Specify the **Fog Opacity**, which controls how opaque or transparent the cue is. 0% is totally transparent while 100% cannot be seen through at all.
- The **Fog Color** displays in the Color button. Click this button to choose a different color if you wish. See [Color Chooser/Select Color Dialog on page 203](#).

Depth Cue does not affect appearance of text, dimensions, or CAD objects drawn in the view.



## Displaying 3D Views

A variety of tools and settings allow you to control the appearance of 3D views. There are also numerous ways to adjust a 3D view's position, focal point and field of view. See [Editing 3D Views on page 1105](#).

The name of the current plan file and the type of view displays at the top of each view window in its title bar. If a 3D view is saved, its name also displays.

There is no limit to the number of 3D view windows that you can have open at a given time; bear in mind, though, that each window demands use of your computer's resources and that you may see poor performance if too many views are open. See [Working in Multiple Views on page 150](#).

 The 3D model will rebuild automatically as you draw; however, if you notice any anomalies in the model in 3D, select **3D> Rebuild 3D** to regenerate all 3D data associated with the current plan. All open views will remain open.

### LAYER DISPLAY OPTIONS

As in plan view, the display of objects in 3D views can be controlled by layer. See [Layer Display Options Dialog on page 179](#).

Different view types use different layer sets when they are created. See [Layer Sets on page 182](#).

To show framing in a cross section/elevation view, framing must first be built using the Build Framing dialog and the appropriate framing layers must be turned on in the Section View layer set. See [Framing on page 850](#).

To show a view's Clip Lines, turn on the "CAD, Clip Lines" layer in that view. See [Clipped Section Views on page 1091](#).

### IN PLAN VIEW

Cameras can be represented in plan view in either of two ways:

- By symbols that indicate the camera's position, field of view and focal point.

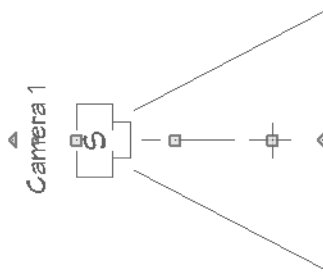

- A selected camera symbol representing a cross section/elevation view indicates its front clip plane position, line of sight, and back clip plane position if there is one.

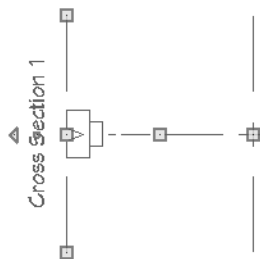

- By callouts or, for cross section/elevation views, double callouts.

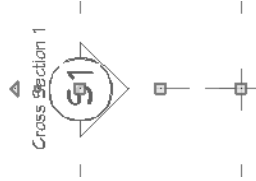



You can control the display of a camera’s focal point and line or sight, or its back clip plane indicator and line of sight, as well as specify a camera symbol or callout, in the camera’s specification dialog. See [Plan Display Panel on page 1120](#).

2D camera symbols are located on the “Cameras” layer by default; however, you can place a selected camera on any layer you wish. See [Layers on page 176](#).

By default, active camera symbols display regardless of whether the “Cameras” layer is on or off. If you prefer that their display be turned on or off with this layer, uncheck **Always Display Active Cameras** in the 3D View Defaults dialog. See [3D View Defaults Dialog on page 1083](#).

Active camera symbols and callouts use the **Selection Line** color set in the Preferences dialog. All other display attributes are derived from the “Cameras” layer. See [Colors Panel on page 98](#).

By default, the symbols for Full Overviews, Cross Section/Elevation, and Back Clipped Cross Section views display on all floors, while those for Full Cameras, Floor Overviews, and Wall Elevations display only on the floor where they were created. You can, however, specify whether any camera’s symbol displays on all floors or not in its specification dialog. See [Plan Display Panel on page 1120](#).

You can also move a camera to a different floor by clicking the **Up One Floor**  or **Down One Floor**  button while the camera view is active. Note that this may affect what is seen in the view as well as its display in plan view. See [Floor Up / Floor Down on page 737](#).

## CAMERA LABELS AND CALLOUTS

Both saved and unsaved active cameras can have labels indicating the camera or callout number or its name. Camera labels are located on the “Cameras, Labels” layer and use the Text Style assigned to that layer. See [Label Panel on page 700](#).

Camera labels and callout numbers are numbered sequentially in each plan in the order they were created unless you rename them.

- Camera labels always use the Camera Name. Saved cameras’ names can be specified in the Camera Specification dialogs. See [Camera Panel on page 1117](#).
- Saved camera callout labels and additional text can also be specified. See [Plan Display Panel on page 1120](#).
- If a cross section/elevation view using a callout is sent to layout, the layout page’s Label can display as the callout’s Text Below Line. See [Layout Page Information on page 1358](#).



Camera symbols display a letter indicating the Rendering Technique it uses. This letter uses the same text style as the camera label. See [Rendering Techniques on page 1150](#).

Camera symbols are an on-screen reference: they do not print unless **Print Image** is used and cannot be sent to layout except as an image. They are, however, included when **CAD Detail from View**  is used and in views exported to .dxf/.dwg.

In contrast, camera callouts are included when the view is sent to layout, printed, or exported and when **CAD Detail from View**  is used.

## IN RENDERED VIEWS



There are a number of factors that contribute to the appearance of rendered 3D views:

- Select **View> Color**  to toggle between color and grayscale in 3D views. See *Color On/Off on page 191*.
- Select **3D> Rendering Technique** to select a technique to apply to the current view. See *Rendering Techniques on page 1150*.
- Select **3D> Lighting> Adjust Lights**  to open the Adjust Lights dialog and edit the light sources in the current plan. See *Adjust Lights Dialog on page 1140*.
- Select **3D> Toggle Patterns**  in a rendered view with **Hand Drawn Lines on Top** enabled to turn the display of material pattern lines on or off. See *Rendering Technique Options on page 1153*.

Several other factors can contribute to the overall quality of a rendered 3D view. See *Rendering Tips on page 1132*.

## IN VECTOR VIEWS

There are also a number of factors that affect the appearance of 3D Vector Views:

- Select **3D> Toggle Patterns**  in a Technical Illustration, Watercolor, Hand Drawn Lines, or Vector View to turn on or off the display of the “Patterns, 3D Views” layer, which controls the display of material pattern lines. See *Layers on page 176*.
- Select **View> Color**  to toggle between color and black and white to control the display line and fill colors.
- The line style, color, and weight of objects in Vector Views can be specified by layer or, for some objects, individually in their specification dialogs. See *Line Style Panel on page 305*.
- The line weight, color, and style of material patterns are set in the Define Material dialog. See *Define Material Dialog on page 1066*.
- Line weights display on screen when **Show Line Weights**  is enabled. See *Line Weights on page 1371*.

## 3D BACKDROPS

A backdrop is an image, usually of an exterior view, that displays in the background of 3D views to help place the model into a realistic setting and add a sense of perspective. If a backdrop is not specified, Chief Architect applies a background color. See *3D Backdrops on page 1204*.

## RENDERING TECHNIQUES

 Any 3D view can be assigned a Rendering Technique for a range of different purposes: from detail drawings to artistic presentation views. Select **3D> Rendering Techniques** to access these tools. See *Rendering Techniques on page 1150*.

## DELETE 3D SURFACE

 The individual surfaces that make up objects can be temporarily removed from any 3D view by selecting **3D> Delete Surface** and then clicking on a surface. When the pointer is over a surface, that surface will become highlighted.

Surfaces removed in one view are removed in all 3D views, but are not permanently removed from the model. Continue clicking surfaces to remove them, then select another tool when you are finished.

Surfaces in 3D views are composed of multiple triangles. Hold the Alt key while clicking to delete one triangular face at a time rather than all triangles forming a surface. See [Edge Smoothing on page 1134](#).

To restore the most recently deleted surface, select **3D> Delete Surface**  or click the toolbar button.

There are several ways to restore all deleted surfaces:

- Select **Build> Floor> Rebuild Walls/Floors/Ceilings** .
- Exit the 3D view and reopen it.
- Generate a new 3D view.

---

## Navigating in Camera Views

Once a 3D view is created, there are many ways to manipulate the camera location and the direction of its line of site using the mouse, the keyboard, and the menus.

The Move Camera with Mouse buttons are included on the toolbars in 3D views by default; but, you can add the other tools your toolbars as well as customize their hotkeys. See [Toolbars and Hotkeys on page 128](#).



When the keyboard, toolbar buttons, or menu commands are used to move or rotate a camera, the adjustments occur in regular increments. The size of these increments is specified in the Camera Specification dialog:

- The **Incremental Move Distance** controls Panning movement and forward and backward Dolly movement.
- The **Incremental Rotate Angle** controls Orbit movement, Tilt movement, and side to side Dolly movement.

See [Camera Panel on page 1117](#).

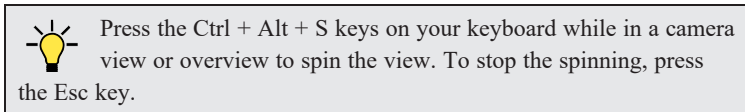
Each time you move the camera, the view is updated. If you are using either the toolbar or keyboard to move the camera, you can hold down the Shift key, suppressing the redraw of the view until the Shift key is released and allowing you to move multiple increments more quickly.



You can also move a camera to a different floor by clicking the **Up One Floor**  or **Down One Floor**  button while the camera view is active. Note that this may affect what is seen in the view as well as its display in plan view. See [Floor Up / Floor Down on page 737](#).

### MOUSE SCROLL WHEEL AND TRACKPAD

3D views can be panned and zoomed when any tool is active using the mouse scroll wheel or trackpad gestures. See [Trackpads on page 15](#).

The program adjusts the speed of these actions depending on characteristics of the camera:

- Zoom speed depends on how close the camera is to the object located behind the mouse pointer. When the target object is far from the camera, zooming is faster; as the camera gets closer to the target, zooming slows.
- Panning speed depends on the length of the camera's Line of Sight. In general, it is likely to be faster in an exterior view of a large model, slower in an interior view of a small room. See [Creating Camera Views on page 1086](#).

By default, panning and zooming adjusts the position and direction of the camera. It does not, however, adjust the distances at which surfaces are clipped. This means that if you zoom in closely on an object, some of its surfaces may be removed

from the view. One way to avoid this is to lower the camera's **Clip Surfaces Within** value in the Camera Specification dialog. See [Camera Panel on page 1117](#).

## 3DCONNEXION® 3D MICE

3Dconnexion®'s 3D mice can be used to navigate in all views - including camera views and overviews.

In the Windows version of Chief Architect, preprogrammed view direction hotkeys are supported on devices with buttons for that purpose. MacOS™ does not provide mapping support to the view direction commands; however, you can create custom hotkeys for the commands in Chief Architect and then program your 3D mouse to use those hotkeys. See [Hotkeys](#).

In Orthographic views, navigation is centered around the camera's focal point; for Perspective views, you can specify whether navigation is centered about the camera or its focal point in the Preferences dialog. See [Render Panel on page 124](#).

For best results when using a 3D mouse, uncheck **Turn Automatically** when **Camera Bumps Off Walls** is enabled. See [3D View Defaults Dialog on page 1083](#).

Rolling is not supported in Chief Architect. In addition, 3D mice cannot be used to move the mouse pointer. For details about using your 3D Connexion® mouse, refer to its documentation.

## GAMEPADS



In the Windows version of Chief Architect, gamepads can be used to navigate in camera views, overviews, and elevation views. To use a gamepad in Chief Architect, Select **Tools> Toolbars and Hotkeys> Gamepad Settings**, then check **Enable Gamepad** in the Gamepad Settings dialog. You can also adjust the sensitivity and other aspects of thumbstick functionality when used in Chief Architect. See [Gamepad Settings Dialog on page 140](#).

Note: Gamepads cannot be used in Virtual Reality. See [Virtual Reality on page 1110](#).

You can also specify whether navigation is centered about the location of the camera or its focal point in the Preferences dialog. See [Render Panel on page 124](#).





Each button on the gamepad is mapped to a command in Chief Architect. You can review and customize these commands in the Gamepad Settings dialog, as well. If you wish, you can create a custom hotkey for **Toggle Gamepad Change Height in 3D**. See [Toolbar Customization Dialog on page 134](#).

You can add the Gamepad Settings and Toggle 3D Mouse and Gamepad Navigation buttons to your toolbars if you wish. See [To add a button to a toolbar on page 132](#).

## MOVE CAMERA WITH MOUSE



An active camera's position can be edited using the mouse. Select **3D> Move Camera With Mouse** to access the Move Camera with Mouse modes, select a mode, and use the left mouse button for the primary behavior or the right mouse button for the secondary behavior. With the exception of Mouse Orbit Camera, which is available in Orthographic Overviews, these tools are not available in Orthographic views.

Tool	Primary Behavior (Left-Click)	Alternate Behavior (Right-Click)
<p><b>Mouse-Orbit Camera</b></p> 	<p>Left-click and drag to rotate the camera around its focal point. The camera's position and direction both change.</p> <p>You can temporarily activate <b>Mouse-Tilt Camera</b> by using the right mouse button while the Mouse-Pan Camera or Mouse-Tilt Camera mode is active.</p> <p>To continuously rotate the camera around its focal point, left-click in the 3D view, drag the mouse, and release the mouse button to "throw" the view. Click again in the view to stop it from rotating.</p>	<p>Right-click and drag to tilt the camera instead of orbiting.</p>
	<p>In the Mac version of the software, you can temporarily activate <b>Mouse-Orbit Camera</b> while another tool is active: hold down the Option + Shift keys, then left-click and drag. When the mouse button and keys are released, the previously active tool will again be active.</p>	
<p><b>Mouse-Pan Camera</b></p> 	<p>Left-click and drag to move the camera in any direction. The camera's position changes, but its direction does not.</p>	<p>Right-click and drag to orbit instead of panning.</p>
<p><b>Mouse-Dolly Camera</b></p> 	<p>Left-click and drag up and down to move the camera forward and backward or drag left or right to rotate the camera side to side.</p>	<p>Right-click and drag to tilt the camera instead of dollying.</p>
<p><b>Mouse-Tilt Camera</b></p> 	<p>Left-click and drag in any direction to tilt the camera, changing its view direction but not its position.</p> <p>You can temporarily activate <b>Mouse-Tilt Camera</b> by using the right mouse button while the Mouse-Orbit Camera or Mouse-Dolly Camera mode is active.</p>	<p>Right-click to orbit instead of tilting.</p>
<p><b>3D Center Camera on Point</b></p> 	<p>Lets you focus the camera at a particular point in the scene. This changes the camera's direction and focal point, but not its position.</p> <p>To use this tool, activate it and then click on any object in the scene.</p>	<p>N/A</p>

Tool	Primary Behavior (Left-Click)	Alternate Behavior (Right-Click)
<b>3D Focus on Object</b> 	Lets you focus on a specific object by changing the camera's position, direction, focal point, and the length of its line of sight.  To use this tool, activate it and then click on an object in the scene. Alternatively, select an object in the view and click the <b>Focus on Selected</b> edit button.	N/A

### MOVE CAMERA WITH KEYBOARD

An active camera's position can be changed using the Arrow keys on your keyboard. **Select 3D> Move Camera with Keyboard** to access the Move Camera with Keyboard modes. With the exception of Mouse Orbit Camera, which is available in Orthographic Overviews, these modes are not available in Orthographic views.

These modes use the Incremental Move Distance and Incremental Rotate Angle set in the active 3D view's Camera Specification dialog.

- **Keyboard-Orbit Camera** lets you use the keyboard to rotate the camera around the focal point. The camera's position and direction both change.
- **Keyboard-Pan Camera** lets you move the camera up, down, right, and left using the keyboard. The camera's position changes, but its direction does not.
- **Keyboard-Dolly Camera** lets you move the camera forward and back using the Up and Down Arrow keys, and rotate side to side using the Left and Right keys.
- **Keyboard-Tilt Camera** lets you use the Arrow keys to tilt the camera up, down, or side to side to change the focal point. The camera's direction changes, but its position does not.

Although the Arrow keys are set to move active cameras by default, you can create custom hotkeys for these commands if you prefer. See *Hotkeys on page 137*.



### MOVE CAMERA TOOLS







Select **3D> Move Camera** in a 3D view to access these tools. These tools change the active camera's position but not its direction, and are not available in Orthographic views.

 The Move Camera Forward and Move Camera Back tools allow you to "walk" up and down stairs when Camera Bumps Off Walls is checked. See *3D View Defaults Dialog on page 1083*.

These tools use the Incremental Move Distance set in the active 3D view's Camera Specification dialog.







	Description
	<b>Move Camera Forward</b> moves the camera and its focal point forward.
	<b>Move Camera Back</b> moves the camera and the focal point back.

	Description
	<b>Move Camera Left</b> moves the camera and the focal point to the left in a line perpendicular to the line of sight.
	<b>Move Camera Right</b> moves the camera and the focal point to the right in a line perpendicular to the line of sight.
	<b>Move Camera Up</b> moves the camera and the focal point up.
	<b>Move Camera Down</b> moves the camera and the focal point down.

### ORBIT CAMERA TOOLS

 Select **3D> Orbit Camera** in a 3D view to access these tools. Orbiting the camera rotates it about the focal point using the Incremental Rotate Angle set in the active view’s Camera Specification dialog.

These tools are not available in Cross Section/Elevation, Back Clipped Cross Section, or Wall Elevation Defaults views.





	Description
	<b>Move Camera In</b> moves the camera closer to the focal point along the line of sight. The camera cannot move past the focal point using this tool.
	<b>Move Camera Out</b> moves the camera away from the focal point along the line of sight.
	<b>Orbit Camera Upward</b> rotates the camera up about the focal point. The camera cannot rotate past a vertical line looking straight down on the focal point.
	<b>Orbit Camera Downward</b> rotates the camera down about the focal point. The camera cannot rotate past a vertical line looking straight up at the focal point.
	<b>Orbit Camera Left</b> rotates the camera to the left about the focal point.
	<b>Orbit Camera Right</b> rotates the camera to the right about the focal point.

### TILT CAMERA TOOLS

 Select **3D> Tilt Camera** to access these tools. Tilting keeps the camera in one place and pivots the camera about its vertical or horizontal axis. This movement uses the Incremental Rotate Angle set in the active view’s Camera Specification dialog and is similar to tilting your head up and down or turning it side-to-side.







These tools are not available in Orthographic views.



	Description
	<b>Tilt Camera Upward</b> tilts the camera up while keeping it in the same location. The camera cannot tilt beyond the vertical position.
	<b>Tilt Camera Downward</b> tilts the camera down while keeping it in the same location. The camera cannot tilt beyond the vertical position.
	<b>Turn Camera Left</b> turns the camera to the left while staying in the same location.
	<b>Turn Camera Right</b> turns the camera to the right while staying in the same location.

### VIEW DIRECTION TOOLS

-  The View Direction Tools allow you to view the model from a specific direction in a camera view or overview. While one of these views is active, select **3D> View Direction** to access these tools.

	Description
	<b>Front View</b> creates a front view of the model.
	<b>Back View</b> creates a back view of the model.
	<b>Top View</b> creates a top view of the model.
	<b>Bottom View</b> creates a bottom view of the model.
	<b>Left Side View</b> create a left side view of the model.
	<b>Right Side View</b> create a right side view of the model.
	<b>Restore Original View</b> restores the original view position.

---

## Editing 3D Views

In addition to its position and direction, there are other ways to modify a 3D view.

If you make changes to an open camera view that was saved previously, you will be prompted to resave the view when you close it.

## IN THE SPECIFICATION DIALOG

**I** You can make adjustments to a camera in its specification dialog. This dialog is particularly helpful for making fine adjustments to the camera’s position, appearance, and other attributes such as its Rendering Technique, layer set, and backdrop image. See *Camera Specification Dialogs on page 1116* and *Cross Section/Elevation Specification Dialogs on page 1124*.



Tile a 3D view and plan view and use the camera movement tools to see how they affect the camera. See *Tiling Views on page 150*.

## USING THE EDIT TOOLS

A camera symbol or symbols selected in plan view can be edited in a variety of ways using the buttons on the Edit Toolbar. See *The Edit Toolbar on page 130*.

## USING THE EDIT HANDLES

Return to plan view without closing the 3D view. See *Working in Multiple Views on page 150*.

Using the **Select Objects**  tool, select the camera object. When a camera symbol is selected, it displays six edit handles.

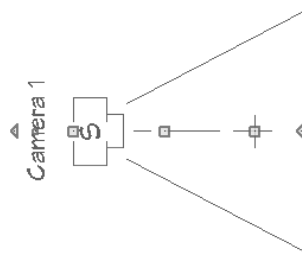

- Drag the **Rotate Label** handle or smaller **Move Label** handle to rotate or move the camera label.
- Drag the **Line of Sight** handle to change the camera angle without moving the focal point.
- Drag the **Move** handle to relocate the camera while maintaining its relative angle.
- Drag the **Focal Point** handle to reposition the focal point and change the line of sight without moving the camera.
- Drag the **Rotate** handle to rotate the camera’s line of sight about its center.

The 3D view corresponding to the camera symbol reflects changes made to the symbol in plan view.

Note: Camera callouts do not display labels, so they do not have label edit handles.

When a cross section/elevation camera is selected, it displays seven edit handles, three of which are unique to cross section/elevations.

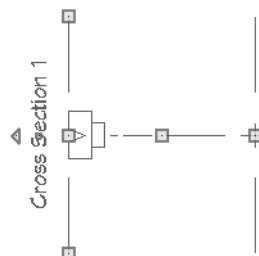

- Drag either of the two **Resize Clip Plane** handles to adjust the length of the clip plane line, which is perpendicular to the camera's line of sight. Left-click to resize the line concentrically and maintain the camera's position; right-click to move the selected end as well as the camera. This will affect what can be seen in the view if **Clip to Sides** is checked. See *Camera Panel on page 1125*.
- Drag the **Move Clip Plane** handle to move the camera and its clip plane parallel to its line of sight.
- If a stepped cutting plane is created, additional edit handles are available. See *Stepped Cutting Planes on page 1092*.

Multiple camera symbols can be selected; however, their editing options are limited to being moved, rotated, and deleted. You can also create revision clouds around group-selected camera symbols.

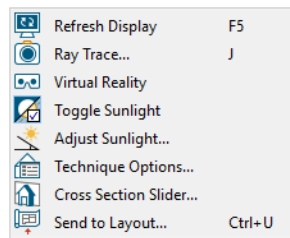

## USING THE CONTEXTUAL MENU

In a 3D view, right-click in an empty space in which the backdrop or background color displays to access the contextual menu. See *Contextual Menus on page 19*.



- In Vector Views, the options are a selection of commonly used commands from the File, Edit, Tools and Window menus.
- In the other Rendering Techniques, the options are a selection of tools and toggles specific to the current view.

## UP ONE FLOOR/DOWN ONE FLOOR

  You can move a camera to a different floor. While the camera view is active, select **Tools> Floor/Reference Display> Up One Floor** or **Down One Floor**. Note that this may affect what is seen in the view as well as its display in plan view. See *In Plan View on page 1097*.

The position and movement of a camera is affected by its location within the model. When the camera is outside a building, its height is relative to the terrain and follows the terrain as it is moved. When inside a building, the camera height is relative to the floor of the room it is drawn in.

If the camera is on an upper floor and you move the camera outside the building, the camera remains at the same height relative to the floor it was created on.

## ZOOMING

 The Zoom Tools are available in all 3D views. See *Zoom Tools on page 153*.

Selecting **Window> Zoom In** , **Zoom Out**  or **Fill Window**  does not change the camera's location or field of view. Instead, the extents of the view are expanded or cropped.

If you wish, you can instead set the **Zoom**  tools to change the Field of View when used in a 3D view. See *Render Panel on page 124*.

## FIELD OF VIEW

The Field of View refers to a camera's field of vision. A wider field of view makes the focal point appear further away, as more of the image is included in the same view window.

In plan view, the angled lines of a camera symbol indicate its field of view.

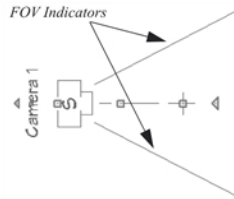

A camera's field of view can be adjusted in the Camera Specification dialog. See [Camera Panel on page 1117](#).

## Cross Section Slider



Select **3D > Camera View Options > Cross Section Slider** when a camera view or overview is active to open the Cross Section Slider dialog.

Note: The Cross Section Slider is not available when the Vector View Rendering Technique is used. See [Rendering Techniques on page 1150](#).

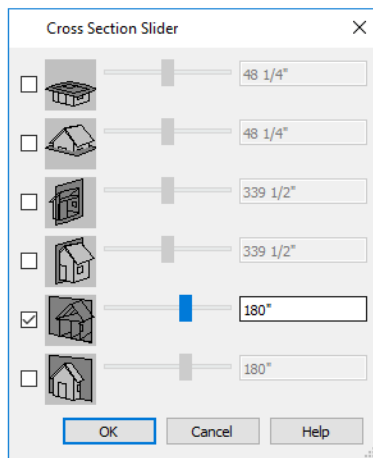

### To use the Cross Section Slider

1. Check the box beside a cross section cutting plane to select it and make its Position slider and text box active.
2. Move the Position slider to adjust the position of the cutting plane.
  - The cutting plane Position is measured from the edge of the model that is cut first by the selected cutting plane.
  - Position the Cutting Plane with accuracy using the text field to the right of the slider.
3. Repeat steps 1-3 to use additional cutting planes if you wish.
4. Click **OK** to close the dialog. If the active camera is saved, its Cross Section Slider settings will also be retained. See [Saving 3D Views on page 1115](#).

---

## Working in 3D

A variety of tools are available in 3D views that allow you to edit your 3D model as well as annotate it.

### ANNOTATING CROSS SECTION/ELEVATION VIEWS

The Text, CAD, and a selection of Dimension tools are available in cross section/elevation views, allowing you to add technical information, call attention to details, and other tasks in these views. See *Detailing Cross Section/Elevation Views on page 1094*.



The Auto Detail tool automatically creates CAD objects for commonly detailed components of cross section views. See *Auto Detail on page 1094*.





To add annotation to any other 3D Vector View, first create a line-drawn copy of the view using the **CAD Detail from View** tool. See *CAD Detail from View on page 338*.

### CREATING OBJECTS IN 3D VIEWS

You can place windows, doors, cabinets, electrical objects, corner trim, and most library objects directly into 3D views. To do this, select the appropriate tool and click in the 3D view. You can then edit the object's size and placement.

When created in 3D, most objects must be placed against a wall, on a floor platform, or within the Terrain Perimeter.

You can also click and drag to draw some CAD-based objects such as custom countertops, roof planes, terrain features and roads in camera views and overviews.

The Build Framing and Build Roof dialogs are also accessible in 3D views, although the manual **Framing Tools**  and **Roof Tools**  are not.

### SELECTING AND EDITING OBJECTS IN 3D VIEWS

Most objects can be selected and edited in 3D views. Select **Edit> Select Objects**  and click on the surface of an object to select it. Once selected, objects can be edited using their edit handles, buttons on the Edit Toolbar, and the object's specification dialog. See *Editing Objects on page 205*.

When you select an object, edit handles and a handle surface display. The handle surface is a rectangle around the perimeter of the object that indicates the overall height and width of the selected surface. The edit handles that display depend on the type of object selected. Walls, for example, display two resize edit handles when selected while the top of a cabinet displays ten handles, allowing you to move, resize and reshape it.

Note: If the wall height of the Exterior Room is adjusted in a 3D view, the default Floor or Ceiling Height of the entire floor is changed. See *Floor and Room Defaults on page 413*.

All moving or resizing is in the plane of the handle surface. You cannot move an object directly towards or away from the camera, for example, because that surface plane cannot be seen in the view.

By default, object movement is restricted to 1 inch (10 mm) increments, but this restriction can be set to custom increments in the Plan Defaults dialog and toggled off and on by selecting **Edit> Snap Settings> Grid Snaps** . See *Grid Snaps on page 163*.

Unrestricted positioning can also be enabled by holding down the Ctrl key while moving or resizing an object. See [Unrestricted Movement on page 244](#).

Temporary dimension lines display when many objects are selected to help you resize the object and determine its height. These are sometimes easier to see when the color is toggled off. See [Temporary Dimensions on page 473](#).

Because cross section/elevation views are orthogonal and display objects at their actual dimensions, they are sometimes more suitable for editing objects than camera views or overviews. See [Cross Section/Elevation Views on page 1089](#).

When several 3D views are open, changes made in the plan automatically rebuild the model in all views. Because of this, it is typically faster to make changes to your plan with as few windows open as possible.

## EDITING MATERIALS IN 3D VIEWS



Select **3D> Materials> Adjust Material Definition**, then click on a surface in the 3D view to open the Define Material dialog for that material. See [Adjust Material Definition on page 1058](#).



Select **3D> Material Painter** to apply materials to surfaces in the view using the Material Painter Tools. See [Material Painter Tools on page 1052](#).



Select **3D> Material Painter> Material Eyedropper** to apply the material on a surface in the view to other surfaces in the view. See [Material Eyedropper on page 1053](#).

## CROSS SECTION LINES

Cross Section Lines are created in cross section views to represent any objects split by the cross section line of the camera. They are placed on the “Cross Section Lines” layer, which is locked by default, and they get deleted and replaced whenever the view is redrawn.

When a dimension is drawn to locate an object split by a camera’s section line, it actually locates Cross Section Lines. So that dimensions can be retained when Cross Section Lines are regenerated, a **Point Marker**  is automatically created where a dimension meets a Cross Section Line and the dimension locates it instead of the Cross Section Line. See [Point Markers and Dimensions on page 530](#).

Cross Section Lines will print when their layer is turned on; however, they are not included when the view is sent to layout. The Point Markers created when dimensions locate Cross Section Lines, however, will both print and display in views sent to layout. See [Layout on page 1333](#).

The “Cross Section Lines” layer can be unlocked, allowing Cross Section Lines to be selected and edited. Additional CAD objects can also be placed on this layer when it is unlocked, as well; however, when the view is redrawn, all CAD objects on this layer will be deleted and replaced with a fresh set of Cross Section Lines.

## REBUILD 3D



As changes are made to your plan, a 3D view automatically updates to reflect any changes visible in the view. If you find that a view is not updating as expected, select **3D> Rebuild 3D** to rebuild the entire 3D model.

---

## Virtual Reality



The Virtual Reality option is available in the Windows version of Chief Architect and allows you to view a plan in 3D using a VR headset. To view a model in VR, select **3D> Virtual Reality** while a Perspective camera view or overview is active.

## SYSTEM REQUIREMENTS

The following virtual reality headset models are supported for use in Chief Architect:

- Oculus: Rift, Rift S, Quest (using Link Cable), Quest 2 (using Link Cable)
- HTC: Vive, Vive Pro, Vive Pro 2, Vive Cosmos, Vive Cosmos Elite
- Valve Index
- Microsoft Mixed Reality

In order to run Virtual Reality in Chief Architect, your computer should meet not only the program's system requirements but also the system recommendations provided by your VR headset manufacturer.

In addition, you must first install Steam, a game and software distribution program available at [store.steampowered.com](https://store.steampowered.com).

Once it has been installed, you must also run the SteamVR Setup so that your headset runs through the Steam software. The setup will walk you through setting up the VR sensors in a clear area, free from obstructions, where you can walk and move around.

Virtual Reality can only be activated while viewing an active Perspective View using either the Standard or Physically Based Rendering Technique. If Hand Drawn Lines on Top or GPU Ray Tracing is in use in the current view, it will be ignored in VR. See *Rendering Techniques on page 1150*.

## SAFETY CONSIDERATIONS

Virtual Reality should only be run in a space free of obstructions that could cause injury.

To avoid slow performance that could result in motion sickness, turn off any other CPU and GPU intensive applications on your system before launching Virtual Reality.

In addition, these settings are recommended in the current camera view prior to launching Virtual Reality:

- Turn Reflections off.
- Turn on a minimal number of lights and shadows.

See *Lighting on page 1135* and *Camera Specification Dialogs on page 1116*.

Just like in a Chief Architect camera view, it is possible to navigate through objects in the model when in Virtual Reality, like walls and furniture. To avoid disorientation or motion sickness, you should avoid doing so.

To avoid motion sickness while using virtual reality, gamepad style controllers are not supported. You can, however, walk within the area designated during your Steam VR Setup. To navigate to different locations in the model, you can also teleport as well as switch between Room View and Overview modes.

## ROOM VIEW AND OVERVIEW MODES

Chief Architect has two Virtual Reality modes:

- In a Room View, you can navigate a model by looking around, walking, and teleporting. Room View is active when you enter VR from a Perspective Camera view.
- In an Overview you can move and rotate the model in order to examine its exterior. Overview mode is active when you enter VR from a Perspective Overview.

Note: For best results, use the Full Camera tool for Room Views rather than Floor Camera. See *3D View Tools on page 1084*.

In both modes, your initial position and orientation in Virtual Reality are based on the position and angle of the camera. As you turn your head or walk, the view seen in the VR headset will update to reflect your movements. The original camera in Chief Architect will be unaffected, however.

Once you enter Virtual Reality, you can switch between the two modes:

- To transition from Room View to Overview, point either VR controller straight up until the Teleport Line changes to a short gray line. Press and hold the Transition button on your VR controller until the line changes entirely to the Mode Transition Color and the controller vibrates, then release the button. See *Virtual Reality Dialog on page 1113*, below.
- To transition from Overview to Room View, point either VR controller toward a valid surface on the model. Press and hold the Transition button until the line changes entirely to the Mode Transition Color and the controller vibrates, then release the button.

## NAVIGATING ROOM VIEWS

In a Room View, you can explore a model by looking around, walking in your predefined VR space, and teleporting.

To teleport to other locations within the model, press and hold the Trigger on your VR controller while aiming at a suitably flat surface. A Teleport Marker will appear at the location that you point at, and releasing the Trigger will teleport you to that location.

In Room View, the VR controller projects a Teleport Line that indicates whether a targeted surface is a valid location to teleport to. A valid surface is defined as any surface that has less than 45° pitch, however if a valid surface exists less than 12” below an invalid target location, it will show as valid and the teleport marker will be placed next to the targeted surface. This allows you to easily teleport next to an otherwise invalid surface, such as a wall or cabinet.

To cancel a teleport action, aim the Teleport Line at an invalid location. When the line changes color and the Teleport Marker disappears, release the Trigger.

In Room View, a number of navigation actions can be completed using your VR controller. These controls are the same on both right and left controllers, but specific functions differ slightly depending on the VR controller used.

Command	HTC Vive/Microsoft	Oculus Rift
<b>Teleport</b>	Trigger	
<b>Undo</b>	Trackpad Left	Thumbstick Left + Click
<b>Redo</b>	Trackpad Right	Thumbstick Right + Click
<b>Reset</b>	Menu Button	Thumbstick Up + Click
<b>Transition</b>	Trackpad Down	X or A Button
<b>Update Lighting</b>	Trackpad Upper Click	Y or B Button

## NAVIGATING OVERVIEWS

In Overview mode, you can examine and model by moving and rotating it in front of you as if holding a scaled version of the model.

In this mode, the Grip buttons on your VR controller allow you to “grab” and rotate the model. Using the Grip buttons on both VR controllers simultaneously gives a more natural rotation, as if grabbing and rotating the entire model.

Pressing and holding the Trigger allows you to drag the model in any direction: up, down, left, right, towards you, and away from you.

Pressing the Triggers while holding the Grips on both controllers simultaneously allows you to zoom in and out. Moving your hands apart will zoom in to the model, moving them closer together will zoom out.



In Overview mode, a number of actions can be completed using your VR controller. These controls are the same on both right and left controllers, but specific functions differ slightly depending on the VR controller used.

Command	HTC Vive/Microsoft	Oculus Rift
Rotate	Grip	
Drag	Trigger	
Zoom	Grip + Trigger	
Undo	Trackpad Left	Thumbstick Left + Click
Redo	Trackpad Right	Thumbstick Right + Click
Reset	Menu Button	Thumbstick Click
Transition	Trackpad Down	X or A Button
Update Lighting	Trackpad Upper Click	

### VIRTUAL REALITY DIALOG

To view a model in VR, select **3D> Virtual Reality**  while a Perspective Camera view or Overview is active. The Virtual Reality dialog will open.

Note: Neither Hand Drawn Lines on Top nor GPU Ray Tracing are supported in VR.

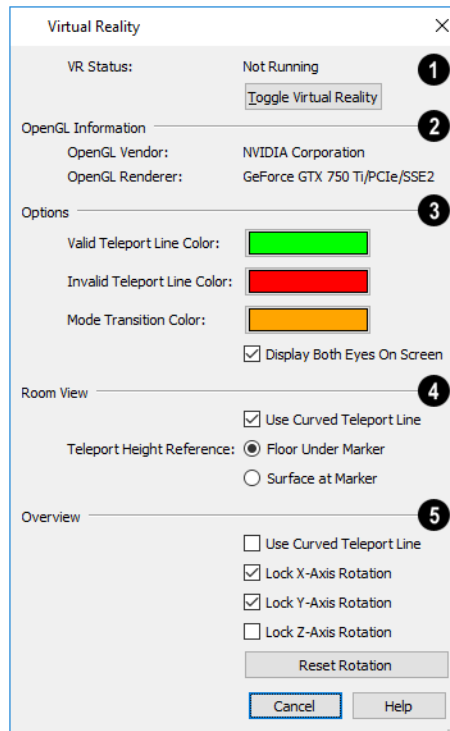

#### 1 VR Status

The current **Virtual Reality Status** is stated at the top of the dialog, along with information about graphics card or chipset being used on the computer.

- Click the **Toggle Virtual Reality** button to turn Virtual Reality on or off.

## 2 OpenGL Information

Information about your graphics card is displayed here for reference. Visit [chiefarchitect.com](http://chiefarchitect.com) for information about system requirements.

## 3 Options

- Validity of a surface is indicated by the color of the teleport line. The **Valid Teleport Line** and **Invalid Teleport Line Colors** can be set here.
- The teleport line will display the **Mode Transition Color** when switching between Room View and Overview Modes. This color can also be set here.
- When Virtual Reality is active, the program window shows what the user sees in the VR headset. By default, both eyes' views are shown in a split screen. If you would prefer to see only the left eye's view, uncheck **Display Both Eyes On Screen** in the Virtual Reality dialog.
- When **Update Lighting on Teleport** is checked, the lighting in the model will update when you teleport more than 10 feet (3 m) to ensure that your destination has lighting. Uncheck this if you prefer to only update lighting manually using the controller.

## 4 Room View

Specify how the teleport feature works in **Room View** Mode.

- **Use Curved Teleport Line** changes the teleport line from a straight line to a curved arc. This is checked by default for Room Views.
- The **Teleport Reference Height** setting determines how the camera height is calculated when the teleport feature is used.
- When **Floor Under Marker** is selected, the new camera position will calculate its height based on the floor surface, or the floor directly beneath where the teleport marker lands if locating a raised surface such as a countertop or table. This may result in being teleported inside furniture or other objects.
- When **Surface at Marker** is selected, the new camera location will determine its height from the surface where the marker landed. This will place the camera on top of objects such as furniture and may result in the view being in or above the ceiling.

## 5 Overview

Specify how the teleport feature works in **Overview** Mode.

- **Use Curved Teleport Line** changes the teleport line from a straight line to a curved arc. This is unchecked by default for Overviews.
- **Lock X-Axis Rotation** prevents the model from being tilted vertically.
- **Lock Y-Axis Rotation** prevents the model from being rolled left to right.
- **Lock Z-Axis Rotation** prevents the model from being spun horizontally.

When Virtual Reality is active, neither the camera nor the model can be edited in any way. If you wish to make modifications, you must **Toggle Virtual Reality** off in the Virtual Reality dialog, make the necessary adjustments, and then enter Virtual Reality again.

## Saving and Printing 3D Views

3D camera views, overviews, and cross section/elevation views can be saved with the plan in which they are created, exported and saved as image files, as well as sent to layout and printed.

### SAVING 3D VIEWS



Select **Tools > Active View > Save Active View** to save the current camera view in the plan. You can also save a camera view by checking the **Saved** box in the Camera Specification dialog. See [Camera Specification Dialogs on page 1116](#).



Saved cameras can be closed and re-opened for later use, and retain their Cross Section Slider, Sunlight, Shadows, and Rendering Technique settings. See [Cross Section Slider on page 1108](#), [Adjust Sunlight Dialog on page 1148](#), [Shadows on page 1133](#), and [Rendering Techniques on page 1150](#).

In addition, if CAD or Text objects are drawn in a cross section/elevation view, you will be prompted to save the view when you close it. Any CAD or Text objects added to a cross section/elevation view are saved with the view as part of the plan file.

Once a 3D view is saved, it is listed in the Project Browser and can be named. The name displays in its label with the camera symbol in plan view and in its view window tab. Camera names must be unique. See [Project Browser on page 58](#).

### ACTIVATING SAVED VIEWS

There are several ways to open a saved 3D view:

- Select the camera symbol in plan view and click the **Open View**  edit button.
- Right-click on the camera symbol in plan view and select **Open View**  from the contextual menu.
- Double-click the camera symbol using the **Select Objects**  tool.
- Double-click on the saved camera view's name in the Project Browser or right-click on it and select **Open View** from the contextual menu.

Unsaved cameras that are open in another view window can also be activated using the **Open View**  edit button.

If you open a saved camera view and then modify its location or direction using any of the tools available in that view, the program will confirm whether you want to re-save the camera using these new settings when you close it. See [Navigating in Camera Views on page 1100](#).

### CAD DETAIL FROM VIEW



In any 3D view using the Vector View rendering technique, you can select **CAD > CAD Detail From View** to generate an editable line drawing of the view in a CAD Detail window. CAD Details created from a view do not update when the model is changed. See [CAD Detail from View on page 338](#).

### EXPORTING 3D VIEWS



All 3D views can be exported and saved as .bmp, .jpg, .png, or .tif files. Select **File > Export > Picture** to save the current screen image as an image file. See [To export a picture on page 1191](#).



The **Export 360 Panorama** tool creates a spherical panoramic image file. See [Export 360 Panorama on page 1238](#).

In addition, Vector Views can be exported and saved as .emf files. See [Metafiles on page 1195](#).

Once saved, a picture can be opened and converted into many other formats using a graphics program. Picture files can be sent to layout or used in word processing, desktop publishing, and web development programs to create advertisements, brochures, etc.

## PLAN BACKUP



When transferring a plan to another computer or to another user, it is helpful to include all the Images, Textures, and Backdrops used in the plan so that rendered views are complete. The **Backup Entire Plan** tool allows you to do so. See [Backup Entire Plan or Layout on page 55](#).

## PRINTING 3D VIEWS



Since all 3D views other than Vector Views are created using pixels instead of lines, **File> Print> Print Image** must be used when printing. Print Image is a special Chief Architect function that prints the screen in picture format. The entire view prints, including images such as plants and textures.

3D views can also be sent to layout and then printed as part of your construction documents.



Select **File> Send to Layout** to send the current view to layout. See [Sending Views to Layout on page 1338](#).



Select a saved, inactive camera symbol in plan view and click the **Send Camera's View to Layout** edit button to send the view to layout.



For high quality renderings, consider using ray tracing. See [CPU Ray Tracing on page 1167](#).

## CLOSING 3D VIEWS

Although you can have any number of 3D views open at a time, to conserve resources on your computer it is a good idea to close views when you no longer need them. There are a number of different ways to do this. See [Closing Views and Files on page 155](#).

---

# Camera Specification Dialogs



The Camera Specification dialog can be accessed in plan view by selecting one or more camera symbols and clicking the **Open Object** edit button. See [In Plan View on page 1097](#).



This dialog can also be accessed while a camera view or overview is active by selecting **Tools> Active View> Edit Active View**.

The settings in this dialog may vary somewhat depending on the tool used to create the selected view. This tool name is indicated in the dialog's title bar: the specification dialog for a **Full Camera** , for example, is named Full Camera Specification. See [3D View Tools on page 1084](#).

The Camera Specification dialog has the following panels:

The settings in this dialog are also found in the Camera Defaults dialogs for each of the various camera tools. See [Camera Defaults Dialogs on page 1081](#).

## CAMERA PANEL

The CAMERA panel is also found in the Walkthrough Path Specification and Defaults dialogs. See *Walkthrough Path Specification Dialog on page 1210*.

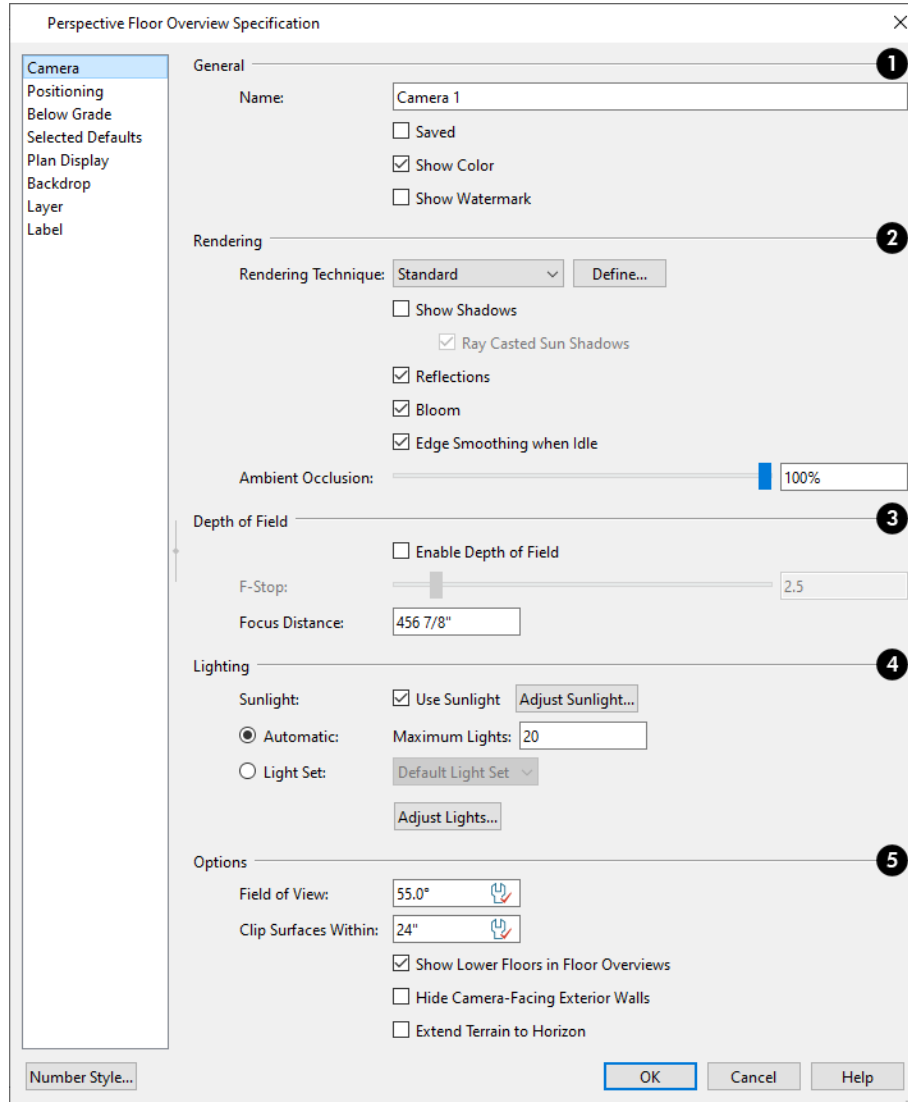

Some settings only affect some types of views. Depending on the type of camera view selected, not all the settings may be available.

### 1 General

- Specify a **Name** for the camera that displays in its label in plan view and in the Project Browser. Names must be unique. See *Project Browser on page 58*.
- Check **Saved** to save this view with the plan. As soon as you type anything in the text field, this box becomes checked. If you click OK while this box is checked, it will become checked permanently. Saved cameras are listed in the Project Browser.

- Uncheck **Show Color** to toggle the display off in the current view. See *Color On/Off on page 191*.
- Check **Show Watermark** to turn on the display of the default watermark. See *Watermarks on page 1377*.

## 2 Rendering

- Choose the selected camera or walkthrough path's **Rendering Technique** from the drop-down list.
- Click the **Define** button to open the Rendering Technique Options dialog. Any changes made in that dialog only affect the selected view or path. See *Rendering Techniques on page 1150*.
- Check **Show Shadows** to turn on shadows in the selected camera view. When unchecked, shadows are not generated. See *Shadows on page 1133*.
- Check **Ray Casted Sun Shadows** for higher quality shadows cast by sunlight. Ray Casted Sun Shadows take longer to generate than regular shadows and only refresh when the camera is not moving.

Note: Ray Casted Sun Shadows are not used in Virtual Reality. See *Virtual Reality on page 1110*.

- Check **Reflections** to turn on reflections in the selected camera view. When unchecked, reflections are not generated. See *Reflections on page 1133*.
- Light **Bloom** occurs around areas of intense illumination and looks as though the light is 'bleeding' beyond the edges of the light source. It adds realism to the view but can take longer to render. Only affects Standard, Duotone, and Watercolor renderings. See *Rendering Techniques on page 1150*.
- Check **Edge Smoothing When Idle** to apply high quality edge smoothing to edge and pattern lines when the selected camera is not in motion. See *Edge Smoothing on page 1134*.
- Select the amount of **Ambient Occlusion** in the view using the slider bar or text field. Ambient Occlusion allows variation in the strength of the ambient light. It is more realistic than uniform ambient light, but can take longer to render. Only affects Standard, Duotone, Watercolor, and Physically Based renderings. See *Ambient Lighting and Occlusion on page 1137*.

## 3 Depth of Field

These settings allow you to add blur to objects that are not in focus in the current Standard, Vector View, Physically Based, Glass House, or Technical Illustration rendering.

- Check **Depth of Field Enabled** to enable the settings below and add blur to out-of-focus objects.
- Set the **F-Stop** using the scroll bar or text field. A low value increases blur while a high value reduces blur.
- Specify the **Focus Distance**, which is the distance from the camera at which objects are in focus and no blur occurs. Objects closer to the camera than this distance are subject to blur, as are those further away from the camera.

## 4 Lighting

These settings control which and how many light sources are used in the current view. See *Light Sets on page 1139*.

- When **Use Sunlight** is checked, the sun light source is on in the current view. Uncheck this box to toggle sunlight off.
- Click the **Adjust Sunlight** button to open the Adjust Sunlight dialog. Not available in the Camera Defaults or Walkthrough Path Defaults dialogs. See *Sunlight and Moonlight on page 1136*.

- Select **Automatic**, then specify the **Maximum Number** of lights that can be used in the current camera view.
- Select **Light Set**, then choose a set from the drop-down list. Click the **Adjust Lights** button to view and modify the selected Light Set's properties. See *Adjust Lights Dialog on page 1140*.

## 5 Options

- The **Field of View** defines the camera's field of vision in angular degrees. See *Field of View on page 1108*.
- **Clip Surfaces Within** - Objects located within this distance from the camera do not display in the view. Decrease this value to display objects located close to the camera; increase it to improve the appearance of some surfaces in Overview cameras with very large extents.
- Uncheck **Show Lower Floors** to show only the current floor in the selected Floor Overview. When checked, the current floor plus any floors beneath it are included in the view. Only available for Floor Overview. See *Floor Overview on page 1087*.
- Check **Hide Camera-Facing Exterior Walls** to suppress the display of any exterior walls that face the camera. Interior walls set as Attic walls are also suppressed. This setting only has an effect when the selected camera's position is on the exterior of a structure and also has an associated toggle. See *Hide Camera-Facing Exterior Walls on page 1135*.
- Check **Extend Terrain to Horizon** to create a virtual extension of the Terrain Perimeter in camera views that appears to extend to the horizon. This setting only has an effect if a Terrain Perimeter is present. See *Terrain Perimeter on page 1244*.

## POSITIONING PANEL

Only the X and Y Position settings are available in the Cross Section/Elevation Specification dialog. See *Cross Section/Elevation Specification Dialogs on page 1124*.

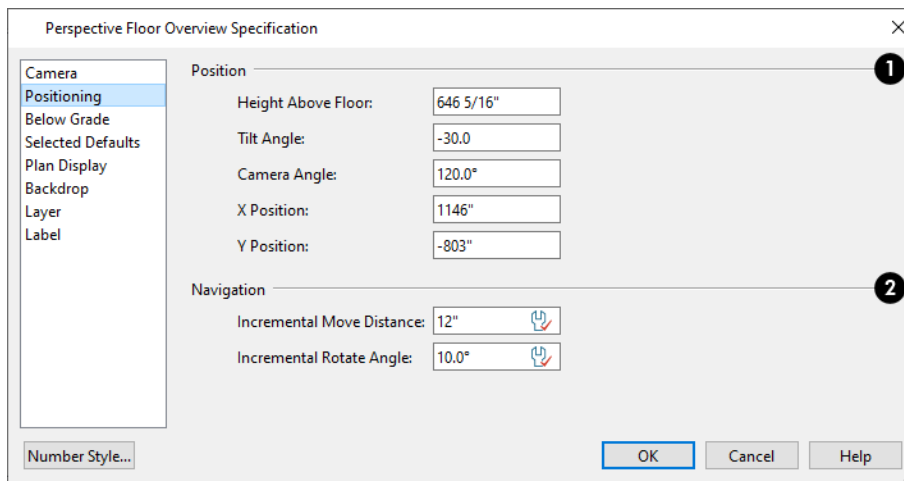

## 1 Position

These settings determine the position and orientation of the camera. Only the Height Above Floor and Tilt Angle are available in the Camera Defaults dialogs. See *Navigating in Camera Views on page 1100*.

- The **Height Above Floor** defines the height that the camera is above the floor level for the current floor. See *Camera Height on page 1087*.

- The **Tilt Angle** determines the vertical angle that the camera is tilted. The camera maintains its focal point and position in plan view, but if the camera is tilted, the focal point is above or below the current camera height.
- Specify the selected camera's **Camera Angle**. This is an absolute value: an angle of 0° points the camera toward the left in plan view.
- Specify the **X Position** and **Y Position** for the selected camera. These are absolute coordinates. Specifying zero for both places the camera at the plan's origin point (0,0).

## **2** Navigation

These settings control how the camera is affected when you navigate using the mouse. See [Move Camera with Mouse on page 1101](#).

- The **Incremental Move Distance** controls how far the camera moves each time you Pan in any direction or Dolly forwards or backward using the keyboard, toolbar buttons, or menu. For interior views a small number is good, but for exterior you may want a larger increment.
- The **Incremental Rotate Angle** defines how many degrees the camera rotates each time you Tilt, Orbit, or Dolly side to side using the keyboard, toolbar buttons, or menu. A setting of 90° would make one full rotation in four moves.

## **BELOW GRADE PANEL**

The settings on the BELOW GRADE panel control the appearance of objects positioned below grade. These settings only affect Vector Views and are also found in the Cross Section/Elevation Specification dialog. See [Below Grade Panel on page 1127](#).

## **SELECTED DEFAULTS PANEL**

The settings on the SELECTED DEFAULTS panel control which Saved Defaults and layer settings are used in the view. These settings are also found in the Active Defaults dialog. See [Active Defaults Dialog on page 82](#).

## **PLAN DISPLAY PANEL**

The settings on the PLAN DISPLAY panel control the appearance of the selected camera's symbol in plan view. See [In Plan View on page 1097](#).



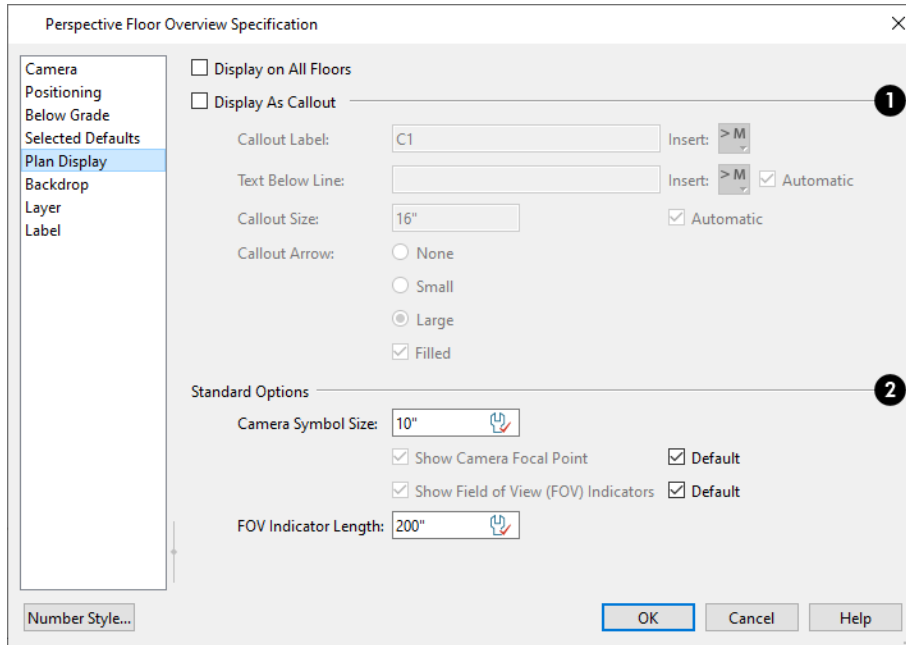

### 1 Display on All Floors

Check this box to display the selected camera’s symbol on all floors. When unchecked, it only displays on the floor where the camera was created. See [Creating Camera Views on page 1086](#).

### 2 Display as Callout

Check this box to use a callout symbol to represent the selected camera and enable the settings that follow:

- Specify the **Callout Label**, which is the text that displays inside the callout circle. If no **Text Below Line** is specified, the Callout Label is centered in the callout.
- Specify the **Text Below Line** for a bottom row of text, if desired. Check **Automatic** to populate the Text Below Line with the camera’s Name, as specified on the [Camera Panel on page 1117](#). See [Camera Labels and Callouts on page 1098](#).
- To specify the **Callout Size**, uncheck **Automatic** and then type in the text field. When Automatic is checked, the size is based on the length of the Callout Label and the size of the current Text Style.
- Specify the appearance of the **Callout Arrow**. Choose **None**, a **Small** arrow, or a **Large** arrow. Uncheck **Filled** if you do not want a solid filled arrow.

Note: A camera callout arrow will only display its solid fill when the camera view is not open. When the view is open, the arrow will display as transparent.

### 3 Standard Options

These settings allow you to specify the appearance of the selected camera’s standard symbol. Most of these options are disabled when **Display As Callout** is unchecked, above.

- The **Camera Symbol Size** is measured in plan inches (mm).
- Check **Show Camera Focal Point** to display the camera's focal point in plan view. When unchecked, the camera's line of sight and focal point are hidden until the camera is selected.
- Check **Show Field of View Indicators** to display the camera's field of view indicators in plan view.
- You can also change the **FOV Indicator Length**, which is measured in plan inches (mm).

## BACKDROP PANEL

The settings on the Backdrop panel allow you to specify a backdrop image or color to display behind your model in the selected 3D view. See *3D Backdrops on page 1204*.

The BACKDROP panel is also found in the Walkthrough Path Specification and Defaults dialogs. See *Walkthrough Path Specification Dialog on page 1210*.

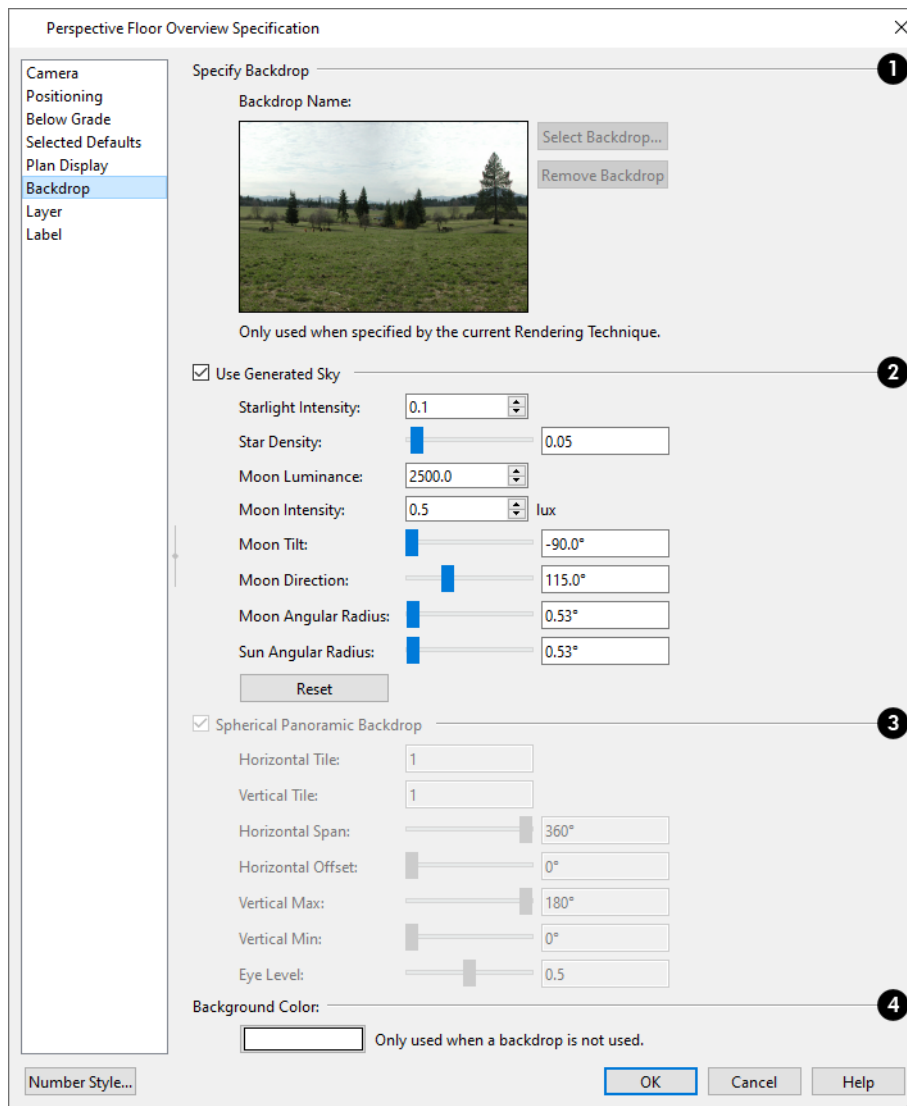

### 1 Specify Backdrop

A preview of the selected backdrop image is shown here. A backdrop cannot be selected or removed when Use Generated

Sky is checked, below.

- **Backdrop Name** - The selected backdrop image's name displays for reference.
- Click **Select Backdrop** to choose a backdrop image from the library. See *Select Library Object Dialog on page 974*.
- Click **Remove Backdrop** to use a solid color instead of a backdrop image in all 3D views, then specify the color below.

## 2 Use Generated Sky

Not available for Orthographic Overviews or Cross Section/Elevation views, and is not used in CPU Ray Tracing.

- Check **Use Generated Sky** to use a sky backdrop that simulates different times of day based on the position of the Generic Sun. When checked, Spherical Panoramic Backdrop will also be checked and a preview of the Generated Sky will display in the current view behind the dialog, and will update as changes are made to the settings below.
- Specify the **Starlight Intensity**, which is how bright the stars appear in the sky.
- Specify the **Star Density**, which controls how close stars are to one another.
- Specify the **Moon Luminance**, which is how much light the moon contributes to the scene.
- Specify the **Moon Intensity**, which is how bright the moon appears in the sky.
- Specify the **Moon Tilt**, which is the direction that the moon's light shines.
- Specify the **Moon Direction**, which describes the position of the moon in the sky.
- Specify the **Moon Angular Radius**, which controls the size of the moon.
- Specify the **Sun Angular Radius**, which controls the size of the sun.
- Click the **Reset** button to reset all Generated Sky settings to the system defaults.

## 3 Spherical Panoramic Backdrop

These settings are only available when a Backdrop image is selected, and are not available for Orthographic Overviews or Cross Section/Elevation views. When User Generated Sky is checked, above, these settings cannot be edited.

- Check **Spherical Panoramic Backdrop** to place the selected backdrop onto a sphere that surrounds the model in the current view. This box is checked automatically when Use Generated Sky is checked, above.
- **Horizontal Tile** - Specify how many times to tile the selected backdrop image side by side.
- **Vertical Tile** - Specify how many times to stack the selected backdrop image one above the other.
- Specify the **Horizontal Span**, which is how much of the sphere the backdrop is applied to. A Span of 360° wraps the entire sphere.
- Specify the **Horizontal Offset**, in degrees, to shift the backdrop image or tiled images in a clockwise direction.
- Specify the **Vertical Max**, which is the height of the bottom of the backdrop, measured relative to the top of the sphere.
- Specify the **Vertical Min**, which is the height of the bottom of the backdrop, measured relative to the bottom of the sphere.
- The **Eye Level** setting controls the vertical position of the camera within the sphere. A value of 0 positions the camera at the bottom of the sphere while a value of 1 positions it at the top. The default value is 0.5., which centers the camera inside the sphere.

## **4** Background Color

- Click the Color bar to select the **Background Color** that displays when a backdrop image is not being used. See *Color Chooser/Select Color Dialog on page 203*.

The Background Color for plan views and CAD Details is set in the Preferences dialog. See *Colors Panel on page 98*.

### **LAYER PANEL**

The setting on the LAYER panel lets you choose which layer the selected camera's plan view symbol is placed on. For more information, see *Layer Panel on page 186*.

### **LABEL PANEL**

In the Camera Specification dialogs, the settings on the LABEL panel are limited to the **Suppress Label** check box and **Position** and **Orientation** settings.

Camera labels always use the **Camera Name** specified on the CAMERA panel. When callouts are used, the **Callout Label** and **Text Below Line** are specified on the PLAN DISPLAY panel.

For information about this panel, see *Label Panel on page 700*.

---

## **Cross Section/Elevation Specification Dialogs**



The Cross Section/Elevation Specification dialogs can be accessed in plan view by selecting one or more cross section/elevation camera symbols and clicking the **Open Object** edit button. See *In Plan View on page 1097*.



This dialog can also be accessed while a cross section/elevation view is active by selecting **Tools> Active View> Edit Active View**.

The Cross Section/Elevation dialog has the following panels:

Most of the settings in this dialog are also found in the Cross Section/Elevation, Back Clipped Cross Section, and Wall Elevation Defaults dialogs. See *Camera Defaults Dialogs on page 1081*.

## CAMERA PANEL

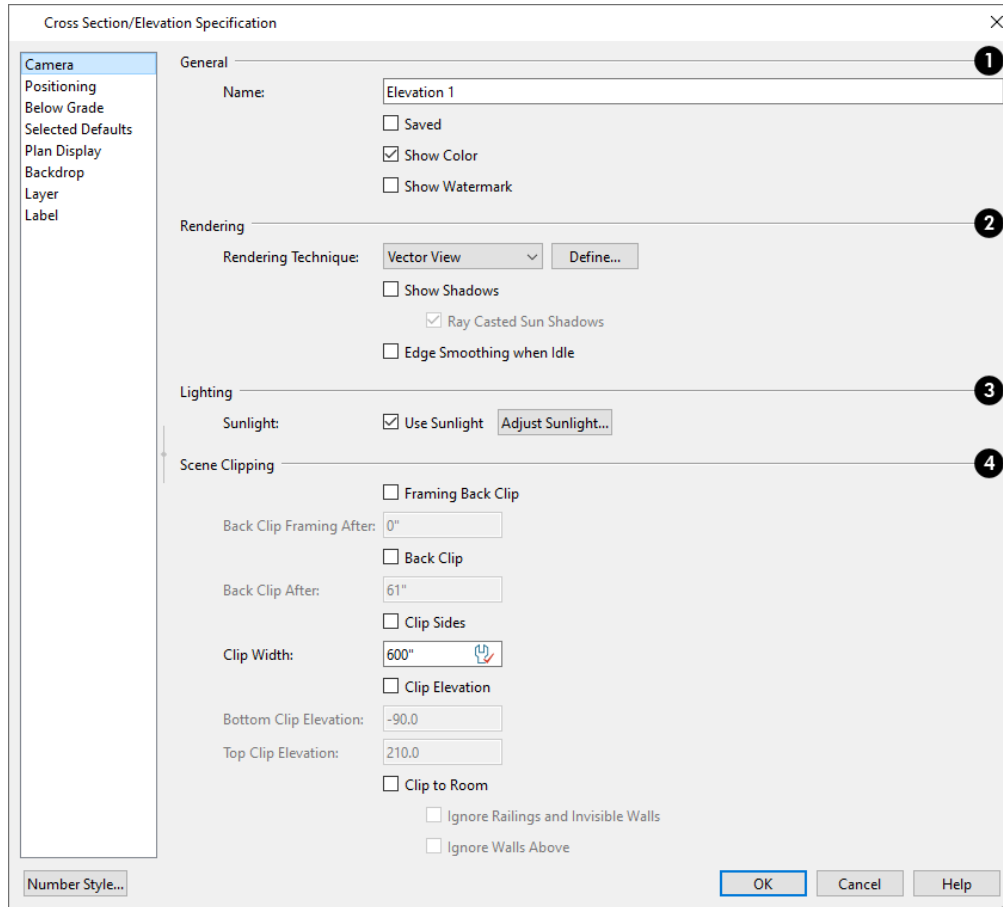

### 1 General

- Specify a **Name** for the camera that displays in its label in plan view and in the Project Browser. Names must be unique. See [Project Browser on page 58](#).
- Check **Saved** to save this view with the plan. As soon as you type anything in the text field, this box becomes checked. If you click OK while this box is checked, it will become checked permanently. Saved cameras are listed in the Project Browser.
- Uncheck **Show Color** to toggle the display off in the current view. See [Color On/Off on page 191](#).
- Check **Show Watermark** to turn on the display of the default watermark. See [Watermarks on page 1377](#).

### 2 Rendering

- Choose the selected camera's **Rendering Technique** from the drop-down list. Click the **Define** button to open the Rendering Technique Options dialog. See [Rendering Techniques on page 1150](#).
- Check **Show Shadows** to turn on shadows in the selected camera view. When unchecked, shadows are not generated. See [Shadows on page 1133](#).

- Check **Ray Casted Sun Shadows** for higher quality shadows cast by sun light. Ray Casted Sun Shadows take longer to generate than regular shadows and only refresh when the camera is not moving.
- Check **Edge Smoothing When Idle** to apply high quality smoothing to edge and pattern lines when the camera is not in motion. See [Edge Smoothing on page 1134](#).

### 3 Lighting

- When **Use Sunlight** is checked, the sun light source is on in the current view. Uncheck this box to toggle sunlight off.
- Click the **Adjust Sunlight** button to open the Adjust Sunlight dialog. Not available in the Camera Defaults dialogs. See [Sunlight and Moonlight on page 1136](#).

### 4 Scene Clipping

These settings control the extents of the camera view. Not all settings are available in the various cross section/elevation defaults dialogs. See [Clipped Section Views on page 1091](#).

- Check **Framing Back Clip** to include only the framing objects or portions of framing objects located between the start and end points of the camera's Line of Sight in the view.
- Specify the **Back Clip Framing After** distance, which is the distance from the camera's position beyond which framing objects are clipped.
- Check **Back Clip** to include only the objects or portions of objects located between the start and end points of the camera's Line of Sight in the view. This box is checked by default for Back Clipped Cross Section views and is not available in any of the Defaults dialog.
- Specify the **Back Clip After** distance, which is the distance from the camera's position beyond which objects other than framing are clipped. It is also the length of the camera's Line of Sight from the Cross Section Line at its start to the Back Clip Line at its end. This text field reports the length of the camera's Line of Sight even when Back Clip is unchecked above, and is not available in any of the Defaults dialogs.
- Check **Clip Sides** to limit the selected view's side-to-side extents to the Clip Width specified below. When unchecked, the full width of the model is included in the view.
- Specify the **Clip Width**, which is the width of the camera's side-to-side extents. This value controls the length of the camera's Cross Section Line when its symbol is selected in plan view. When Clip Sides is checked, it also affects how much of the model is shown in the view, and the Cross Section Line has end edit handles that adjust this value when they are dragged. See [Editing 3D Views on page 1105](#).
- Check **Clip Elevation** to limit the selected view's vertical extents to the elevation values below. When unchecked, the full height of the model is included in the view.
- Specify the **Bottom Clip Elevation**, which is the bottommost extent of the view. Objects or parts of objects located below this elevation are not included in the view. When Clip Sides is checked and the bottom clipping plane has been edited, this value refers to the end point with the higher elevation.
- Specify the **Top Clip Elevation**, which is the topmost extent of the view. Objects or parts of objects located above this elevation are not included in the view. When Clip Sides is checked and the top clipping plane has been edited, this value refers to the end point with the lower elevation.

- Check **Clip to Room** to confine the extents of the current view to the room that the camera is located in. The view's clip values are reported above for reference. This box is checked by default for Wall Elevation views, is only available when the selected camera is located inside a room, and is not available in any of the Defaults dialogs.
- Check **Ignore Railings and Invisible Walls** to ignore the room definition created by these types of walls in a selected view. When this is unchecked, only room definition created by regular walls is recognized.
- Check **Ignore Walls Above** to prevent any walls located above the selected camera's room from displaying in the view. This option typically has an effect only when the camera's room has Flat Ceiling Over This Room unchecked, or the room above has Floor Under This Room unchecked, in the Room Specification dialog. See [Structure Panel on page 439](#).

## POSITIONING PANEL

The settings on the POSITIONING panel let you specify the location of the camera symbol in plan view. See [Positioning Panel on page 1119](#).

## BELOW GRADE PANEL

The settings on the BELOW GRADE panel control the appearance of objects positioned below grade. These settings only affect Vector Views.

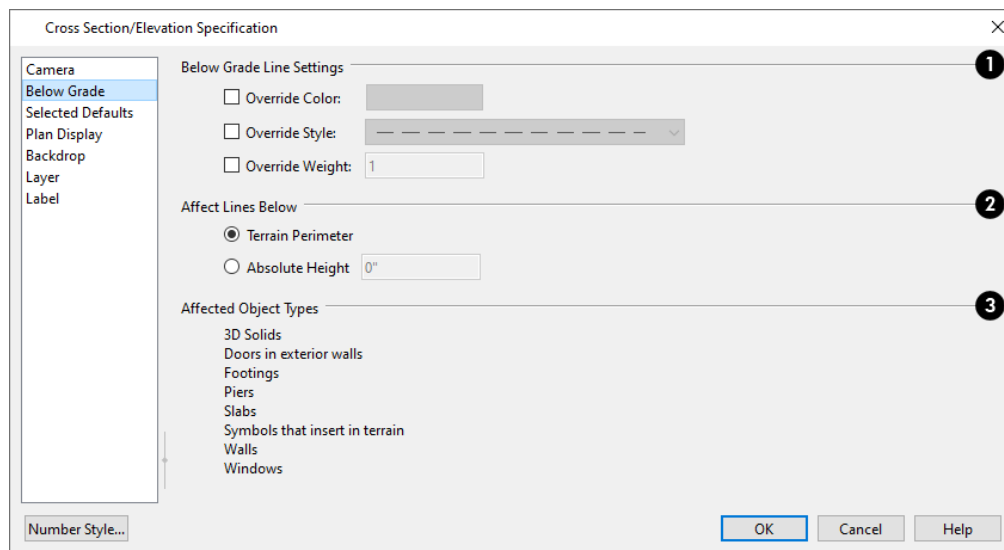

### 1 Below Grade Line Settings

Specify the appearance of lines that are below grade in the current view. When a box below is unchecked, objects' default line attributes are used.

- Check **Override Color** to replace the default object line color(s), then click the Color button to choose the replacement color.
- Check **Override Style** to replace the default object line style(s), then select the replacement line style from the drop-down list.
- Check **Override Weight** to replace the default object line weight(s), then specify the replacement line weight.

### 2 Affects Lines Below

Specify where the selected Overrides are applied.

- Select **Terrain Perimeter** to apply Overrides below the top surface of the terrain. For best results, **Auto Rebuild Terrain** should be checked in the Terrain Specification dialog. If the terrain's contours are not up to date, you may be prompted to rebuild it. See *Building the Terrain on page 1256*.
- Select **Absolute Height** and then specify the height of a horizontal plane below which Overrides are applied, measured from zero.

### 3 Affected Object Types

The types of objects affected by the line setting overrides are listed here for reference.

## SELECTED DEFAULTS PANEL

The settings on the SELECTED DEFAULTS panel control which Saved Defaults and layer settings are used in the view.

These settings are also found in the Active Defaults dialog. See *Active Defaults Dialog on page 82*.

## PLAN DISPLAY PANEL

The settings on the PLAN DISPLAY panel control the appearance of the selected camera in plan view. See *In Plan View on page 1097*.

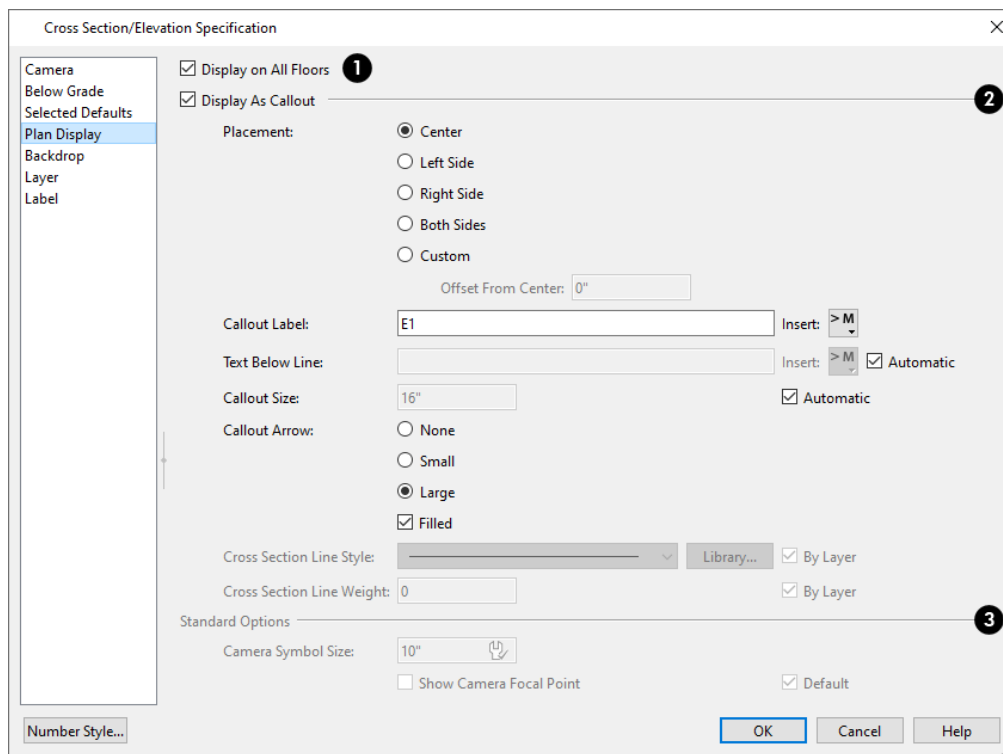

### 1 Display on All Floors

Check Display on All Floors to display the selected camera's symbol in plan view on all floors. When unchecked, it only displays on the floor where the camera was created. See *Creating Camera Views on page 1086*.

### 2 Display As Callout

In order for a camera's symbol to be included when sent to layout, printed, or exported, it must be set to Display as Callout.



- Check **Display as Callout** to represent the selected camera with a callout symbol in plan view and enable the settings below.
- Specify the callout **Placement**, either at the Center, Left Side, Right Side, or Both Sides of the clip plane. If Center or Custom is selected, no clip plane line displays.
- When Custom is the specified Placement, specify the camera icon's **Offset from Center**.
- Specify the **Callout Label**, which is the text that displays inside the callout circle. If no Text Below Line is specified, the Callout Label is centered in the callout.
- Specify the **Text Below Line** for a bottom row of text, if desired. Check **Automatic** to populate the Text Below Line with the layout page Label if the selected view is sent to layout. If no layout page Label is specified, no automatic Text Below Line will be created. See *Camera Labels and Callouts on page 1098*.
- To specify the **Callout Size**, uncheck **Automatic** and then type in the text field. When Automatic is checked, the size is based on the length of the Callout Label and the size of the current Text Style.
- Specify the appearance of the **Callout Arrow**. Choose **None**, a **Small** arrow, or a **Large** arrow. Uncheck **Filled** if you do not want a solid filled arrow.

Note: To help distinguish it from other cameras, if a camera view is open, its callout label will display unfilled in plan view regardless of its settings. It will appear as expected if sent to layout or printed, however.

- Specify the **Cross Section Line Style**. Not available when Center or Custom is selected, above, unless the cross section line is stepped. Check **By Layer** to use the line style specified for the selected callout's layer, or choose a line style from the drop-down list or the **Library**. See *Stepped Cutting Planes on page 1092*.
- Specify the **Cross Section Line Weight**. Not available when Center or Custom is selected, above, unless the cross section line is stepped. Check **By Layer** to use the line weight specified for the selected callout's layer, type a line weight in the text field.

### 3 Standard Options

These settings allow you to specify the appearance of the selected camera's standard symbol. Most of these options are disabled when **Display As Callout** is unchecked. See *Dynamic Defaults on page 79*.

- Uncheck **Default** beside any of these options to modify it.
- The **Camera Symbol Size** is measured in plan inches (mm).
- Check **Show Camera Focal Point** to display the camera's focal point in plan view. When unchecked, the camera's line of sight, focal point, and clip plane indicators are hidden until the camera is selected.
- Specify the **Clip Plane Indicator Length** in plan inches (mm). See *To create a cross section/elevation view on page 1090*.

## BACKDROP PANEL

The settings on the BACKDROP panel allow you to specify a backdrop image or color to display behind your model in the selected 3D view. See *Backdrop Panel on page 1122*.

## LAYER PANEL

The setting on the LAYER panel lets you choose which layer the selected camera's plan view symbol is placed on. For more information, see *Layer Panel on page 186*.

## **LABEL PANEL**

In the Cross Section/Elevation Camera Specification dialog, the settings on the LABEL panel are limited to the **Suppress Label** check box and **Position** and **Orientation** settings.

Camera labels always use the **Camera Name** specified on the CAMERA panel. When callouts are used, the **Callout Label** and **Text Below Line** are specified on the Plan Display panel.

For information about this panel, see *Label Panel on page 700*.

# 3D Rendering

## Chapter 33

There are a variety of tools available to create 3D views of a model: simply click a button to create an overview, or click and drag to create a camera or cross section/elevation view. See *3D Views on page 1079*.

To improve the quality of the rendering and create a custom look, you can adjust lighting, edit the materials used in the plan, choose from a variety of rendering techniques, and fine-tune 3D view quality settings.

You can also use CPU Ray Tracing to create highly realistic images of your Chief Architect plans. As the name implies, ray tracing calculates the rays of light in a view as they travel through the 3D model and reflect off surfaces. As a result, ray tracing is slower than regular rendering, but can be used to achieve much more complex effects such as complex reflections and highly realistic lighting. See *CPU Ray Tracing on page 1167*.

### TOPICS

<b>Rendering Tips</b> .....	<b>1132</b>
<b>Lighting</b> .....	<b>1135</b>
<b>Light Types</b> .....	<b>1137</b>
<b>Displaying Lights</b> .....	<b>1138</b>
<b>Light Sets</b> .....	<b>1139</b>
<b>Light Specification Dialog</b> .....	<b>1142</b>
<b>Sun Angles and Shadows</b> .....	<b>1143</b>
<b>Sun Angle Specification Dialog</b> .....	<b>1145</b>
<b>Adjust Sunlight Dialog</b> .....	<b>1148</b>
<b>Rendering Techniques</b> .....	<b>1150</b>
<b>Rendering Technique Options</b> .....	<b>1153</b>

## Rendering Tips

There are a variety of factors which affect the appearance and quality of rendered 3D views. You can use these tools and settings to achieve renderings that meet your needs.

### GPU RAY TRACING

On Windows systems that support it, GPU Ray Tracing produces highly realistic lighting, shadows, and effects such as refraction in real time using the Graphical Processing Unit (GPU). GPU Ray Tracing calculates the paths of light rays in the scene and can be used in 3D views using the Physically Based and Clay Rendering Techniques. See *Rendering Techniques on page 1150*.

When GPU Ray Tracing is active in a view, multiple samples of indirect lighting in the scene are created, improving the lighting quality and removing image noise with each sample. By default, samples are run as long as a given view is active; you can, however, specify the Maximum Export Samples to be used when the view is exported as a picture or sent to layout, and you can also specify that samples in the view be capped at that value instead of running indefinitely. The current number of samples is reported in the Status Bar. See *Physically Based (Ray Trace) Panel on page 1156* and *The Status Bar on page 24*.

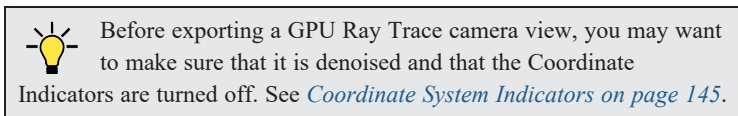

GPU Ray Tracing can also be used when recording a Walkthrough. Each frame will use the Maximum Export Samples value and Denoise setting, and will take considerably more time to record. See *Recording a Walkthrough on page 1215*.

You can find out if your computer's graphics card supports GPU Ray Tracing in the Preferences dialog. See *Video Card Status Panel on page 125*.

In other Rendering Techniques in which lighting is supported, GPU Ray Tracing enhances the quality of shadows and ambient occlusion only. For troubleshooting purposes, you can turn this feature off or on in the Preferences dialog. See *Render Panel on page 124*.

If your system does not support GPU Ray Tracing, you can instead use CPU Ray Tracing to produce renderings with high quality lighting and effects. CPU Ray Tracing runs in its own process using the computer's processor, so you can let it run in the background while continuing to work in Chief Architect. See *CPU Ray Tracing on page 1167*.

### Denoising



GPU Ray Trace views are initially grainy, or noisy, and improve in quality over time as more samples are taken. The **Denoise View** tool removes light artifacts and the appearance of graininess from an active GPU Ray Trace view: either while a real-time ray trace is process or once it is completed. Select **3D > Camera View Options > Denoise View** to replace the current live GPU Ray Trace View with a temporary, offline version that has been denoised; select Denoise View again to return to the original view.

Because denoising does not occur in a live view, you cannot navigate or interact with the model in a denoised view. If you move the camera, modify the scene's lighting, or modify the model, the denoised view will be removed and you will return to the original view where sampling will restart.

You can specify that GPU Ray Trace views be automatically denoised when exported, printed, or recorded in a walkthrough in the Rendering Technique Options dialog. See *Physically Based (Ray Trace) Panel on page 1156*.

There are a number of situations where you may want to denoise a GPU Ray Trace view:

- Preparing for a high quality ray trace: Denoise a view in which relatively few samples have been taken to see if you need to make changes to the model, lighting, or camera.
- Creating a high quality ray trace: Run a ray trace with a high number of samples and denoise for extra quality when it is finished.
- Recording a Ray Traced Walkthrough: Specify a moderate number of samples and then denoise each frame.

## LIGHTING

Lighting is extremely important in most 3D renderings, in ray tracing, and in VRML file export. Lighting controls the visibility of objects in a view, affects the appearance of surfaces, and influences the appearances of colors and textures on those surfaces. Even small changes to light intensity, direction and color can have a large impact on image quality. See [Lighting on page 1135](#).

## SHADOWS



Like lighting, shadows have an important effect on image quality. Shadows can be generated in any type of camera view using any Rendering Technique aside from Glass House. See [Rendering Techniques on page 1150](#).

When shadows are enabled and the sun is shining directly at a window, its light can shine through the window and into an interior room. These shadows use **Ray Casted Sun Shadows** by default, but this option can be unchecked if it slows performance in 3D views. See [Sunlight and Moonlight on page 1136](#).

Shadows are enabled in Full Camera views by default. You can, however, check or uncheck **Show Shadows** and **Ray Casted Sun Shadows** in the defaults dialog for any camera tool or in the specification dialog for any camera view. In addition, you can select **3D> Camera View Options> Toggle Shadows**  in any camera view. See [Camera Panel on page 1117](#).

Shadows are affected by the number of light sources in a plan, as well as what Rendering Technique is in use. In order for a light source to cast shadows, it must be **On** in the current view and have **Cast Shadows** checked in its specification dialog. See [Light Data Panel on page 675](#).

In addition to their appearance in camera views, sun shadows can also display in plan view to represent the shadows created by the sun at a particular date, time, and location. See [Sun Shadows on page 1144](#).

## REFLECTIONS



Reflections are another aspect of lighting that can increase a 3D view's realism. When a flat surface is assigned a Mirror material, it can display the reflections of other objects in the scene. Bear in mind that a Mirror surface cannot display the reflection of another mirror: when one mirror can be seen in another, its material is shown rather than a reflection. A material can be assigned the Mirror class in the Define Material dialog. See [Properties Panel on page 1072](#).

Reflections in Mirrors only generate in Perspective 3D views using Rendering Techniques that show material textures. In some situations, they can slow down 3D view generation and responsiveness. See [Rendering Techniques on page 1150](#).

When the **Physically Based**  Rendering Technique is in use, reflections on non-mirror surfaces are modeled, as well. See [Physically Based \(Ray Trace\) on page 1151](#).

Reflections in Mirrors can be toggled on or off in a camera view by selecting **3D> Camera View Options> Toggle Reflections**  as well as in the Camera Specification dialog.

 GPU Ray Tracing in Physically Based renderings is capable of more extensive reflection effects. When GPU Ray Tracing is enabled, Reflections should be toggled on for best quality. See *GPU Ray Tracing on page 1132*, above.

## MATERIAL DEFINITIONS

Textures are graphic files that represent contoured surfaces of objects such as carpet, bricks, tile, and wood in rendered views. Textures are assigned to materials which in turn are assigned to objects. See *Patterns and Textures on page 1050*.

The display of materials in rendered views is controlled by settings on the TEXTURE and PROPERTIES panels of the Define Material dialog. See *Define Material Dialog on page 1066*.

For realistic rendered views, it is sometimes helpful to make adjustments to texture properties so that they map to surfaces correctly. See *Mapping Patterns and Textures on page 1062*.

Brightness, shininess and transparency control how light sources affect the display of surfaces in rendered views. See *Lighting on page 1135*.

If no texture is selected for a material or if the display of textures is turned off, affected surfaces are a solid color instead.

Specially produced material map image files can add realism to a material's appearance in rendered and CPU Ray Trace views by making it appear contoured instead of flat or glossy instead of rough. See *Material Maps on page 1050*.

## IMAGES

Image objects use picture files to represent individual objects such as trees, flowers, and vehicles in 3D views and exported VRML files. Images are useful because they have only one 3D surface, allowing them to represent complicated 3D objects with a high degree of realism but with minimal cost in terms of performance. See *Placing Images on page 1185*.

## BACKDROPS AND GENERATED SKY

A backdrop is an image, usually of an exterior view, that displays in the background of 3D views to help place the model into a realistic setting and add a sense of perspective. If a backdrop is not specified, Chief Architect applies a background color. See *3D Backdrops on page 1204*.

The Generated Sky is a spherical backdrop option that simulates the sky at different times of day based on the position of the Generic Sun. A horizon line is also modeled when the Generated Sky is in use. In a camera with a Tilt Angle of 0°, the horizon line runs across the center of the view window. As the sun is moved closer to the horizon, its intensity decreases and its color becomes an increasingly deep amber color. When the sun is moved below the horizon it may continue to contribute to light to the sky, but it will not cast light on the model. When the sun is either below the horizon or toggled off, representations of the moon and stars become visible. See *Sunlight and Moonlight on page 1136*.

Backdrops and the Generated Sky are view specific and can be set in the Camera Specification dialog. See *Backdrop Panel on page 1122*.

## EDGE SMOOTHING

 Angled surface edges and pattern lines will sometimes display on screen as jagged or stair-stepped. Edge Smoothing softens this effect, producing cleaner looking lines.

You can specify how much Hardware Edge Smoothing occurs in 3D views in the Preferences dialog. Hardware Edge Smoothing is set to "High" by default. Using a lower setting will lower rendering quality but may improve performance on some systems. See *Render Panel on page 124*.

Even higher quality Edge Smoothing can be produced by checking **Edge Smoothing When Idle** in the Camera Specification dialog. This setting does not affect a camera while its position or orientation are being changed, but applies additional smoothing to edge and pattern lines when the camera is not in motion. See [Camera Panel on page 1117](#).

This high quality Edge Smoothing option is view-specific and can also be toggled on or off by selecting **3D> Camera View Options> Toggle Edge Smoothing When Idle** .

## HIDE CAMERA-FACING EXTERIOR WALLS

 Occasionally, it can be very helpful to view the interior of a structure from an exterior view. To achieve this, create an exterior camera view or overview and select **3D> Camera View Options> Hide Camera-Facing Exterior Walls**. This option is view-specific and can also be set in the Camera Specification dialog. See [Camera Panel on page 1117](#).

Hide Camera-Facing Exterior Walls is also an option for Walkthrough Paths. See [Record Walkthrough Options Dialog on page 1216](#).

When Hide Camera-Facing Exterior Walls is enabled in a camera view, the **CPU Ray Trace**  tool will not be available.

## MATERIAL TRANSPARENCY

Most materials are opaque while some materials, such as glass, are partially transparent. Transparency can be set in the Define Material dialog. See [Properties Panel on page 1072](#).

There are two ways to specify a material as transparent:

- For General materials, the **Transparency** setting controls how opaque or transparent a material is and can be set along with other properties like Roughness.
- Transparent materials are instead completely transparent but have an **Index of Refraction** setting that controls how much light bends when it passes through the material in GPU and CPU Ray Trace views.

Transparency is supported in all Rendering Techniques. Most Rendering Techniques, however, have an **Opaque Window Glass** setting that, when checked, overrides the transparency of the Glass components of exterior doors, exterior windows, and interior windows. Interior doors with Glass components are unaffected. When this box is checked, Glass components display the Material Color assigned to their material. See [Rendering Technique Options on page 1153](#).

---

# Lighting

Lighting controls the visibility of objects in 3D views, affects the appearance of surfaces, and influences the appearances of colors and textures on those surfaces.

Each individual light source has a set of properties, such as intensity and color, that can be defined. See [Light Data Panel on page 675](#).

By default, a maximum of eight lights can display in a given camera view or overview. If more than eight are present, those with the highest intensity located in the same room as the camera are rendered. Lights in adjacent rooms may also be rendered, with the highest intensity lights rendered first.

- You can specify a different Maximum Lights number in the Camera Specification dialog. See [Camera Panel on page 1117](#).
- You can also manually turn on and off individual lights in order to get the desired lighting effects. See [Displaying Lights on page 1138](#).
- In addition, you can create custom Light Sets with specific lights turned on or off as needed for specific purposes. See [Light Sets on page 1139](#).

When the camera is outside a building, the program normally uses sunlight for lighting calculations and turns off all other light sources. You can turn the sunlight off and use all the other exterior lights to simulate nighttime views.

There are five types of light sources in Standard rendered and CPU Ray Trace views:

## DEFAULT INTERIOR LIGHTS

If you create a Standard interior camera in a room where no lights have been placed, the program creates a Default Light source within that room. The Default interior light acts like a central point light source but cannot be selected or edited.

Because the Default Light cannot be adjusted, if you want to control the light in an interior rendered view, you must add lights to the rooms in your plan by placing light fixtures and Added Lights.

## LIGHT FIXTURES

An electric symbol that represents a Light Fixture can have one or more light sources associated with it. Properties for each light source such as light type, color, and intensity can be modified in the fixture's specification dialog. See [Light Data Panel on page 675](#).

If the light source is a Point or Spot Light, you can also adjust its Offset, or position relative to the fixture. If you choose to **Show Position in Camera View**, you can see where the light source is located.

Light sources look most realistic when they are offset from a surface.

## ADDED LIGHTS



In plan view, select **3D> Lighting> Add Lights** to quickly add a light source to a plan. Added Lights and their labels are placed on the "Light Sources" and "Light Sources, Labels" layers by default.

Added lights only act as light sources in plan files that have at least one room defined. They display 2D symbols in plan view but do not display as objects in 3D views.

While Added Lights do not display as objects in 3D, you can specify that an Added Light's position be represented by red crosshairs in rendered views that use lighting. Spot Lights also display a blue arrow indicating the light's direction. See [Light Data Panel on page 675](#).

Added lights can be placed into objects that normally do not generate light, such as a TV.

There are two types of added light sources: Point Lights and Spot Lights. See [Light Types on page 1137](#).

## SUNLIGHT AND MOONLIGHT

Sunlight is the only source of light in exterior daytime camera views. When standard shadows are enabled, sunlight can also shine through windows into interior rooms. See [Shadows on page 1133](#).

Select **3D> Lighting> Toggle Sunlight**  while in a camera view to simulate either daytime or nighttime exterior lighting.

There are two types of sunlight:

- The Generic Sun's default intensity, color, and angle can be set in the Generic Sun Defaults dialog, and can be modified in the Adjust Sunlight dialog. In addition, you can specify that it follow the camera in 3D views so surfaces are always illuminated. The Generic Sun's settings are view specific: each 3D view can have its own, unique settings. See [Adjust Sunlight Dialog on page 1148](#).



- You can instead place a **Sun Angle**  in plan view to produce sunlight based on specific date, time, latitude, and longitude information. See *Sun Angles and Shadows on page 1143*.

You can specify that a particular Sun Angle or the Generic Sun be used in any active camera view in the Adjust Sunlight dialog. See *Adjust Sunlight Dialog on page 1148*.



 Select **3D> Lighting> Move Sun**, then click and drag in any direction in a camera view to adjust the position of the Generic Sun. You can also Ctrl + click (Command + click in macOS™) to place the Generic Sun at the location where you click. This tool is only available in Rendering Techniques that support lighting, or any camera view using the Generic Sky backdrop. This option is most effectively used when **Use Generated Sky** is in use and cannot be used while Sun Follows Camera is checked in the Adjust Lights dialog.

 When the Generated Sky is in use and the Generic Sun is either toggled off or has been moved below the horizon, representations of the moon and stars can be seen in the sky. Select **3D> Lighting> Move Moon**, then click and drag in any direction or Ctrl + click to adjust the position of the moon. This tool is only available in Perspective Views. The intensity and other attributes of the moon and stars can be set in the Camera Specification dialog when **Use Generated Sky** is checked. See *Backdrop Panel on page 1122*.

## AMBIENT LIGHTING AND OCCLUSION

Ambient lighting simulates the way light bounces around a scene, producing a basic level of uniform illumination on all surfaces. It is used in camera views and overviews using the Standard, Duotone, and Watercolor Rendering Techniques and in ray trace views.

There are three types of ambient light in Chief Architect:

- **Interior Ambient** controls the ambient light in interior views.
- **Daytime Ambient** controls the ambient light in exterior views when **Toggle Sunlight**  is on. See *Sun Angles and Shadows on page 1143*.
- **Nighttime Ambient** controls the ambient light in exterior rendered views when **Toggle Sunlight**  is off.

You can control the brightness of each in the Rendering Technique Options dialog. See *Standard Panel on page 1154*.

Ambient occlusion adds shading to surfaces near corners which, because of their location, reflect less light compared to other surfaces. Too little ambient occlusion can result in a view having a flat appearance. You can specify the amount of **Ambient Occlusion** to use in Standard, Duotone, Watercolor, and Physically Based renderings in the Camera Specification dialogs. See *Camera Panel on page 1117*.

Additional ambient occlusion options are available in ray trace views. See *Lighting Panel on page 1172*.

Ambient occlusion maps add the appearance of depth to materials by indicating which parts a texture receives more ambient light and which parts receive less. See *Material Maps on page 1050*.

---

## Light Types

There are two types of light source, each of which generates light in a different way and allows you to create a variety of lighting effects:

- Point Light sources
- Spot Light sources

Any light source except a Sun Angle can be specified as a Point or Spot Light in the Electrical Service Specification dialog. See *Light Data Panel on page 675*.

 In addition to being assigned to light fixtures, these two types of light sources can be placed in a plan as **Added Lights**, which are light sources that are not associated with a fixture. As with light fixtures, the lighting properties of Added Lights can be specified in their specification dialog. See [Light Specification Dialog on page 1142](#).

## POINT LIGHTS

Like a bare light bulb, a Point Light radiates light equally in all directions from its origin. Point lights are a realistic representation of non-directional electric lighting.

If no user defined light exists, Chief Architect creates a Point Light source to represent a light within a room.

### *To create a Point Light source*

1. In plan view, select **3D> Lighting> Add Lights** .
2. Click in plan view. Do not drag the pointer when you click the screen, or you will create a Spot Light.

## SPOT LIGHTS

A Spot Light focuses the light in a specified direction. The Tilt and Direction Angles can be specified in a Spot Light's specification dialog.

### *To create a Spot Light source*

1. In plan view, select **3D> Lighting> Add Lights** .
2. Click and drag in plan view no more than two plan feet (600 mm) in any direction.
3. As you drag, the light preview will look like a Spot Light icon.
4. When you release the mouse, a Spot Light pointing in the direction that you dragged is created.

You can also use a Spot Light's edit handles in plan view to move it, as well as change its direction and Cut Off Angle.

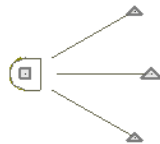

---

## Displaying Lights

 The display of light fixtures and Added Lights in floor plan and 3D views is controlled in the Layer Display Options dialog. Light fixtures are placed on the "Electrical" layer by default, and Added Lights, on the "Light Sources" layer. See [Layer Display Options Dialog on page 179](#).

In addition, they can serve as sources of light in rendered and/or CPU Ray Trace 3D views. They can be turned on and off, as well as set to cast shadows.

### IN PLAN VIEW



In plan view, both light fixtures and Added Lights can display labels when the "Electrical, Labels" and/or "Light Sources, Labels" layers are turned on. See [Label Panel on page 700](#).

## IN 3D VIEWS

Light fixtures and Added Lights can serve as sources of light in rendered and/or CPU Ray Trace views.

### *To turn a light on or off*

There are several ways to turn a light fixture or Added Light on or off:

- Select one or more fixtures or Added Lights and click the **Turn Light(s) Off in 3D**  or **Turn Light(s) On in 3D**  edit button.
- Uncheck **On** in the object's specification dialog. See *Light Data Panel on page 675*.
- Clear the **On/Off** check box in the Adjust Lights dialog. See *Adjust Lights Dialog on page 1140*.

Added Lights are not associated with a 3D fixture, but you can specify that any light source's location be represented in 3D views using crosshairs. Position Indicators can display in all Rendering Techniques aside from Hand Drawn Lines. See *Light Data Panel on page 675*.

Light source position indicators will only display when the light is in use in the current 3D view. That is, it must be:

- Turned on.
- Specified for use in Camera views.
- In-use in the current view.
- Either located in a room or in an exterior view with Sunlight toggled off.

Sunlight will shine through windows into interior rooms when shadows are enabled. See *Shadows on page 1133*.

---

## Light Sets

By default, cameras use an Automatic Lighting Mode that allows a set number of lights to illuminate the view. This number can be specified in the Camera Specification and Adjust Lights dialogs. See *Camera Panel on page 1117*.

If more than the set number of lights are present, lights are prioritized in this order:

- Lights in the same room as the camera before those in different rooms.
- Higher intensity lights before lower intensity lights.
- Lights closer to the camera before those further away.

Regardless of their intensity or proximity to the camera:

- Interior lights are not used in exterior camera views.
- Exterior lights are not used in exterior camera views when the Sunlight is toggled on. See *Sunlight and Moonlight on page 1136*.
- Lights on floors above the camera are not used in Floor Overviews. See *3D View Tools on page 1084*.

Light Sets are an alternative to this automatic behavior. When a Light Set is specified, you control which lights are in use in the current camera and which are not, regardless of their distance from the camera. Multiple Light Sets can be created for different purposes in a single plan, including CPU ray tracing. See *Lighting on page 1181*.

The Automatic Lighting Mode is useful because it is an easy way to produce reasonable lighting without taxing your video memory. Light Sets can take some time to set up and may require more resources on your system; however, they give you greater control when producing presentation views.

Light Sets are not removed when lights are deleted from a plan. They are removed, however, when objects are purged using the **Save as Template**  tool. See *Save as Template on page 89*.

## ADJUST LIGHTS DIALOG

 Light fixtures and Added Lights in the current plan are listed and can be edited in the Adjust Lights dialog. Select **3D> Lighting> Adjust Lights** to open this dialog in floor plan or any 3D view. You can also open it by clicking the **Adjust Lights** button in the Camera Specification dialog. See *Camera Panel on page 1117*.

The Adjust Lights dialog is an efficient way to control which lights are turned on in 3D views.

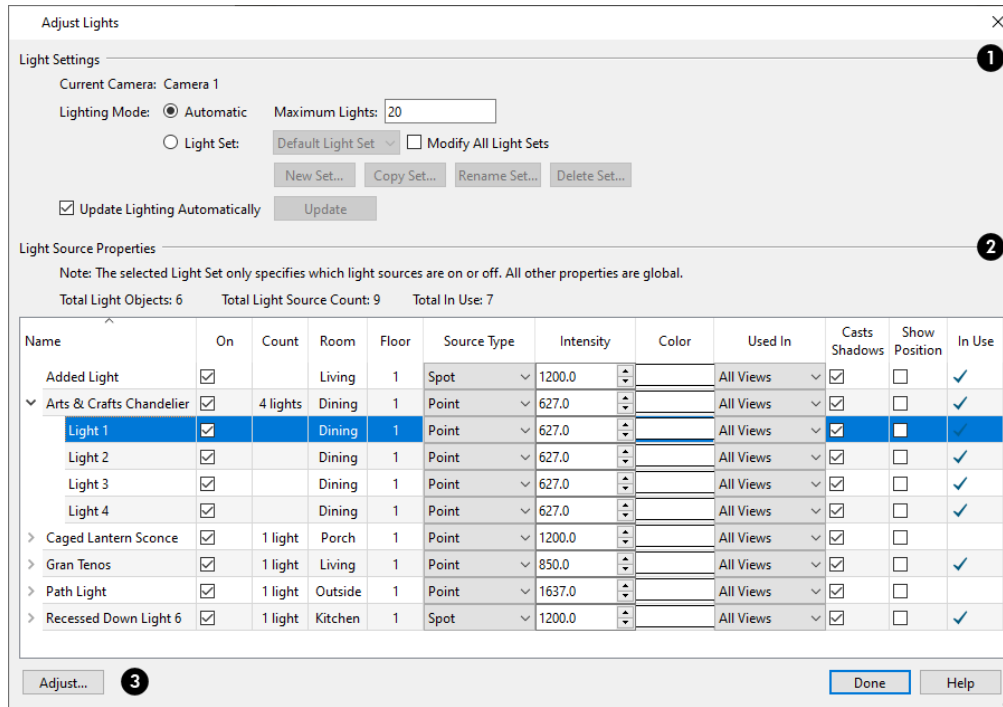

### 1 Light Settings

The settings at the top of the dialog allow you to manage the Light Settings in the current plan. When the dialog is opened while a camera view is active, these settings are available:

- The name of the **Current Camera** is stated here for reference.
- Specify the desired **Lighting Mode**. **Automatic** uses the specified **Maximum Lights** while **Light Set** uses the lights as specified below.

When **Light Set** is selected, several additional settings are available:

- Select a **Light Set** to edit from the drop-down list. If the dialog is opened from a camera view, this Light Set will become active.
- Check **Modify All Light Sets** to apply any changes made to the properties of the selected Light Sets to all Light Sets.
- Click the **New Set** button to create a new Light Set with all light sources turned off.
- Click the **Copy Set** button to create a new Light Set that is an exact copy of the one that is currently selected.
- Click the **Rename Set** button to type a new name for the selected Light Set. Not available for the Default Set.

- Click the **Delete Set** button to delete the selected Light Set. A Light Set can only be deleted if it is not in use, and only if the Adjust Lights dialog is opened from the menu in plan view. Not available for the Default Set.

In some circumstances, performance in the Adjust Lights dialog can be slow when opened from a camera view.

- To avoid this, uncheck **Update Lighting Automatically**.
- When Update Lighting Automatically is checked, you can click the **Update** button to update the lights in the camera view.

## 2 Light Source Properties

All lights in the current plan are listed here, and a variety of their attributes can be edited; however, only the On setting is specific to the selected Light Set. The others are global.

Note: If a light fixture is assigned to a Distribution Path or Region, it will only be listed once in the Adjust Lights dialog. See *Distributed Objects on page 1042*.

- Total Light Objects, Light Sources, and In Use lights are reported for reference.
- All lights in the current plan are listed in the table using the same **Names** as their labels.
- If a line item is a light fixture, it will have an arrow to the left of its name. Click this arrow to show the fixture's light sources as individual line items.
- Check the box in the **On** column to turn it on or uncheck the box to turn it off. If a fixture has multiple light sources and only some are on, a solid square will display in its check box.
- The **Count** column lists the number of light sources assigned to each light fixture. This column is empty for Added Lights.
- The **Room** column states the location of each light. If a light is not in a room, "Outside" will be reported.
- The **Floor** column states the floor level that each light is on.
- The **Type** column states the type of light source used by each light. See *Light Types on page 1137*.
- The **Intensity** column states the strength of each light.
- The **Color** column displays the light's color. Click the button to choose a different color if you wish.
- The **Used In** column states which types of views each light is used in: camera views only, CPU Ray Trace views only, or both.
- The **Show Position** column indicates whether each light source's position is set to show in camera views. See *In 3D Views on page 1139*.
- The **In Use** column states whether each light is emitting light in the Current Camera view. If a fixture has multiple light sources and only some are in use, a blue box will display in its row.

## 3 Adjust

To adjust the properties of a light in the list, double-click on its name or select it and click the **Adjust** button. Make changes to the light in its specification dialog and click OK. For more information, see *Light Specification Dialog on page 1142* or *Light Data Panel on page 675*.

Multiple lights can be selected by holding down the Shift key. If multiple lights are selected, clicking the Adjust button opens the Light Data dialog, which is similar to the LIGHT DATA panel of a single object's specification dialog. This dialog will also open if a Tray Ceiling Polyline is the selected light source.

If you are in a 3D view that displays lighting, the view will regenerate based on the new light settings.

The Generic Sun and Sun Angles are not listed in this dialog. See [Sunlight and Moonlight on page 1136](#).

---

## Light Specification Dialog

Select one or more Point or Spot Lights and click the **Open Object** edit button to open the Light Specification dialog.

You can also select **3D> Lighting> Adjust Lights**  to access a list of the light sources present in the current plan and open the specification dialog for any of them. See [Adjust Lights Dialog on page 1140](#).

### LOCATION PANEL

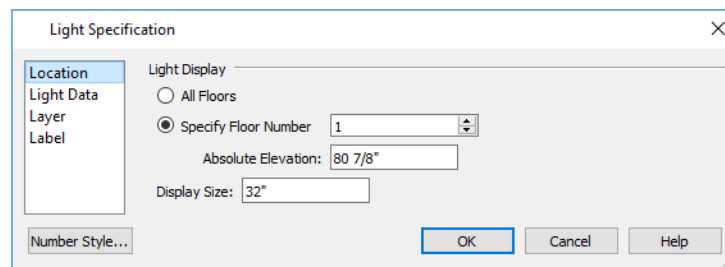

### Light Display

Specify where the selected Added Light displays in plan and 3D views.

- Select **All Floors** to display the selected light on all floors in plan view. See [Multiple Floors on page 730](#).
- Select **Specify Floor Number** to display the light on one floor only, then choose a floor number from the drop-down list.

Note: The floor or floors that an Added Light displays on in plan view is totally independent of where it displays in 3D.

- Specify the selected light's **Absolute Elevation**, measured relative to 0, which is the default height of Floor 1.
- Specify the **Display Size**, which is the diameter of the circle representing the Added Light in plan view.

### LIGHT DATA PANEL

The settings on this panel are also found on the same panel of the Electrical Service Specification dialog. See [Light Data Panel on page 675](#).

Depending on the type of light(s) selected, the options available here may vary.

### LAYER PANEL

For information about the settings on this panel, see [Layer Panel on page 186](#).

### LABEL PANEL

Labels for Added Lights display in plan view when the “Light Sources, Labels” layer is turned on and use the Text Style assigned to that layer. See [Text Styles on page 538](#).

For information about the settings on this panel, see [Label Panel on page 700](#).

---

## Sun Angles and Shadows

In addition to the functional and aesthetic properties of ambient light and light sources in rendered views, the direction and angle of the sun's light and shadows are an important consideration. Two tools allow you to generate sunlight and sun shadows with accuracy:



**North Pointers** allow you to specify the direction of true north in a plan.



**Sun Angles** let you specify an exact location, date, and time for sunlight and sun shadow generation.

### NORTH POINTER

The North Pointer tool is used to define the direction of true north in a plan. The direction of north does not affect the orientation of the Snap and Reference grids, but it does affect the direction of sunlight and sun shadows, how conditioned area totals are calculated, and how bearing information is interpreted by the program.

 Every bearing is defined relative to North, so it is best to establish this direction before entering survey information for a site plan.

If a North Pointer is not used, north is assumed to be straight up on screen in plan view.

Select **CAD> North Pointer** , then click and drag to draw the pointer, starting at the tail and dragging toward the point.

Once it is drawn, you can define its exact length and angle in its specification dialog. See [Line Specification Dialog on page 304](#).

Multiple North Pointers can be drawn in a given plan file, and will always point in the same direction automatically. If you rotate one of them, the others will automatically rotate to match. Similarly, if you draw a new North Pointer at a different angle, existing North Pointers will rotate to that angle automatically.

If you choose to display line angles when a North Pointer exists, be sure to select the appropriate format in the CAD Defaults dialog. See [CAD Defaults and Preferences on page 291](#).

- If angles are set to **Bearings**, they are relative to the North Pointer.

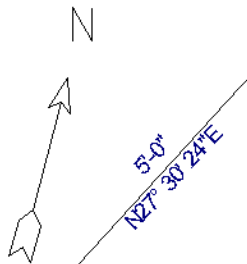

- If angles are set to show as **Degrees**, the angle relates to 0° (horizontal to the right) even if a North Pointer is present.

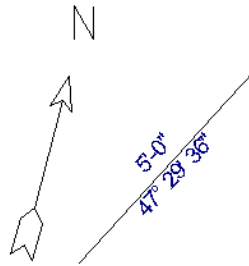

A North Pointer can be selected and edited using its edit handles and Edit Toolbar buttons. All attributes of the N aside from its size are drawn from the Text Style assigned to the layer it is are placed on. For more information, see [Editing Line-Based Objects on page 216](#).

## SUN ANGLES

Sun Angles let you establish exactly where your plan's building site is located, and a precise date and time. This information allows the program to determine the sun's location in the sky and generate sunlight and sun shadows with accuracy.

Note: Sun Angle calculations do not adjust for elevation. They are based on formulas published by the United States Naval Observatory and have limited accuracy as documented by the USNO.

When an exterior 3D view is rendered, the program looks for an active Sun Angle. If it finds none, the Generic Sun is used. See [Sunlight and Moonlight on page 1136](#).

### *To create a Sun Angle*

1. In plan view, go to Floor 1 or Floor 0. Sun Angles can only be created on these floor levels. See [Multiple Floors on page 730](#).
2. Select **CAD> Sun Angle**  and click in the drawing area to place a Sun Angle arrow at that location.
3. In the Sun Angle Specification dialog, specify the Sun Angle's Earth Data and other information. See [Sun Angle Specification Dialog on page 1145](#).
4. After it is created, a Sun Angle cannot be rotated; but it can be moved as well as resized using its edit handles. Shadows are not affected.

Multiple Sun Angles can be created, each with different specifications; however, only one can be used as a light source in a given 3D view. If more than one Sun Angle is present, specify the one to use in the current view in the Adjust Sunlight dialog. See [Adjust Sunlight Dialog on page 1148](#).

Sun Angles can display their date and time in plan view and can also produce sun shadow polylines in plan view. Both Sun Angles and their shadows are on the "Sun Angles & Shadows" layer by default.

## SUN SHADOWS

Sun Angles allow the program to produce shadows cast by a building that reflect the exact position of the sun in the sky in a particular location and at a specific date and time. This position and time information is specified in the Sun Angle Specification dialog; the date format is derived from your operating system settings. See [Earth Data Panel on page 1146](#) and [Region and Language Settings on page 78](#).

In plan view, sun shadows are represented by polylines filled with a hatch pattern. If a Terrain Perimeter is present, the shape of a sun shadow polyline is affected by changes in terrain height. If no Terrain Perimeter exists, sun shadows fall on



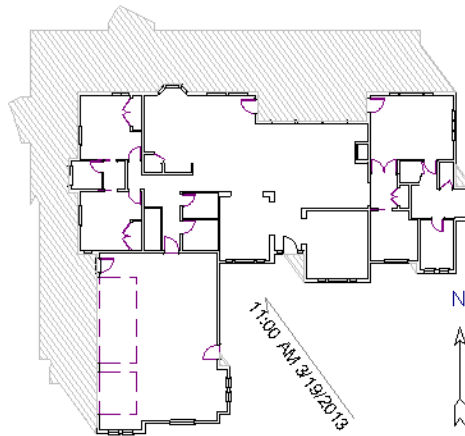

an imaginary plane at a height of zero, the default height for Floor 1. Sun shadows rebuild whenever the terrain is rebuilt. See [Build Terrain on page 1245](#).



No sun shadow generates if the sun is below the horizon or if it is so low on the horizon that the shadow would be extremely long.

Multiple Sun Angles can be placed in the same plan to allow the simultaneous display of shadows cast at different times in plan view. Only one should be turned on in 3D views at any given time, however.

	Specify different line colors and/or styles for shadows cast by multiple Sun Angles on the Line Style and Fill Style panels of the Sun Angle Specification dialog.
--	--

To generate the sun shadows associated with a particular Sun Angle, select it and click the **Make Shadow**  edit button or click the **Make Shadow** button in the Sun Angle Specification dialog. See [Lighting Data Panel on page 1147](#).

There are several ways to delete a sun shadow polyline:

- In plan view, select and delete the defining polyline.
- In plan view, select and delete the Sun Angle arrow.
- In plan view, select the Sun Angle arrow and click the **Delete Shadow**  edit button.
- In the Sun Angle Specification dialog, click the **Delete Shadow** button. See [Earth Data Panel on page 1146](#).
- In the Sun Angle Specification dialog, click the **Make Shadow** button to delete existing shadows and create new ones.

---

## Sun Angle Specification Dialog

 Select **CAD> Sun Angle**, then click in plan view to open the Sun Angle Specification dialog and create a new Sun Angle. See [Sun Angles and Shadows on page 1143](#).

To open the Sun Angle Specification dialog for an existing Sun Angle, select it and click the **Open Object**  edit button.

This dialog can also be accessed by clicking the **Edit** button in Adjust Sunlight dialog. See [Adjust Sunlight Dialog on page 1148](#).

## EARTH DATA PANEL

The settings on the EARTH DATA panel let you establish exactly where your plan's building site is located, and exactly when the sun's light should be calculated. This information allows the program to generate sunlight and sun shadows with accuracy.

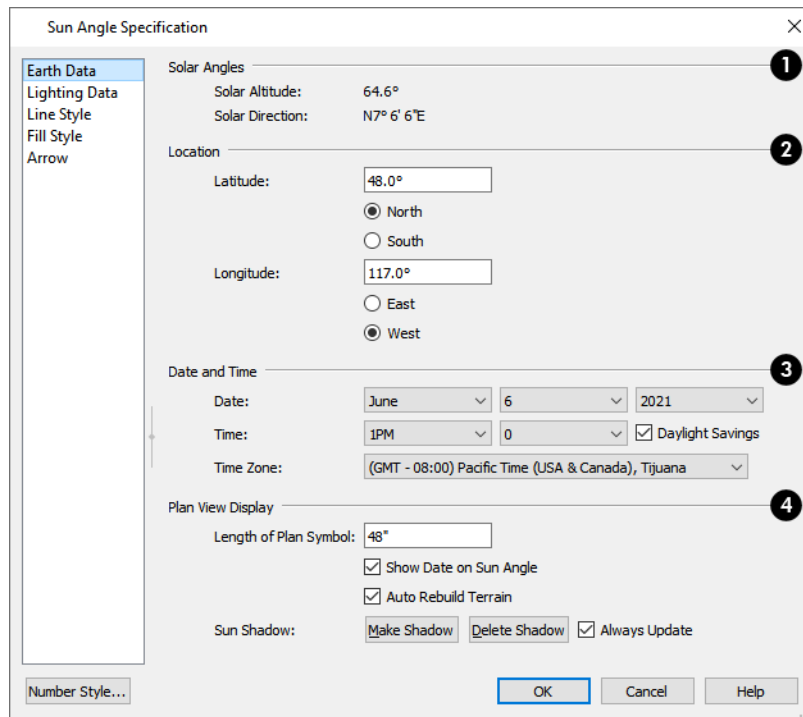

### 1 Solar Angles

The Solar Angles display for reference and may update as changes are made to the settings on this panel.

- The **Solar Altitude** is the angle of the sun above the horizontal plane, in degrees.
- The **Solar Direction** is the angle between true North and the sun's direction. This is the angle the Sun Angle arrow points in plan view relative to the direction of North. See *North Pointer on page 1143*.

### 2 Location

Specify the Location of the selected Sun Angle. The initial location can be set in the Preferences dialog. See *CAD Panel on page 114*.

- Specify the **Latitude**, which is measured either **North** or **South** of the equator, depending on which radio button you select.
- Specify the **Longitude**, which is measured either **East** or **West** of the Greenwich meridian, depending on which radio button you select.

### 3 Date and Time

Specify the Date and Time of the selected Sun Angle. The initial time zone can be set in the Preferences dialog.

- Specify a **Date** for the selected Sun Angle. Select a month from the first drop-down list, a day from the second, and a year from the third.

- Specify a **Time** for the selected Sun Angle. Select an hour from the first drop-down list; minutes in 15 minute increments can be selected from the second list.
- If you want the Sun Angle to observe **Daylight Savings Time**, check this box.
- Specify the **Time Zone** that the building site is located in.

#### 4 Plan View Display

- Specify the **Length of Plan Symbol**, which is the length of the Sun Angle arrow in plan view.
- Check **Show Date on Sun Angle** to have the date and time display on the Sun Angle arrow in plan view. This label uses the Text Style assigned to the “Sun Angle & Shadows” layer. See *Text Styles on page 538*.
- Check **Auto Rebuild Terrain** to rebuild the terrain automatically whenever you create a sun shadow. If this is unchecked and you regenerate sun shadows, the program will prompt you to rebuild the terrain. >See *Building the Terrain on page 1256*.

When you use the Build Terrain command in plan view, all sun shadows in the plan are automatically updated.

- Click the **Make Shadow** button to create or regenerate the sun shadow in plan view. See *Sun Shadows on page 1144*.
- Click the **Delete Shadow** button to remove the sun shadow from plan view.
- Check **Always Update** to have the program update the selected Sun Angle’s shadow whenever any of the defining information is changed. When this is checked, the program may be slower when changes are made in this dialog.
- If Always Update is unchecked and you make changes in this dialog, click the **Make Shadow** button to generate a new shadow.

Note: The Make Shadow option does not toggle Shadows, but may cause 3D views to update if they are using the selected Sun Angle. See *Shadows on page 1133*.

### LIGHTING DATA PANEL

A Sun Angle can be used as a light source in 3D views. The settings on the LIGHTING DATA panel control attributes of the sunlight associated with the selected Sun Angle.

The settings defined on the LIGHTING DATA panel do not affect the sun shadow in plan view: they only affect 3D views in which lighting and shadows can display.

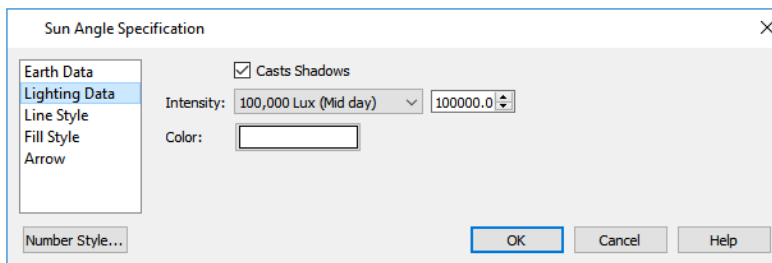

- When **Casts Shadows** is checked, the light source associated with the selected Sun Angle casts shadows. These shadows are similar to the shadow shown in plan view, but may render differently based on the presence of other light sources. See *Shadows on page 1133*.

- Select an **Intensity** from the drop-down list or specify a value using the text field to define the relative strength of the light source. The time of day as set on the EARTH DATA panel does not affect how the Sun Angle renders as a light source, but this does.
- Click the **Color** bar to select a color for the sunlight associated with the selected Sun Angle. See *Color Chooser/Select Color Dialog on page 203*.

## LINE STYLE PANEL

For information about the LINE STYLE panel, see *Line Style Panel on page 305*.

## FILL STYLE PANEL

The settings on the FILL STYLE panel control the appearance of the selected Sun Angle's shadow in plan view. For information about these settings, see *Fill Style Panel and Dialogs on page 193*.

## ARROW PANEL

For information about the settings on the ARROW panel, see *Arrowheads on page 327*.

---

# Adjust Sunlight Dialog





The Adjust Sunlight dialog allows you to control the intensity, direction and color of the Generic Sun light source in the currently active 3D view or to select a Sun Angle to serve as the source of sunlight in the currently active view. See *Sunlight and Moonlight on page 1136*.

The settings in this dialog are view specific. Any changes made to them affect the sun in the currently active 3D view only. Other 3D views can have their own unique settings.

The initial sunlight attributes used in a newly created camera are set in the Sunlight Defaults dialog. See *3D View Defaults and Preferences on page 1080*.

There are four ways to open the Adjust Sunlight dialog:

- Click the **Adjust Sunlight** button in the Camera and Cross Section/Elevation Specification dialogs. See *Camera Panel on page 1117*.
- From the menu, select **3D> Lighting> Adjust Sunlight**.
- From the toolbar, click **Camera View Lighting Tools** , then click the **Adjust Sunlight**  button.
- Right-click in an empty space in the background area, then select **Adjust Sunlight** from the contextual menu.

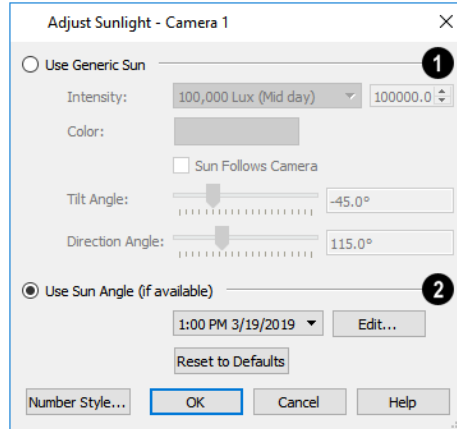

## 1 Use Generic Sun

Select Use Generic Sun to represent the sun in the currently active 3D view using the settings that follow.

- Use the **Intensity** slider bar or text field to control the brightness of the Generic Sun's light. This setting is not applied in views using the Generated Sky. See [Backdrops and Generated Sky on page 1134](#).
- Click the **Color** bar to define the color of the light being modeled. Colored sunlight may be used to achieve special lighting effects, but may alter the appearance of your material colors and textures. The color selected here is not used in views using the Generated Sky.
- Check **Sun Follows Camera** to adjust the position of the Generic Sun so that it is always behind the camera, illuminating surfaces in the view. When this is checked, the Tilt and Direction Angle settings that follow are disabled. This option must be unchecked in order to use the Move Sun and Move Moon tools. See [Sunlight and Moonlight on page 1136](#).

Note: If the Generated Sky is used in the current view and Sun Follows Camera is checked, the Generated Sky will not update if the camera is moved.

- Specify the **Tilt Angle**, which is the angle of the sunlight with respect to the horizon. A value of 90° means that the light points straight up, while a value of -90° means that the light points straight down. 0° is parallel to the horizon.
- Specify the **Direction Angle**, which is the direction that the sunlight points toward. 0° is measured horizontally on screen, pointing to the right. Positive values rotate in a counter-clockwise direction from there, while negative values rotate clockwise.
- Click the **Reset to Defaults** button to restore the settings set in the Sunlight Defaults dialog in the current view.
- In the Sunlight Defaults dialog, the **Restore Initial Settings** button is available instead. Click this to reset the options in that dialog to the originally installed settings.

## 2 Use Sun Angle

Select Use Sun Angle to represent the sun using a light source defined by a **Sun Angle** . See [Sun Angles and Shadows on page 1143](#).

- Select a Sun Angle from the drop-down list to serve as the source of sunlight in the currently active 3D view. If no Sun Angle is present, the Generic Sun is used.

- Click the **Edit** button to open the Sun Angle Specification dialog for the selected Sun Angle.

By default, the Generic Sun light color is pure white, which has the least effect on the appearance of material colors and textures. See [Materials on page 1049](#).

---

## Rendering Techniques

 Any camera view, cross section/elevation view, or overview can be generated using a variety of Rendering Techniques to produce views for a range of different purposes: from detail drawings to artistic presentation views. To access these tools, while a 3D view is active, select **3D> Rendering Techniques**, then select one of the following techniques:

There are two ways to create a view using a particular Rendering Technique:

- Create a 3D view, then select the desired rendering technique from the menu.
- Select the desired rendering technique in the Camera Defaults dialog, then create a 3D view. See [Camera Defaults Dialogs on page 1081](#).

Once a view is created, the effects of the selected rendering technique can be adjusted in the Rendering Technique Options dialog. See [Rendering Technique Options on page 1153](#).

If a camera view is saved, its Rendering Technique settings are saved, as well. See [Saving and Printing 3D Views on page 1115](#).

You can specify which Rendering Techniques use a backdrop image. See [3D Backdrops on page 1204](#).

 The Watercolor and Hand Drawn Lines techniques require more time to generate than other Rendering Techniques. To save time, adjust the camera's perspective before using one of these techniques. See [Editing 3D Views on page 1105](#).

### STANDARD RENDERING

 Standard rendering is a photo-realistic technique that represents materials using textures, models lighting and shadows, and can also display reflections. Surface edge lines are not drawn and no special colors or effects are applied; however, when Hand Drawn Lines on Top is enabled, pattern lines are used.



In plan view, the camera symbol for a view using the Standard technique displays an S in its center. See [Displaying 3D Views on page 1097](#).

### VECTOR VIEW

 In Vector Views, surface edge lines are drawn and pattern lines and colors are used to represent materials while textures are not. Shadows are supported, and when in use a single light source is used to produce them. Shading

Contrast can be applied to surfaces, but other special colors or effects are not.

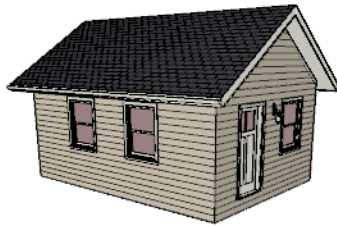

In plan view, the camera symbol for a view using the Vector View technique displays a V in its center.

### PHYSICALLY BASED (RAY TRACE)

 Physically Based rendering is similar to the photo-realistic Standard technique: it represents materials using textures, does not draw surface edge lines, models lighting, and can display shadows. When Hand Drawn Lines on Top is enabled, pattern lines are also used.

Physically Based rendering models material properties and light propagation more accurately than other rendering techniques and is best used when a focus on lighting and finish materials is the goal. On systems that support it, real-time GPU Ray Tracing is performed in Physically Based renderings. See [GPU Ray Tracing on page 1132](#).

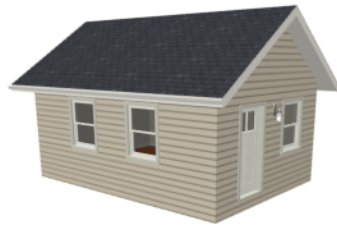

In plan view, the camera symbol for a view using the Physically Based technique displays a Ph in its center.

### CLAY

 Clay renderings emphasize the shapes and proportions of objects in the model rather than the materials on their surfaces. Surfaces are rendered using a single solid color or a palette of colors of your choosing, and Ambient Occlusion and Metal maps are included for any materials that have them. When Hand Drawn Lines on Top is enabled, pattern lines are also used. Lighting and shadows are modeled, and on systems that support it, real-time GPU Ray Tracing is an option. See [GPU Ray Tracing on page 1132](#).



In plan view, the camera symbol for a view using the Clay technique displays an C in its center.

## GLASS HOUSE

 Glass House rendering uses different shades of a single color to display the model with surface edge lines and semi-transparent surfaces. Lighting and shadows are not modeled, and materials are not represented, so neither pattern lines nor textures are used.

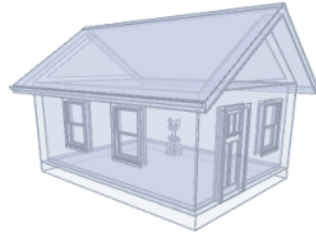

In plan view, the camera symbol for a view using the Glass House technique displays a G in its center.

## TECHNICAL ILLUSTRATION

 Technical Illustration rendering draws surface edge and pattern lines, and uses shades of two colors, Warm and Cool. The warm shade is applied to surfaces that face the light source in the view, and the cool shade, to surfaces that face away from it.

Only one light source is used: the light with the highest Intensity found in the room containing the camera. In exterior views, this light is always the Generic Sun. If no lights are on, a fallback light is used. Lighting is modeled as non-photorealistic, stylized highlights and shadows are supported. See [Lighting on page 1135](#).

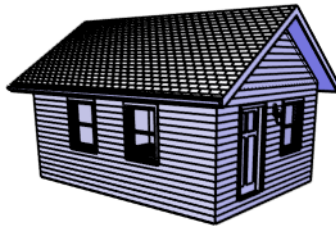

In plan view, the camera symbol for a view using the Technical Illustration technique displays a T in its center.

## WATERCOLOR

 Watercolor rendering approximates the effects of watercolor painting such as pigment pooling and flow. It uses textures to represent materials and models lighting, shadows, and reflections. When Hand Drawn Lines on Top is enabled, pattern lines are also used.



In plan view, the camera symbol for a view using the Watercolor technique displays a W in its center.



## HAND DRAWN LINES



In a Hand Drawn Lines rendering, surface edges are represented by lines with a hand-drawn style. Surfaces are completely opaque and patterns are used, but textures, lighting, and shadows are not.



In plan view, the camera symbol for a view using the Hand Drawn Lines technique displays an H in its center.

Note: In some plans, the Watercolor and Hand Drawn Lines techniques may take a considerable amount of time. You can press the Esc key to cancel the rendering.

## DUOTONE



Duotone rendering represents materials using textures and models lighting, shadows, and reflections. Surface edge lines are not drawn; however, when Hand Drawn Lines on Top is enabled, pattern lines are used. Two colors, one Light and one Dark, are applied over the surfaces, allowing you to create special effects such as sepia tone or grayscale.



In plan view, the camera symbol for a view using the Duotone technique displays a D in its center.

---

## Rendering Technique Options



The settings in the Rendering Technique Options dialog allow you to control the specific effects of each rendering technique on an active 3D view. To access this dialog, create a camera view, cross section/elevation view, or overview and select **3D> Rendering Techniques> Technique Options**.

The Rendering Technique Options dialog can also be accessed by clicking the **Define** button in the active view's specification dialog. See [Camera Panel on page 1117](#).

This dialog can also be accessed by double-clicking the **Rendering Techniques**  parent button.

The settings in the Rendering Technique Defaults dialog are the same as those in this dialog, but control the initial settings of each technique when it is first applied.

In the Rendering Technique Options dialog, select a technique from the list on the left to make its options active on the right. When this dialog is first opened, the technique currently used by the view is selected.

As changes are made in the Rendering Technique Options dialog, the 3D view automatically updates to reflect those changes for all techniques except Watercolor, Hand Drawn Lines, and Physically Based using real-time Ray Tracing. To update views using these techniques, which take more time to draw than the others, click the **Update** button in the dialog. When a 3D view is saved, its Rendering Technique Options settings are saved, as well. See *Saving 3D Views on page 1115*. The Rendering Technique Options dialog has the following panels:

## STANDARD PANEL

 The active 3D view immediately updates to reflect any changes made to the Rendering Technique Options for Standard renderings.

There are a variety of other tools that affect the appearance of Standard rendered views, as well. See *Displaying 3D Views on page 1097*.

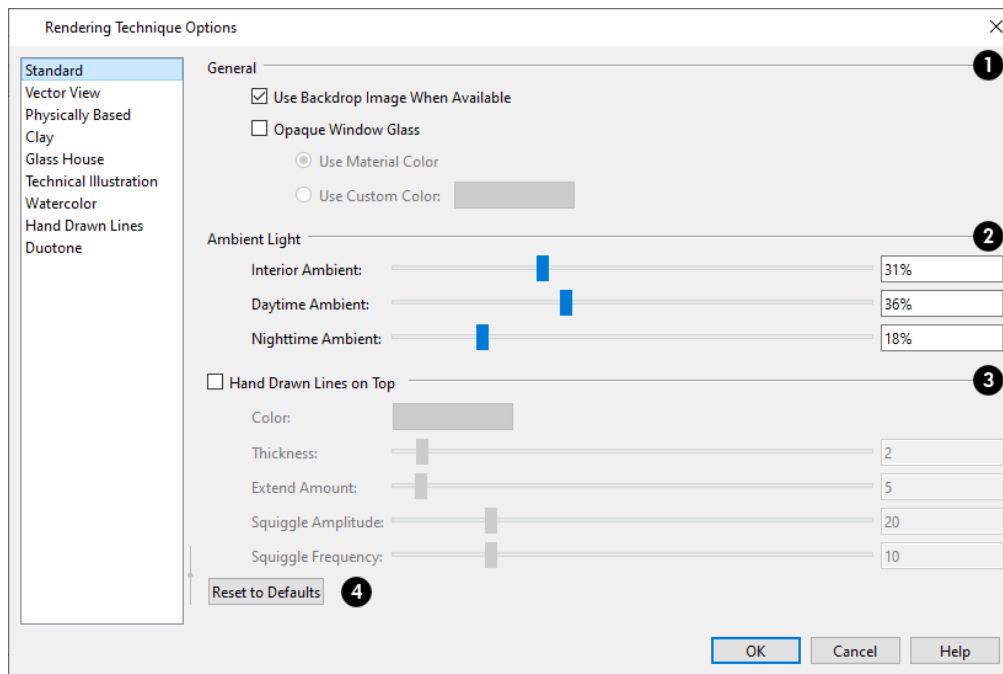

### 1 General

- When **Use Backdrop Image When Available** is checked, the backdrop image specified for this view is used. When unchecked or if no backdrop image is specified for the current view, the specified Backdrop Color is used instead. See *3D Backdrops on page 1204*.
- Check **Opaque Window Glass** to make the glass in windows and exterior doors opaque. When unchecked, door and window glass is transparent. See *Material Transparency on page 1135*.
- When Opaque Window Glass is checked, specify the color of door and window glass:
- Select **Use Material Color** to use the glass material's color. See *Patterns and Textures on page 1050*.
- Select **Use Custom Color** to click the Color button and select a glass color. See *Color Chooser/Select Color Dialog on page 203*.

## 2 Ambient Light

Specify the amount of Ambient light to use in different situations in Standard, Watercolor, and Duotone renderings. See [Ambient Lighting and Occlusion on page 1137](#).

- **Interior Ambient** affects interior views.
- **Daytime Ambient** affects exterior views.
- **Nighttime Ambient** affects nighttime exterior views.

## 3 Hand Drawn Lines on Top

Add lines with a hand-drawn style along surface edges in the current view. Material patterns are also represented. See [Patterns and Textures on page 1050](#).

- Check **Hand Drawn Lines on Top** to enable the settings that follow.
- These settings are also found on the HAND DRAWN LINES panel. See [Hand Drawn Lines Panel on page 1163](#).

## 4 Reset

- Click **Reset to Defaults** to apply the Standard settings defined in the Rendering Technique Defaults dialog.
- In the Rendering Technique Defaults dialog, the **Restore Initial Settings** button is available instead. Click this to reset the options on this panel to the system defaults.

## VECTOR VIEW PANEL



The active 3D view immediately updates to reflect any changes made to the Rendering Technique Options for Vector Views.

Additional settings that affect the appearance of Vector Views can be found in the 3D View Defaults dialog. See [3D View Defaults Dialog on page 1083](#).

There are a variety of other tools that affect the appearance of Vector Views. See [Displaying 3D Views on page 1097](#).

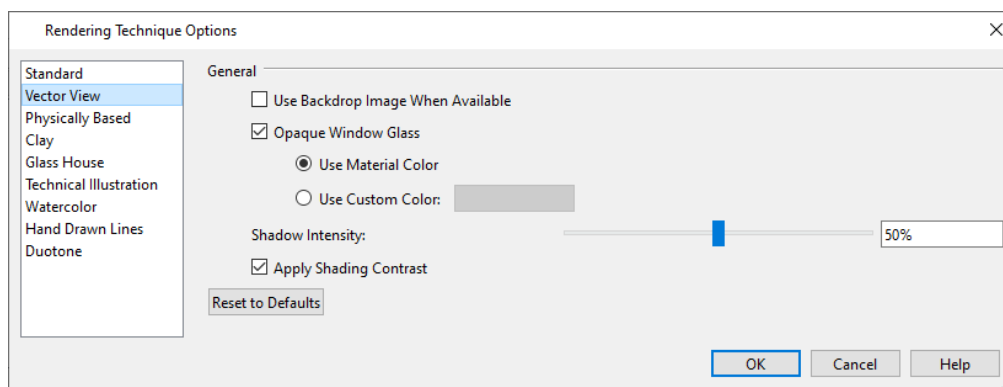

- Check **Use Backdrop Image When Available** to use the backdrop image specified for this view. When unchecked or if no backdrop image is specified for the current view, the specified Backdrop Color is used instead.
- Check **Opaque Window Glass** to make the glass in windows and exterior doors opaque. When unchecked, door and window glass is transparent. See [Material Transparency on page 1135](#).
- When Opaque Window Glass is checked, specify the color of door and window glass:

- Select **Use Material Color** to use the glass material's color. See *Patterns and Textures on page 1050*.
- Select **Use Custom Color** to click the Color button and select a glass color. See *Color Chooser/Select Color Dialog on page 203*.
- Specify the **Shadow Intensity**, which is how dark or light shadows appear. A value of 100% creates shadows that hide any objects located within them; a value of 0% effectively produces no shadows.
- Check **Apply Shading Contrast** to use different levels of shading on surfaces oriented at different angles to the camera. When unchecked, unmodified material Colors are shown on all surfaces. Each material's Shading Contrast can be set individually. See *Pattern Panel on page 1067*.
- Click **Reset to Defaults** to apply the Vector View settings defined in the Rendering Technique Defaults dialog.
- In the Rendering Technique Defaults dialog, the **Restore Initial Settings** button is available instead. Click this to reset the options on this panel to the system defaults.

### PHYSICALLY BASED (RAY TRACE) PANEL

 The active 3D view immediately updates to reflect any changes made to the Rendering Technique Options for Physically Based renderings.

There are a variety of other tools that affect the appearance of Physically Based rendered views, as well. See *Rendering Tips on page 1132*.

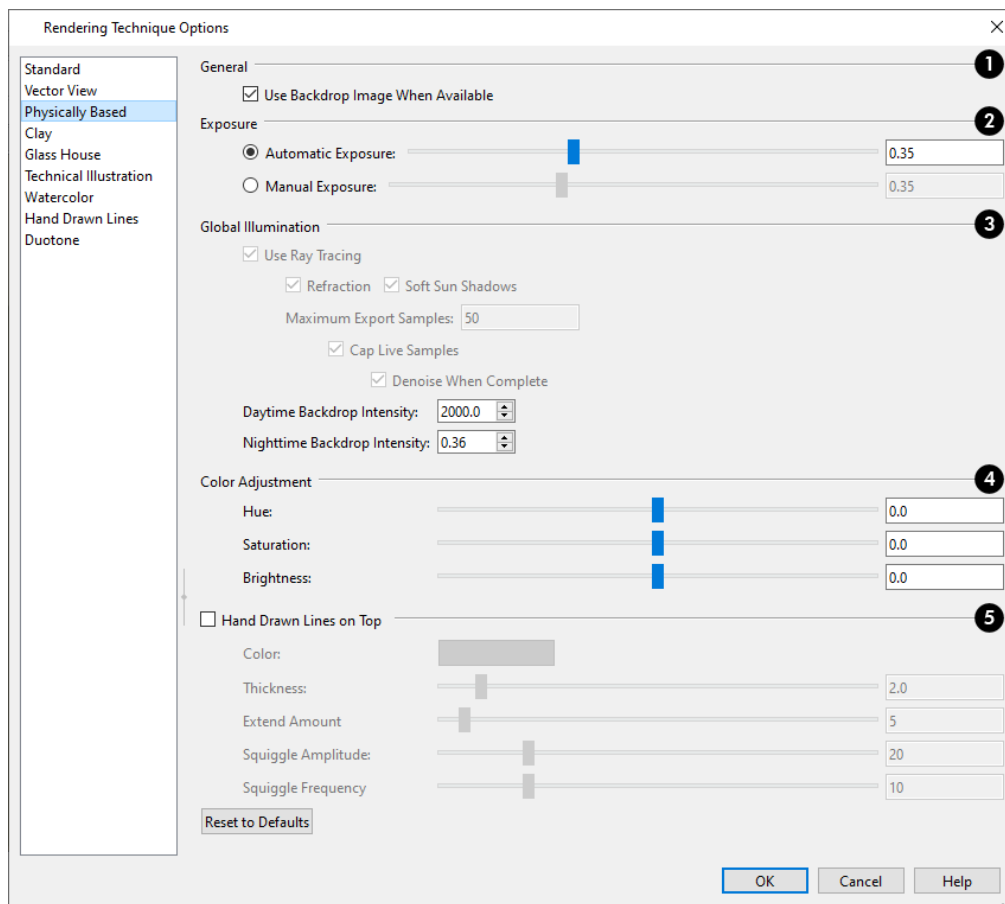

## 1 General

- When **Use Backdrop Image When Available** is checked, the backdrop image specified for this view is used. When unchecked or if no backdrop image is specified for the current view, the specified Backdrop Color is used instead.

## 2 Exposure

Exposure is the amount of light in the scene that is captured by the camera. A low value produces a darker view; too high a value can make the scene look washed out.

- When **Automatic Exposure** is selected, the program automatically adjusts luminance in the scene based on the light sources in use.
- Select **Manual Exposure** to manually adjust the level of luminance. This can sometimes be helpful in some dimly lit scenes.

## 2 Global Illumination

- When **Use Ray Tracing** is active and checked, multiple samples of indirect lighting in the scene are created, improving the lighting quality with each sample. This setting and those below it will not be active if real-time GPU Ray Tracing is not supported on the system. See *GPU Ray Tracing on page 1132*.
- When **Refraction** is active and checked, light will bend when passing through a Transparent material.
- When **Soft Sun Shadows** is checked, the sun casts shadows with soft edges.
- Specify the **Maximum Export Samples**, which is how many samples to take for a view that you wish to export as a picture, print, record a walkthrough, or send to layout as an image. See *Pictures on page 1191* and *Recording a Walkthrough on page 1215*.
- When **Cap Live Samples** is unchecked, a GPU Ray Traced view will run samples indefinitely. Check this box to instead stop running samples when the Maximum Export Samples value is reached.
- When **Denoise When Complete** is checked, exported views are denoised after the Maximum Export Samples are taken. See *Denoising on page 1132*.
  - Specify the **Daytime Background Intensity**, which is the brightness of the view's background color or backdrop image when the Sunlight is toggled on. See *Backdrop Panel on page 1122*.
  - Specify the **Nighttime Background Intensity**, which is the background brightness when the Sunlight is toggled off. See *Sunlight and Moonlight on page 1136*.

## 3 Color Adjustment

You can adjust the **Hue**, **Saturation**, and **Brightness** of the view, if needed.

## 4 Hand Drawn Lines on Top

Add lines with a hand-drawn style along surface edges in the current view. Material patterns are also represented. See *Patterns and Textures on page 1050*.

- Check **Hand Drawn Lines on Top** to enable the settings that follow.
- These settings are also found on the HAND DRAWN LINES panel. See *Hand Drawn Lines Panel on page 1163*.

## 5 Reset

- Click **Reset to Defaults** to apply the Physically Based settings defined in the Rendering Technique Defaults dialog.
- In the Rendering Technique Defaults dialog, the **Restore Initial Settings** button is available instead. Click this to reset the options on this panel to the system defaults.

## CLAY PANEL



The active 3D view immediately updates to reflect any changes made to the Rendering Technique Options for Clay renderings.

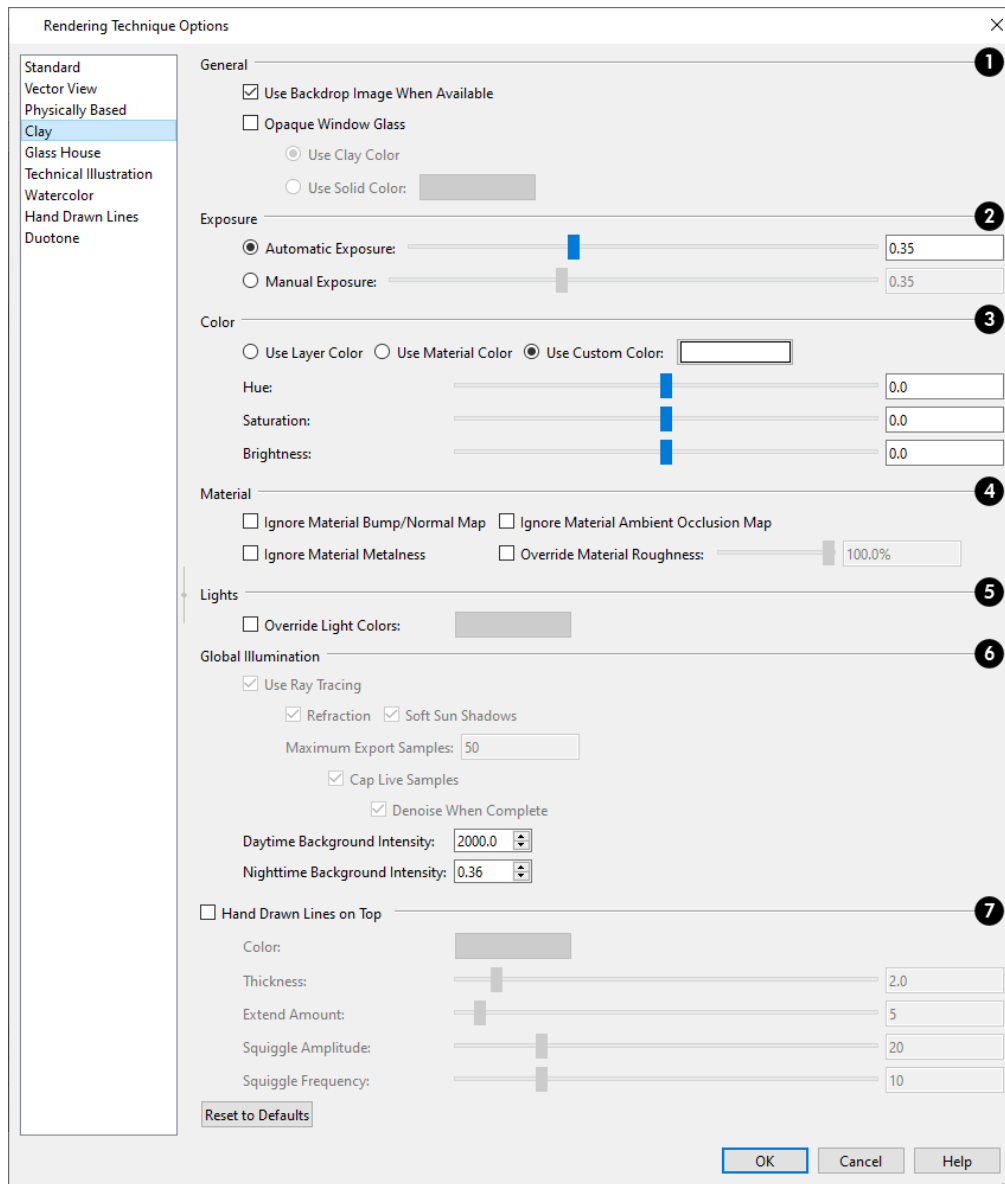

## 1 General

- When **Use Backdrop Image When Available** is checked, the backdrop image specified for this view is used. When unchecked or if no backdrop image is specified for the current view, the specified Backdrop Color is used instead.
- Check **Opaque Window Glass** to make the glass in windows and exterior doors opaque. When unchecked, door and window glass is transparent. See *Material Transparency on page 1135*.
- When Opaque Window Glass is checked, specify the color of door and window glass:
- Select **Use Material Color** to use the glass material's color. See *Patterns and Textures on page 1050*.
- Select **Use Custom Color** to click the Color button and select a glass color. See *Color Chooser/Select Color Dialog on page 203*.
  - Specify the **Camera Exposure**, which is the amount of light in the scene that is captured by the camera. A low value produces a darker view; too high a value can make the scene look washed out.

## 2 Color

Specify the solid color or colors applied to object surfaces in the view.

- Select **Use Layer Color** to apply the colors assigned to layers in the current Layer Set to objects on those layers. See *Line and Text Styles on page 178*.
- Select **Use Material Color** to apply the Material Color associated with each material applied to the surfaces in the view. See *Pattern Panel on page 1067*.
- Select **Use Custom Color** to apply the color displayed in the Color bar to all surfaces in the view. Click the Color bar to choose a new color. See *Color Chooser/Select Color Dialog on page 203*.
- You can adjust the **Hue, Saturation, and Brightness** of the view, if needed.

## 3 Material

Most material properties are represented in Clay renderings but you can choose to suppress or override some of them if you wish. See *Properties Panel on page 1072*.

- Check **Ignore Material Bump/Normal Map** to ignore the Bump and/or Normal Maps assigned to materials in the view.
- Check **Ignore Material Metalness** to ignore the Metallic property or Metal Map assigned to materials in the view.
- Check **Ignore Ambient Occlusion Map** to ignore the Ambient Occlusion Maps assigned to materials in the view.
- Check **Override Material Roughness** to ignore the Roughness setting of materials assigned to any surfaces in the view and instead use a single Roughness value.
- Specify the **Roughness** of all surfaces in the current view.

## 4 Lights

The lights in the current Light Set are used in Clay renderings. See *Lighting on page 1135*.

- When **Override Light Colors** is unchecked, the colors assigned to individual light sources in the view are used. Check this to specify a single color for all lights in the view.
- When **Override Light Colors** is checked, click the Color bar to specify the light color used by all lights in the view.

## 5 Global Illumination

These settings are also found on the PHYSICALLY BASED panel.

## 6 Hand Drawn Lines on Top

Add lines with a hand-drawn style along surface edges in the current view. Material patterns are also represented. See [Patterns and Textures on page 1050](#).

- Check **Hand Drawn Lines on Top** to enable the settings that follow.
- These settings are also found on the HAND DRAWN LINES panel. See [Hand Drawn Lines Panel on page 1163](#).

## 7 Reset

- Click **Reset to Defaults** to apply the Clay settings defined in the Rendering Technique Defaults dialog.
- In the Rendering Technique Defaults dialog, the **Restore Initial Settings** button is available instead. Click this to reset the options on this panel to the system defaults.

## GLASS HOUSE PANEL



The active 3D view immediately updates to reflect any changes made to the Rendering Technique Options settings for Glass House renderings.

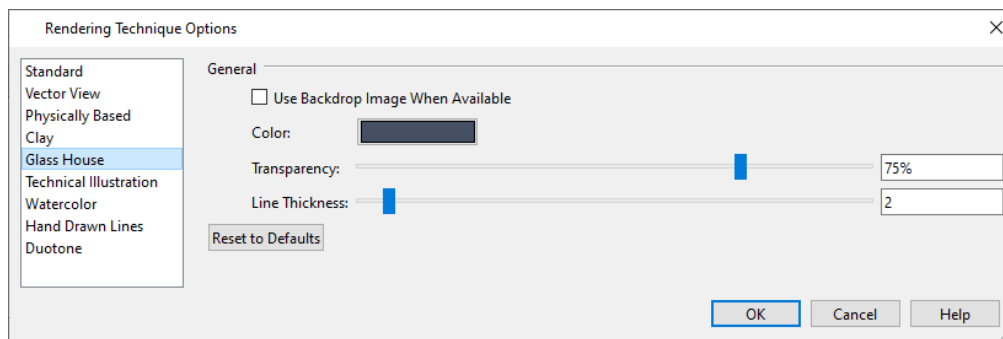

- When **Use Backdrop Image When Available** is checked, the backdrop image specified for this view is used. When unchecked or if no backdrop image is specified for the current view, the specified Backdrop Color is used instead. See [3D Backdrops on page 1204](#).
- Click the **Color** bar to select a color for the semi-transparent surfaces and lines in a Glass House view. See [Color Chooser/Select Color Dialog on page 203](#).
- Specify the **Transparency** of the surfaces in Glass House view. For example, to create a wireframe line drawing of your structure, turn transparency to full and minimize line thickness.
- Specify the **Line Thickness** of surface lines in Glass House view.
- Click **Reset to Defaults** to apply the Glass House settings defined in the Rendering Technique Defaults dialog.
  - In the Rendering Technique Defaults dialog, the **Restore Initial Settings** button is available instead. Click this to reset the options on this panel to the system defaults.

## TECHNICAL ILLUSTRATION PANEL



The active 3D view immediately updates to reflect any changes made to the Rendering Technique Options settings for Technical Illustration renderings.



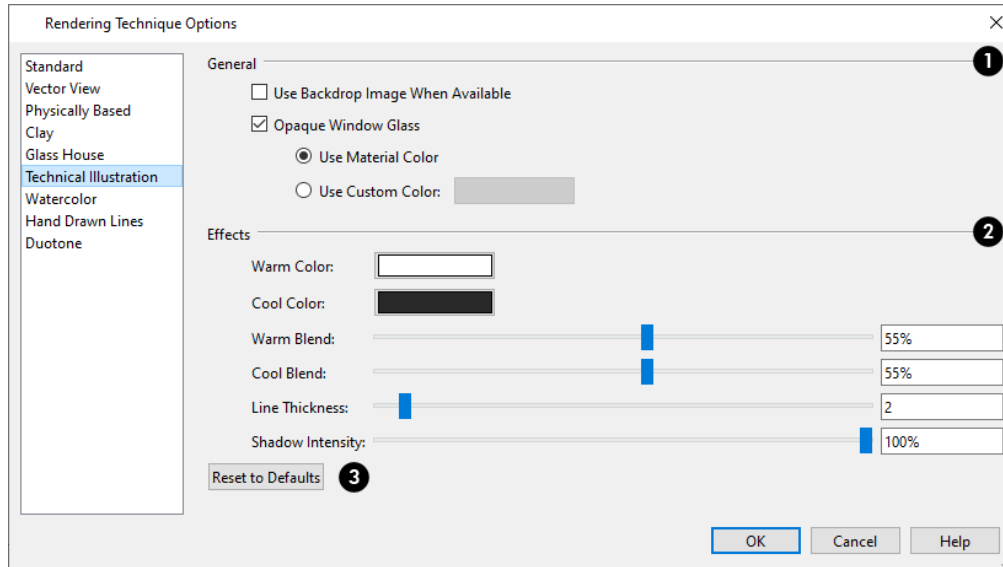

## 1 General

- When **Use Backdrop Image When Available** is checked, the backdrop image specified for this view is used. When unchecked or if no backdrop image is specified for the current view, the specified Backdrop Color is used instead. See [3D Backdrops on page 1204](#).
- Check **Opaque Window Glass** to make the glass in windows and exterior doors opaque. When unchecked, door and window glass is transparent. See [Material Transparency on page 1135](#).
- When Opaque Window Glass is checked, specify the color of door and window glass:
- Select **Use Material Color** to use the glass material's color. See [Patterns and Textures on page 1050](#).
- Select **Use Custom Color** to click the Color button and select a glass color. See [Color Chooser/Select Color Dialog on page 203](#).

## 2 Effects

- Click the **Color** bar to select a **Warm Color** for surfaces that face the light source and a **Cool Color** for surfaces that face away from the light. See [Color Chooser/Select Color Dialog on page 203](#).
- Specify the **Warm Blend**, which is the degree to which the selected Warm Color is blended with original colors on well-lit surfaces in the view.
- Specify the **Cool Blend**, which is the degree to which the selected Cool Color is blended with original colors on shaded surfaces in the view.
- Specify the **Line Thickness** of all surface edge and pattern lines in the view. Surface Edge Line color in Technical Illustrations can be set by layer in the Layer Display Options dialog when **Use Layer Settings** is selected in the 3D View Defaults dialog. Some objects' Surface Edge Line color can also be set per object. See [3D View Defaults Dialog on page 1083](#).
- Specify the **Shadow Intensity**, which is how dark shadows. A value of 0% produces no shadows. See [Shadows on page 1133](#).

### 3 Reset

- Click **Reset to Defaults** to apply the Technical Illustration settings defined in the Rendering Technique Defaults dialog.
- In the Rendering Technique Defaults dialog, the **Restore Initial Settings** button is available instead. Click this to reset the options on this panel to the system defaults.

## WATERCOLOR PANEL



In order for the active 3D view to reflect changes made to the Rendering Technique Options settings for Watercolor renderings, you must click either the OK button or the **Update View** button in the dialog. This may take several moments.

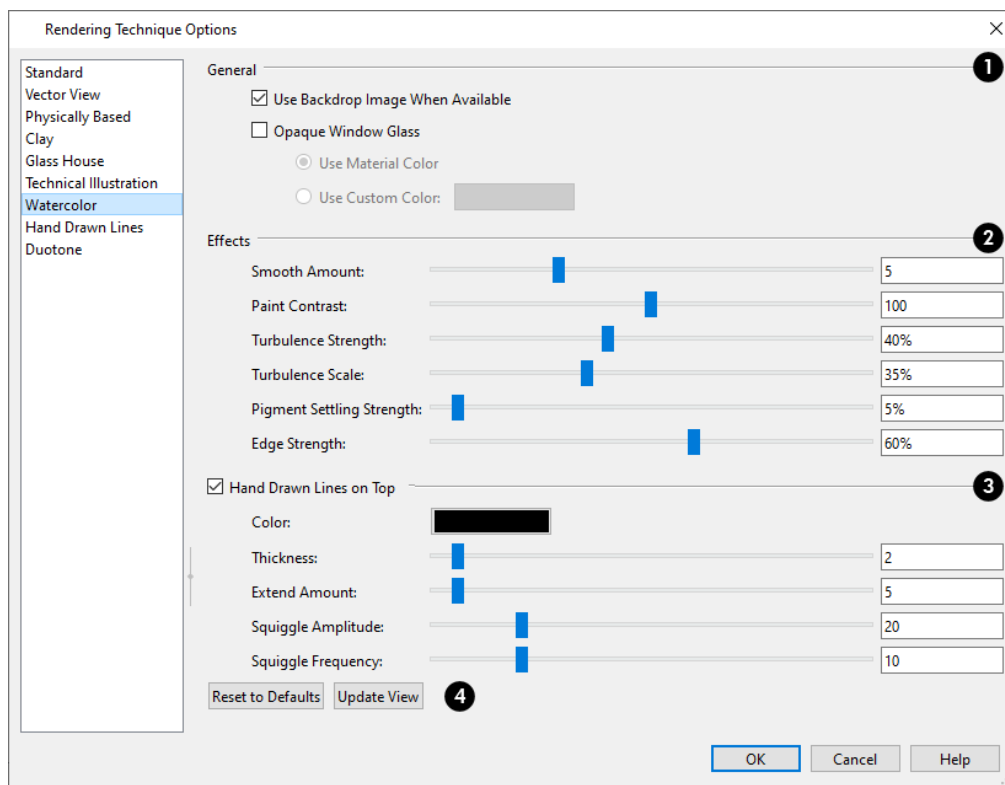

### 1 General

- When **Use Backdrop Image When Available** is checked, the backdrop image specified for this view is used. When unchecked or if no backdrop image is specified for the current view, the specified Backdrop Color is used instead.
- Check **Opaque Window Glass** to make the glass in windows and exterior doors opaque. When unchecked, door and window glass is transparent. See [Material Transparency on page 1135](#).
- When Opaque Window Glass is checked, specify the color of door and window glass:
- Select Use **Material Color** to use the glass material's color. See [Patterns and Textures on page 1050](#).
- Select Use **Custom Color** to click the Color button and select a glass color. See [Color Chooser/Select Color Dialog on page 203](#).

## 2 Effects

- Specify the **Smooth Amount**, which is the degree to which details are removed from the original view.
- Specify the **Paint Contrast**, which determines the extent to which variations in pigment color are used.
- Specify the **Turbulence Strength**, which produces “pooling”, or variations in the strength of pigment colors.
- Specify the **Turbulence Scale**, which controls the size of the areas of pooling.
- Specify the **Pigment Settling Strength**, which is creates the appearance of pigment settling into low areas in paper.
- Specify the **Edge Strength**, which is how well-defined surface edge lines are.

## 3 Hand Drawn Lines on Top

Add lines with a hand-drawn style along surface edges in the current view. Material patterns are also represented. See *Patterns and Textures on page 1050*.

- Check **Hand Drawn Lines on Top** to enable the settings that follow.
- These settings are also found on the HAND DRAWN LINES panel. See *Hand Drawn Lines Panel on page 1163*.

## 4 Reset

- Click **Reset to Defaults** to apply the Watercolor settings defined in the Rendering Technique Defaults dialog.
- In the Rendering Technique Defaults dialog, the **Restore Initial Settings** button is available instead. Click this to reset the options on this panel to the system defaults.
- Views using the Watercolor technique do not update as changes are made to the settings here as they do with most Rendering Techniques. Click **Update View** to apply any changes to these settings to the current view.

## HAND DRAWN LINES PANEL



Lines with a hand-drawn appearance can also be drawn in the Standard, Physically Based, Clay, Watercolor, and Duotone Rendering Techniques.

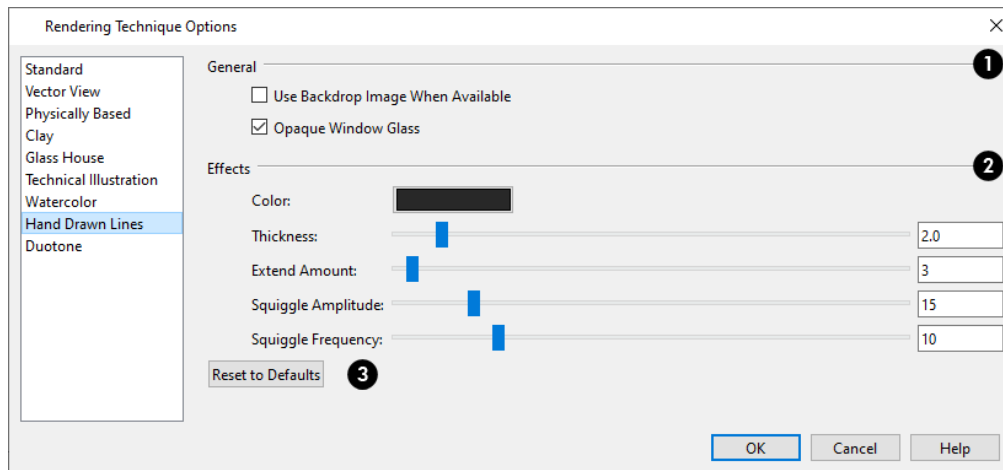

## 1 General

- When **Use Backdrop Image When Available** is checked, the backdrop image specified for this view is used. When unchecked or if no backdrop image is specified for the current view, the specified Backdrop Color is used instead.
- Check **Opaque Window Glass** to make the glass in windows and exterior doors opaque. When unchecked, door and window glass is transparent. See *Material Transparency on page 1135*.

## 2 Effects

- Click the **Color** bar to select the color of the lines used to draw the view.
- Specify the **Thickness** of the lines, in scaled pixels.
- Specify the **Extend Amount**, which is the distance that lines may extend past intersecting surface edges.
- Specify the **Squiggle Amplitude**, which controls the average amount of curvature in the lines' squiggles. A value of 0 produces straight lines.
- Specify the **Squiggle Frequency**, which controls how often the lines have curves. A value of 0 produces straight lines.

## 3 Reset

- Click **Reset to Defaults** to apply the Hand Drawn Lines settings defined in the Rendering Technique Defaults dialog.
- In the Rendering Technique Defaults dialog, the **Restore Initial Settings** button is available instead. Click this to reset the options on this panel to the system defaults.

## DUOTONE PANEL



The active 3D view immediately updates to reflect any changes made to the Rendering Technique Options settings for Duotone renderings.

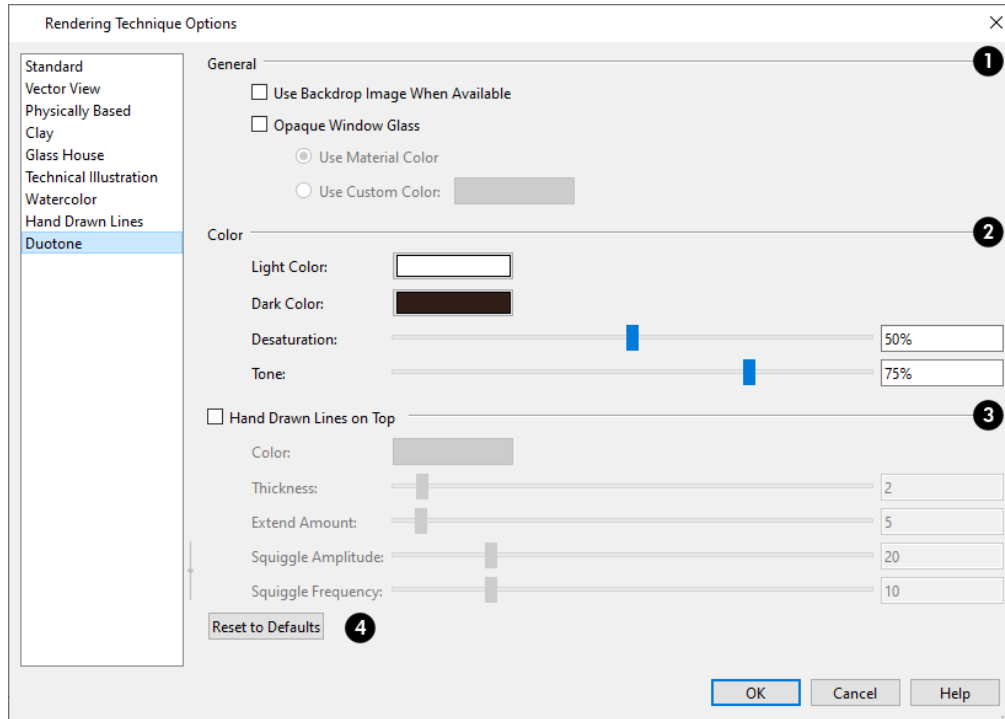

## 1 General

- When **Use Backdrop Image When Available** is checked, the backdrop image specified for this view is used. When unchecked or if no backdrop image is specified for the current view, the specified Backdrop Color is used instead. See *3D Backdrops on page 1204*.
- Check **Opaque Window Glass** to make the glass in windows and exterior doors opaque. When unchecked, door and window glass is transparent. See *Material Transparency on page 1135*.
- When Opaque Window Glass is checked, specify the color of door and window glass:
- Select **Use Material Color** to use the glass material's color. See *Patterns and Textures on page 1050*.
- Select **Use Custom Color** to click the Color button and select a glass color. See *Color Chooser/Select Color Dialog on page 203*.

## 2 Color

- Click the **Color** bars to select a **Light Color** and **Dark Color** for surfaces and lines in a Duotone view. See *Color Chooser/Select Color Dialog on page 203*.
- Specify the **Desaturation**, which is the degree to which color is removed from the original image. A value of 0% retains the original colors in the view while a 100% results in a grayscale image.
- Specify the **Tone**, which is the extent to which the **Light** and **Dark Colors** cover the original colors in the view. A value of 100% completely obscures the view's original colors as well as the effects of Desaturation.

## 3 Hand Drawn Lines on Top

Add lines with a hand-drawn style along surface edges in the current view. Material patterns are also represented. See *Patterns and Textures on page 1050*.

- Check **Hand Drawn Lines on Top** to enable the settings that follow.
- These settings are also found on the HAND DRAWN LINES panel. See *Hand Drawn Lines Panel on page 1163*.

#### **4** Reset

- Click **Reset to Defaults** to apply the Duotone settings defined in the Rendering Technique Defaults dialog.
- In the Rendering Technique Defaults dialog, the **Restore Initial Settings** button is available instead. Click this to reset the options on this panel to the system defaults.

# CPU Ray Tracing

## Chapter 34

As the name implies, ray tracing calculates the rays of light in a view as they travel through the 3D model and reflect off surfaces. It can be used to achieve much more complex lighting effects than regular 3D rendering; however, it is also more demanding of your system's resources. There are two types of ray tracing in Chief Architect: GPU and CPU Ray Tracing.

GPU Ray Tracing is produced in real time using the graphics card but is only supported by some newer cards on PCs running Windows 10. See *GPU Ray Tracing on page 1132*.

CPU Ray Tracing uses the system's processor, or CPU, and can be run on any system that meets Chief Architect's system requirements. It supports queuing of multiple jobs, can be run for extended periods of time, and runs in its own process so you can continue to work in Chief Architect while it runs.





### TOPICS





<b>CPU Ray Trace Views</b> .....	<b>1168</b>
<b>CPU Ray Trace Configurations</b> .....	<b>1169</b>
<b>CPU Ray Trace Options</b> .....	<b>1171</b>
<b>CPU Ray Trace Assistant</b> .....	<b>1176</b>
<b>Adjusting Ray Trace Properties and Effects</b> .....	<b>1179</b>
<b>CPU Ray Tracing Tips</b> .....	<b>1180</b>

## CPU Ray Trace Views

 CPU ray trace views are generated in their own view window and are static images of the model - not dynamic. That is, if you make changes to the 3D model, any previously created ray trace views will not be affected. In contrast, see [GPU Ray Tracing on page 1132](#).

### To create a CPU ray trace

1. Create a 3D camera view or overview.
  - The Standard or Physically-Based Rendering Technique must be used. See [Rendering Techniques on page 1150](#).
  - Perspective views are preferable to Orthographic views for ray tracing because they are more realistic to the human eye. See [Perspective and Orthographic Views on page 1080](#).
  - The **Hide Camera-Facing Exterior Walls**  setting must be toggled off. See [Hide Camera-Facing Exterior Walls on page 1135](#).
2. Position the camera as needed. Do not use the Zoom or Pan tools. See [Editing 3D Views on page 1105](#).
3. Adjust the shape of the view window as needed.
4. Select **3D> CPU Ray Trace** .
5. In the Ray Trace Current View dialog:
  - Select a Ray Trace Configuration from the drop-down list and click the **Ray Trace** button. See [CPU Ray Trace Current View/CPU Ray Trace Defaults Dialog on page 1170](#).
6. To pause a ray trace in progress, select **File> Pause Ray Trace** .
  - Select **File> Resume Ray Trace**  to restart a paused ray trace.

Note: If you have ray traces in queue and pause the one in progress, the next ray trace will begin running. See [Queuing CPU Ray Trace Jobs on page 1182](#).
7. A ray trace can be canceled at any time:
  - In the Preparing to Ray Trace progress dialog, click the **Cancel** button.
  - Once the CPU ray trace view window is open, you can cancel the process by selecting **File> Close** or click the Close **×** button.
8. To stop a ray trace in progress without canceling it, select **File> Stop Ray Trace** .
9. When the ray trace is completed, save the resulting image for future use:
  - Select **File> Print Image**  to print the image. See [Print Image Dialog on page 1383](#).
  - Select **File> Export Picture**  to save the image in any of several file formats including **.jpg**, **.bmp**, and **.png**. See [Exporting Pictures on page 1191](#).
  - Select **File> Send to Layout**  to send the ray trace view to a layout page. See [Sending Views to Layout on page 1338](#).



- Select **File> Export 360 Panoramic Ray Trace to Cloud**  to export a completed panoramic ray trace to your Chief Architect cloud account. See *Export 360 Panorama on page 1238*.

## PROGRESSIVE CPU RAY TRACING

Chief Architect’s CPU ray tracer begins by generating a low-quality preview of the model based on the current Ray Trace Configuration’s settings. Once the initial ray trace is complete, the ray tracer performs additional passes to incrementally refine the view’s lighting quality and effects.

If **Save Image to File** is checked in the CPU Ray Trace Options dialog, the program will save the ray trace as an image file and will update the file after every pass of the ray tracer. See *General Panel on page 1171*.



You can specify how long these additional passes are performed in the CPU Ray Trace Options dialog, and can stop a ray trace in progress whenever it meets your needs by selecting **File> Stop Ray Trace** . See *General Panel on page 1171*.

## THE CPU RAY TRACE WINDOW

The tab of a CPU Ray Trace view window states the names of the plan file and of the camera the CPU Ray Trace is derived from. While a ray trace view is generating, you can switch to a different view and perform other tasks. See *Working in Multiple Views on page 150*.

When the CPU Ray Trace view window is active, the image will regularly update as the ray trace progresses and its status will display in the Status Bar. When it is finished, the number of passes and cumulative time, including pre-processing time, will display there. See *The Status Bar on page 24*.

You can specify whether your computer’s processor allocates more resources for the CPU ray trace or for working in the program in the Preferences dialog. See *Ray Trace Panel on page 125*.

If you have specified an image size larger than your monitor and saved the results as an image file, you may only see one corner of the total view. You can, however, use the scrollbars and/or **Zoom In**  or **Zoom Out** . See *Zoom Tools on page 153*.

---

# CPU Ray Trace Configurations



CPU Ray Trace views are generated based on settings that control lighting properties as well as the size of the final image. Two configurations are included in the installed template plans: Default Interior Ray Trace and Default Exterior Ray Trace.

You can save multiple CPU Ray Trace configurations for different purposes and then select the one best suited to the view you want to ray trace. See *Multiple Saved Defaults on page 79*.

To access the CPU Ray Trace configurations saved in the current plan, select **Edit> Default Settings** . Click the + beside “3D View Defaults”, then select “CPU Ray Trace” and click the **Edit** button to open the CPU Ray Trace Defaults dialog. See *Default Settings on page 77*.

You can also access the available CPU Ray Trace configurations by selecting **3D> CPU Ray Trace**  while a 3D camera view or overview is active. The CPU Ray Trace Current View dialog will open.

## CPU RAY TRACE CURRENT VIEW/CPU RAY TRACE DEFAULTS DIALOG

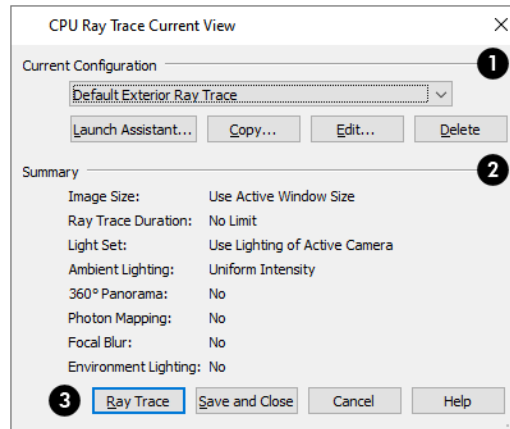



### 1 Current Configuration

- Select the name of the **Current Configuration** from the drop-down list. A **Summary** of the selected configuration's settings displays in the bottom portion of the dialog box.
- Click the **Launch Assistant** button to launch the CPU Ray Trace Assistant. See *CPU Ray Trace Assistant on page 1176*.
- Click the **Copy** button to create a copy of the Current Configuration.
- Click the **Edit** button to open the CPU Ray Trace Options dialog, where you can make changes to the selected Current Configuration. See *CPU Ray Trace Options on page 1171*.
- Click the **Delete** button to permanently remove the Current Configuration from the plan. Not available if there is only one configuration in the list.

### 2 Summary

Information about the currently selected configuration is reported here.



### 3

- If the CPU Ray Trace Current View dialog was accessed via the **Ray Trace**  tool, click the **Ray Trace** button to begin ray tracing the active 3D view using the Current Configuration and retain any new configurations or changes made to existing configurations.
- If the CPU Ray Trace Current View dialog was accessed via the **Ray Trace**  tool, click the **Save and Close** button to close the dialog without ray tracing the current view. Any new configurations or changes that you may have made to existing configurations are retained.
- If the CPU Ray Trace Defaults dialog was accessed via **Default Settings** , click **OK** to close the dialog and save any newly created or renamed configurations.
- Click the **Cancel** button to close the dialog without saving any changes. Any renamed or newly created configurations will not be retained.

 You can add your preferred CPU Ray Trace configurations to your template plan. See [Template Files on page 87](#).

## CPU Ray Trace Options

The CPU Ray Trace Options dialog can be opened in either of two ways:

- In any view, select **Edit> Default Settings**  and expand the “3D View Defaults” category. See [Default Settings on page 77](#).
- In a Standard or Physically Based rendered view, select **3D> CPU Ray Trace** .

In either case, you will first need to select the current ray trace configuration in the CPU Ray Trace Configurations/CPU Ray Trace Current View dialog. See [CPU Ray Trace Current View/CPU Ray Trace Defaults Dialog on page 1170](#).

When the CPU Ray Trace Options dialog opens, the Current Configuration specified in the CPU Ray Trace Current View dialog is active. See [CPU Ray Trace Configurations on page 1169](#).

The CPU Ray Trace Options dialog has the following panels:

### GENERAL PANEL

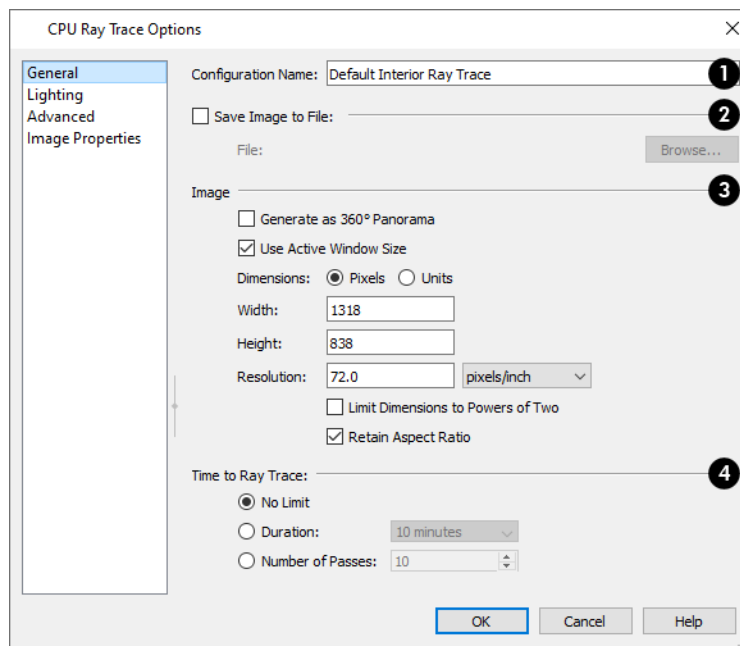

#### 1 Configuration Name

Specify the name of the current Ray Trace Configuration. Names must be unique.

## 2 Save Image to File

- Check **Save Image to File**, then click the **Browse** button to save the ray trace image directly to a **.jpg**, **.bmp**, **.png**, or **.png** file after every pass of the progressive ray tracer.
- If a file has been specified, its pathname will display to the right of the **Choose** button.

If the specified file already exists, the program will ask if you wish to overwrite the existing file or choose a new name and/or location when you start a ray trace.



## 3 Image

Specify size and other characteristics of the ray trace image.

- Check **Generate as 360° Panorama** to create a spherical image that can be viewed in a variety of other applications. See *Export 360 Panorama on page 1238*.
- Check **Use Active Window Size** to save the ray trace image at the same size as the ray trace view window. The Width and Height of the currently active view window are stated below: if these values are changed, this box becomes unchecked automatically.
- Specify whether the ray trace image's Width/Height **Dimensions** are measured using **Pixels** or drawing **Units** (inches or mm).
- Specify the **Width** and **Height** of the ray trace image in either Pixels or Units.
- Specify the **Resolution** of the ray trace image, in either Pixels/Inch or Pixels/mm.
- Check **Limit Dimensions to Powers of Two** to restrict the Width and Height to values that are powers of two. When this is checked and an ineligible value is entered, it will adjust up or down to the nearest power of two. This option recommended when Generate as 360° Panorama is checked, above.
- Check **Retain Aspect Ratio** to maintain the width to height ratio of the original image and prevent the ray trace from being stretched or distorted. This option cannot be unchecked when Generate as 360° Panorama is checked, above.

## 4 Time to Ray Trace

How long a ray trace runs influences its final quality. See *Progressive CPU Ray Tracing on page 1169*.

- Select **No Limit** to run the ray tracer until you select **File> Stop Ray Trace** .
- Select a **Time** to ray trace from the drop-down list. The ray tracer will complete as many passes as possible during this time.
- Specify a **Number of Passes**. The ray tracer will run as long as needed to complete this number of passes.
- You can stop any ray trace at any time by selecting **File> Stop Ray Trace** .

## LIGHTING PANEL

The settings on the LIGHTING panel control the appearance of light in a CPU ray trace scene that isn't associated with a particular light source. See *Lighting on page 1135*.

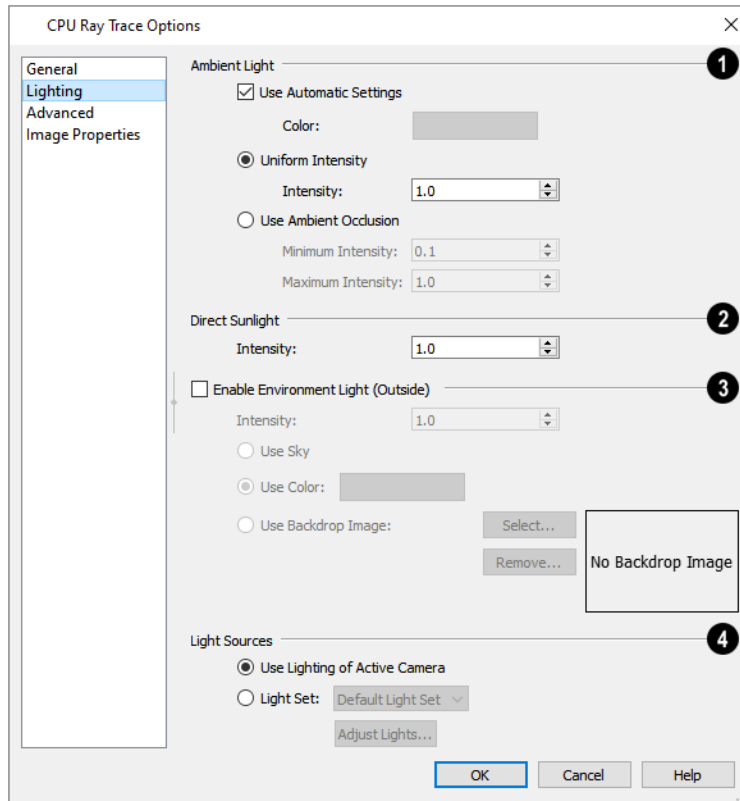

## 1 Ambient Light

Control the appearance of the light present throughout a scene that does not come from a particular source. Ambient light exists everywhere, including shadowed areas. See [Ambient Lighting and Occlusion on page 1137](#).

- Uncheck **Use Automatic Settings** to enable the **Color** bar and specify the color of the ambient light. See [Color Chooser/Select Color Dialog on page 203](#).
- When **Use Automatic Settings** is checked, the ambient light is grey in color and its brightness is based on the ambient light settings in the Rendering Technique Options dialog. Low ambient values result in darker grey; higher values result in lighter grey. See [Standard Panel on page 1154](#).
- Select **Uniform Intensity** to enable the **Intensity** setting below, then specify the strength of the ambient light throughout the scene either by typing a decimal value in the text field or by clicking the up and down arrows. Values between 0 and 10 can be used.
- Select **Use Ambient Occlusion** to enable the **Minimum** and **Maximum Intensity** settings below. Ambient Occlusion allows variation in the strength of the Ambient Light and is more realistic than Uniform Intensity, but takes longer to ray trace.
- Specify the **Minimum Intensity**, which is the strength of the ambient light on surfaces with minimum exposure to it.
- Specify the **Maximum Intensity**, which is the strength of the ambient light on surfaces fully exposed to it.

## 2 Direct Sunlight

- Specify the **Intensity** of the sunlight throughout the scene either by typing a decimal value in the text field or by clicking the up and down arrows. Values between 0 and 10 can be used.

## 3 Enable Environment Light

Specify the appearance of atmospheric lighting in exterior views.

- Check **Enable Environment Light** to enable the settings below. When checked, exterior scenes are lit using an encompassing sphere of light, which simulates how light bounces around within the atmosphere. When unchecked, only the Generic Sun is used. See *Sunlight and Moonlight on page 1136*.
- Specify the **Intensity** value, which is the strength of the Environmental Light.
- Click the **Use Sky** radio button to use the Generated Sky as a basis for the Environmental Light's color. See *3D Backdrops on page 1099*.
- Click the **Use Color** radio button, then click the **Color** bar to specify the color of the outdoor Environmental Light.
- Click the **Use Backdrop Image** radio button, then browse to select an image to use as a basis for the Environmental Light's color. The image is wrapped around the scene's encompassing sphere and influences the color of the Environmental Light, but does not actually appear in the ray trace view.
- Click the **Select** button to select a different image.
- Click the **Remove** button to remove the currently selected image and use a color instead.

## 4 Light Sources

Control which Added Lights and light sources associated with fixtures are used in the ray trace view. See *Light Types on page 1137*.

- Select **Use Lighting of Active Camera** to use the same lighting in the ray trace as in the original camera view. See *Camera Panel on page 1117*.
- Select **Light Set**, then choose a Light Set to use in the ray trace from the drop-down list. See *Light Sets on page 1139*.
- When Light Set is selected, you can click the **Adjust Lights** button to open the Adjust Lights dialog.

## ADVANCED PANEL

The settings on the ADVANCED panel allow you to specify lighting quality and focal blur.

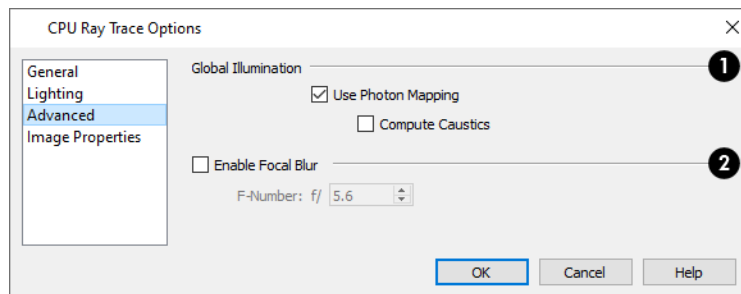

## 1 Global Illumination

- Check **Use Photon Mapping** to accurately calculate bounced lighting in a scene. When unchecked, ray traces have low quality lighting effects but generate more quickly. Use Photon Mapping should be checked for all interior scenes and unchecked for most exterior scenes.

 In order for Photon Mapping to function, at least two different objects must be present in the model. If there are too few surfaces, a ray trace with Photon Mapping cannot run.

- Check **Compute Caustics**, to use caustic photons, which are photons used in areas of focused light. Caustic photons are helpful when modeling certain effects such as light shining through glass.

## 2 Enable Focal Blur

- Check **Enable Focal Blur** to enable the F-Number setting below and set the amount of focal blur that occurs outside the camera’s focal range.
- Specify the **F-Number** value, which defines the camera focal blur and is the like the f-stop in photography. Decrease this value for more focal blur or increase it for less blur.
- Focal blur cannot be produced if the camera’s focal point is located within the Clip Surfaces Within distance set in its specification dialog. See [Camera Panel on page 1117](#).

## IMAGE PROPERTIES PANEL

The settings on the IMAGE PROPERTIES panel allow you to customize the properties of colors in Ray Trace views. Once a Ray Trace has been started, these settings can be modified. See [Adjusting Ray Trace Properties and Effects on page 1179](#).

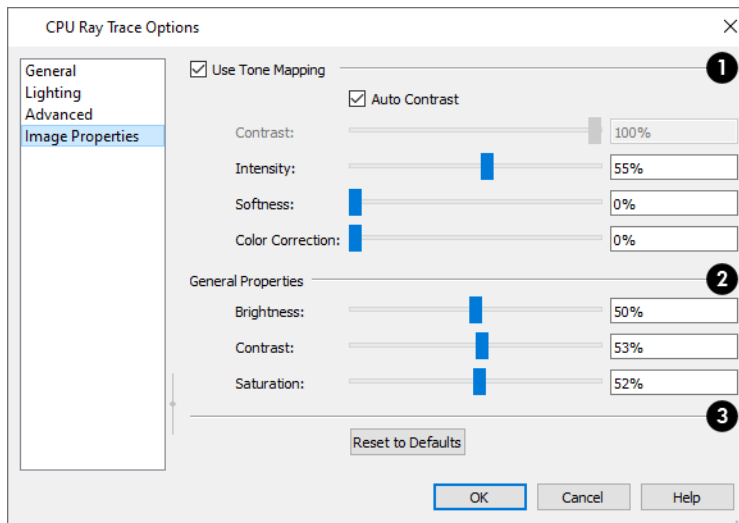

## 1 Use Tone Mapping

Chief Architect’s CPU ray tracer works with a color range greater than what your monitor or printer can display. When **Use Tone Mapping** is checked, these colors are intelligently mapped to a displayable range. Uncheck this box to simplify how the colors are converted and disable the settings below.

- Uncheck **Auto Contrast** to enable the Contrast setting below. When checked, the program chooses a Contrast value based on the image’s properties.

- Specify the **Contrast**, which is the relative difference between light and dark colors in the view, using the slider bar or by typing in the text field
- Specify the **Intensity**, or brightness, of the image. This value not necessarily uniform throughout the view and is similar to a camera's exposure setting.
- Specify the **Softness**, which determines whether color intensity is based on pixel or overall image intensity.
- Specify the **Color Correction**, which is the extent to which strong color casts are removed from the image.



It's not unusual for ray traced images to initially be too dark or too bright. Try adjusting the Tone Mapping Intensity.

## 2 General Properties

- Specify the **Brightness** of the image, which controls how dark or light the image is overall.
- Specify the **Contrast**, or relative difference between light and dark colors. This setting is similar to the setting of the same name, above, but is not as fine a control because it takes place after tone mapping has been done.
- Specify the **Saturation**, which is the intensity of colors in the view.

Don't be afraid to over-saturate your image slightly in very bright scenes – this is a common occurrence in actual photographs.

If you are ray tracing an interior scene where the primary source of light is the sun through a window or door, you may need to adjust your image brightness.

## 3 Reset to Defaults

Click this button to restore the settings in this dialog to their initial, installed values.

---

# CPU Ray Trace Assistant

The CPU Ray Trace Assistant is an easy way to set up new CPU ray trace configurations. It can be accessed by clicking the **Create New** button in the CPU Ray Trace Current View/CPU Ray Trace Defaults dialog. See [CPU Ray Trace Current View/CPU Ray Trace Defaults Dialog on page 1170](#).

The choices in the Ray Trace Assistant correspond to settings in the CPU Ray Trace Options dialog. See [CPU Ray Trace Options on page 1171](#).



## WELCOME

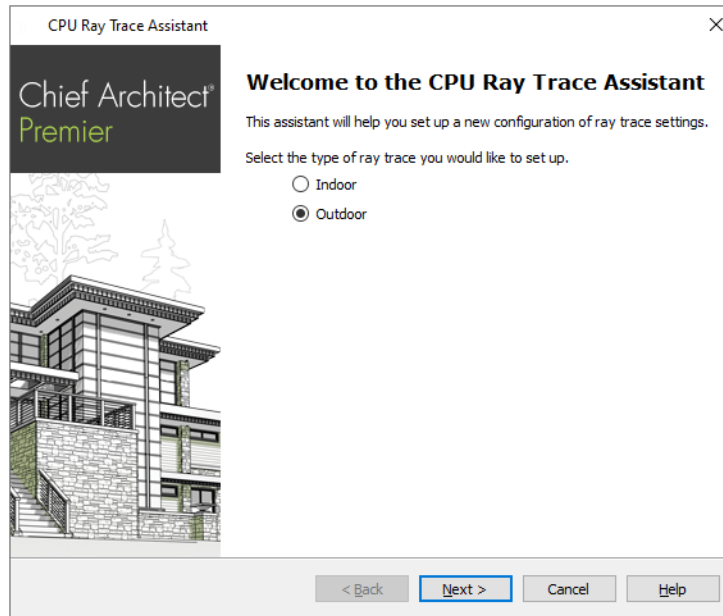

Select **Indoor** or **Outdoor** for a ray trace with lighting effects suitable for the type of view.

## IMAGE SIZE

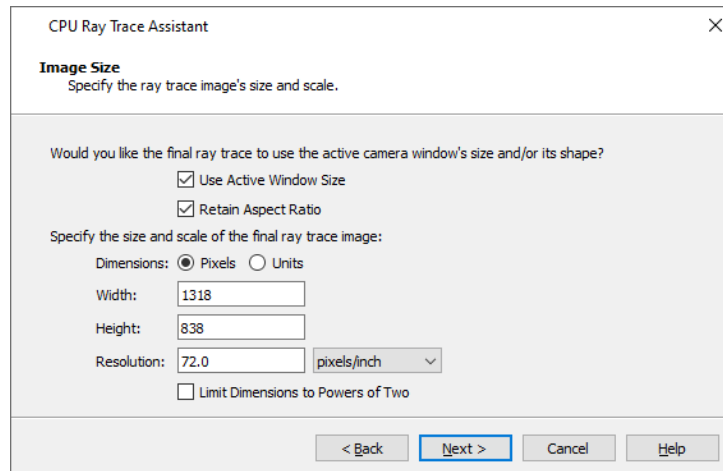

Specify the size of the final ray trace image. The options here correspond to the Image Size settings in the CPU Ray Trace Options dialog. See [General Panel on page 1171](#).

- Check **Use Active Window Size** to set the ray trace to the current size of the active 3D view window. When this is checked, the other settings on this panel are disabled.
- Check **Retain Aspect Ratio** to maintain the width to height ratio of the original image and prevent the ray trace from being stretched or distorted.
- Specify the **Dimensions** used to measure the Width and Height of the ray trace image: either **Pixels** or drawing **Units**.
- Specify the **Width** and **Height** of the ray trace image, in either **Pixels** or **Units**.
- Specify the **Resolution** of the ray trace image, in either Pixels/Inch or Pixels/mm.

- Check **Limit Dimensions to Powers of Two** to restrict the Width and Height to values that are powers of two. When this is checked and an ineligible value is entered, it will adjust up or down to the nearest power of two. This option is recommended if you are likely to use the Generate as 360° Panorama. See [Export 360° Panorama on page 1238](#).

## ENVIRONMENT LIGHTING

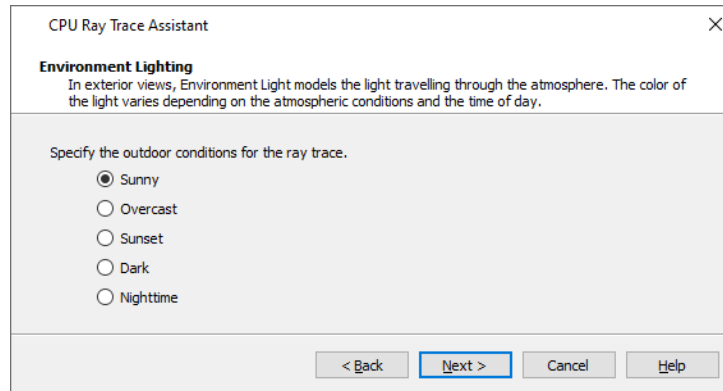

The ENVIRONMENT LIGHTING panel is only available when Exterior is selected on the Welcome page. Specify the atmospheric conditions of the exterior view you would like to ray trace. The options here correspond to the **Outdoor Render Settings** in the Ray Trace Options dialog. See [Lighting Panel on page 1172](#).

- Select **Sunny** for environmental lighting that is white in color.
- Select **Overcast** for environmental lighting that uses a pale gray color.
- Select **Sunset** for environmental lighting that uses a pale orange color.
- Select **Dark** for environmental lighting that uses a dark blue color.
- Select **Nighttime** for environmental lighting that uses a dark blue color with a greater intensity than Dark uses.

## FOCAL BLUR

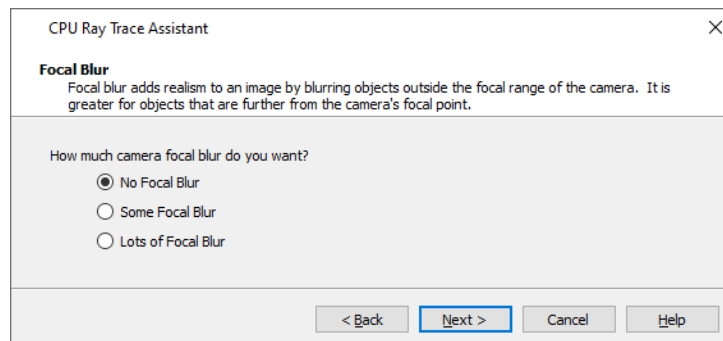

Specify the amount of focal blur to use in the ray trace. The options here correspond to the **F-Number** in the Ray Trace Options dialog. See [Advanced Panel on page 1174](#).

- Select **No Focal Blur** to disable Focal Blur when this option is used.
- Select **Some Focal Blur** to use an F-Number of 5.6.
- Select **Lots of Focal Blur** for to use an F-Number of 2.8.

## COMPLETING THE ASSISTANT

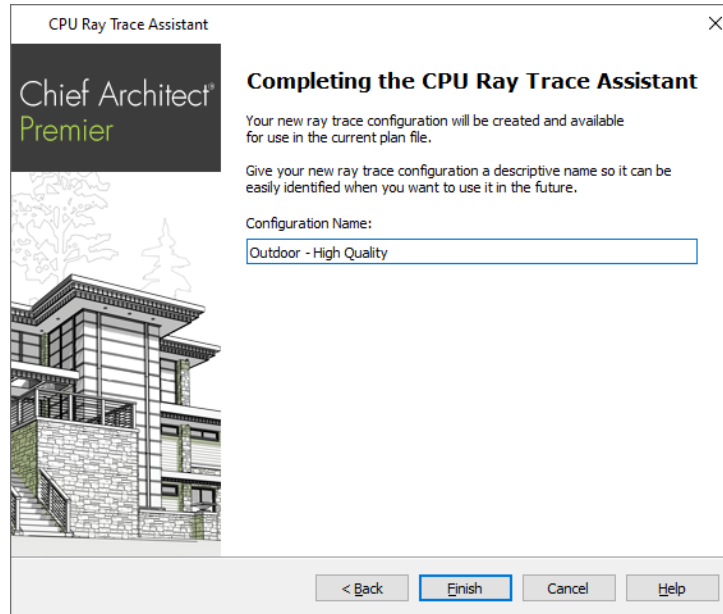

Specify a **Name** for the newly created ray trace configuration. This name will be listed in the CPU Ray Trace Current View/CPU Ray Trace Defaults dialogs, and can also be changed there. See *CPU Ray Trace Current View/CPU Ray Trace Defaults Dialog on page 1170*.

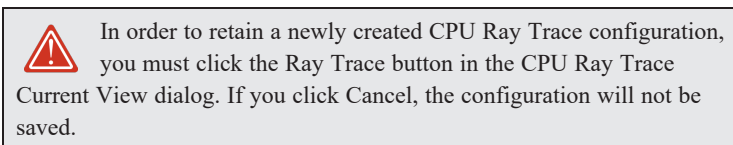

The initial name created by the program is based on the settings from the Welcome page. If you click the **Back** button and change these settings, this name will adjust as well, provided that you did not change it in any way.

Click **Finish** to create the new ray trace configuration and return to either the CPU Ray Trace Current View or Defaults dialog, where it will be selected as the Current Configuration.



## Adjusting Ray Trace Properties and Effects

A number of attributes of a CPU Ray Trace image can be adjusted while the view is being generated or after it is complete.

If **Save Image to File** is checked in the CPU Ray Trace Options dialog, the program will automatically save to the specified image file if changes are made to it using either the **Adjust Image Properties**  or **Adjust Effects**  tools and the ray trace view window is closed. See *General Panel on page 1171*.

### ADJUST IMAGE PROPERTIES

 Select **File> Adjust Image Properties** to open the Image Properties dialog. The settings in this dialog are the same as those in the CPU Ray Trace Options dialog, where their initial values are set. See *Image Properties Panel on page 1175*.

## ADJUST EFFECTS



Select **File > Adjust Effects** to open the Adjust Effects dialog.

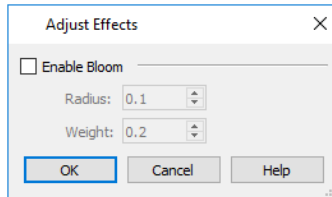

- Check **Enable Bloom** to enable the settings below. Bloom, or light bloom, can occur around areas of intense illumination and looks as though the light is ‘bleeding’ beyond the edges of the light source.
- Specify the **Radius**, which is the width of the bloom area beyond a light source. The higher the Radius setting, the longer the bloom calculation will take.
- Specify the **Weight**, which is the intensity or strength of the bloom effect.
- Click **OK** to close the dialog and apply your changes to the view. Depending on your settings, this could take some time. A progress indicator will display at the bottom of the window. You can press the Esc key to cancel the bloom operation at any time.

---

## CPU Ray Tracing Tips

CPU Ray Tracing gives you the ability to produce high quality, photo-realistic images of your model; however, it is also a resource intensive process that can be quite time-consuming. For best results, there are a number of variables to consider.

### CPU RAY TRACE CONFIGURATIONS

A CPU Ray Trace Configuration is a group of CPU Ray Trace Options settings saved in the current plan. You can create your own custom configurations for a variety of purposes. See [CPU Ray Trace Options on page 1171](#).

CPU Ray Trace Configurations can be saved in your template plans, saving you the effort of reproducing them for each new project. See [Template Files on page 87](#).

### CREATING THE CAMERA VIEW

To create a CPU Ray Trace image in Chief Architect, begin by creating a camera view or overview of the model. The camera position, field of view, and orientation determine the scene’s appearance in the ray trace window. See [Editing 3D Views on page 1105](#).

In order to run a CPU Ray Trace, either the Standard or Physically-Based Rendering Technique must be active and the **Hide Camera-Facing Exterior Walls**  setting must be toggled off. See [Standard Rendering on page 1150](#) and [Hide Camera-Facing Exterior Walls on page 1135](#).

CPU Ray Trace views can be created from both Orthographic and Perspective views; however, Perspective views appear more realistic to the human eye and are better suited to producing photo-realistic images. See [Perspective and Orthographic Views on page 1080](#).

Note: The generated 3D grass in Grass Regions does not display in CPU Ray Trace views. See [Terrain Features on page 1252](#).

## LIGHTING

Lighting is an extremely important aspect of high-quality ray trace views. For best results, be prepared to spend some time making adjustments to their positions and light data settings and consider adding light sources to your model. See [Lighting on page 1135](#).

In CPU ray trace views, all light sources that are turned “On” and have **Use in CPU Ray Tracing** checked in their specification dialog can contribute light to the scene. See [Light Data Panel on page 675](#).

To increase ray tracing speed, the program will identify any lights that do not contribute direct lighting to the scene when a CPU ray trace is preprocessing and will remove them from the ray trace lighting calculations.

You can create your own custom Light Sets for ray tracing and can specify which set to use in the CPU Ray Trace Options dialog. See [Lighting Panel on page 1172](#).

For light sources that cast shadows in a CPU Ray Trace scene, consider using the **Soft Shadows** option. Soft Shadows requires more ray tracing time, but smooths the appearance of shadows created by a light, improving their appearance. See [Light Data Panel on page 675](#).

Most other rendering settings, including those in the Preferences dialog, are not used for generating a CPU ray trace view, although Ambient Light, set in the 3D View Defaults dialog, is. See [3D View Defaults Dialog on page 1083](#).

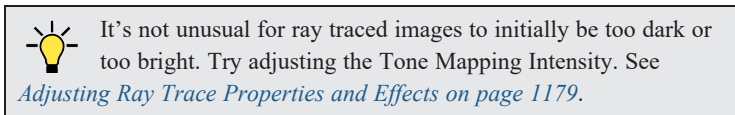

## MATERIAL DEFINITIONS

The attributes of the materials applied to objects in a scene have an extremely important effect on the final quality of any ray trace. These attributes can be adjusted in the Define Material dialog.

All of the attributes that affect a material's appearance in a Standard rendering will also affect its appearance in a ray trace. See [Texture Panel on page 1069](#).

In addition, a number of settings specifically affect ray traces. See [Properties Panel on page 1072](#).

One example is reflectivity. For example:

- For outdoor scenes, ensure that your windows are slightly reflective. You may want to set up a building across the street that, though not in the scene, appears in the reflections in the windows.
- In interior scenes, use partly reflective materials on objects such as stove tops, tile floors, and coffee pots.



## INTERIOR VIEWS

When creating an interior ray trace view in which sunlight shines through windows, bear these settings mind:

- To produce effective lighting in interior CPU ray traces, **Use Photon Mapping** needs to be checked. See [Advanced Panel on page 1174](#).
- For colored shadows created by light passing through colored semi-transparent objects, check **Compute Caustics** as well. See [Advanced Panel on page 1174](#).
- The **Direct Sunlight Intensity** setting for interior views should be set higher than for exterior views. A value of 5 is a good starting point, but you may wish to experiment. See [Lighting Panel on page 1172](#).
- When your CPU ray trace is finished and the ray trace window is active, select **File> Adjust Image Properties**  and adjust the **Brightness** value as needed. See [Adjust Image Properties on page 1179](#).

## NIGHTTIME VIEWS

For best results when creating a nighttime CPU ray trace view, there are a few considerations to bear in mind:

- While the rendered view you wish to ray trace is active, select **3D> Lighting> Toggle Sunlight**  to turn off the sun as a light source. See *Sunlight and Moonlight on page 1136*.
- Use the CPU Ray Trace Assistant to create an **Outdoor** ray trace configuration. Choose **Dark** or **Nighttime** as the outdoor conditions on the Environment Lighting page. See *CPU Ray Trace Assistant on page 1176*.
- When the new configuration is finished, click the **Edit** button in the CPU Ray Trace Options dialog and enable **Photon Mapping**. The **Use Caustics** option improves the quality of light shining through transparent objects. See *Advanced Panel on page 1174*.
- When your CPU Ray Trace is finished and its window is active, select **File> Adjust Image Properties**  and either lower the **Intensity** value or uncheck **Use Tone Mapping** to turn this feature off altogether. See *Adjust Image Properties on page 1179*.

## FASTER CPU RAY TRACING

Depending on the scene and the quality you want to achieve, a CPU Ray Trace can quite literally take days to produce. There are several things you can do to reduce the time required:

- Reduce the number of surfaces in the 3D model by turning off all layers not used in the scene to be ray traced. For example, you may be able to turn off terrain layers for interior views, or cabinet layers for exterior views. See *Layers on page 176*.
- An even more effective way to reduce the size and complexity of a 3D model is to use **Save As**  to create a copy of the plan, then delete all areas of the model that do not affect the scene to be ray traced. Depending on the scene, you may be able to delete entire rooms - or even entire floors.
- Image size is a significant factor in the speed of a CPU Ray Trace. As you adjust the lighting and other variables in a scene, you can save time by creating smaller ray traces for preview purposes. To do this, specify a relatively small image size in the CPU Ray Trace Options dialog. When you are ready to create a final CPU Ray Trace, specify a larger image size. See *General Panel on page 1171*.

## CPU USAGE

CPU Ray Tracing is a data intensive process that can require a lot of resources on any computer. You can specify whether Chief Architect or its CPU Ray Trace engine has access to more of your computer's processor resources when both are running in the Preferences dialog. See *Ray Trace Panel on page 125*.

## QUEUING CPU RAY TRACE JOBS

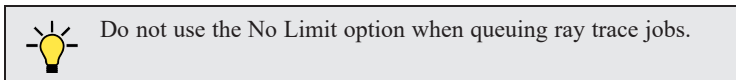

Because Chief Architect's CPU Ray Trace engine is a separate process from the program, you can set up a queue of multiple ray trace jobs, much like you can queue multiple print jobs for a printer.

CPU Ray Traces are generated one at a time, so in order for a queue of multiple ray traces to be completed, they must all use CPU Ray Trace Configurations set to use a defined period of time or number of passes. See *General Panel on page 1171*.



***To queue multiple CPU ray traces***

1. Start your first CPU Ray Trace and then return to plan view without closing the ray trace view window. See *Working in Multiple Views on page 150*.
2. Open or create the next camera view that you would like to ray trace.
3. Choose the desired CPU Ray Trace Configuration and begin the CPU Ray Trace.
4. Repeat these steps to queue as many CPU Ray Traces as you need. As soon as one finishes, the next one will begin.

If you have multiple ray traces queued and you **Pause**  the one in progress, the next job in queue will begin running. If you **Resume**  the first job, the one in progress will be paused.

You can work on other tasks on your computer while your CPU Ray Traces run, or you can walk away. You can lock your computer and even turn off the monitor; but do not exit out of Chief Architect or shut down the computer or your queue will be lost.

# Pictures, Images, and Walkthroughs

## Chapter 35

Chief Architect uses picture files in a variety of ways to enhance your drawings.

The Library Browser contains images of real world objects like plants and vehicles that can display in 3D views.

Picture files can also be imported into Chief Architect and shown in most views.

You can save any view using a variety of picture file formats. In addition, Chief Architect allows you to create virtual tour videos that can be played back later and shared with others.

Chief Architect can also generate CPU Ray Trace images from a Standard or Physically Based rendered view for photo-realistic rendering capabilities. CPU Ray Tracing is discussed in its own chapter. See *CPU Ray Tracing on page 1167*.

### TOPICS

<b>Picture Files vs Pictures and Image Objects</b> .....	<b>1185</b>
<b>Images</b> .....	<b>1185</b>
<b>Displaying Images</b> .....	<b>1186</b>
<b>Editing Images</b> .....	<b>1187</b>
<b>Image Specification Dialog</b> .....	<b>1188</b>
<b>Pictures</b> .....	<b>1191</b>
<b>Picture File Box Specification Dialog</b> .....	<b>1193</b>
<b>Metafiles</b> .....	<b>1195</b>
<b>Metafile Box Specification Dialog</b> .....	<b>1196</b>
<b>PDF Files</b> .....	<b>1198</b>
<b>PDF Box Specification Dialog</b> .....	<b>1199</b>
<b>Displaying Pictures, Metafiles, and PDF Boxes</b> .....	<b>1200</b>
<b>Editing Pictures, Metafiles, and PDF Boxes</b> .....	<b>1201</b>
<b>Creating Screen Captures</b> .....	<b>1203</b>
<b>3D Backdrops</b> .....	<b>1204</b>
<b>Backdrop Specification Dialog</b> .....	<b>1205</b>
<b>Walkthrough Paths</b> .....	<b>1207</b>
<b>Walkthrough Path Specification Dialog</b> .....	<b>1210</b>
<b>Walkthrough Previews</b> .....	<b>1212</b>
<b>Recording a Walkthrough</b> .....	<b>1215</b>
<b>Creating VRML Files</b> .....	<b>1219</b>



---

## Picture Files vs Pictures and Image Objects

In common computer language, picture files, pictures and images are more or less synonymous. In the Chief Architect environment, however, there are some notable differences between these terms.

In Chief Architect, a two dimensional image file such as a .bmp, .jpg, .gif, or .png is referred to as a picture file or an image file. Examples of these files are saved on most computers and can be opened in a variety of applications.

A Picture, on the other hand, is a file that has been imported into the program. Pictures can be imported into plan view, cross section/elevation views, CAD details, and layout pages. They are two-dimensional only and do not display in camera views or overviews.

An Image object is also based on a picture file, but it does display in both 2D and 3D views. Images have 3D width and height data associated with them, as well as a 2D symbol which displays in plan view.

Picture files have additional uses in Chief Architect, as well:

- Backdrops are picture files that display behind 3D views. See [3D Backdrops on page 1204](#).
- Textures are picture files that realistically represent materials in 3D views. See [About Materials on page 1050](#).

---

## Images

Images add realistic detail to 3D views without adding many surfaces to the model. For example, a tree image with a single surface can be used instead of a tree symbol with thousands, dramatically improving realism without compromising drawing time.

There are two types of Images in Chief Architect:



**Images** rotate so that they always face the camera in 3D views.



**Billboard Images** do not rotate to face the camera. An example of when this may be useful is an image of a trellis, which might look awkward when facing a camera from a side view.

### PLACING IMAGES





A selection of Images are available in the Library Browser. Select one and click in a plan view, camera view or overview to place it. See [Placing Library Objects on page 972](#).

### CREATING IMAGES

Custom Images can be added to the User Catalog in the library, as well as created in plan files. Chief Architect can use any image with a \*.bmp, \*.jpg, \*.png, \*.gif, or \*.tif extension.

Generally, .png files work best as Images because this format has good compression and allows for the Image to contain transparency information.

#### *To create an Image in plan view*

1. In plan view, select **Build> Image> Create Image**  or **Billboard Image**  to open the Image Specification dialog. See [Image Specification Dialog on page 1188](#).
2. On the IMAGE panel:

- Click the **Browse** button to select a picture file on your computer or enter the path to a valid picture file in the **Image File** field. If the file is not located in the Chief Architect Premier X15 Data folder, a copy of the file will be created at Chief Architect Premier X15 Data\Images\My Images and the Image object will reference that copy. See *Chief Architect Premier Data on page 37*.
  - Select a **2D Plan Symbol** from the drop-down list or click the **Library** button and select a CAD block or symbol from the library. The selected symbol represents the image in plan view. See *Image Panel on page 1188*.
  - Specify the **Size** and **Position** of the image.
3. Specify transparency information on the TRANSPARENCY panel.
  4. Click OK to close the Image Specification dialog.
  5. Click to place the new Image in plan view.

### ***To create an image in the Library Browser***

1. In the Library Browser, right-click on an unlocked folder.
2. Select **New> Image** from the contextual menu to open the Image Specification dialog.
3. Browse to the image file you want to add and select your other options. See *Image Specification Dialog on page 1188*.
4. Once created, the image is listed in the library folder that you right-clicked on. Size and other data is saved.

## **USING PASTE IMAGE**



You can also import an image by first copying it to the system clipboard, then navigating to a Chief Architect window and selecting **Edit> Paste> Paste**. See *Paste Special on page 171*.



The **Screen Capture** tool can also be used to create a custom image object. See *Creating Screen Captures on page 1203*.

## **CONVERTING A FOLDER OF IMAGES**



A folder of image files can be converted into Image objects and added to the library all at once, saving the effort of converting them individually.

### ***To convert a folder of images***

1. Select **Build> Image> Create Image Library** .
2. In the Select an Image Folder dialog, select a folder of image files to convert and click OK.
3. A new library with the same name and directory structure as the converted folder is listed in the Library Browser. Depending on the number of images in the folder, this may take a few moments.

---

# **Displaying Images**



The display of images in floor plan and 3D views is controlled in the Layer Display Options dialog. See *Layer Attributes on page 177*.

Images are placed on the “Images” layer by default but can be moved to other layers once they have been created. See *Image Specification Dialog on page 1188*.

## IN PLAN VIEW

In plan view, most images are represented by an Image  symbol. You can specify a different symbol to represent an image if you wish. See *Image Specification Dialog on page 1188*.

Any 2D CAD block from the library can represent an image object. If you do not see a CAD block that suits your needs, you can create one or import one from another application. See *Custom 2D Symbols on page 332*.

## IN 3D VIEWS

The actual picture associated with an image object can be seen in 3D views, as can any transparency data associated it. See *Image Specification Dialog on page 1188*.

Images can be set to either rotate so that they always face the camera or remain stationary, like billboards. See *Images on page 1185*.

## IN LAYOUT VIEWS

Images can be included in all views sent to layout with the exception of those using Plot Lines. See *Plot Line Views on page 1343*.

---

# Editing Images

Images can be selected in 2D and 3D views and edited using the edit handles, edit tools and the Image Specification dialog. See *Image Specification Dialog on page 1188*.

## USING THE EDIT HANDLES

In plan view, a selected image can be rotated, moved, and resized. In 3D views, a selected image only has two edit handles: the circular Resize handle and square Move handle.



When an image is resized using the edit handle, its aspect ratio is retained and 2D symbol resizes proportionally.

## USING THE EDIT TOOLBAR

A selected image or images can be edited in a variety of ways using the buttons on the Edit Toolbar. See *The Edit Toolbar on page 130*.

## USING DIMENSIONS



Image objects can be moved using dimensions in plan view. See *Moving Objects Using Dimensions on page 483*.

In order for a manually drawn Dimension Tool to locate image objects as a dimension line is drawn, it must be set to do so in the Dimension Defaults dialog. See *Locate Manual Panel on page 454*.

# Image Specification Dialog



Select an image and click the **Open Object** edit button to open the Image Specification dialog.

## IMAGE PANEL

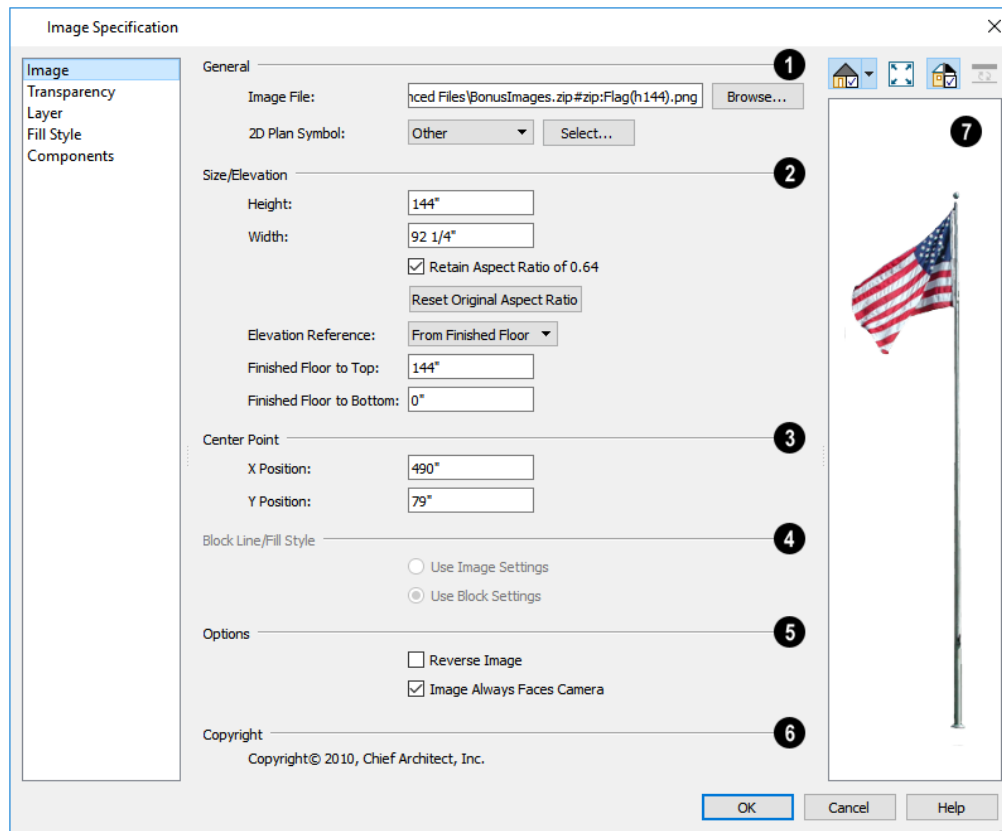

### 1 General

General information about the selected Image can be specified here.

- The **Image File** associated with the Image can be specified. Click **Browse** to choose a file saved on your computer or type the file's full pathname in the text field.
- Select a **2D Plan Symbol** from the drop-down list to represent the Image in plan view. See *Displaying Images on page 1186*.

- Click the **Select** button to choose a CAD block to act as the Image's 2D symbol either from the library or a list of CAD blocks in the current plan. See *Select Library Object Dialog on page 974* and *CAD Block Management on page 333*.

Note: Images cannot be assigned a 2D Plan Symbol that contains a nested CAD block. See *CAD Blocks on page 329*.

## 2 Size/Elevation

Specify the **Size/Elevation** of the image as it displays in 3D views.

- Enter a **Height** for the selected image.
- Enter a **Width** for the selected image.
- Uncheck **Retain Aspect Ratio of X** if you would like to modify the Height or Width without affecting the other value. If you do this, the image may appear distorted.  
This check box does not affect editing performed outside this dialog and is an action rather than a state: the next time you open this dialog, it will be checked.
- Click **Reset Original Aspect Ratio of** to reset the image's original aspect ratio and remove any distortion caused by resizing.
- Select the **Elevation Reference** from the drop-down list. This determines where the next two settings are measured from and also affects their setting labels.
- Specify the height **to Top**, measured from the selected Elevation Reference to the top edge of the image.
- Specify the height **to Bottom**, measured from the selected Elevation Reference to the bottom edge of the image.

## 3 Center Point

Specify the location of the **X and Y Coordinates** of the selected image's **Center Point**.

## 4 Block Line/Fill Style

Specify the appearance of the **Block Line/Fill Style** of the image's 2D symbol in plan view. Only available when a CAD block from the library is selected as the image's 2D Plan Symbol.

- Select **Use Image Settings** to use the image's line style, which is set by layer, and its fill style, which is None (Transparent).
- Select **Use Block Settings** to use the 2D CAD block's line and fill styles. See *Custom 2D Symbols on page 332*.

## 5 Options

Check **Reverse Image** to reflect the appearance of the image about an imaginary vertical line through its center.

Check **Image Always Faces Camera** to prevent the image from rotating to face the camera in 3D views. This box is unchecked for Billboard Images. See *Images on page 1185*.

## 6 Copyright

Any **Copyright** information associated with the selected Image will be stated here.

## 7 Preview

A preview of the selected Image displays here. The Glass House Rendering Techniques is not available for images. See [Dialog Preview Panes on page 22](#).

### TRANSPARENCY PANEL

The settings on the TRANSPARENCY panel let you specify portions of the selected image as transparent.

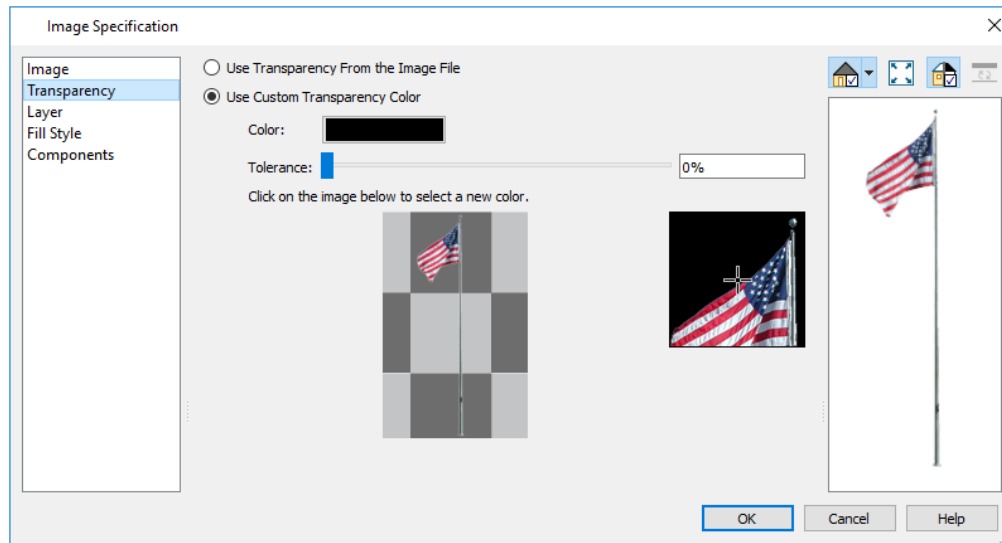

- Click the **Use Transparency From The Image File** radio button to use any transparency data included in the image file.
- Click the **Use Custom Transparency Color** radio button to specify a color in the image to represent the transparency and enable the settings below.
- Click the Color bar to select a color in the Select Color dialog. See [Color Chooser/Select Color Dialog on page 203](#).
- Use the slide bar or enter a value to specify a level of **Tolerance** to be applied to colors that are almost the same as the specified transparency color.
- Move your pointer over the small preview image below. The pointer changes to an eyedropper and a magnified preview displays to its right. Click to select the color of the pixel your pointer is over as the Transparency color. The selected color displays in the Color bar, below.
- A magnified preview of the area in the preview image above displays here, allowing for accurate pixel selection.

Note: The image preview will display its original orientation, even if Reverse Image is checked on the Image panel.

### THE TRANSPARENCY COLOR

If the portion of the image file that you wish to use contains the transparency color, that part of the image also becomes transparent. If this happens, the image may appear partially disintegrated.

You may need to experiment to find the best transparency color and tolerance for the image.

### LAYER PANEL

For information about the settings on this panel, see [Layer Panel on page 186](#).

## FILL STYLE PANEL

The settings on the FILL STYLE panel affect the appearance of the selected image's **2D Plan Symbol** in plan view, provided that the selected symbol is a closed shape. For information about these settings, see *Fill Style Panel and Dialogs on page 193*.

## COMPONENTS PANEL

The information on the COMPONENTS panel can be used in the materials list. For more information, see *Components Panel on page 1330*.

---

# Pictures

A variety of picture file types can be imported into and exported out of Chief Architect.

Metafiles are also types of picture files that can be imported and exported. See *Metafiles on page 1195*.

## EXPORTING PICTURES

There are several ways to save a picture of a view in Chief Architect:



Using the **Export Picture** tool is similar to creating a screen capture of everything in the current view window. Pictures can be saved in various file formats and used in other applications. **Export Picture** is best suited for rendered and CPU Ray Trace views. When exporting a line-based view, best results can be achieved by saving it as a metafile. See *To export a metafile on page 1195*.



Before exporting a GPU Ray Trace camera view, you may want to make sure that it is denoised and that the Coordinate Indicators are turned off. See *Denoising on page 1132* and *Coordinate System Indicators on page 145*.

The **Screen Capture** tools offer another way to create a picture file based on the current view. See *Creating Screen Captures on page 1203*.

The **Save Image to File** option in the CPU Ray Trace Options dialog automatically saves a completed CPU Ray Trace view as a picture file. See *General Panel on page 1171*.



The **Export 360 Panorama** tool creates a spherical panoramic image file. See *Export 360 Panorama on page 1238*.



Use the **Print Image** tool to either print or save the current view as a PDF file. See *Print Image Dialog on page 1383*.

### *To export a picture*

1. Open the view that you would like to export as a picture file.
2. Zoom, pan or otherwise adjust the view so that what you see on screen suits your needs. See *Displaying 3D Views on page 1097*.
3. Select **File> Export> Export Picture (BMP, JPG, PNG)**  to open the Export Picture dialog, below, and specify the desired image size and other properties.

- In the Export Picture File dialog, which opens next, give the new picture file a name, file type, and save location. See *Exporting Files on page 41*.

## EXPORT PICTURE DIALOG

The settings in this dialog are retained between program sessions.

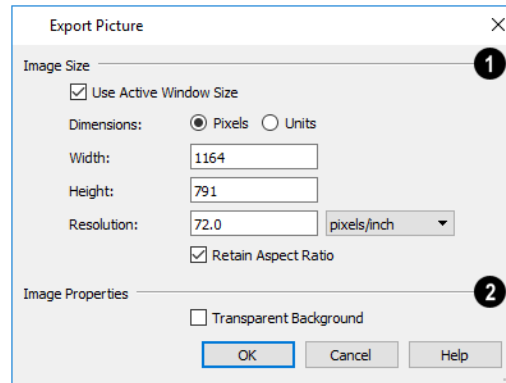

### 1 Image Size

Specify the exported file's **Image Size** in pixels or inches (mm).

- Check **Use Active Window Size** to export the picture at the same size as the active view window. The window's Width and Height are described below. In camera views only, these values can be changed, in which case this box becomes unchecked automatically.
- Select either **Pixels** or **Units** as the method by which the picture's dimensions are measured.
- Specify the **Width** and **Height** of the image. The initial values correspond to the view window's size. In plan view and CAD Details, they display for reference only.
- Specify the **Resolution** of the image. Select **Dots/Inch** or **Dots/mm** from the drop-down list.
- Uncheck **Retain Aspect Ratio** if you would like to modify the Height or Width without affecting the other value. Leave this box checked to prevent the image from becoming distorted.

### 2 Image Properties

Check **Transparent Background** to produce alpha transparency in the spaces between all objects that can be seen in the current view. Transparency associated with Fill and Text Styles is retained, as well. Note that the **.png** and **.png** file types support transparency, while the **.jpg** and **.bmp** file types do not.

When you click OK, the Export Picture File dialog will open, allowing you to specify a name, file type, and save location for the picture file.

## IMPORTING PICTURES



Pictures can be imported into and displayed in plan view, cross section/elevation views, CAD Details, and layout pages. Pictures do not display in camera views or overviews. See *Displaying Pictures, Metafiles, and PDF Boxes on page 1200*.

There are several ways to import a Picture into Chief Architect:



- Select **File> Import> Import Picture (BMP, JPG, PNG)** to open the Import Picture File dialog, which is a typical open file dialog. See *Importing Files on page 45*.
- Click and drag an image file from an operating system window into the Chief Architect window.
- In any application, copy an image to the system clipboard, then select **Edit> Paste> Paste Special**  from the program menu in an eligible view window. See *Paste Special on page 171*.
- Use the Screen Capture tools. See *Creating Screen Captures on page 1203*.

Note: Importing large, or multiple, Pictures into a plan or layout file can result in program slowness.

An imported picture is placed in the center of the current view. Once imported, pictures can be selected and edited. See *Editing Pictures, Metafiles, and PDF Boxes on page 1201*.

If the file referenced by a picture object is modified outside Chief Architect, its appearance will not update in Chief Architect until you close and reopen the plan or layout file it was imported into.

## Picture File Box Specification Dialog

 Select an imported picture file and click the **Open Object** edit button to open the Picture File Box Specification dialog.

### GENERAL PANEL

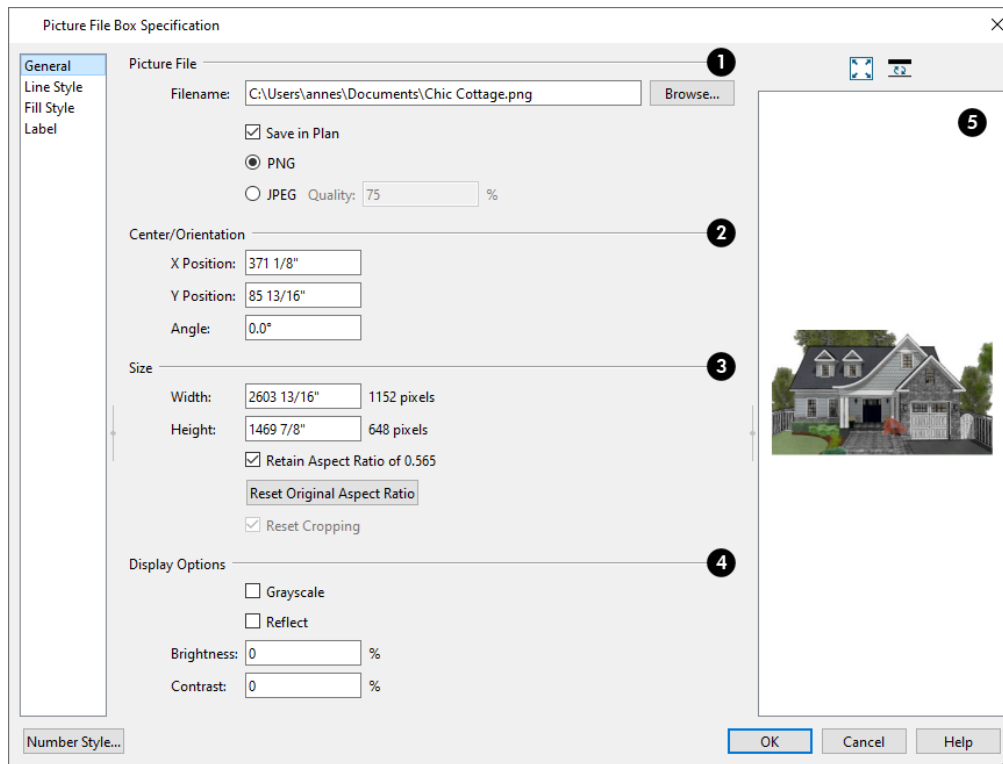

#### **1** Picture File

Information about the selected **Picture File** can be specified here.

- The **Filename** of the picture file displays here. You can type a new pathname in the text field to change the picture assigned to this box if you wish. If the selected picture box is not linked to a file saved on the system, a Warning icon will display in the text field.
- Click the **Browse** button to choose a new picture file or to relink to a missing file.
- Check **Save in Plan** to embed the picture in the plan or layout file. If a picture file is embedded, it does not need to be linked to a file on the system and you do not need to include it when sending the plan or layout to a different computer.
- Click the radio button beside either **PNG** or **JPEG** to specify how to save the embedded picture data.
- Specify the picture's **Quality %** when **JPEG** is selected. A lower value results in better compression, while a higher value reduces data loss.

Note: PNG is the better option for pictures of line drawings, text, or large areas of a single color. In addition, PNG files support alpha channel transparency. JPEG is the better option for photos.

## 2 Center/Orientation

Specify the position of the selected Picture's center point and its angle. See [3D Drafting on page 13](#).

- Specify the **X** and **Y Positions** of the picture box's center point relative to the absolute origin.
- Specify the **Angle** of the picture box relative to a horizontal line pointing towards the right-hand side of the screen.

## 3 Size

Specify the **Size** of the picture in plan inches (mm).

- Specify the **Width** of the picture box. The original width in pixels displays to the right.
- Specify the **Height** of the picture box. The original height in pixels displays to the right.
- Uncheck **Retain Aspect Ratio of X** if you would like to modify the Height or Width without affecting the other value. If you do this, the picture may appear distorted. This check box does not affect editing performed outside this dialog and is an action rather than a state: the next time you open this dialog, it will be checked.
- **Reset Original Aspect Ratio** - If the aspect ratio is changed, you can click this button to return the picture to its original aspect ratio.
- Check **Reset Cropping** to fill the extents of the selected Picture box with the image associated with it. If the box has been resized, the image may appear distorted. See [Editing Pictures, Metafiles, and PDF Boxes on page 1201](#).

## 4 Display Options

A variety of **Display Options** are available.

- Check **Grayscale** to replace the color in the selected picture with shades of gray.
- Check **Reflect** to reverse the image.
- Enter a degree of **Brightness** from 1 - 100%.
- Enter a degree of **Contrast** from 1 - 100%.

## 5 Preview

A preview of the selected Picture displays here. See [Dialog Preview Panes on page 22](#).

## LINE STYLE PANEL

The settings on this panel are similar to those on the LINE STYLE panel in numerous other dialogs, with one exception: check **Show Outline** to turn on the display of the picture's border polyline. For more information, see [Line Style Panel on page 305](#).

## FILL STYLE PANEL

For information about using the FILL STYLE panel, see [Fill Style Panel and Dialogs on page 193](#).

## LABEL PANEL

Picture box labels display when the "Picture/PDF Boxes, Labels" layer is turned on and use the Text Style assigned to that layer. The Automatic Label for Pictures is blank, but you can specify a custom label. For information about the settings on this panel, see [Label Panel on page 700](#).

---

# Metafiles

A metafile (**.emf**, **.wmf**) is a special picture file format made up of vectors (lines) that allow the image to be rescaled without loss of quality. High resolution pictures of line-based views can be exported as a metafile.



Note: Metafiles are not supported in Mac operating systems and cannot be imported or exported in Mac versions of the software.

## EXPORTING METAFILES

 An enhanced metafile (**.emf**) can be exported from any line-based view: that is, from plan view, CAD Details, layout pages, and 3D Vector Views.

Only objects that display on screen are included in an exported metafile.

### *To export a metafile*

1. Accurately position the view on screen.
2. Select **File> Export> Export Metafile (EMF)** .
3. Drag a marquee  from corner to corner, defining the area to be included in the metafile.
4. Release the mouse button to open the Export Metafile dialog, which is a typical Save File dialog. See [Exporting Files on page 41](#).
5. When you click the Save button, the Metafile Size dialog opens.

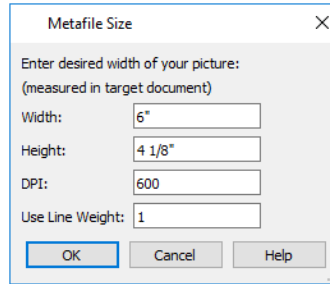

- Specify the desired **Width** or **Height** of the metafile. When one value is edited, the other changes to maintain its aspect ratio.

Specify, too, the desired **Dots Per Inch (DPI)** for the metafile. A larger value results in a higher quality metafile, but also a larger file size.

- When a metafile is exported from a 3D Vector View, you can also specify the printed thickness of lines in the view. To increase the printing line weight, type a larger number in the **Use Line Weight** field. See *Vector View on page 1150*.

Metafiles exported from plan view use the line weights defined in the Layer Display Options dialog. See *Layer Display Options Dialog on page 179*.

## IMPORTING METAFILES

 Metafiles can be imported into and displayed in plan view, cross section/elevation views, CAD Details, and layout pages. Metafiles do not display in camera views or overviews. See *Displaying Pictures, Metafiles, and PDF Boxes on page 1200*.

There are two ways to import a metafile into Chief Architect:

- Select **File > Import > Import Metafile (EMF, WMF)**  to open the Import Metafile dialog, which is a typical open file dialog. See *Importing Files on page 45*.
- You can also click and drag a metafile file from an operating system window into the Chief Architect window to import it.

An imported metafile is placed in the center of the current view. Once imported, metafiles can be selected and edited. See *Editing Pictures, Metafiles, and PDF Boxes on page 1201*.

---

## Metafile Box Specification Dialog

 Select an imported metafile and click the **Open Object** edit button to open the Metafile Box Specification dialog.

## GENERAL PANEL

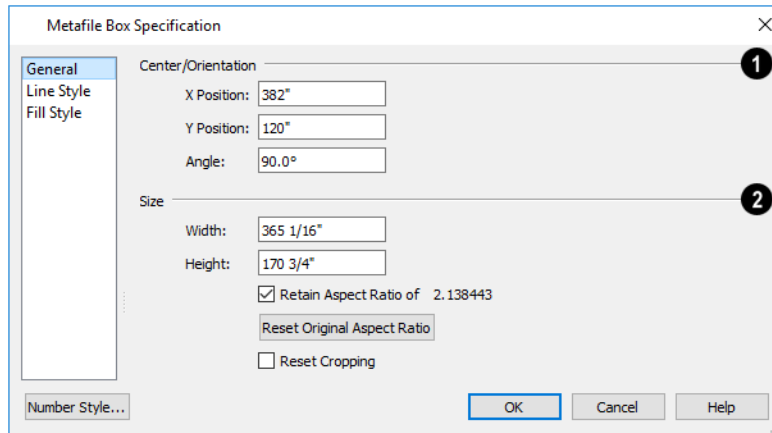

### 1 Center/Orientation

Specify the position of the selected metafile's center point and its angle. See *The Chief Architect Premier Environment on page 12*.

- Specify the **X** and **Y Position** relative to the absolute origin.
- Specify the **Angle** of the metafile box relative to a horizontal line pointing towards the right-hand side of the screen.

### 2 Size

Specify the **Size** of the metafile in plan inches (mm).

- Specify the **Width** of the metafile box.
- Specify the **Height** of the metafile box.
- Uncheck **Retain Aspect Ratio of X** if you would like to modify the Height or Width without affecting the other value. If you do this, the metafile may appear distorted.  
This check box does not affect editing performed outside this dialog and is an action rather than a state: the next time you open this dialog, it will be checked.
- **Reset Original Aspect Ratio** - If the aspect ratio is changed, you can click this button to return the picture to its original aspect ratio.
- Check **Reset Cropping** to fill the extents of the selected metafile box with the image associated with it. If the box has been resized, the image may appear distorted. See *Editing Pictures, Metafiles, and PDF Boxes on page 1201*.

## LINE STYLE PANEL

The settings on this panel are similar to those on the LINE STYLE panel in numerous other dialogs, with one exception. Check **Show Outline** to turn on the display of the picture's border polyline. For more information, see *Line Style Panel on page 305*.

## FILL STYLE PANEL

For information about using the FILL STYLE panel, see *Fill Style Panel and Dialogs on page 193*.

## PDF Files

Portable Document Format (.pdf) files are a special type of file that can be viewed on nearly any computer and can include a wide variety of visual information.

### PRINTING AND EXPORTING PDF FILES

 You can save any view as a 2D .pdf file by selecting **File> Export> Export PDF**. This will open either the Print View or Print Image dialog, depending on the view type.

You can also save any view as a 2D .pdf file by selecting “Chief Architect Save as PDF” as the Destination printer **Name** in either of these dialogs. See [Printing to a PDF File on page 1374](#).

### IMPORTING PDF FILES

 To import a .pdf file, select **File> Import> Import PDF**. You can also import a .pdf file by dragging it from an operating system window into the Chief Architect window.

You can import .pdf files into Chief Architect in plan view, cross section/elevation views, CAD Details, and in layout. Once imported, PDF boxes behave and can be edited similar to imported pictures and metafiles. See [Editing Pictures, Metafiles, and PDF Boxes on page 1201](#).

Some .pdf files can contain both 2D and 3D information; however, Chief Architect can only support 2D data in an imported .pdf file. When a 3D .pdf file is imported, it may display text, a static image of the 3D model, or it may not import at all.

Note: Importing large, or multiple, .pdf files into a plan or layout file can result in program slowness.

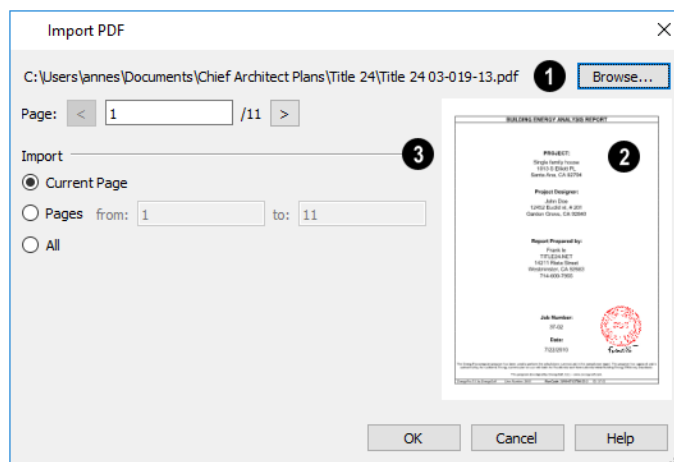

**1** The full pathname of the .pdf file displays here. If the pathname is not that of a valid .pdf file, this text will display in red.

- Click the **Browse** button to choose a new .pdf file or to relink to a missing file.
- Specify the **Page** of the .pdf file that displays in the preview on the right. Type a page number in the text field or use the spin control arrows to browse the pages sequentially.

**2 Preview**

A preview of the page selected above displays on the right.

### 3 Import

Specify how much of the **.pdf** file you wish to **Import**. When multiple pages are imported, a separate PDF box is created for each one.

- Select **Current Page** to import only the page specified above and shown in the preview to the right.
- Select **Pages**, then specify the starting page in the **From** field and the ending page in the **To** field.
- Select **All** to import the entire **.pdf** file.

## PDF Box Specification Dialog

Select an imported PDF box and click the **Open Object** edit button to open the PDF Box Specification dialog.

### GENERAL PANEL

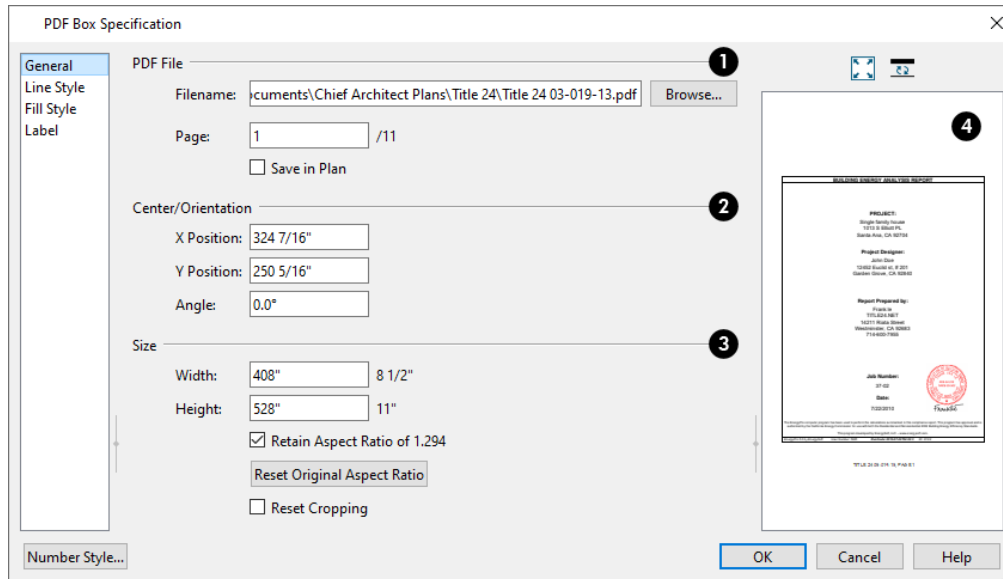

### 1 PDF File

The full **Filename** of the **.pdf** file displays here. Type a new name to associate the selected PDF box with a different **.pdf** file.

- Click the **Browse** button to choose a new **.pdf** file or to relink to a missing file.
- Specify the **Page** of the **.pdf** file that displays in the selected PDF box.
- Check **Save in Plan** to embed the **.pdf** in the plan or layout file. If a **.pdf** is embedded in a file, you do not need to include it when sending the file to a different computer. If the **.pdf** file is modified, however, the PDF box in Chief Architect will only update automatically if this is unchecked.

### 2 Center/Orientation

Specify the position of the selected PDF box's center point and its angle. See *3D Drafting on page 13*.

- Specify the **X and Y Positions** of the PDF box's center point relative to the absolute origin.
- Specify the **Angle** of the PDF box relative to an imaginary horizontal line pointing towards the right-hand side of the view window.

### 3 Size

Specify the **Size** of the PDF box in plan inches (mm).

- Specify the **Width** of the PDF box.
- Specify the **Height** of the PDF box.
- Uncheck **Retain Aspect Ratio of X** if you would like to modify the Height or Width without affecting the other value. If you do this, the PDF box may appear distorted.  
This check box does not affect editing performed outside this dialog and is an action rather than a state: the next time you open this dialog, it will be checked.
- **Reset Original Aspect Ratio** - If the aspect ratio is changed, you can click this button to return the picture to its original aspect ratio.
- Check **Reset Cropping** to fill the extents of the selected PDF box with the image associated with it. If the box has been resized, the image may appear distorted. See *Editing Pictures, Metafiles, and PDF Boxes on page 1201*.

## LINE STYLE PANEL

The settings on this panel are similar to those on the LINE STYLE panel in numerous other dialogs, with one exception: Check the **Show Outline** box to turn on the display of the PDF box's border polyline.

See *Line Style Panel on page 305*.

## FILL STYLE PANEL

For information about using the FILL STYLE panel, see *Fill Style Panel and Dialogs on page 193*.

## LABEL PANEL

PDF box labels display when the "Picture/PDF Boxes, Labels" layer is turned on and use the Text Style assigned to that layer. The Automatic Label for PDF boxes reports its file name and the page number shown, but you can specify a custom label if you wish. For information about the settings on this panel, see *Label Panel on page 700*.

---

# Displaying Pictures, Metafiles, and PDF Boxes



The display of Pictures, Metafiles, and PDF Boxes is controlled in the Layer Display Options dialog. See *Layer Attributes on page 177*.

Pictures, Metafiles, and PDF Boxes are placed on the "Picture/PDF Boxes" layer by default; but once imported, they can be moved to other layers. See *Line Style Panel on page 305*.

Pictures, Metafiles, and PDF Boxes can be imported into and displayed in plan view, cross section/elevation views, CAD Details, and layout pages. A Picture, Metafile, or PDF Box can only be seen in the view where it was imported and cannot be imported into a camera view or overview.



## DRAWING GROUPS

Each object in a plan or layout file is included in a Drawing Group, which influences whether it displays in front of or behind other objects. By default, imported pictures and PDF Boxes are placed in Drawing Group 38, the Back Group, and imported metafiles are placed in Drawing Group 21, the same Drawing Group as CAD objects.

Once imported, the drawing order of pictures, metafiles, and PDF Boxes can be customized. See [Drawing Groups on page 190](#).

## IN LAYOUT

Pictures, metafiles, and PDF boxes are included when a view is sent to layout, and can also be imported directly onto a layout page. See [Pictures, Metafiles, and PDFs in Layout on page 1338](#).

---

# Editing Pictures, Metafiles, and PDF Boxes

Pictures, Metafiles, and PDF Boxes can be selected and edited using the edit handles, the Edit Toolbar, and their specification dialogs.

Imported pictures, metafiles, and PDFs are placed on the Current CAD Layer by default; but once imported, these objects can be placed on any layer. See [Layers on page 176](#).

## IN THE SPECIFICATION DIALOG

Pictures, Metafiles, and PDF Boxes can be customized in their specification dialog. See:

## USING THE EDIT HANDLES

Pictures, Metafiles, and PDF Boxes have edit handles similar to other box-based objects. See [Editing Box-Based Objects on page 232](#).

- The corner Resize handles do not behave the same for Pictures, Metafiles, and PDF Boxes as they do for CAD boxes, however. If you drag a corner handle of one of these objects while the Default Edit Behavior is active, its contents will resize and height to width ratio will be retained.
- If you drag an Extend handle along a Picture, Metafile, or PDF Box's edge, the contents of the box will not be resized. If you resize it larger, an empty space will be created between that edge and the contents; if you resize it smaller, the contents will be cropped.

## USING DIMENSIONS

Pictures, Metafiles, and PDF Boxes can be relocated relative to other objects with precision using dimensions.

To avoid changing the selected object's aspect ratio, make sure you choose to move the entire object rather than the selected edge. See [Moving Objects Using Dimensions on page 483](#).

## USING THE EDIT TOOLS



A selected Picture, Metafile, or PDF Box can be edited in a variety of ways using the buttons on the Edit Toolbar. See [The Edit Toolbar on page 130](#).

## POINT TO POINT RESIZE



A selected picture, metafile, or PDF box can be resized in either the X or Y direction with the **Point to Point Resize** edit tool.

### *To use the Point to Point Resize tool*

1. Select a picture box, metafile box, or PDF box.
2. Click the **Point to Point Resize**  edit button. When you move the mouse pointer into the drawing area, it displays the Point A  icon.
3. Click on the first of two points in the selected object's area that have a known distance between them.
4. Notice:
  - A temporary CAD point is created at the point where you clicked.
  - The mouse pointer now displays the Point B  icon.
  - As you move the mouse pointer, an extension line extends either horizontally or vertically from Point A.
5. Click on the second of the two points with a known distance between them.
  - Regardless of where the mouse pointer is positioned, Point B will be at the end of the extension line so for best results Points A and B should be on the same X or Y plane.
6. After you click on the second point, the Point to Point Resize dialog opens.

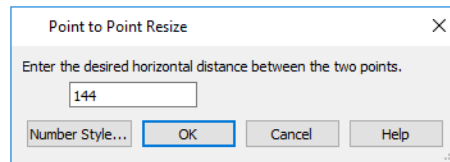

7. The current distance between the two points populates the text field. Enter a new dimension that matches the desired distance between the points.
8. When **Retain Aspect Ratio** is checked, the ratio between the selected object's height and width is maintained when you click OK and the object is resized. When this is unchecked, the object may become distorted-looking. If the selected object has been rotated, this box will be disabled and its aspect ratio will be retained.
9. Click **OK** to resize the picture, metafile, or pdf.

## RESIZE FACTOR

With a bit of calculation, an imported picture, metafile, or PDF box can be resized to scale using the Transform/Replicate Object dialog. Once resized, the information in the object box can be traced using Chief Architect's drawing tools and then deleted.

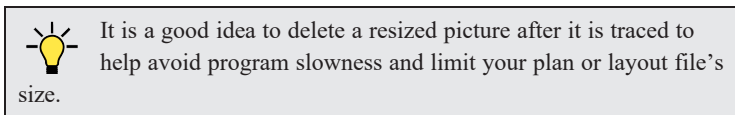

### ***To calculate the Resize Factor***

1. Find two items in the imported object that are separated by a known horizontal or vertical distance, such as two walls or plot lines.
2. Draw parallel CAD lines on top of these two items. See *The CAD Drawing Tools on page 295*.
3. Find the distance between the CAD lines. See *The Manually Drawn Dimension Tools on page 469*.
4. The Resize Factor for the image is the distance described in the picture divided by the distance between the CAD lines.

For example, if the items are supposed to be 10 feet apart on the picture, but the distance between the two CAD lines drawn on them is only 2 feet, you need to set the Resize Factor for the picture to 5. (10' divided by 2' equals 5). When the picture is 5 times the original size, the items on the picture are at the actual scale shown on the picture.

5. Select the picture and click the **Transform/Replicate Object**  edit button.
6. In the Transform/Replicate Object dialog, select the **Resize Factor** check box.
7. Enter the Resize Factor calculated above, then click **OK**.

---

## Creating Screen Captures



Use the **Screen Capture** tools to add images, backdrops, or materials to the Chief Architect Library or to create picture objects. You can capture screens in Chief Architect or other applications.

Begin by selecting **Tools > Screen Capture > Screen Capture Setup**  to open the Screen Capture Setup dialog.

### SCREEN CAPTURE SETUP DIALOG

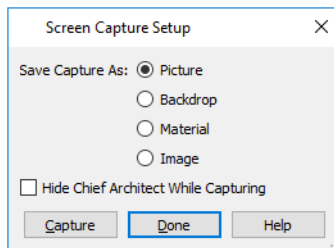

**Save Capture As** - Specify in what form you would like the screen capture to be saved.

- Select **Backdrop** to add the image to a new 3D backdrop in the User Catalog in the library, where it will be selected. See *3D Backdrops on page 1204*.
- Select **Image** to add the image to an Image object in the User Catalog in the library, where it will be selected. See *Images on page 1185*.
- Select **Material** to add the image to a new Stretch to Fit material in the User Catalog in the library, where it will be selected. See *Creating Materials on page 1060*.
- Select **Picture** to display the picture in the current plan, cross section/elevation, or CAD Detail view. See *Pictures on page 1191*.
- Check **Hide Chief Architect While Capturing** to minimize the program window so you can capture an image in another application.
- Click **Capture** to proceed with a screen capture and click **Done** when you are finished. The Screen Capture Setup settings are saved between program sessions and are used in all files.



On some systems, you must grant permission for Chief Architect Premier X15 to record the screen.

### ***To create a screen capture***

1. Select **Tools> Screen Capture> Capture Screen** , or click the **Capture** button in the Screen Capture Setup dialog.
2. The mouse pointer displays a crosshairs icon when the **Screen Capture** tool is active. Move it to the window that you want to capture from. This can be in Chief Architect, a web page, or another program.
3. Click and drag a rectangular marquee to capture the area within the marquee.
4. A captured Picture will be placed immediately in the Chief Architect drawing area. Captured Backdrops, Materials, and Images are saved in the User Catalog of the Library Browser.

Items added to the User Catalog are given names with a unique date and time stamp and reference image files of the same name saved in the Chief Architect Data folder. See [Chief Architect Premier Data on page 37](#).

To change the name of a captured backdrop, image, or material, right-click on its name in the library list, select **Rename**, and type in the new name. To avoid name conflicts, names should be unique. See [Renaming Library Items on page 968](#).

---

## **3D Backdrops**

A backdrop is an image, typically of an exterior view, that displays in the background of 3D views to help place the model into a realistic setting and add a sense of perspective.



Backdrops automatically adjust to fit each view window, so they look best when they are created with a height to width ratio that is similar to the window you are working in.



You can create digital photos of a building site for use as a backdrop.

### **SPECIFYING A BACKDROP IMAGE**

Backdrop images are view specific. You can select a backdrop image for a camera view from the library in either of two ways:

- In a 3D view, open the Library Browser. Select a Backdrop image, then move your mouse pointer  into the view window. Click anywhere in the view to apply the selected backdrop.
- Open the Camera Specification dialog, and on the BACKDROP panel, click the **Select Backdrop** button. See [Backdrop Panel on page 1122](#).

When a backdrop image is not applied, Chief Architect applies a background color instead. This color can be specified on the BACKDROP panel of the Camera Specification dialog, as well.

## SPHERICAL PANORAMIC BACKDROPS

Spherical Panoramic Backdrops are a special type of backdrop that wraps around the model in Perspective 3D views as though it were applied to a sphere surrounding it. It takes an image processing program or special camera to generate spherical panoramic backdrops.

If you have such a file, you can specify it as your Backdrop image, then check **Spherical Panoramic Backdrop** in the camera's specification dialog.

The **Use Generated Sky** option produces a special Spherical Panoramic Backdrop that simulates a daytime sky using the Generic Sun or active **Sun Angle**  data. See [Sun Angles and Shadows on page 1143](#).

Note: Spherical Panoramic Backdrops, including the Generated Sky, are not available in Orthographic Overviews.

## BACKDROP DEFAULTS

By default, Chief Architect uses backdrop images in Perspective Full Cameras only. You can, however, specify which types of views use backdrops by default, and also select the default backdrop images for each, in the Camera Tools Defaults dialogs. See [Camera Defaults Dialogs on page 1081](#).

Similarly, backdrop images are only used by default in a few Rendering Techniques: Standard, Watercolor, and Physically Based. You can choose whether a backdrop is used in any technique in the Rendering Technique Options dialog. See [Rendering Technique Options on page 1153](#).

## ADDING NEW BACKDROPS

A new backdrop image can be created using a variety of graphic file formats and can be imported into Chief Architect in several ways:

- Select **File> Import> Backdrop**  to open the Import Backdrop File dialog, which is similar to the Import Picture File dialog. See [Importing Pictures on page 1192](#).
- Right-click on the User Catalog and select **New> Backdrop** from the contextual menu.
- Copy and paste an image into Chief Architect. See [Copying and Pasting Objects on page 167](#).
- Use the **Screen Capture** tools. See [Creating Screen Captures on page 1203](#).
- Import a folder of backdrop images.

### *To add a folder of backdrops to the library*

1. Select **File> Import> Create Backdrop Library** .
2. Browse to the location of a folder of images on your hard drive that you would like to bring into the library as backdrops, select it, and click OK.
3. A folder with the same name will be created in the User Catalog, containing the imported backdrop images.

---

## Backdrop Specification Dialog



To open the Backdrop Specification dialog, select **File> Import> Import Backdrop** or right-click on the User Catalog in the Library Browser and select **New> Backdrop** from the contextual menu. See [Adding New Backdrops](#)

on page 1205.

You can also open this dialog by right-clicking on a backdrop image in the User Catalog in the Library Browser and selecting **Open**  from the contextual menu.

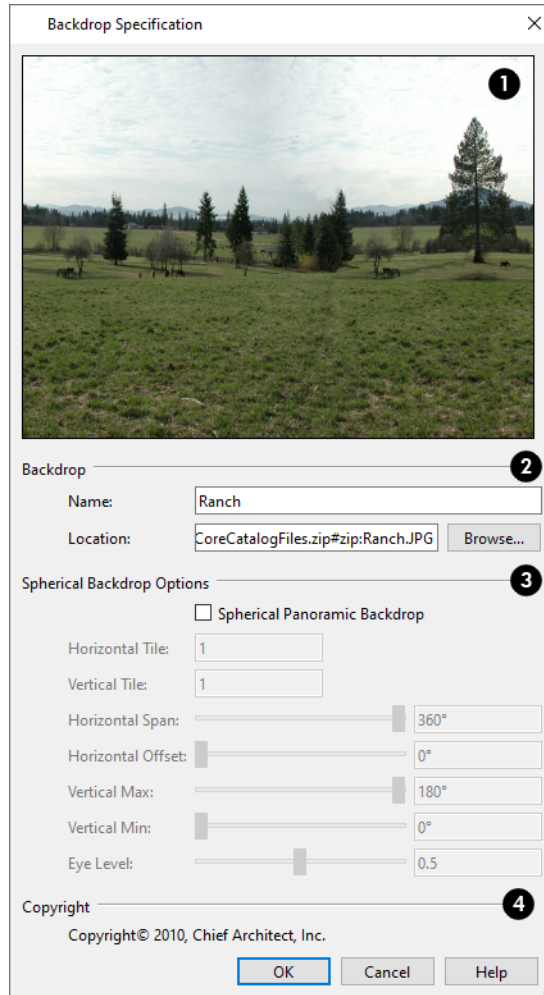

### 1 Preview

A preview of the selected image displays here.

### 2 Backdrop

Specify backdrop's Name and the image file associated with it.

- Type a **Name** for the selected backdrop, to be used in the Library Browser and 3D View Defaults dialog.
- In the **Location** field, type the full pathname of the image file or click the **Browse** button and browse to the file on your computer. If the file is not located in the Chief Architect Premier X15 Data folder, a copy of the file will be created at Chief Architect Premier X15 Data\Backdrops\My Backdrops and the program will reference that copy. See *Chief Architect Premier Data* on page 37.

### 3 Spherical Backdrop Options

A backdrop should only be specified as a Spherical Panoramic Backdrop if its image file was specially created for this

purpose.

- Check **Spherical Panoramic Backdrop** to place the selected backdrop onto a sphere that surrounds the model in the current view.
- **Horizontal Tile** - Specify how many times to tile the selected backdrop image side by side.
- **Vertical Tile** - Specify how many times to stack the selected backdrop image one above the other.
- Specify the **Horizontal Span**, which is how much of the sphere the backdrop is applied to. A Span of 360° wraps the entire sphere.
- Specify the **Horizontal Offset**, in degrees, to shift the backdrop image or tiled images in a clockwise direction.
- Specify the **Vertical Max**, which is the height of the bottom of the backdrop, measured relative to the top of the sphere.
- Specify the **Vertical Min**, which is the height of the bottom of the backdrop, measured relative to the bottom of the sphere.
- The **Eye Level** setting controls the vertical position of the camera within the sphere. A value of 0 positions the camera at the bottom of the sphere while a value of 1 positions it at the top. The default value is 0.5., which centers the camera inside the sphere.

Some experimenting with the **Angle** values may be necessary to achieve the desired results. You may prefer to do this after adding the backdrop to a plan. See [Backdrop Panel on page 1122](#).

#### Copyright

If the selected image has a **Copyright**, information about it will display here.

---

## Walkthrough Paths

 A 3D Walkthrough is a series of pictures saved as an **.mp4**, **.wmv**, or **.avi** file that can be played as a video by media player applications. Although you can record a walkthrough video directly from a camera view, Walkthrough Paths offer more options and flexibility and are the preferred way to create a walkthrough video in Chief Architect.





### CREATING WALKTHROUGH PATHS

There are two ways to create a Walkthrough Path:

 The **Create Walkthrough Path** tool allows you to define the route that a walkthrough video travels through a plan as well as specify details like camera height, angle, and speed before actually recording.

 Available in plan view, the **Create Orbital Walkthrough Path** edit tool creates a circular walkthrough path around a selected full overview or camera's focal point. The path's radius is equal to the length of the camera's line of sight, and all frames are pointed at the camera's focal point. **3D> Walkthroughs> Create Orbital Walkthrough Path** is also an option when a camera view or overview is active.

### ***To use the Create Walkthrough Path tool***

1. Begin by choosing a codec for recording walkthroughs. See [Selecting a Codec on page 1219](#).
2. Make sure that **Connect CAD Segments**  is enabled so multiple spline segments can snap together. See [Connect CAD Segments on page 159](#).
3. In plan view, select **3D> Walkthroughs> Create Walkthrough Path** , then click and drag to draw a Walkthrough Path. See [To use the Spline tool on page 324](#).
4. Edit the direction and curvature of the spline's segments, as needed. See [Editing Spline-Based Objects on page 235](#).
5. Add **Key Frames**  to the path and modify their specifications. See [Key Frames on page 1208](#).
6. Select the path and click the **Record Walkthrough Along Path**  edit button. See [Record Walkthrough Along Path on page 1215](#).

 Walkthrough Paths can follow stairs and ramps to span multiple floors. See [Walkthrough Paths and Stairs on page 1209](#).

In plan view, you can convert a CAD polyline or spline into a Walkthrough Path. See [Convert Polyline on page 262](#).

## **DISPLAYING AND EDITING WALKTHROUGH PATHS**

Walkthrough Paths display in plan view only and are located on the “Walkthrough Paths” layer by default. Walkthrough Paths display in front of most other objects, will print, and are included in views sent to layout or exported to **.dxf/.dwg**. See [Layers on page 176](#).

Before a Walkthrough Path can be edited, it must be selected. The Key Frame closest to the point where you clicked will be the Selected Key Frame. See [Selecting Objects on page 210](#).

Walkthrough Paths can be edited like other spline-based objects using the edit handles, edit toolbar, and specification dialog. See [Editing Spline-Based Objects on page 235](#).

In addition to the standard edit handles for splines, Walkthrough Paths also have an edit handle for each Key Frame. The Key Frame closest to the point where you click displays the Selected Edge Handle Fill color, while the other Key Frame handles use the Secondary Handle Fill color. Both are set in the Preferences dialog. See [Colors Panel on page 98](#).

To reverse the direction of the entire walkthrough, select it and click the **Reverse Direction**  edit button. See [Reverse Direction on page 262](#).

## **KEY FRAMES**





 Key Frames are points along a Walkthrough Path that allow you to change:

- Camera direction, tilt angle, and height;
- Changes in walkthrough speed;
- The floor that the walkthrough is on.

These changes are applied as the camera moves along the Walkthrough Path from one Key Frame to another.



### ***To add a Key Frame to a Walkthrough Path***

1. Select the path and click the **Add Key Frame**  edit button.
2. If you wish to add multiple Key Frames, click the **Sticky Mode**  edit button. See *Sticky Mode on page 170*.
3. Click on the selected path to add a Key Frame at that location. The new Key Frame receives height and angle attributes based on its position on the path and the attributes of the Key Frames before and after it.
4. If you clicked the **Sticky Mode**  button, continue clicking to create additional Key Frames. When you are finished, click the **Main Edit Mode**  edit button or select a different drawing tool.

In plan view, each Key Frame is represented by a camera symbol centered along the walkthrough path. It displays its Key Frame number, is pointed in the direction of its **Camera Angle**, and its position along the path corresponds to its **Time** setting.

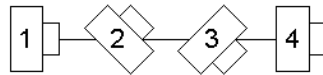

Key Frame **Time**, **Angle**, and other properties can be edited in the Walkthrough Path Specification dialog. See *General Panel on page 1210*.



You can also select a Walkthrough Path and move and rotate each Key Frame using its edit handles.

To remove a Key Frame from a Walkthrough Path, click on its symbol to select it and click the **Delete Key Frame**  edit button. The selected Key Frame can be identified by the color of its Move edit handle. This edit tool can be used to delete the Start and End Key Frames; however, if only two Key Frames are present it will not be available. Key Frames can also be deleted in the Walkthrough Path Specification dialog. See *Selected Edge on page 212* and *General Panel on page 1210*.

## **WALKTHROUGH PATHS AND STAIRS**

If you draw a Walkthrough Path up or down a staircase or ramp, it will follow the height of the stairs or ramp and continue on the next floor.

### ***To create a multiple floor walkthrough***

1. Draw a Walkthrough Path so that it extends into a staircase or ramp in the same direction as its Direction Arrow. See *Displaying Stairs, Ramps, and Landings on page 749*.
  - Do not drag the Walkthrough Path across the entire length of the stairs or ramp. If you do, its height will remain relative to the current floor.
2. When you release the mouse button, the program will automatically display a dashed line with an arrow extending past the last Key Frame on the current floor.
  - If it follows stairs or a ramp going upward, the path will also extend to the top end of the staircase or ramp.
3. Go up or down one floor, select the Walkthrough Path, and resize and reshape it as needed. You can use the **Create Walkthrough Path**  tool to draw more segments and use the **Add Key Frame**  edit tool, as well.

## **PREVIEWING A WALKTHROUGH**



Depending on the quality settings and length of a Walkthrough Path, it may take a considerable amount of time to record a walkthrough video. The Walkthrough Preview side window allows you to preview part or all of an existing walkthrough path to confirm that it meets your needs prior to actually recording it. Select **View > Walkthrough Preview** to

open or close this side window. See [Walkthrough Previews on page 1212](#).

## PLAYING A WALKTHROUGH

Once a walkthrough has been recorded, it can be played using a media player on your system.

### To play a walkthrough

1. Select **3D> Walkthroughs> Play Walkthrough**  to open the Select Video File dialog.
2. Browse to the **.mp4**, **.wmv**, or **.avi** file on saved on your computer. Your system's default video player plays the walkthrough video.

---

## Walkthrough Path Specification Dialog

 Select a Walkthrough Path and click the **Open Object** edit button to open the Walkthrough Path Specification dialog. See [Walkthrough Paths on page 1207](#).

You can also access this dialog by clicking the **Define** button in the Walkthrough Preview side window. See [Walkthrough Previews on page 1212](#).

Most of the settings in this dialog are also found in the Walkthrough Path Defaults dialog.

The Walkthrough Path Specification dialog has the following panels:

## GENERAL PANEL

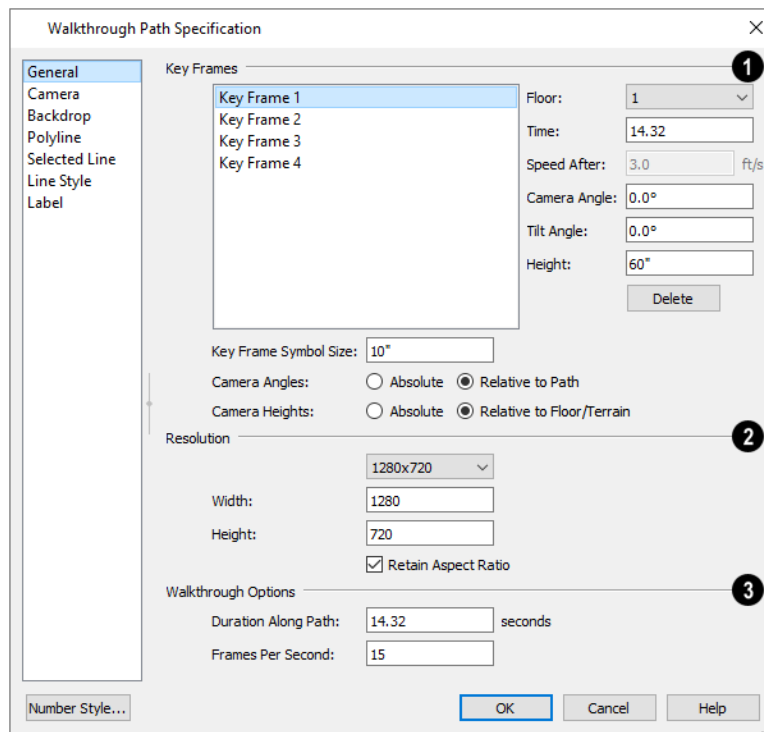

## 1 Key Frames

A list of the selected path's Key Frames displays on the left. Click on a Frame in the list to select and edit it using the settings on the right. When the dialog is opened, the Key Frame selected in plan view will be selected in the list automatically. Most of these settings are also found in the Walkthrough Preview dialog. See [Key Frames on page 1208](#) and [Walkthrough Previews on page 1212](#).

- Specify the **Floor** that the selected Key Frame is located on. See [Multiple Floors on page 730](#).
- Specify the **Time** in seconds at which the selected Key Frame is found in the duration of the walkthrough. The Times of the walkthrough path's first and final frames cannot be moved.
- Specify the **Speed After (ft/s)**, which is how fast the camera moves along the walkthrough path from the current Key Frame to the next. Not available if the last Key Frame is selected.
- Specify the **Camera Angle** at the selected Key Frame.
- Specify the **Tilt Angle** of the camera at the selected Key Frame.
- Specify the **Height** of the camera at the selected Key Frame.
- Click the **Delete** button to remove the selected Key Frame from the path. Key Frames can also be deleted in plan view using the **Delete Key Frame**  edit tool. This option can be used to delete the Start and End Key Frames; however, if only two Key Frames are present it will not be available.
- Specify the **Key Frame Symbol Size**, which is the size of the symbols representing the selected walkthrough path's Key Frames in plan view. See [Key Frames on page 1208](#).

Specify how the **Camera Angles** associated with each key frame are measured:

- Select **Absolute** to measure the Camera Angles relative to the plan's X and Y axes.
- Select **Relative to Path** to measure the Camera Angles frame relative to the direction of the path at that location.

Note: When Relative Angles are used, a Camera Angle of 0° points in the direction of the Walkthrough Path. When Absolute Angles are used, 0° always points in the positive direction along the X axis.

Specify how the **Camera Heights** associated with each key frame are measured:

- Select **Absolute** to measure camera height relative to the plan's Z axis.
- Select **Relative to Floor/Terrain** to measure camera height relative to the floor or terrain at each Key Frame location.

## 2 Resolution

Control the size of the selected walkthrough's frames.

- Select a size from the drop-down list. If the Width or Height is modified below, the selected Resolution will be "Custom".
- The current **Width**, based on the selected Resolution, is stated here. If you change this value, the selected Resolution will be "Custom".
- The current **Height**, based on the selected Resolution, is stated here. If you change this value, the selected Resolution will be "Custom".

### 3 Walkthrough Options

- Specify the **Duration**, or total length of the walkthrough video in seconds.
- Specify the desired number of **Frames per Second**, between 1 and 100. A higher number results in a higher quality recording but also a larger file size.
- In the Walkthrough Path Defaults dialog only, specify the **Video Codec** to use when recording walkthroughs. See [Selecting a Codec on page 1219](#).

#### CAMERA PANEL

The settings on the CAMERA panel let you specify lighting, a Rendering Technique, and more. These settings are also found in the Camera Specification dialog. See [Camera Panel on page 1117](#).

#### BACKDROP PANEL

The settings on the BACKDROP panel are also found in the Camera Specification dialog. See [Backdrop Panel on page 1122](#).

#### POLYLINE PANEL

The POLYLINE panel states the length of the path's **Perimeter**. The **Area** and **Volume** of a walkthrough path will always be described as "Not closed". See [Polyline Panel on page 317](#).

#### SELECTED LINE/ARC PANEL

The SELECTED LINE panel is available when the selected path is a spline or the selected edge is a line as opposed to an arc. See [Line Panel on page 304](#).

The SELECTED ARC panel is available when the selected path edge is an arc as opposed to a spline or line. See [Arc Panel on page 312](#).

See, too, [Selected Edge on page 212](#) and [Change Line/Arc on page 256](#).

#### LINE STYLE PANEL

This panel is similar to the LINE STYLE panel in the Line Specification dialog. See [Line Style Panel on page 305](#).

#### LABEL PANEL

Walkthrough Path labels display in plan view when the "Polylines, Labels" layer is turned on and use the Text Style assigned to that layer.

For more information, see [Label Panel on page 700](#).

---

## Walkthrough Previews



Depending on the quality settings and length of a Walkthrough Path, it may take a considerable amount of time to record a walkthrough video. The Walkthrough Preview side window allows you to preview part or all of an existing walkthrough path to confirm that it meets your needs prior to actually recording it. Select **View> Walkthrough Preview** to open or close this side window. See [Side Windows on page 17](#).

You can also open or close this side window by selecting a Walkthrough Path and clicking the **Walkthrough Preview**  edit button.

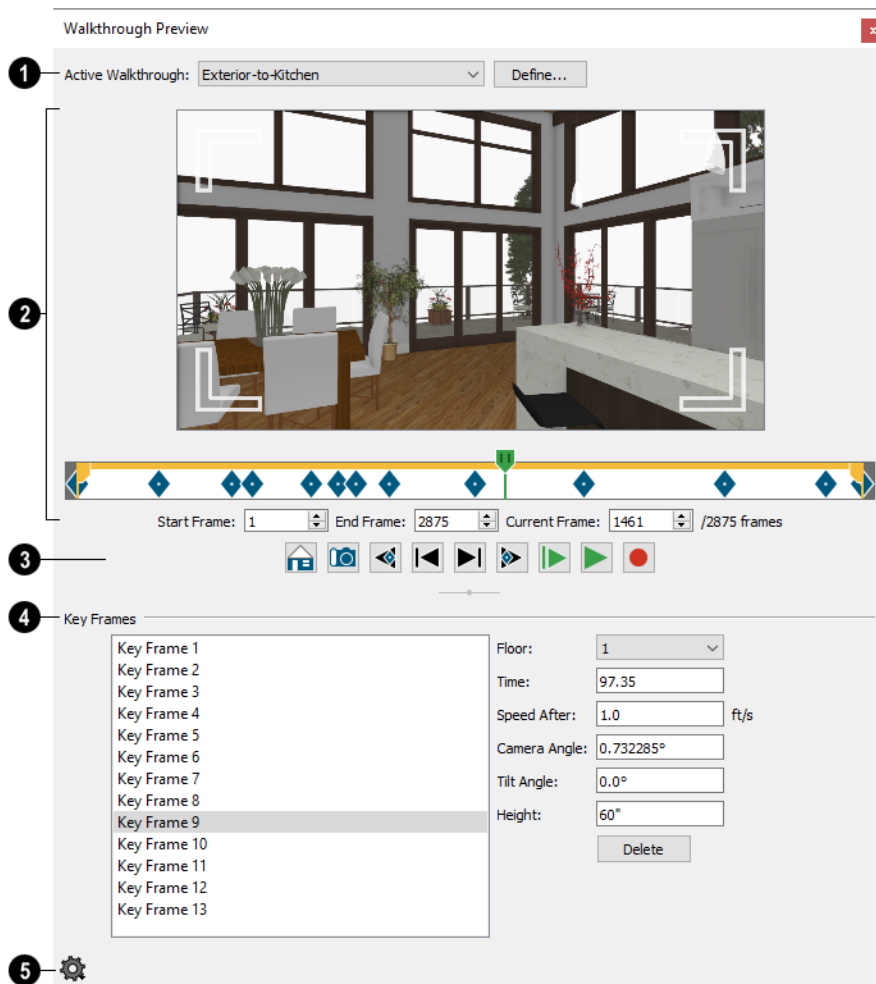

## 1 Active Walkthrough

Select the walkthrough path that you would like to see in the preview from the drop-down list. All walkthrough paths present in the current plan are listed, and are described using their Label.

- Click the **Define** button to open the selected path's Walkthrough Path Specification dialog. See *Walkthrough Path Specification Dialog on page 1210*.

## 2 Preview

A preview of the selected walkthrough displays here. When a preview is not playing, the Current Frame displays.

- Click and drag in the preview window to adjust the Camera Angle and Tilt Angle of the Current Frame.
- Click and drag the green slider bar to control which frame of the walkthrough displays in the preview pane. You can also click anywhere along the slider to move the bar to that location or use the Current Frame setting, below.
- The yellow bar at the top of the slider indicates the duration of the walkthrough and the location of the Start and End Frames selected below. Click and drag the handles at each end to move the Start and End Frames.

- Blue diamonds along the slider show the location of the selected walkthrough's Key Frames, defined below.
- Specify the **Start Frame** of the walkthrough video. This will be the first frame of the walkthrough video when it is recorded using **Custom Frames to Record**, and is Frame 1 by default. See *Record Walkthrough Along Path on page 1215*.
- Specify the **End Frame** of the walkthrough video. This will be the final frame of the walkthrough video when it is recorded using **Custom Frames to Record**, and is the last frame of the walkthrough path by default.
- Specify the **Current Frame**, which displays in the preview pane above and can also be specified using the slider bar. The Current Frame cannot be located before the Start Frame.

### 3 Preview Controls



**Use Recording Quality** shows the preview using the same level of quality as set on the CAMERA panel of the Walkthrough Path Specification dialog. This option is selected by default but may cause slow performance in the preview pane. See *Camera Panel on page 1212*.



**Use Standard Quality** may improve performance if you encounter slowness in the preview pane. This option shows the preview using without shadows, bloom or reflections. In addition, Watercolor and Physically Based Renderings are shown using the Standard Rendering Technique. This setting is retained during the current program session but is reset when the program is relaunched.



**Create Camera View** creates a camera view window using the location and angle of the current frame.



**Jump to Previous Key Frame** moves the preview back one Key Frame. Not available if the Current Frame is located before the Start Frame.



**Go to Previous Frame** moves the preview back one frame. Not available if the Current Frame is located before the Start Frame.



**Go to Next Frame** advances the preview ahead one frame. Not available if the Current Frame is located after the End Frame.



**Jump to Next Key Frame** advances the preview ahead one Key Frame. Not available if the Current Frame is located after the End Frame.



**Play Walkthrough Preview from Beginning** plays a preview of the walkthrough from the Start Frame through the End Frame.



**Play Walkthrough Preview from Current Frame** plays a preview of the walkthrough from the Current Frame through the End Frame.



**Record Walkthrough** records a preview of the walkthrough from the Start Frame through the End Frame.

### 4 Key Frames

Make adjustments to the selected walkthrough path's Key Frames. These settings are also found in the Walkthrough Path Specification dialog. See *General Panel on page 1210*.

- Click on a Key Frame in the list on the left to select and edit it.
- Specify the **Floor** that the selected Key Frame is located on.
- Specify the **Time** in seconds at which the selected Key Frame is found in the duration of the walkthrough. The Times of the walkthrough paths' first and final frames cannot be moved.

- Specify the **Speed After**, which is how fast the camera moves along the walkthrough path from the current Key Frame to the next, in feet per second. Not available if the last Key Frame is selected.
- Specify the **Camera Angle** at the selected Key Frame.
- Specify the **Tilt Angle** of the camera at the selected Key Frame.



The Camera Angle and Tilt Angle can also be adjusted by clicking and dragging in the preview pane, above.

- Specify the **Height** of the camera at the selected Key Frame. You can specify where the Heights are measured from in the Walkthrough Path Specification dialog, which is accessible by clicking the Define button, above.
- Click the **Delete** button to remove the selected Key Frame from the path.

## 5 Walkthrough Preview Control Options

Click the Options  button at the bottom of the side window to specify what settings are presented as well as their layout.

- Select **Preview Pane** to toggle the display of the Preview panel that plays the walkthrough preview or shows the Current Frame
- Select **Key Frame Settings** toggle the display of the Key Frames settings.
- Select **Horizontal Layout** to position the Key Frames settings to the right of the other settings, or select **Vertical Layout** to position the Key Frame settings below the other settings. The side window's shape does not adjust when you switch between layout options, so you may need to resize it by clicking and dragging its edges.

---

## Recording a Walkthrough

There are two approaches to recording a walkthrough of a plan: using a Walkthrough Path, and recording frame by frame, directly from a camera view.

### RECORD WALKTHROUGH ALONG PATH

Once a Walkthrough Path has been drawn, you can use it to record a walkthrough video. See [Creating Walkthrough Paths on page 1207](#).



Depending on the quality settings and length of a Walkthrough Path, it may take a considerable amount of time to record a walkthrough video. You can preview a walkthrough before recording it. See [Walkthrough Previews on page 1212](#).

#### *To record a walkthrough along a path*

1. In plan view, select a Walkthrough Path.
2. Open its specification dialog and make sure the settings on the GENERAL, CAMERA, and BACKDROP panels meet your needs. See [Walkthrough Path Specification Dialog on page 1210](#).
3. On the Camera panel, make sure the Rendering Technique Options meet your needs as well. See [Rendering Technique Options on page 1153](#).

4. Click the **Record Walkthrough Along Path**  edit button.
5. In the Record Walkthrough Options dialog, specify the desired Quality, Resolution, Rendering Options, Video Codec, and the name and save location of your walkthrough file, then click OK.

Note: You can specify your preferred settings, including Key Frame Symbol Size, Compression, and Video Codec in the Walkthrough Path Defaults dialog. See [Default Settings on page 77](#).

6. When you click OK, a camera view will open, showing the progress as the walkthrough is recorded.

To cancel the recording as it is being created, press the ESC key on your keyboard.

## RECORD WALKTHROUGH OPTIONS DIALOG

Most of the settings in this dialog are also found in the Walkthrough Path Defaults dialog.

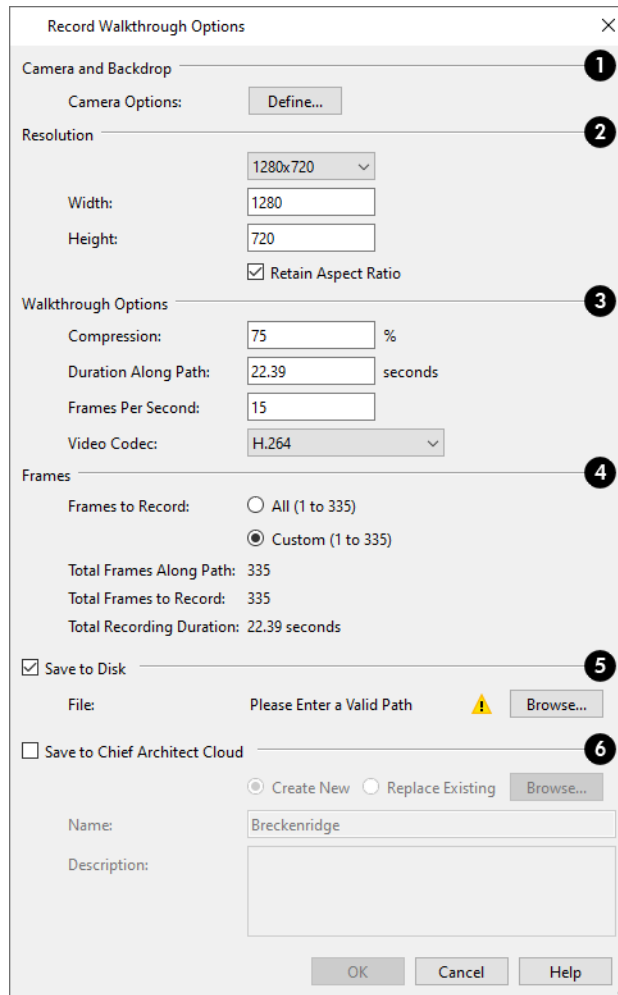

### 1 Camera and Backdrop

Click the **Define** button to open the Record Walkthrough Camera Options dialog, where Rendering Technique, lighting, backdrop, and more for the current walkthrough can be specified. The settings in this dialog are also found in the Camera Specification dialog. See [Camera Specification Dialogs on page 1116](#).



## 2 Resolution

Specify the size of the walkthrough's frames.

- Select a resolution from the drop-down list. If you modify the Width or Height below, "Custom" will become selected.
- The current **Width**, based on the selected Resolution, is stated here. If you change this value, the selected Resolution will become "Custom".
- The current **Height**, based on the selected Resolution, is stated here. If you change this value, the selected Resolution will become "Custom".
- Check **Retain Aspect Ratio** to retain the original ratio between the frame Width and Height. If you modify either value while this is unchecked, the walkthrough may appear distorted.

## 3 Walkthrough Options

- Specify a **Compression** percentage between 0 and 100. A value of 0 gives the highest quality images and largest file sizes.
- Specify a **Duration Along Path**, in seconds.
- Specify the desired number of **Frames Per Second**, between 1 and 100. A higher number results in a higher quality recording but also a larger video file.
- Select a **Video Codec** from the drop-down list. See *Selecting a Codec on page 1219*.

## 4 Frames

This setting is retained between sessions and is also global, affecting all walkthroughs in all plan files.

- Specify the **Frames to Record** by choosing either **All** or a **Custom** range, which is set in the Walkthrough Preview side window. See *Walkthrough Previews on page 1212*.
- The **Total Frames Along Path**, **Total Frames to Record**, and **Total Recording Duration** display for reference.

## 5 Save to Disk

- Check **Save to Disk** to save the walkthrough file to the local hard drive. When this is unchecked, a local copy of the file is not created. See *Saving, Exporting, and Backing Up Files on page 39*.
- Click the **Browse** button to specify a name, save location, and file format for the walkthrough file in the Save Video As dialog. The available file formats may vary, depending on which codec you selected.

## 6 Save to Chief Architect Cloud

- Check **Save to Chief Architect Cloud** to save the walkthrough file to your Chief Architect Cloud Account. Up to 10 uploaded walkthrough files can be stored in our online account at a time.
- Select **Create New** to upload a new walkthrough file or select **Replace Existing** to replace a walkthrough file already in your Cloud Account with a new one.
- Type a short, descriptive **Name** for the walkthrough file.
- Type a brief **Description** of the walkthrough.

When you click OK, the program will begin recording the walkthrough video. If you selected Save to Chief Architect Cloud, you may first be prompted to log in to your Chief Architect Cloud Account. See [Chief Architect Account Login on page 1223](#).

## FRAME BY FRAME WALKTHROUGHS



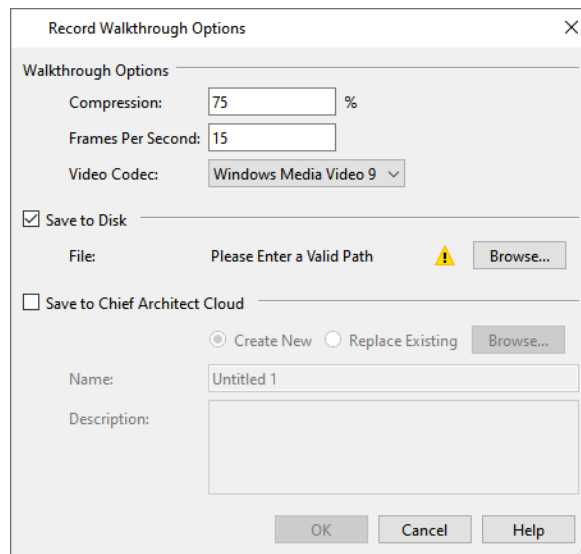

You can also create a walkthrough by recording it frame by frame. Although time-consuming and lacking many of the options that a Walkthrough Path provides, creating a walkthrough in this manner lets you see exactly what is being recorded as you record it.

### *To record a walkthrough frame by frame*

1. Create a camera view. This view is the first frame of the walkthrough.
2. While the camera view is active, select **3D> Walkthroughs> Record Walkthrough** .
3. In the Walkthrough Options dialog:



- Select a **Frame Rate** between 1 and 100. The value entered is the number of frames per second.
- Select a **Compression Percent** between 0 and 100. A value of 0 gives the highest quality images and the largest file size.
- Select a **Codec** from the drop-down list. See [Selecting a Codec on page 1219](#), below.
- Check **Save to Disk**, then click the **Browse** button to specify a name and save location for the walkthrough file. See [Exporting Files on page 41](#).
- Check **Save to Chief Architect Cloud** to save the walkthrough file to your Chief Architect Cloud Account. See [Chief Architect Account Login on page 1223](#).
- Select **Create New** to upload a new walkthrough file or select **Replace Existing** to replace an existing walkthrough file in your Cloud Account with a new one.
- Type a short, descriptive **Name** and a brief **Description** for the file.
- Click OK.

4. Use the camera movement tools to navigate the view. Each time the screen redraws, it is recorded as the next frame in sequence. See *Editing 3D Views on page 1105*.
5. To move the camera without saving a view, select **3D> Walkthroughs> Pause Recording**  to temporarily stop recording.
  - You can then select **3D> Walkthroughs> Save Frame**  button to control what views are saved.
  - You can start recording again by selecting **Pause Recording**  once more.
6. When the walkthrough sequence is complete, select **3D> Walkthroughs> Stop Recording**  or close the view.

Note: Zooming in and out and using the scrollbars does not change the viewpoint and does not produce a frame for the walkthrough.

If you resize the current view window while recording a walkthrough, the program will stop recording.

## SELECTING A CODEC

A codec is a utility that compresses and decompresses media files, and is used when both recording and viewing videos such as walkthroughs. When you record a walkthrough in Chief Architect, you can choose which of the codecs installed on your system you want to use. This selection is universal and is retained between program sessions: when you choose a codec in the Walkthrough Path Defaults or either Walkthrough Options dialog, it will become selected the next time you open either dialog, even if you do so in another plan.

“Windows Media Video 9” is the default codec in the Windows version and “H.264”, in the Mac version; but any codecs installed on your system will be available to use.

To choose the codec that best suits your needs, it is a good idea to create a test walkthrough using each of the codecs installed on your system to see how well their walkthrough quality and file compression meet your requirements. Note that your choice of codec may affect the file formats in the Save Video As dialog.

For more information about codecs, visit [chiefarchitect.com](http://chiefarchitect.com).

---

## Creating VRML Files

 VRML (Virtual Reality Modeling Language) is a 3D file format that can be used by various “walkthrough” viewers, as well as other rendering packages.

VRML files use the **.wrl** file format and contain an entire 3D model, including lighting information. Images and textures can also be referenced. You can post a **.wrl** file and its associated image and texture files to the web or e-mail them to a customer.

VRML files are often created from rendered views so that lighting and textures are used; however, you can export from a Vector View if you wish. See *Editing 3D Views on page 1105*.

The entire model is exported, but the starting point for the walkthrough is defined by the camera location at the time of export.

When a camera view or overview is active, select **File> Export> Export VRML** . The VRML Export Options dialog opens.

## VRML EXPORT OPTIONS DIALOG

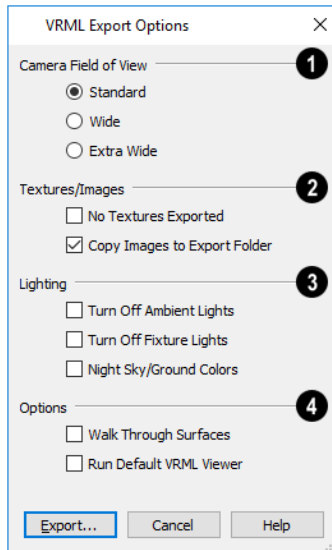

### 1 Camera Field of View

Define the **Camera Field of View**. **Standard** most closely corresponds to the default Chief Architect camera view. The other options generate a wider field of view.

### 2 Textures/Images

Specify how **Textures/Images** are exported.

- Check **No Textures Exported** to prevent texture files from being exported with the **.wrl** file. If textures are exported, the texture files must be in the same folder as the **.wrl** file.
- Check **Copy Images to Export Folder** if you plan to share the VRML with others. This copies texture bitmaps with the **.wrl** file so that they render correctly when exported.

### 3 Lighting

Specify how **Lighting** is exported.

- **Turn off Ambient Lights** turns off the default lights that are used to light a scene.
- **Turn off Fixture Lights** turns off the default lights that are generated for fixtures and used to light a scene.
- **Night Sky/Ground Colors** darkens the ground plane and sky to create a nighttime appearance.

### 4 Options

- **Walk Through Surfaces** allows you to walk through walls and closed doors from room to room, instead of stopping when you reach a wall.
- **Run Default VRML Viewer** starts the **.wrl** viewer and opens the new **.wrl** file as soon as it is generated.

Once the general parameters have been selected, click **OK**. Name the **.wrl** file and save it in the desired folder and click **Save**.



It is best to keep all **.vrm** files in a folder separate from your normal Chief Architect files, since all textures used in the model also export to the same folder. This could add a significant number of files, creating potential organization problems.

## VRML USE OF TEXTURE AND IMAGE FILES

In order for textures to be rendered correctly, the texture and image files associated with an exported VRML file must be in the same directory as the **.wrl** file.

VRML files do not support the use of **.bmp** textures or images. Instead, compressed file formats such as **.gif**, **.png**, or **.jpg** files must be used.

If you wish to use custom textures or images in your VRML file, you have two options:

- Make sure that they are saved in a format other than **.bmp** before you bring import them into Chief Architect. This is the recommended option.
- Create a **.gif** file with the same name and in the same directory as the **.bmp** file. When you export the **.wrl** file, Chief Architect automatically substitutes the **.gif** for the **.bmp** file. Whenever possible, you should use a supported file format instead of using **.bmp** and **.gif** pairs.

For more information about **.vrm** players, visit [chiefarchitect.com](http://chiefarchitect.com).

# Importing and Exporting

## Chapter 36

Importing is the process of opening a file that was produced in a different program in Chief Architect. Exporting, on the other hand, is the process of saving information in a Chief Architect file to a format that can be read by another program.

Chief Architect allows you to import and export a variety of information from and to other applications. This chapter focuses on importing and exporting 2D .dwg/.dxf files and a variety of 3D file formats. Other importing and exporting options are described in the chapters in which those objects or settings are discussed. See *Pictures, Images, and Walkthroughs on page 1184*.

### TOPICS

<b>Chief Architect Account Login</b> .....	<b>1223</b>
<b>Export Chief Architect 3D Viewer File</b> .....	<b>1223</b>
<b>Import Room Planner File</b> .....	<b>1226</b>
<b>DXF vs DWG File Formats</b> .....	<b>1226</b>
<b>Importing 2D Drawings</b> .....	<b>1226</b>
<b>Import Drawing Assistant</b> .....	<b>1228</b>
<b>Exporting 2D DXF/DWG Files</b> .....	<b>1235</b>
<b>Additional 2D Export Information</b> .....	<b>1237</b>
<b>Export 360 Panorama</b> .....	<b>1238</b>
<b>Export Thermal Envelope Data</b> .....	<b>1240</b>
<b>Export to REScheck</b> .....	<b>1240</b>

---

## Chief Architect Account Login

Your online Chief Architect Account allows you to take advantage of a variety of valuable resources including catalog downloads, license management, and technical support. See [Creating a Chief Architect Account](#).

There are a number of tasks in the software that require you to be logged into your Chief Architect cloud account:

- Downloading library catalogs. See [Downloading Library Content on page 963](#).
- Uploading Chief Architect 3D Viewer models. See [Export Chief Architect 3D Viewer File on page 1223](#).
- Uploading 360 Panorama images. See [Export 360 Panorama on page 1238](#).
- Uploading Walkthrough videos. See [Recording a Walkthrough on page 1215](#).
- Importing a drawing from the Room Planner mobile app. See [Import Room Planner File on page 1226](#).

If you try to do this while you are logged out of your cloud account, the Chief Architect Account Login dialog will open, giving you an opportunity to log in.

You can also log into or out of your online account at any time by selecting **Help> Log in to Chief Architect Account** or **Help> Log out of Chief Architect Account**.

### CHIEF ARCHITECT ACCOUNT LOGIN DIALOG

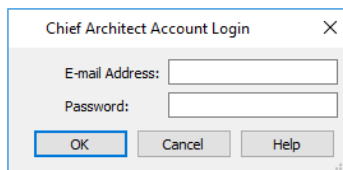

In order to import Room Planner files, you should enter the same **E-mail Address** and **Password** that you used to save the drawing to the cloud in Room Planner.

---

## Export Chief Architect 3D Viewer File



The **Chief Architect 3D Viewer** allows a model created in Chief Architect to be viewed in either:

- A web browser on a computer.
- The 3D Viewer app on a mobile device.

In order to export a Chief Architect 3D Viewer file, you must be logged in to your Chief Architect cloud account.

For more information about the Chief Architect 3D Viewer, visit [chiefarchitect.com](http://chiefarchitect.com).

To export a file to the cloud for viewing with either option, select **File> Export> Export Chief Architect 3D Viewer File**  while a 3D view is active. Up to 99 3D Viewer models can be stored in your online account at a time.

With the exception of Rope Lights, any light sources that are On in the current view, as well as ambient light, will be exported along with the model. See [Lighting on page 1135](#).

Note: Any 3D models referenced using the Reference Display in the current plan cannot be exported to the 3D Viewer. Only the model saved in the current plan file is included in the export. See [The Reference Display on page 738](#).

### 3D VIEWER EXPORT OPTIONS

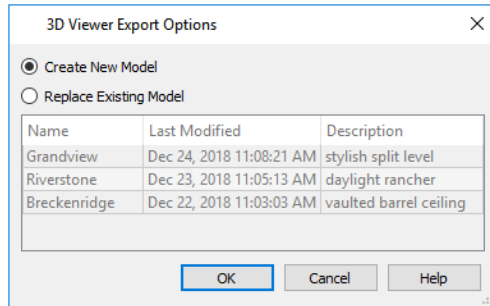

- Select **Create New Model** to export a new model without affecting any previously exported files.
- Select **Replace Existing Model** to select a previously-exported model in the list and replace it with the model being exported now.
- To select an existing model to replace, click on its line item in the table.

The columns in the table are sortable: click a column header to sort all line items in the table by that column. An arrow above the column indicates that it is being used to sort the table, and in which direction it is being sorted.

When you click OK, the Export 3D Viewer File dialog opens, where you can specify the exported model’s name, description, and other details.

### EXPORT 3D VIEWER FILE DIALOG

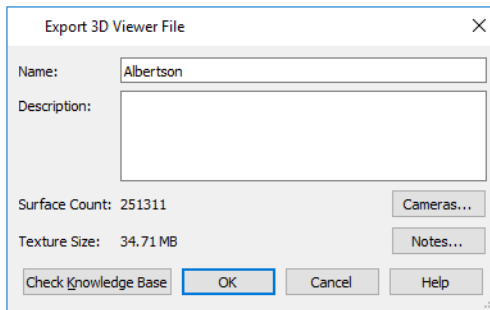

- The **Name** of the current plan file populates this field by default. Specify a different name for the exported 3D Viewer file if you would like.
- Type a brief **Description** of the model.
- Click the **Cameras** button to open the Select Cameras to Export dialog and specify which saved cameras to export with the model. See [3D Views on page 1079](#).
- Click the **Notes** button to open the Select Notes to Export dialog and specify which saved cameras to export with the model. See [Select Notes to Export Dialog on page 1225](#), below.
- The **Surface Count** and **Texture Size** display here for reference. Large Surface Count and/or Texture Size values can impact performance in the app.



 To reduce Surface Count and Texture Size, consider turning off unnecessary layers in the current 3D view before exporting. See [Layers on page 176](#).

When you click OK, the 3D model is exported using the layer settings in the camera view that was active when the model was exported.

On the 3D Viewer page, you can also choose to share an exported model with someone so that it can be opened in a 3D Viewer page or in the 3D Viewer mobile app.

### SELECT CAMERAS TO EXPORT DIALOG

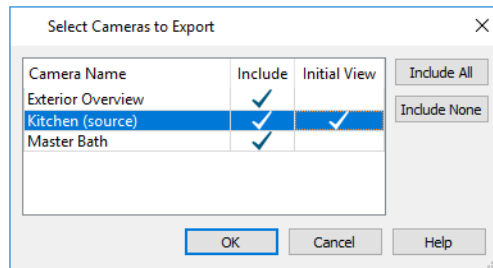

- The **Camera Name** of each saved Perspective Camera and Overview in the plan is listed in a table. The camera that is active when you export the model, if listed, is followed by “(source)”. Floor Overviews can be exported; however, they behave like Full Overviews in the 3D Viewer.
- In the **Include** column, click to add or remove a check mark for each camera that you would like to export. By default, only cameras of the same type, on the same floor, and using the same layer set are Included.
- In the **Initial View** column, add a check mark for the camera that you would like to be active when the model is opened in 3D Viewer.
- Click the **Include All** button to export all saved cameras with the model. A large number of saved cameras may slow down the interface of the 3D Viewer app.
- Click the **Include None** button to export no saved cameras with the model. When the model is opened, an unsaved 3D Overview will be the initial view.

The columns in the table are sortable: click a column header to sort all line items in the table by that column. An arrow above the column indicates that it is being used to sort the table, and in which direction it is being sorted.

### SELECT NOTES TO EXPORT DIALOG

Notes placed in plan and camera views in Chief Architect can be exported with a 3D Viewer model. See [Notes](#), [Note Types](#), and [Note Schedules on page 533](#).

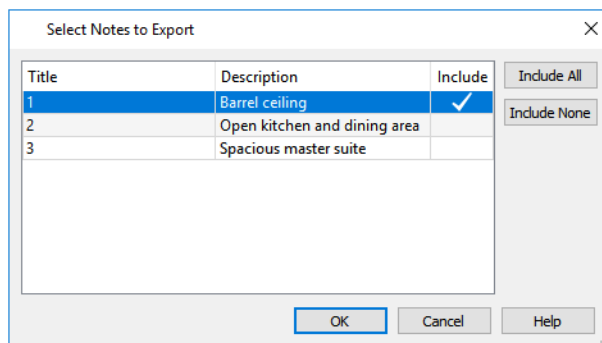

- Each Note's **Title** is listed in the first column. This information corresponds to the Text Above and Below Line in the Note Specification dialog. In the 3D Viewer, this information is used as the note's Title. See [Note/Callout Panel on page 536](#).
- The **Description** of each note is listed in the second column. This information corresponds to the Schedule Text in the Note Specification dialog. In the 3D Viewer, this information is used as the note's Description.
- Click in the **Include** column to add or remove a check mark for each Note that you would like to export.
- Click the **Include All** button to export all Notes with the model.
- Click the **Include None** button to export no Notes with the model.

The columns in the table are sortable: click a column header to sort all line items in the table by that column. An arrow above the column indicates that it is being used to sort the table, and in which direction it is being sorted.

---

## Import Room Planner File



Select **File> Import> Import Room Planner File**, then select and download a Room Planner file from the cloud. See [Chief Architect Account Login on page 1223](#).

Files created in Room Planner version 2 and newer can be imported into Chief Architect X15.

Note that the exterior walls in an imported Room Planner drawing will inherit their thickness and other properties from the Exterior Wall Defaults dialog in the current plan, while interior walls will retain the thickness that was set in Room Planner. See [Exterior and Interior Wall Defaults Dialogs on page 345](#).

Unless a custom ceiling height has been specified in Room Planner, rooms in an imported file use the Default ceiling height set in the Floor Defaults dialog. See [Floor Level Defaults on page 413](#).

By default, window sizes in imported Room Planner drawings are measured from the outside of their frames, just as their Height and Width are in the Window Specification dialog. If you prefer, you can specify that windows are measured from the inside of the frames in the Preferences dialog. See [General Panel on page 102](#).

Visit [roomplanner.chiefarchitect.com](http://roomplanner.chiefarchitect.com) for more information about the Room Planner mobile app.

---

## DXF vs DWG File Formats

**.dwg** is the native AutoCAD® file format. Originally a proprietary format, it is now widely used with many different products.

**.dxf (Drawing eXchange Format)** is a standard file format created by Autodesk for the transfer of data between other programs.

Many design programs can read and write **.dxf** and **.dwg** files. Both formats interpret data as CAD objects such as lines, polylines, and circles. Both formats can also contain 3D data which can be imported into Chief Architect, as well.

Binary **.dxf** format is another related file format. It is easier for computers to read, is more accurate, and occupies less disk space and regular **.dxf** files. When exporting, however, bear in mind that not all applications support binary **.dxf**.

---

## Importing 2D Drawings

2D drawings are imported by reading entities from a **.dxf** or **.dwg** file and creating the equivalent CAD objects in Chief Architect.

Chief Architect X15 can import 2D **.dxf** or **.dwg** files compatible with AutoCAD® through version 2023. See *Import Drawing Assistant on page 1228*.

A **.dxf** or **.dwg** file can be imported into plan view, a CAD Detail, or a cross section/elevation view.

Only drawings created in AutoCAD®'s Model Space can be imported directly into Chief Architect. Entities drawn on the first page of Paper Space are imported as a CAD block and can be inserted into a drawing from the CAD Block Management dialog. See *CAD Block Management on page 333*. Entities drawn on subsequent pages of Paper Space are not recognized.

External references (xrefs) are not recognized by Chief Architect, either.

In general, all Z coordinates are mapped to zero. If an entity in an imported drawing has thickness, Chief Architect ignores it.

## SUPPORTED ENTITIES

The following is a list of the entities that are imported and how they are converted. All other entities are ignored:

- **Lines** - Both 2D and 3D lines.
- **Circles** - Fully supported in 2D.
- **Arcs** - Fully supported in 2D.
- **Ellipses** - Fully supported in 2D.
- **Spline entities** - Fully supported as 2D polylines.
- **Polylines and Lightweight Polylines** - Polylines are imported as polylines. Bumps are converted to arcs. Line widths are ignored.
- **Lightweight Polylines** - Fully supported in 2D.
- **Points** - Points are not supported unless the layer they are on is converted to Elevation Data. See *Importing Elevation Data on page 1276*.
- **Text and Multi-line Text** - Both are imported as Rich Text and mapped to the Text layer. Multi-line text objects retain their original width. The first font in a multi-line text object is applied to the entire object. If that font is unavailable, Arial is used.
- **Multileaders** - Fully supported in 2D.
- **Unicode** - Fully supported in text objects only.
- **Blocks and Block Inserts** - A block is a named group of CAD entities that have been joined together to behave as a single object. A block insert is a reference to such a block. Blocks are loaded by name. If a duplicate name is found, you can specify whether a block is imported under a new name, replaces an existing block or simply uses the existing block of the same name.
- **Hatch entities** - If **Import Hatch entities** is selected on the SELECT FILE page of the Import Drawing Assistant for a **.dwg** file, Hatch patterns are imported as a CAD block consisting of solid black filled polylines.
- **2D Solids** (Not ACIS Solids) - Fully supported in 2D.
- **Solids** - A solid is a 3 or 4-sided filled area. These are imported as 2D faces.
- **3D Faces/Polyface Meshes** - A 3D face has its Z coordinate mapped to zero, and imports as a polyline.
- **Dimensions** - Rotated, aligned and 3-point angular dimensions are supported. All other dimension types are imported as lines and text rather than functioning dimensions.

CAD blocks containing dimensions as text must be exploded before the text can be edited separately. For more on exploding, see *CAD Blocks on page 329*.

- **Attributes** - Attributes are text objects associated with other items, like blocks. These are imported as text objects at the appropriate location but the association with the original object is broken.
- **Line Styles** - Line styles are not imported. Instead, if a style of the same name displays in the Chief Architect line styles, that line style is used. Otherwise, a solid line style is used.
- **Layers**- You can specify which layers in the imported drawing to import into your Chief Architect file. You can also choose how you wish to map drawing layers to layers in the destination file. See [Layers on page 176](#).

## LAYERS

There can be some confusion between importing a layer and mapping a layer; the distinction, however, is important.

You can control which objects in a drawing are imported by choosing to import the layers they are on.

Once you have elected to import a layer, you can then specify how you would like to map it in the Chief Architect drawing. You have three options:

- You can map all layers in the imported drawing to a single Chief Architect layer.
- You can map all layers in the imported drawing to Chief Architect layers of the same name. The program will create those layers if they do not already exist.
- You can use **Advanced Layer Mapping** to individually map each imported layer to a Chief Architect layer.

---

## Import Drawing Assistant



A 2D **.dxf** or **.dwg** file can be imported into any orthographic view: plan view, cross section/elevation views, CAD Details, and layout. For information about supported entities, model and paper space, and other considerations, see [Importing 2D Drawings on page 1226](#).

To import a 2D drawing file, open the view in which you would like to place the drawing and select **File> Import> Import Drawing (DWG/DXF)** to open the welcome page of the Import Drawing Assistant. Click **Next** to continue.

You can also launch the Import Drawing Assistant by dragging a **.dxf/.dwg** file from an operating system window into the Chief Architect window.



CAD Details are an excellent place to import and organize CAD drawings. See [CAD Details on page 337](#).

If the file you are importing is password protected, you will be prompted to enter the password before continuing.

## SELECT FILE

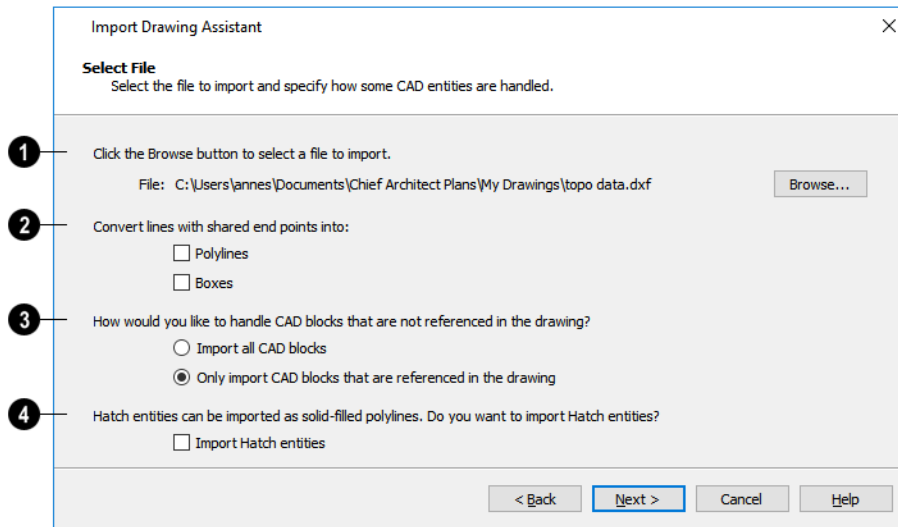

1

Click the **Browse** button to select the file that you wish to import. When a file is selected, its full pathname displays to its left. The directory containing the last file selected using the Import Drawing Assistant displays here otherwise. If the pathname is not a valid dxf/.dwg file, this text will display in red.

Note: If the file you are importing is password protected, you will be prompted to enter the password before continuing.

2

If you want to convert lines with shared end points to polylines and/or boxes, check the appropriate options. Polylines are not affected by these settings, nor are lines that do not share end points.

- Check **Polylines** to import lines with shared end points as polylines.
- Check **Boxes** to import lines with shared end points that form a closed rectangular shape as boxes.

3

Specify how to treat CAD blocks associated with the selected drawing.

- Select **Import all CAD blocks** to include all CAD blocks associated with the file being imported whether or not they are in use. See *CAD Block Management on page 333*.
- Select **Only import CAD blocks if they are referenced in the drawing** to reduce the volume of transferred data.

4

Check **Import Hatch entities** to import areas of hatching as solid-filled polylines.

Click **Next** to load the file into memory so that Chief Architect can present information about the contents of the file. This can take a while for larger files.

## SELECT LAYERS

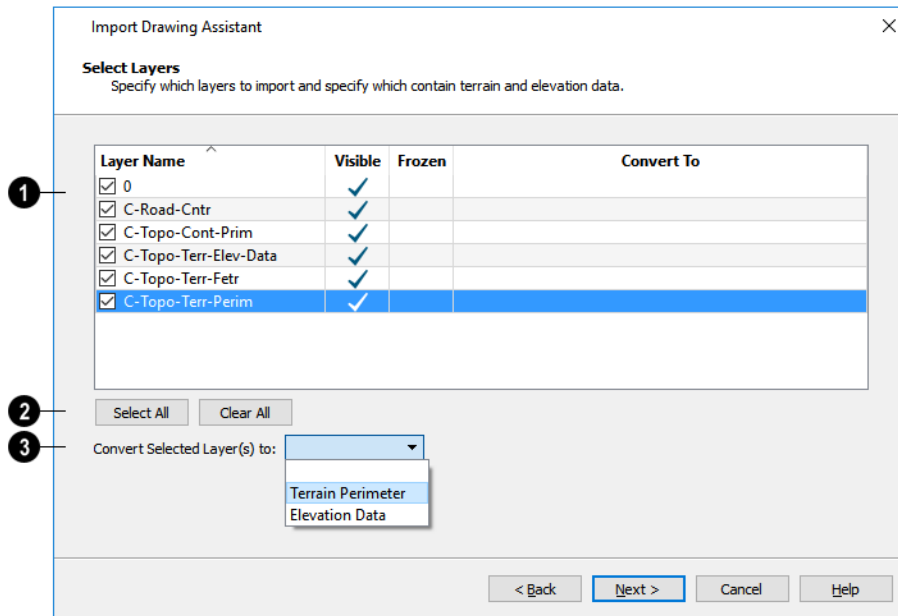

**1**

A list of the layers found in the imported file and information about each layer displays in this table. See [Layers on page 176](#).

- In the **Layer** column, check the box to the left of each layer name to specify which layers you want to import. Layers with checked boxes are imported; those with unchecked boxes are not.
- Layers that were **Visible** in the original program are checked by default. You can include a layer that is not visible by checking the box to the left of its name.
- Layers that were **Frozen** in the original program are not checked by default. You can include a frozen layer by checking the box to its left.
- If a layer is set to **Convert To** a Terrain Perimeter or Elevation Data, it will be indicated in this column provided that you are importing into plan view.

**2**

Click **Select All** to check the box to the left of all layer names in the table. Click **Clear All** to clear the check box to the left of all layer names in the table.

**3**

The **Convert To** drop-down list allows you convert the data on any layer into a Terrain Perimeter or Elevation Data. See [Terrain Perimeter on page 1244](#) and [Importing DWG/DXF Elevation Data on page 1282](#). Only available when importing into plan view.

To convert a layer to a Terrain Perimeter or Terrain Data, click on its name in the table and then select an option from the **Convert To** drop-down list. The option you choose will then display in the **Convert To** column in the table.

Note: If an open polyline is converted into a Terrain Perimeter, the program will draw an additional edge to close the gap.

## LAYER MAPPING

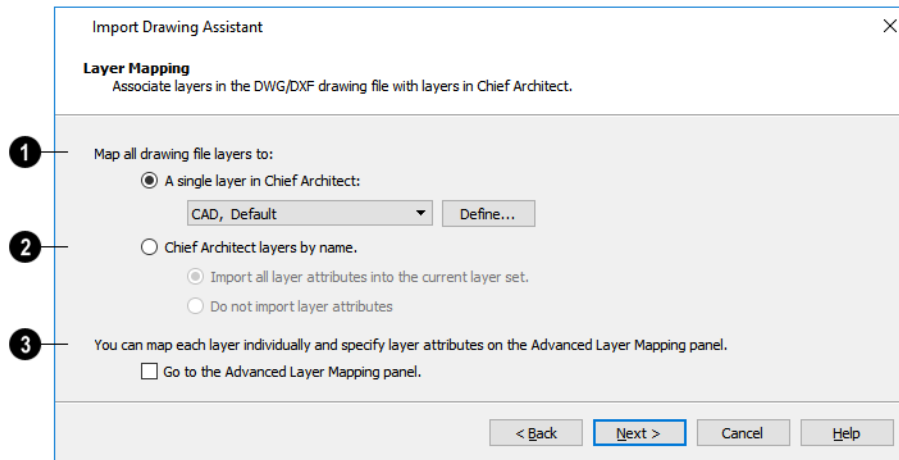

The Layer Mapping page lets you control how layers in the imported drawing are mapped into the destination file.

### 1

The simplest option is select **A single layer in Chief Architect** and assign all objects in the imported drawing to that layer. Original layer attributes are lost, but line color, style, and weight are preserved on a per object basis.

- Select a layer from the drop-down list or click the **Define** button to open the Layer Display Options dialog and specify a layer and its properties. See [Layer Display Options Dialog on page 179](#).

### 2

The second option is to map the layers in the drawing to **Chief Architect layers by name**. Layers are created in the destination file with the same names as those listed on the **Select Layers** window of the Import Drawing Assistant, and the imported CAD objects are placed on those layers.

- In combination with the second alternative, you may choose to import all attributes for each layer into the current Layer Set, or import no attributes at all.

### 3

The third option is to map each layer individually with complete control of all layer mapping options. Selecting the third option opens the Advanced Layer Mapping page.

## ADVANCED LAYER MAPPING

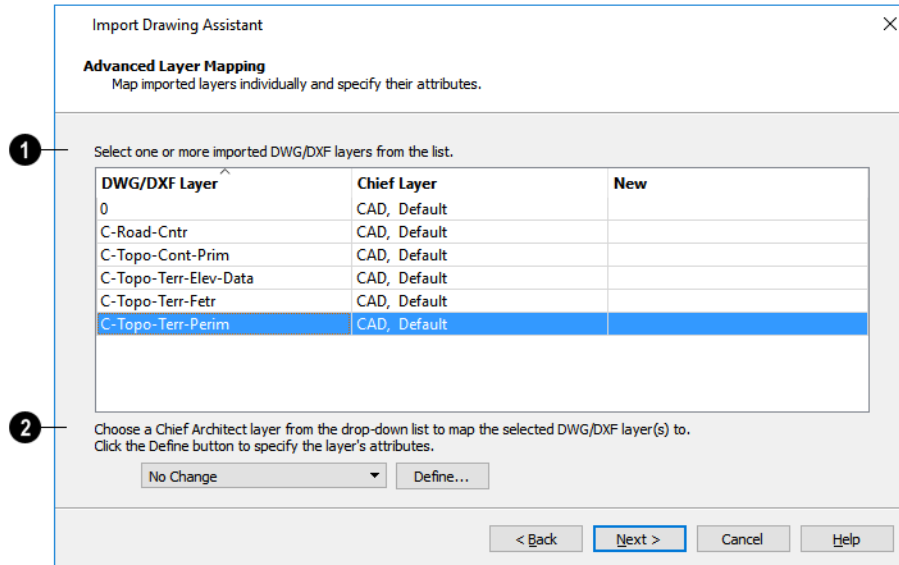

If you select the **Advanced Layer Mapping** option, the Advanced Layer Mapping page displays, allowing you complete control of how all imported layers are mapped.

### 1

A list of the layers found in the imported file and the layers in Chief Architect that they are mapped to display in this table.

- The original name of each **DWG/DXF Layer** is found in the first column.
- The name of the **Chief Layer** that each imported layer is mapped to is listed in the second column. The initial Chief Layer selections depend on which option was selected on the Layer Mapping page. See [Layer Mapping on page 1231](#).
- If a Chief Layer does not already exist in the destination plan or layout file, it will be listed as “**New**” in the third column.

### 2

When a row in the table above is selected, the **Chief Layer** options become active. Select multiple entries by holding down the Shift key.

- If the layer in the selected row is mapped to an existing Chief layer, it will display in the drop-down; if not, the drop-down will be blank.
- Select a layer already present in the destination plan or layout file from the drop-down list.
- Click the **Browse** button to open the Layer Display Options dialog. See [Layer Display Options Dialog on page 179](#).

Click **Next** to continue.

## DUPLICATE CAD BLOCKS

If one or more CAD blocks in the imported file have the same name as a CAD block in the destination plan or layout, the Duplicate CAD Blocks page will display. See [CAD Blocks on page 329](#).



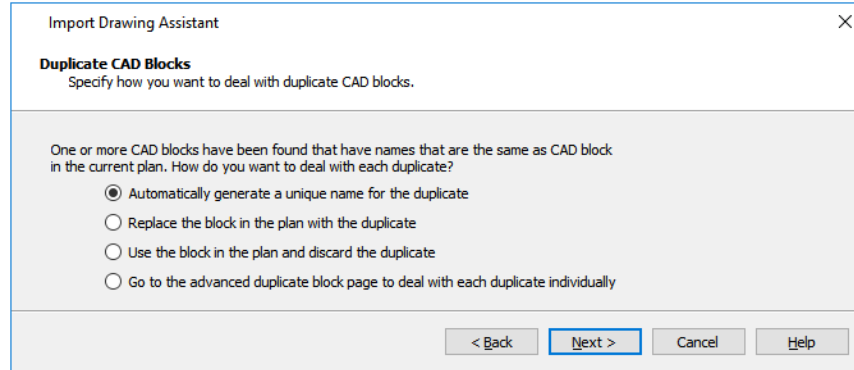

There are four options. The first three apply to all duplicate CAD blocks in the plan.

- The first choice is to have the program automatically generate unique names for each duplicate. For instance, if the original file’s name is “blockname,” the program gives the new block a name like “blockname\_Copy\_1”.
- The second option is to replace the block already in the plan with the duplicate being imported. This option is not recommended, as every instance of the CAD block in the plan will be replaced.
- The third is to keep the block that already exists in the plan and discard the duplicate being imported.
- Select the fourth option to open the Advanced Duplicate CAD Blocks page and manage each duplicate individually.

Click **Next** to continue.

## ADVANCED DUPLICATE CAD BLOCKS

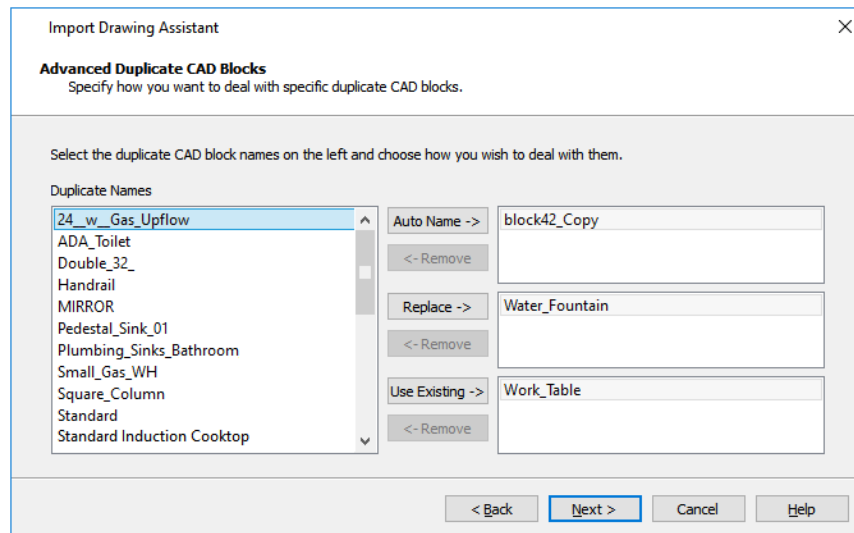

If you chose the fourth option on the Duplicate CAD Block page, the Advanced Duplicate CAD Block page displays, allowing you to manage each duplicate CAD block individually.

Click on a CAD block name in the list of **Duplicate Names**. Select multiple names by holding down the Shift key.

Click one of the three active buttons in the center of the dialog to specify how the selected block(s) are to be treated.

- Click **Auto Name** to have the program automatically generate a unique name for the selected CAD block. The duplicate’s name is the same as the original with “\_Copy” appended to the end.
- Click **Replace** to replace the existing CAD block in the destination file with the CAD block listed here. This option is

not recommended, as all instances of the CAD block are replaced.

- Click **Use Existing** to keep the CAD block already in the destination file and discard the CAD block listed here.

Review your choices in the tables at the right.

- To remove a CAD block from a field on the right, select it and click the **Remove** button.

Click **Next** to continue.

## DRAWING UNIT

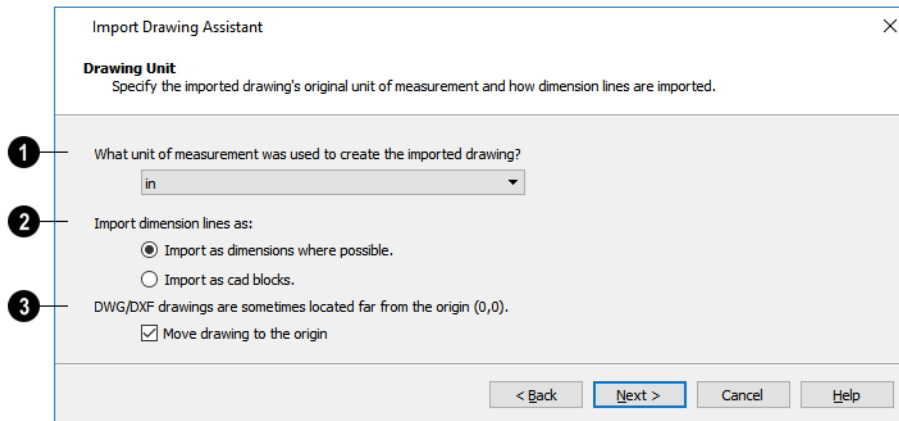

### 1

Select a unit of measurement from the drop-down list. Selecting the correct unit helps ensure that your imported drawing is accurately sized.

Note: During the import process, Chief Architect defaults to inches or millimeters. If you are importing a site plan or topo prepared by a surveyor, or importing a metric drawing into an U.S. Unit plan (or vice versa), you may need to change units.

If the file being imported was drawn at a scale other than 1:1, you can compensate for this scaling by creating a custom unit of measurement and specifying it here. See [Unit Conversions Panel on page 109](#).

### 2

Specify how dimensions are imported.



- Select **Import as dimensions where possible** to import dimensions as Chief Architect-supported dimension lines.
- Select **Import as CAD blocks** to import dimensions as CAD entities that are not recognized by Chief Architect as dimensions.

### 3

Check **Move drawing to the origin** to place the drawing at 0,0. When this is unchecked, it is imported to the same location as it was drawn in the original application. See [3D Drafting on page 13](#).

## IMPORT COMPLETE

When a **.dxf/.dwg** file is imported into Chief Architect, all of its components are selected as a group. The selection set has Move and Rotate edit handles available for relocating the entire drawing, as well as a variety of edit tools. Once another object or tool is selected, the drawing components are no longer group-selected.

If you do not see your imported drawing, select **Window> Fill Window** , as it may have been placed at a location not currently visible on screen. When the drawing can be seen, move your mouse pointer over it and note its coordinates in the Status Bar. If any coordinate value has more than six digits, use the **Transform/Replicate Object**  edit button to move it closer to the origin. See *Transform/Replicate Object Dialog on page 266*.

Imported CAD objects can be selected and edited just like objects that were drawn in the program. See *Editing Objects on page 205*.

 The CAD to Walls tool can be used to convert imported CAD lines in plan view into doors, windows, walls and railings. See *CAD to Walls on page 383*.

---

## Exporting 2D DXF/DWG Files

Line-based 2D files can be exported from Chief Architect in both **.dxf** and **.dwg** file formats. You can specify the version of AutoCAD® to export to. Compatibility with other software may vary.

Custom line styles created in Chief Architect Premier cannot be exported. When exported to **.dxf/dwg**, they are replaced by a solid line style, although the line weight and color are retained. See *Line Styles on page 199*.

There are two ways to export a 2D drawing file in Chief Architect: Export Current View and Export All Floors.

### EXPORT CURRENT VIEW



To export the currently active plan view, CAD Detail, or 3D view, select **File> Export> Current View (DWG/DXF)**.

Bear in mind that Orthographic views are drawn to scale and will produce a 2D drawing that can be accurately dimensioned. Perspective views, on the other hand, are not scaled and do not produce drawings that can be dimensioned accurately. See *Perspective and Orthographic Views on page 1080*.

### EXPORT ALL FLOORS



To export the plan view for all floor plans simultaneously, select **File> Export> All Floors (DWG/DXF)** from any floor of the plan. The floor plans are exported to a single **.dxf** or **.dwg** file.

If you choose to export all floors, the file will contain all floors superimposed on each other. Upon export, each layer in your Chief Architect drawing is divided into separate layers: one for each floor. For example: “Electrical-2” contains objects on Floor 2 that were originally on the “Electrical” layer.

 You can use the CAD Detail from View tool to automatically create a 2D line drawing from a 3D Vector View. See *CAD Detail from View on page 338*.

## EXPORT DRAWING DIALOG

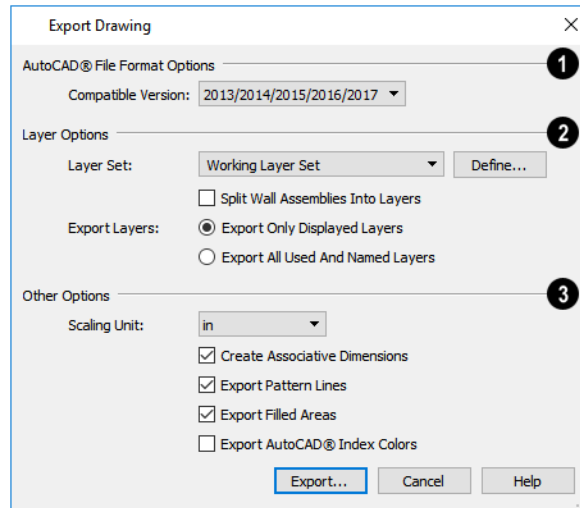

### 1 AutoCAD® File Format Options

.dxf and .dwg files created by Chief Architect can be compatible with a variety of AutoCAD® versions. Specify which version from the drop-down list.

### 2 Layer Options

The **Layer Options** settings allow you to control the layers associated with the file being exported. See *Layers on page 176*.

- Select a **Layer Set** to for the drawing being exported. See *Layer Sets on page 182*. Not available in layout files.
- Click the **Define** to open the Layer Display Options dialog and modify the selected Layer Set. Not available in layout files.



You can create a custom layer set to accommodate desired naming conventions or display attributes.

- **Split Wall Assemblies Into Layers** - The lines that represent wall layers can be exported onto different layers, allowing them to be displayed separately. See *Wall Type Definitions on page 384*.
- Select **Export Only Displayed Layers** to export only those layers that are displayed on screen. This is what always occurs when exporting from layout, but is not an available option in layout files.
- Select **Export all used and named layers** to export all layers that either have something on them or have a layer name specified. Not available in layout files.

### 3 Other Options

- **Scaling Unit** - Select the unit of measurement to be used. For best results, choose inches or feet for U.S. Unit plan or layout files, or metric units for metric files. See *Dimension Preferences and Defaults on page 449*.

- Uncheck **Create Associative Dimensions** to export dimensions as simple CAD entities that are not recognized dimensions by other programs. Associative dimensions are recognized by AutoCAD® and many other CAD programs.

When exporting a layout page, it is often best to uncheck this box.

- Check **Export Pattern Lines** to export pattern lines. Pattern lines are exported as normal CAD lines.
- Check **Export Filled Areas** to export filled areas as AutoCAD® 2D solid entities.
- Check **Export AutoCAD® Index Colors** to automatically map all colors used in the drawing to the closest 256 AutoCAD® Index Color (ACI). Black (RGB 0,0) and white (RGB 255,255,255) are mapped to ACI 7. When unchecked, colors are exported using RGB colors.

Dimension lines using non-default primary or secondary formatting will lose their changes and will use the default format (s) upon export.

When you are satisfied with your selections, click the **Export** button to save the exported file as either a **.dwg**, **.dxf**, or **binary .dxf** file.

Note: Binary .dxf is easier for computers to read, is more accurate, and occupies less disk space, but some applications do not support binary .dxf.

---

## Additional 2D Export Information

The export process converts high level Chief Architect objects (doors, windows, etc) into simple, CAD-based objects (lines, arcs, etc). Chief Architect exports all data to AutoCAD®'s Model Space.

### SUPPORTED ENTITIES

The following entity types are currently supported for 2D export:

- **Line** - The simplest entity. In AutoCAD®, lines are 3 dimensional with the Z coordinate set to zero.
- **Arc** - Arcs have a start angle, end angle and radius.
- **Circle** - Fully Supported.
- **Multi Line Text** - If exporting to an AutoCAD® release that supports multi-line text, Chief Architect writes the file as multi-line text. If exporting to a version that does not support multi-line text, the file is written as simple text.
- **Unicode Text** - Fully supported.
- **Polylines** - Polylines are a collection of points with lines or arcs connecting them. Chief Architect supports both lines and arcs. Arcs are referred to as bulges in AutoCAD®.
- **Block Insert** - A block insert is a reference to a block, which is a named collection of entities. A block can also contain block inserts.

### DIMENSIONS

Aligned, rotated, and angular dimensions can all be exported. CAD blocks containing dimensions as text must be exploded before the text can be edited separately. See [CAD Blocks on page 329](#).

Dimensions with text added using the **Add Additional Text**  tool are not supported when exported to .dxf/.dwg. When exported, they are converted to text and CAD lines. See [Add Additional Text on page 482](#).

Each dimension has an associated block containing a representation of the dimension as it is drawn in Chief Architect. It also contains all the data to recreate that information.

- When an exported dimension is modified in AutoCAD® or other CAD program, its appearance changes.
- Chief Architect does not support arrowhead styles or fonts.
- Three kinds of dimensions are generated: Aligned, Rotated and 3 Point Angular.
- Please refer to AutoCAD® documentation for more information.

Note: Uncheck “Use Associative Dimensions” in the Export Drawing File dialog if the CAD program you are using does not support AutoCAD® Associative dimensions. See [Export Drawing Dialog on page 1236](#).

## LAYERS

Layers in other systems are similar to Chief Architect layers, but there are some subtle differences. Layer information is mapped as follows:

Chief Architect	Other Systems
<b>Name</b>	Name
<b>Color</b>	Nearest AutoCAD® Color. Chief Architect uses the default AutoCAD® color table to determine this mapping.
<b>Display</b>	On
<b>Size</b>	Line Weight. In AutoCAD®, line weights are determined by a table of mm line widths. Chief Architect maps to the closest match in this table based the current view’s Line Weight Scale. See <a href="#">Drawing Sheet Setup Dialog on page 1367</a> .
<b>Style</b>	Line type
<b>Lock</b>	Lock

## LINE TYPES

A line type, or line style, is used by layers and entities to determine how lines are drawn. Chief Architect line types installed with the program are supported on export; custom, user-created line styles, however, are not. See [Line Styles on page 199](#).

# Export 360 Panorama



The **Export 360 Panorama** tool creates a spherical panoramic image that can be opened in various panorama viewers. Select **File> Export> Export 360 Panorama** while a 3D view is active to access this tool.

For best results, position the camera as near as you can to the center of the scene before exporting.

## EXPORT 360 PANORAMA FILE

All of the settings in this dialog are retained during the current program session.

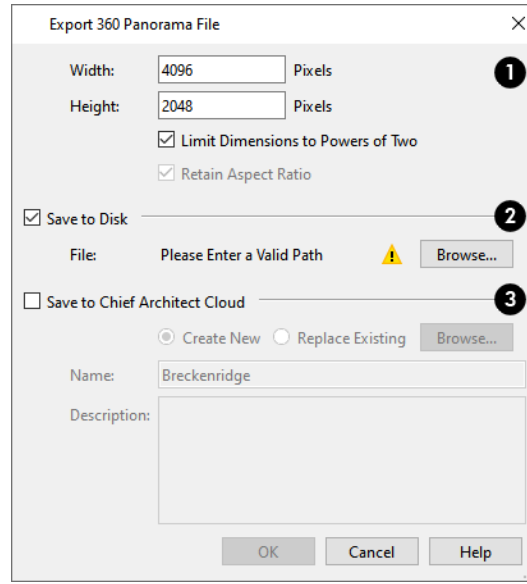

**1**

Specify the size of the exported image, in pixels.

- Specify the **Height** and **Width** of the exported image file, in pixels.
- Check **Limit Dimensions to Powers of Two** to restrict the Width and Height to values that are powers of two. When this is checked and an ineligible value is entered, it will adjust up or down to the nearest power of two. Although not required, this option is recommended for best results in some panoramic image viewers.
- The **Retain Aspect Ratio** check box displays for reference and cannot be changed. The ratio between Width and Height is 2 to 1 when Limit Dimensions to Powers of Two is unchecked, above.

**2 Save to Disk**

Check **Save to Disk** to save the exported panoramic image file on the local computer system.

- Specify the full pathname of the **File** you wish to export, or click the **Browse** button to open the Export 360 Panorama File dialog, which is a typical File Save dialog. See *Exporting Files on page 41*.

**3 Save to Chief Architect Cloud**

Check **Save to Chief Architect Cloud** to save the exported panoramic image file to your Chief Architect Cloud Account. Up to 99 uploaded panoramic images can be stored in your online account at a time. See *Chief Architect Account Login on page 1223*.

- Select **Create New** to upload a new image or select **Replace Existing** to replace a panoramic image already in your Chief Architect Cloud Account with a new one.
- Type a short, descriptive **Name** for the exported panoramic image file.
- Type a brief **Description** of the file.

When you click OK, a panoramic image is created and a progress dialog may display. Because spherical panoramas are composed of multiple images stitched together, they may take longer to create than a standard exported picture.

Note: You can also upload a previously saved panoramic image file to the cloud on the 360 Panoramas page of your online account.

**Generate as 360° Panorama** is also an option in the CPU Ray Trace Options dialog. See *General Panel on page 1171*.

---

## Export Thermal Envelope Data

A thermal envelope is a three dimensional boundary built around a structure's conditioned space that separates it from the unconditioned space around it. Thermal Envelopes are composed of floor platforms, ceiling platforms, walls, doors, and windows. You can export information about the thermal envelope of the current plan by selecting **File> Export> Thermal Envelope Data**. This data is organized by floor level; notes the direction of walls, doors, and windows; and reports the area of each envelope component.

Thermal Envelope Data is exported to a comma delimited **.csv** text file which can be opened in a text editor or spreadsheet application. Once exported, it will automatically open in the application associated with **.csv** files on your system.

Thermal Envelope information is also included when data is exported to REScheck. See *Export to REScheck on page 1240*.

---

## Export to REScheck

 REScheck™ is a residential energy code compliance program offered by the U.S. Department of Energy that evaluates the thermal envelope of a structure and determines how well it meets various energy codes. For more information, visit: [www.energycodes.gov/rescheck](http://www.energycodes.gov/rescheck).

To export a plan's thermal envelope information for use in REScheck™, select **File> Export> Export to REScheck** .

Chief Architect Premier exports using the **.rxl** file format, which can be used by both the desktop and web-based versions of REScheck™.

### EXPORT TO RESCHECK DIALOG

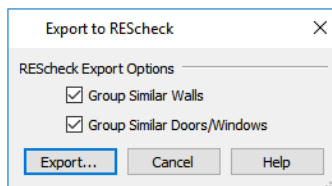

- Uncheck **Group Similar Walls** to treat walls on multiple floors separately. When checked, walls with the same properties and orientation are added together and treated as one wall, regardless of the floors they are on.
- Uncheck **Group Similar Doors/Windows** to treat all doors and windows separately. When checked, doors and windows with the same properties and orientation are added together and treated as one item.

Click the **Export** button to open the Export REScheck File dialog, which is a typical Save File dialog. See *Exporting Files on page 41*.

### EXPORTED PROJECT DATA

Chief Architect Premier can export the following REScheck Project:

- **Front Faces** - The side of the house that faces down on-screen is considered the front, and North is considered up on-screen unless a North Pointer is used. See *North Pointer on page 1143*.
- The **Conditioned Floor Area** is calculated and exported by Chief Architect Premier. See *Exported Envelope Data on page 1241*, below.



- The **Owner/Agent** information is drawn from the plan file's Client Information. See [Designer/Client Information on page 541](#).
- The **Designer Contractor** information is drawn from the plan file's Designer Information.

In a REScheck report exported from Chief Architect Premier, the Project Type is set as "New Construction" and "1-and-2 Family, Detached" is selected under Building Characteristics. Location and Title/Site/Permit are not exportable.

## EXPORTED ENVELOPE DATA

Conditioned Area is the space within a building that is heated and/or air conditioned, and a Thermal Envelope is a three dimensional boundary built around the Conditioned Space that separates it from the unconditioned space around it. Thermal Envelopes are composed of floor platforms, ceiling platforms, walls, doors, and windows.

Rooms that are assigned an interior Room Type are included in the Conditioned Area by default. "Open Below" rooms are also included; however, other hybrid Room Types as well as exterior Room Types are not. See [Room Types and Functions on page 415](#).

You can specify that any room be included in or excluded from the Conditioned Area in the Room Specification dialog. See [General Panel on page 438](#).

Nearly all REScheck Envelope data can be exported from a Chief Architect plan:

- **Floors** - The Assembly type, Gross Area, and Cavity and Continuous R-Values are exported. See [Floor and Ceiling Platform Definitions on page 429](#).
- **Slabs on Grade** - The Slab Perimeter and Continuous R-Value are exported. Slab Depth of Insulation is not included and must be entered manually. See [Foundations on page 705](#).
- **Ceilings** - The Assembly type, Gross Area, and Cavity and Continuous R-Values are exported.
- **Walls** - The Assembly type, Orientation, Gross Area, and Cavity and Continuous R-Values are exported. All are exported as Walls rather than Basement or Crawl Walls. Like walls on the same floor are grouped by orientation. See [Building Orientation on page 1241](#), below, and [Wall Type Definitions Dialog on page 387](#).

Note: The On Center Spacing of Framed walls is derived from the framing material assigned to the wall type's Main Layer. See [Materials and the Materials List on page 1063](#).

- **Doors and Windows** - The Assembly type, Orientation, Gross Area, U-Factor, and Solar Heat Gain Coefficient (SHGC) are exported. Doors are always categorized as doors rather than as windows: even when a door is specified as a Glass Door or when it is part of a mulled unit. See [Energy Values Panel on page 606](#).

If any walls forming the thermal envelope have labels, they will be exported and used in the REScheck report. If similar walls are grouped, their labels will not be used unless the labels are all identical. See [Wall Labels on page 364](#).

Information about skylights is not exported.

## BUILDING ORIENTATION

Walls, doors, and windows are categorized as north-, south-, east-, or west-facing for the purposes of conditioned area totals. These directions are based on the orientation of the plan's **North Pointer** . If no North Pointer is used, north is assumed to be straight up on screen in plan view. See [North Pointer on page 1143](#).

- If a wall is oriented at 45° or less to north in a plan, it will be categorized as a "North" wall. Any doors and windows in this wall will also be categorized as "North".
- Similarly, walls, doors, and windows oriented within 45° of south, east, or west will be classified as "South", "East" or "West", respectively.

The orientation of a curved wall is based on the direction of its chord. See *Drawing Arcs - Arc Creation Modes on page 307*.

# Terrain

## Chapter 37

Chief Architect Premier allows you to model the terrain around a house. Begin by specifying elevation data that creates the surface contours, and then add surface features such as planting areas and water features in level terrain around your house plan.

You can import terrain data from a variety of sources and use this data to produce your 3D model.

Once the terrain is modeled, shadows that follow the terrain can be created using the Sun Angle tool. See [Sun Angles and Shadows on page 1143](#).

Driveways, parking lots, and sidewalks as well as plants and sprinklers are among the objects that can be placed in your terrain and are discussed in [Plants and Sprinklers on page 1293](#) and [Roads, Driveways, and Sidewalks on page 1283](#).

### TOPICS

<b>Terrain Toolbar Configuration</b> .....	<b>1244</b>
<b>Terrain Perimeter</b> .....	<b>1244</b>
<b>Elevation Data Tools</b> .....	<b>1246</b>
<b>Terrain Modifier Tools</b> .....	<b>1251</b>
<b>Terrain Features</b> .....	<b>1252</b>
<b>Terrain Wall and Curb Tools</b> .....	<b>1254</b>
<b>Terrain Objects in the Library</b> .....	<b>1256</b>
<b>Displaying Terrain</b> .....	<b>1256</b>
<b>Editing Terrain Objects</b> .....	<b>1257</b>
<b>Terrain Specification Dialog</b> .....	<b>1258</b>
<b>Elevation Point Specification Dialog</b> .....	<b>1263</b>
<b>Elevation Line/Region Specification Dialog</b> .....	<b>1264</b>
<b>Flat Region Specification Dialog</b> .....	<b>1265</b>
<b>Hill / Valley Specification Dialog</b> .....	<b>1266</b>
<b>Raised / Lowered Region Specification Dialog</b> .....	<b>1268</b>
<b>Terrain Feature Specification Dialogs</b> .....	<b>1268</b>
<b>Grass Region Specification Dialog</b> .....	<b>1270</b>
<b>Terrain Break Specification Dialog</b> .....	<b>1272</b>
<b>Terrain Path Specification Dialog</b> .....	<b>1273</b>
<b>Importing Elevation Data</b> .....	<b>1276</b>
<b>Import Terrain Assistant</b> .....	<b>1277</b>
<b>Import GPS Data Assistant</b> .....	<b>1280</b>
<b>Importing DWG/DXF Elevation Data</b> .....	<b>1282</b>
<b>Converting CAD Objects to Terrain Data</b> .....	<b>1282</b>

---

## Terrain Toolbar Configuration



The Terrain and Road Tools can be accessed through the Terrain menu. You can also display these tools on your toolbar using the **Terrain Configuration**. See [Toolbar Configurations on page 130](#).

The Terrain Configuration and Terrain menu both display the following Terrain, Road, Plant, and Sprinkler parent tools:



**Elevation Data Tools** allow you to add elevation data to your terrain.



**Terrain Modifier Tools** model changes in elevation within a defined area.



**Terrain Feature Tools** let you add materials over the top of the terrain.



**Garden Bed Tools** create Terrain Features with a mulch material.



**Water Feature Tools** create Terrain Features with a water material.



**Stepping Stone Tools** are used to create paths composed of multiple Terrain Features.



**Terrain Wall and Curb Tools** let you draw walls and curbs that follow the terrain.



**Road, Driveway and Sidewalk Tools** allow you to create paved areas that can form intersections.



**Plant Tools** allow you to place plant images and 3D plant symbols.



**Sprinkler Tools** are used to lay out sprinkler symbols and irrigation lines.

---

## Terrain Perimeter



The Terrain Perimeter is a closed polyline defining the boundary of the terrain that generates in 3D views and of the contour lines that generate in plan view. Select **Terrain> Create Terrain Perimeter** to create a terrain perimeter.

A CAD polyline can also be converted into a terrain perimeter. See [Editing Terrain Objects on page 1257](#).

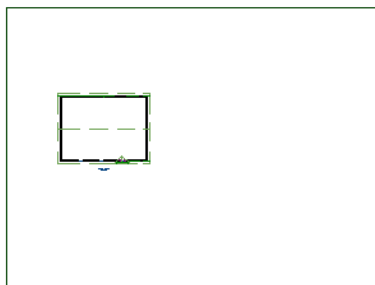



If you create a terrain perimeter in plan view but do not see it, select **Window> Fill Window** . See [Zoom Tools on page 153](#).

When created in a new, blank plan, a new terrain perimeter will be 50' x 100'. If you create a terrain perimeter after you have drawn all or part of a 3D model, it may increase in size as needed to encompass the structure(s) in plan view.

Once created, the terrain perimeter can be resized and edited like other polyline-based objects. See [Editing Closed Polyline-Based Objects on page 228](#).

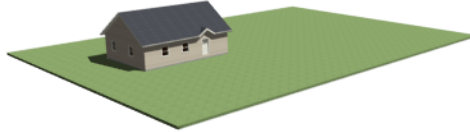
When a terrain perimeter is first created, it is completely flat and is placed at a height of 0'-0", or sea level.



The terrain perimeter by itself does not have elevation data associated with it. You can use the **Elevation Data**  and **Terrain Modifier**  tools to create terrain that slopes in a wide variety of ways. If you do not create elevation data within the terrain perimeter, the terrain remains flat at an elevation of 0' - 0". See [Elevation Data Tools on page 1246](#) and [Terrain Modifier Tools on page 1251](#).

The Terrain Perimeter has a variety of editable properties, including many that affect the appearance of the terrain in 2D and 3D views. See [Terrain Specification Dialog on page 1258](#).

## PLOT PLANS AND PLAN FOOTPRINTS

Using the CAD drawing and editing tools, you can create an accurate plot plan of any building site.

Another approach is to use the **Plan Footprint**  tool and other CAD Tools in a CAD Detail. See [Plan Footprint on page 339](#).

## TERRAIN HEIGHT VS FLOOR HEIGHT

Chief Architect always defines the default height of Floor 1 at 0'-0". This height value is the constant by which the heights of structural elements in the program like walls, floors, and ceilings are measured. The heights of architectural object can be measured relative this absolute height, as well. See [Floor 1 Default Height on page 414](#).

The default height of Floor 1 is not, however, the absolute by which terrain elevation is measured. Instead, elevation data is measured relative to sea level. This means that if you want to, you can use real-world elevation data to generate a 3D terrain model without also having to measure floor and ceiling heights from sea level. See [Importing Elevation Data on page 1276](#).

The program automatically positions Floor 1 a set distance above the terrain. To do this, it first calculates the average elevation of the building footprint's perimeter and then assigns that average elevation to the center point of the building footprint. Finally, it adds the thickness of the floor platform to this value. If a foundation is present, it also adds the thickness of any sill plates plus either 6" (150 mm) or 8" (200 mm) depending on the foundation type. The resulting value, referred to as the automatic Subfloor Height Above Terrain, is how far the default height of Floor 1 is above sea level in the current plan. See [Foundations and the Terrain on page 717](#).

The Subfloor Height Above Terrain distance is stated and can be modified in the Terrain Specification dialog. You can specify a custom value to produce a daylight or walkout basement. See [General Panel on page 1259](#).

## BUILD TERRAIN

 Select **Terrain> Build Terrain** to generate the terrain surface based on the elevation data you have provided. Build Terrain also updates the Building Pad Elevation value in the Terrain Specification dialog. See [Building the Terrain on page 1256](#).

## AUTO REBUILD TERRAIN

By default, terrain will automatically build any time a 3D view is created, ensuring that the terrain in the view is up-to-date. If your terrain is large and/or highly detailed and has not been modified, and you find that this unnecessarily slows down the generation of 3D views, consider turning this behavior off in the Terrain Specification dialog. See [General Panel on page 1259](#).

When Auto Rebuild Terrain is turned off, the Auto Rebuild Terrain  icon will follow your mouse pointer. See [Pointer Icons on page 16](#).

## CLEAR TERRAIN



To remove the generated terrain contours, select **Terrain> Clear Terrain**. When the terrain is cleared, contours do not display in 3D and contour lines do not display in plan view.

**Clear Terrain** does not remove the terrain perimeter, elevation data, or terrain features from the model. Rather, it deletes all program-generated 2D contour lines and 3D contours.

## TERRAIN SURFACE TRIANGLES

Chief Architect generates 3D terrain surfaces by dividing them into triangles. The size of the triangles determines how detailed contour lines and terrain surfaces in the 3D model can be. You can specify triangle size in the Terrain Perimeter Specification dialog. See [General Panel on page 1259](#).

Increasing the triangle count decreases triangle size, yielding more detailed contour lines and a better 3D approximation of the terrain. Smaller triangles demand longer terrain generation time and increased memory requirements. If you select a large number of small triangles for a large site, you may wait a long time for the calculation.

Decreasing the triangle count increases triangle size. Elevation lines are sampled less frequently, speeding up terrain generation. If you specify a small number of triangles for a plan with detailed elevation data, contour lines and 3D surfaces may not generate correctly.

 When a large terrain perimeter is used, consider increasing the Triangle Count to help make sure all Elevation Data and Terrain Modifiers generate contours.

---

# Elevation Data Tools



Select **Terrain> Elevation Data** to add elevation information to your terrain.

When terrain is generated, this data is used to calculate the surface of your site and is represented by contour lines in plan view and a curved surface in 3D. See [Displaying Terrain on page 1256](#).

Elevation data can be specified using the **Elevation Point** , **Elevation Line** , **Elevation Spline** , **Elevation Region** , and **Terrain Break**  tools.

Elevation data can also be imported. See [Importing Elevation Data on page 1276](#).

The elevation of each Elevation Line, Spline, and Region is specified relative to sea level.

In order to create rising and/or falling terrain, multiple terrain data objects with different elevation values must be used. If only one terrain data object is placed, the terrain will be flat regardless of the object's specified elevation.

 To avoid unexpected results, do not draw Elevation Data objects - including Terrain Breaks - with different elevation information at the same location.

## ELEVATION POINTS

 An **Elevation Point** contains the absolute elevation data for one point in the terrain model. Typically, Elevation Points are imported rather than placed manually.

Chief Architect requires many points to make an accurate approximation of your site. Even small sites may require over a hundred points to generate an accurate model of the terrain if it is sloped. For the sake of illustration, the following example shows only a few elevation points.

### To place an elevation point

1. Select **Terrain> Elevation Data> Elevation Point**  and click in plan view at the point where you would like to place elevation data. See [Place Point on page 296](#).
2. The Elevation Point Specification dialog opens. Enter an elevation value and click **OK**. See [Elevation Point Specification Dialog on page 1263](#).
3. Click somewhere else in plan view and the Elevation Point Specification dialog opens again with the last elevation value entered.

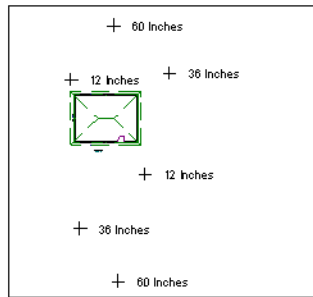

4. Repeat steps 1, 2 and 3 to place additional elevation points with varied elevation values as needed.
5. Select **Terrain> Build Terrain** . See [Building the Terrain on page 1256](#).

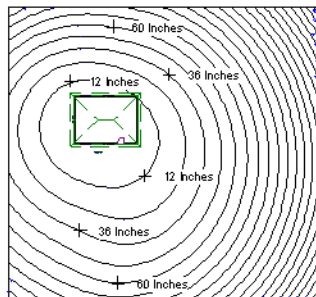



 Elevation Points are most effective when they are imported. When adding elevation data manually, use Elevation Lines and Splines instead. See [Importing Elevation Data on page 1276](#).

## ELEVATION LINES

<sup>1</sup>—  
<sup>2</sup>—  
<sup>3</sup>— An **Elevation Line** contains absolute elevation data for many points along a line at a constant elevation. Elevation lines can be connected to create a polyline with many straight sections. For the sake of illustration, the images in the following example show single-section elevation lines.

### *To draw an elevation line*

1. Select **Terrain > Elevation Data > Elevation Line** , then click and drag a line inside the Terrain Perimeter in plan view.
2. Click on the elevation line to select it, then click the **Open Object**  edit button.
3. At first, an elevation line is at elevation 0' - 0". In the Elevation Line Specification dialog, specify the desired elevation and click OK. See [Elevation Line/Region Specification Dialog on page 1264](#).
4. Repeat steps 2 and 3 to draw additional elevation lines as needed.

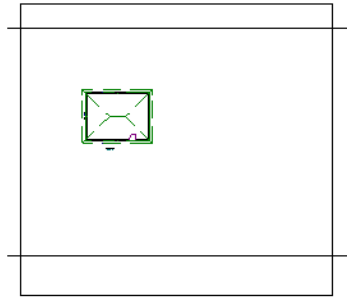

5. Select **Terrain > Build Terrain** . See [Building the Terrain on page 1256](#).

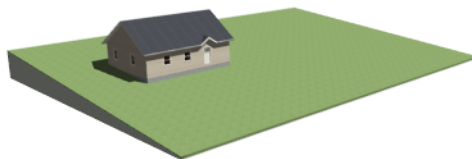
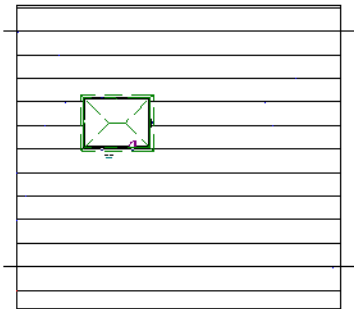

After it is drawn, an Elevation Line can be edited much the way other line-based objects can. See [Editing Line-Based Objects on page 216](#).



## ELEVATION SPLINES

 **Elevation Splines** can be used to form complex curves and shapes. Like elevation lines, elevation splines contain absolute elevation data for many points along a constant elevation.

To place an elevation spline, select **Terrain> Elevation Data> Elevation Spline**  and click and drag multiple sections in plan view. See [Splines on page 324](#).

Elevation splines are initially placed at elevation 0' - 0" and must be opened and assigned an elevation. See [Elevation Line/Region Specification Dialog on page 1264](#).

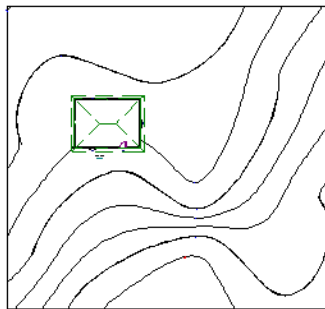
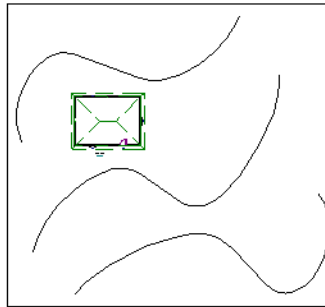

After it is drawn, an Elevation Spline can be edited much the way other spline-based objects can. See [Editing Spline-Based Objects on page 235](#).

## ELEVATION REGIONS





An **Elevation Region** contains absolute elevation data for an enclosed region and is ideal for creating a flat surface in your terrain.

Elevation Regions are similar to Flat Regions in that they produce an area with a flat surface; however, they differ in that an Elevation Region affects the contours of the terrain outside its perimeter and may also have some sloping within its perimeter. See [Flat Regions on page 1252](#).

### ***To create an elevation region***

1. Select **Terrain> Elevation Data> Elevation Region** .
2. There are two ways to add a Terrain Modifier to your plan:
  - Click once to place an 8' (0.6 m) square feature at that location.
  - Click and drag from end-to-end to draw a feature sized as needed. See [Rectangular Polyline on page 319](#).

3. Click on the region to select it, then click the **Open Object**  edit button.
4. At first, an elevation line is at elevation 0' - 0". In the Elevation Region Specification dialog, specify the desired elevation and click OK. See [Elevation Line/Region Specification Dialog on page 1264](#).
  - Click once to place an 8' (0.6 m) square feature at that location.
  - Click and drag from end-to-end to draw a feature sized as needed. See [Rectangular Polyline on page 319](#).
1. Click on the region to select it, then click the **Open Object**  edit button.
2. At first, an elevation line is at elevation 0' - 0". In the Elevation Region Specification dialog, specify the desired elevation and click OK. See [Elevation Line/Region Specification Dialog on page 1264](#).

After it is drawn, and Elevation Region can be reshaped much the way other closed polyline-based objects can. See [Editing Closed Polyline-Based Objects on page 228](#).

An **Elevation Region**  can also be created by drawing a closed polyline using **Elevation Lines** .

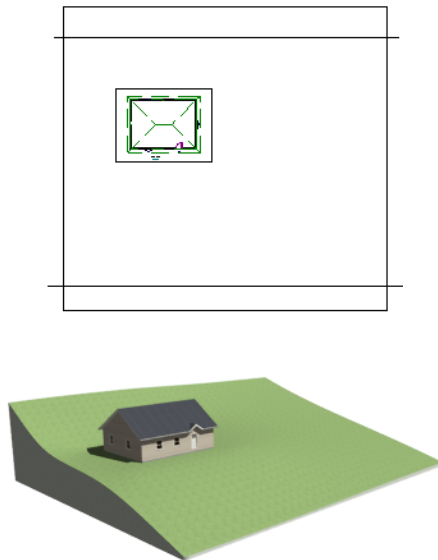



## TERRAIN BREAKS

 A **Terrain Break** creates a division along the terrain surface that affects terrain generation. Elevation data on one side of the terrain break does not affect the terrain generation on the other side, allowing you to create immediate drops in terrain.

To place a Terrain Break, select **Terrain> Elevation Data> Terrain Break**  and click and drag a line in plan view.

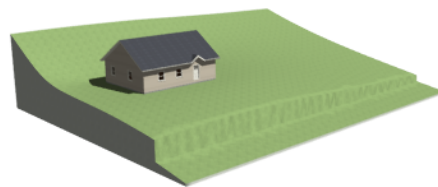
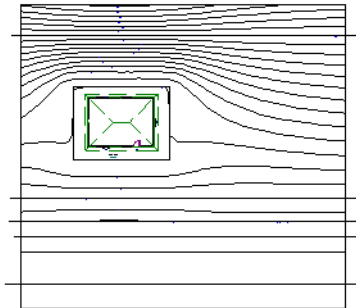
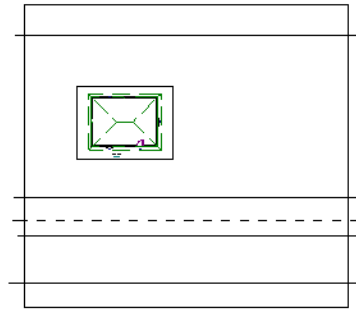
- If the Terrain Break divides the terrain perimeter into two separate pieces, the terrain data on either side is calculated independently and smoothed separately, resulting in sharp terrain contours.
- If the Terrain Break does not extend completely from one side of the terrain perimeter to the other, the areas near each end of the Terrain Break are blended.



The **Retaining Wall**  tool creates a similar effect by drawing a Terrain Break as well as a retaining wall that rests against the break. By default, the top height of the retaining wall matches the terrain on the high side of the break and the bottom matches the low side. See *Terrain Wall and Curb Tools on page 1254*.



---

## Terrain Modifier Tools

 Select **Terrain > Modifier** to access tools that allow you to modify the existing elevation data by drawing a closed polyline. Their height is relative to the terrain surface generated from the Elevation Data provided in your plan.

The elevation data associated with a Terrain Modifier only affects the terrain within its perimeter. The rest of the terrain is unaffected.

### RAISED AND LOWERED REGIONS

  The **Raised Region** tool creates a raised area with a top surface that is flattened like a plateau but follows the surface of the terrain. The **Lowered Region** tool creates a depression with a bottom that follows the terrain and is flattened.

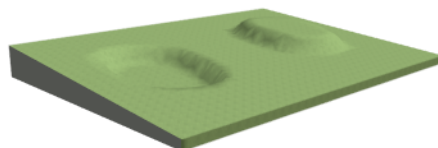

## HILLS AND VALLEYS



The **Hill** and **Valley** tools create raised and lowered areas in the terrain that come to a point rather than flattening at their highest or lowest elevations.

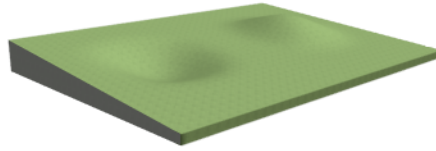

## FLAT REGIONS



The **Flat Region** tool creates an area with a surface that is flattened like a plateau but is level rather than following the contours of the terrain.

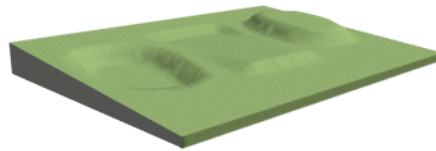

There are two ways to add a Terrain Modifier to your plan:

- Click once to place a modifier with endpoints that form a 10' (4 m) square at that location.
- Click and drag from end-to-end to draw a feature sized as needed. See [Rectangular Polyline on page 319](#).

Terrain Modifiers can only be drawn when a Terrain Perimeter is present, and will only display in 3D when they are drawn within the perimeter. See [Displaying Terrain on page 1256](#).

Once created, Terrain Modifiers can be selected and edited in a variety of ways. See [Editing Spline-Based Objects on page 235](#).



Terrain modifiers can be blocked with images and stored in the library for future use. See [Creating Architectural Blocks on page 1008](#).

---

## Terrain Features

Terrain Features are useful for creating landscaping features that follow the contours of the terrain and have a specified height, thickness, and material. Terrain Features can, for example, be used to create paths and planting beds with gravel or mulch materials that stand out in a grassy Terrain Perimeter.

Terrain Features can be drawn in both plan and camera views, but only when a Terrain Perimeter is present. Although they can be drawn beyond the extents of the terrain, in 3D views they only display within it. See [Displaying Terrain on page 1256](#).

Terrain Features can be drawn in either of two ways: click-to-create and clicking and dragging. See [Creating Objects on page 164](#).

Terrain Features can also be converted from closed 2D CAD polylines or splines using the **Convert Polyline**  edit tool. See *Convert Polyline on page 262*.





Once created, Terrain Features can be edited into nearly any shape you need. See *Editing Closed Polyline-Based Objects on page 228* and *Editing Spline-Based Objects on page 235*.

You can specify a Terrain Feature's material and height in its specification dialog. See *Terrain Feature Specification Dialogs on page 1268*.

 Terrain features can be blocked with architectural objects such as exterior fixtures and stored in the library for future use as planting beds. See *Creating Architectural Blocks on page 1008*.





## TERRAIN FEATURE TYPES

There are different types of Terrain Feature tool, all accessible in the Terrain menu. Each is designed to efficiently draw specific types of features:

-  The **Terrain Feature Tools** create general-purpose features with a concrete material. Terrain Holes are a special Terrain Feature that create a hole in the terrain rather than apply a material over it.
-  The **Garden Bed Tools** place features with a surface material and height typical of planting beds. In addition, you can choose to distribute copies of a plant image within a Garden Bed. See *Distributed Plant Panel on page 1269*.
-  The **Grass Region Tools** create regions of realistic generated 3D grass. See *Grass Region Specification Dialog on page 1270*.
-  The **Water Feature Tools** create ponds and streams with material and height attributes typical of bodies of water. While Ponds are Terrain Features, Streams are a special type of Terrain Curb with a water material. See *Terrain Wall and Curb Tools on page 1254*.
-  The **Stepping Stone Tools** can be used to create a walkway made of individual stepping stones with material and height attributes typical of walking paths.

## POLYLINE FEATURES





Most Terrain Feature parent tools have a Polyline Feature child tool that creates rectangular-shaped polyline features that can then be edited into a wide variety of shapes. Polyline Features created with a single click initially measure 10' (4 m) per side. See *Editing Closed Polyline-Based Objects on page 228*.

-  **Rectangular Feature**
-  **Terrain Hole**
-  **Polyline Garden Bed**
-  **Polyline Grass Region**
-  **Polyline Stepping Stone**

## ROUND FEATURES





All Terrain Feature parent tools have a Round Feature child tool that creates spline-based features that are roughly circular in shape with smoothly curved corners. Round Features created with a single click are initially about 150 square feet (13.6

square meters). See [Editing Spline-Based Objects on page 235](#).

-  **Round Feature**
-  **Round Garden Bed**
-  **Round Grass Region**
-  **Round Pond**
-  **Round Stepping Stone**



## KIDNEY SHAPED FEATURES

Most Terrain Feature parent tools have a Kidney Shaped Feature child tool that creates spline-shaped features with smoothly curved corners and a right angle bend in their shape. Kidney Shaped Features created with a single click are initially about 67 square feet (6 square meters). See [Editing Spline-Based Objects on page 235](#).

-  **Kidney Shaped Feature**
-  **Kidney Shaped Garden Bed**
-  **Kidney Shaped Grass Region**
-  **Kidney Shaped Pond**

## TERRAIN HOLES

By default, the program automatically cuts a hole in the terrain around any structures located within and on the same floor as the Terrain Perimeter. The shape of these holes follow the exterior surfaces of the walls and will automatically update if any of those walls are moved.

-  If you prefer to manually control the holes around structures, select the Terrain Perimeter and click the **Make Terrain Hole(s) Around Building(s)** edit button. This edit tool creates a Terrain Feature polyline with **Make Hole** checked in its specification dialog around each building on the same floor level as the Terrain Perimeter. See [Terrain Perimeter on page 1244](#).
-  The **Terrain Hole** tool allows you to draw Terrain Feature polylines with **Make Hole** specified, as well. See [Terrain Feature Specification Dialogs on page 1268](#).

---

## Terrain Wall and Curb Tools

 Select **Terrain> Terrain Wall and Curb** to draw landscaping walls and curbs that follow the contours of the terrain.

Straight and curved Terrain Walls and Curbs are drawn just as other walls are. See [Creating Walls on page 357](#).

Terrain Walls and Curbs are examples of Terrain Paths. Other examples include Sidewalks and Streams. See [Terrain Path Specification Dialog on page 1273](#).

## TERRAIN WALLS



Use the **Straight Terrain Wall** tool to draw a wall that sits on top of and follows the terrain.



Use the **Spline Terrain Wall** to draw a curved terrain wall. This wall is drawn the same way as a CAD Spline. See *Splines on page 324*.

Once drawn, a Terrain Wall can be like other line-based objects. See *Editing Line-Based Objects on page 216* and *Editing Spline-Based Objects on page 235*.

Terrain walls are 5' (1500 mm) high and concrete by default, but you can specify the material, height and more in the Terrain Path Specification. See *Terrain Path Specification Dialog on page 1273*.

## RETAINING WALLS

The **Retaining Wall** tools function similarly to Terrain Breaks, but include a wall. See *Terrain Breaks on page 1250*.



Use the **Straight Retaining Wall** tool draws a straight wall that holds back sloped terrain.



Use the **Curved Retaining Wall** tool to draw a curved retaining wall.

A Retaining Wall's height is determined by the elevation of the terrain on each side. By default, the height of the wall matches the terrain on the high side of the break and the bottom matches the low side. If you insert a Retaining Wall into flat terrain, it looks like a concrete strip in 3D views.

Once drawn, a Retaining Wall can be edited much like other walls. See *Editing Walls on page 368*.

## TERRAIN CURBS

Terrain Curbs are useful for creating curbs around planting beds and along paths.



Use the **Straight Terrain Curb** tool to draw a straight landscaping curb.



Use the **Spline Terrain Curb** tool to draw a curved landscaping curb. This curb is drawn the same way as a CAD Spline. See *Splines on page 324*.

Once drawn, a Terrain Curb can be like other line- and spline-based objects. See *Editing Line-Based Objects on page 216* and *Editing Spline-Based Objects on page 235*.

You can specify the height of straight and spline terrain curbs on the GENERAL panel of the Terrain Path Specification. See *Terrain Path Specification Dialog on page 1273*.



You can also add Fencing to your terrain, complete with gates from the Doors Library. See *Fencing Tools on page 351*.

## STREAMS



Streams are a special type of spline-based Terrain Curb with a water material. Select **Terrain > Water Feature >** to access the **Stream** tool. See *Terrain Features on page 1252*.

Streams follow the contours of the terrain, so for best results try to draw them so they follow a downhill course for their entire length.

---

## Terrain Objects in the Library



The Library Browser contains a variety of objects that can be placed in a plan's terrain, including plants, exterior fixtures, accessories and roadway objects. See [The Library Browser on page 946](#).

---

## Displaying Terrain



The display of terrain objects in 2D and 3D views is controlled in the Layer Display Options dialog. See [Layer Display Options Dialog on page 179](#).

### IN PLAN VIEW

Like other objects, terrain objects are placed in Drawing Groups that affect whether they display in front of or behind other objects. You can modify a selected object's place in the drawing order by clicking the **View Drawing Group Edit Tools**  edit button. See [Drawing Group Edit Tools on page 190](#).

You can customize appearance of Terrain Features, Roads, and other terrain objects in plan view by changing their line and fill styles. See [Line Styles on page 199](#) and [Fill Styles on page 192](#).

Plant images are represented in plan view by 2D CAD symbols. You can select a plant's symbol in the Plant Image Specification dialog. See [Image Panel on page 1298](#).

Sun Shadows are generated by the program and represent shadows cast at a particular location on the Earth and at a specific date and time. These shadows are computed based on the contour of the terrain and can be represented by an automatically-generated CAD polyline in plan view. See [Sun Angles and Shadows on page 1143](#).



### BUILDING THE TERRAIN



When terrain is generated, Chief Architect gathers all elevation data that has been added to the model and creates a terrain surface. The program interpolates the data to produce smooth contours.

A terrain perimeter with no additional elevation data drawn within it generates terrain that is flat at the elevation 0' - 0", or sea level.

By default, the terrain is automatically built before a 3D view is generated and when a Sun Shadow is created. This process takes a variable amount of time, depending on the amount of elevation data and number of terrain features in the plan. The Building Terrain progress dialog displays as terrain is generated, sometimes only briefly, indicating the progress.

You can turn off **Auto Rebuild Terrain** in the Terrain Specification dialog as well as in the Sun Angle Specification dialog, and rebuild the terrain manually only when needed by selecting **Terrain > Build Terrain** . When **Auto Rebuild Terrain** is turned off and the terrain is not up-to-date, the Build Terrain  icon displays near your mouse pointer. See [Terrain Specification Dialog on page 1258](#) and [Earth Data Panel on page 1146](#).

### CONTOUR LINES

When elevation data has been drawn or imported into a plan, contour lines will display in plan views. See [Elevation Data Tools on page 1246](#).



Chief Architect Premier can produce both primary and secondary contours. They are on two different layers so you can control their display separately. Contour line labels use the Text Styles assigned to the “Terrain, Primary Contours” and “Terrain, Secondary Contours” layers.

By default, all contour lines are set to be primary, but you can specify secondary contours, frequency and other attributes of contour lines in the Terrain Specification dialog. See [Contours Panel on page 1260](#).

## TERRAIN AND ROAD LABELS

Labels for terrain objects - including the Terrain Perimeter, most Elevation Data objects, Terrain Features, Terrain Modifiers, Terrain Paths, and Roads - display in plan view when the “Terrain Labels” layer is turned on. Labels for all but Elevation Data, Terrain Modifiers, and Road Markings can display in cross section/elevation views, as well. See [Label Panel on page 700](#).

With the exception of Elevation Lines, Splines, and Regions, the Automatic Labels for terrain objects are blank; however, you can specify a custom label in their specification dialogs.

## IN 3D VIEWS

In order for objects such as Terrain Features and Roads to be visible in 3D views, they must be drawn within the Terrain Perimeter. Any portions of these objects drawn outside the Terrain Perimeter will not be seen in 3D views. See [Terrain Features on page 1252](#).

A variety of tools are available to help you adjust the perspective of your 3D views. See [Editing 3D Views on page 1105](#).

Note: The generated 3D grass in Grass Regions does not display in CPU Ray Trace views. See [CPU Ray Tracing on page 1167](#).

## TERRAIN AND 3D DRAWING TIME

Terrain is typically large with many surface triangles, which often increases the drawing time of 3D views. The time required is affected by the quality of the terrain, the amount of elevation data and number of terrain features present. For information about surface triangles and how they influence terrain quality, see [General Panel on page 1259](#).

Lights and symbols can be placed outdoors and included in 3D views when the terrain is generated. These objects can also contribute to the time needed to generate 3D views. See [Rendering Tips on page 1132](#).

## IN SCHEDULES

Terrain and Road objects can be included in schedules. See [The Schedule Tools on page 682](#).

By default, the Terrain Perimeter, Driveways, Medians, Roads, and Road Markings are listed in schedule categories of the same names; Sidewalks, Terrain Walls, and Terrain Curbs are listed in the "Terrain Paths" category; and Terrain Features, Terrain Modifiers, Garden Beds, Water Features, and Stepping Stones are listed in the "Terrain Features" category. You can, however, assign a selected object to the category of your choice in its specification dialog. See [Schedule Panel on page 704](#).

---

# Editing Terrain Objects

Before a terrain object can be edited, it must be selected. All terrain objects can be selected in plan view. In addition, the Terrain Perimeter and Terrain Features can be selected in 3D views. See [Selecting Objects on page 210](#).

A selected terrain object can be edited using its edit handles, edit tools and specification dialog. See [Specification Dialogs on page 21](#).

Any time elevation data is changed, the terrain must be rebuilt. This can be done by selecting **Terrain> Build Terrain** , and occurs automatically when a 3D view is created.

## USING THE EDIT HANDLES

Terrain objects can be moved, resized, and reshaped using their edit handles. How a selected object can be edited depends on what type of object it is. See *Editing Objects on page 205*.

- The Terrain Perimeter can be moved, resized, and reshaped like a polyline-based objects.
- Elevation Points can be moved in plan view using the Move edit handle.
- **Elevation Lines, Elevation Splines** and **Terrain Breaks** are edited like other line- and spline-based objects.
- The shape of a **Raised Region, Lowered Region, Hill, Valley**, and **Flat Region** can be edited like a spline.
- Terrain Features are edited like other spline- and polyline-based objects.
- In plan view, terrain object labels also have a small square Move edit handle and small rectangular Rotate handle.

## USING THE EDIT TOOLS

A selected terrain object can be edited in a variety of ways using the buttons on the Edit Toolbar. The edit tools available for a terrain object depends on the type of object selected. See *The Edit Toolbar on page 130*.

Note: If you copy terrain objects from one plan to another, you cannot view the pasted objects in 3D unless a Terrain Perimeter exists.

## USING DIMENSIONS



Like many other types of objects, terrain objects can be resized and moved using dimensions. For more information see *Moving Objects Using Dimensions on page 483*.

---

# Terrain Specification Dialog

The Terrain Specification dialog controls how your terrain is modeled, as well as its appearance. It can be accessed in any of three ways:



Select **Terrain> Terrain Specification**;



Select the Terrain Perimeter and click the **Open Object** edit button;



Double-click the Terrain Perimeter using the **Select Objects** tool.

## GENERAL PANEL

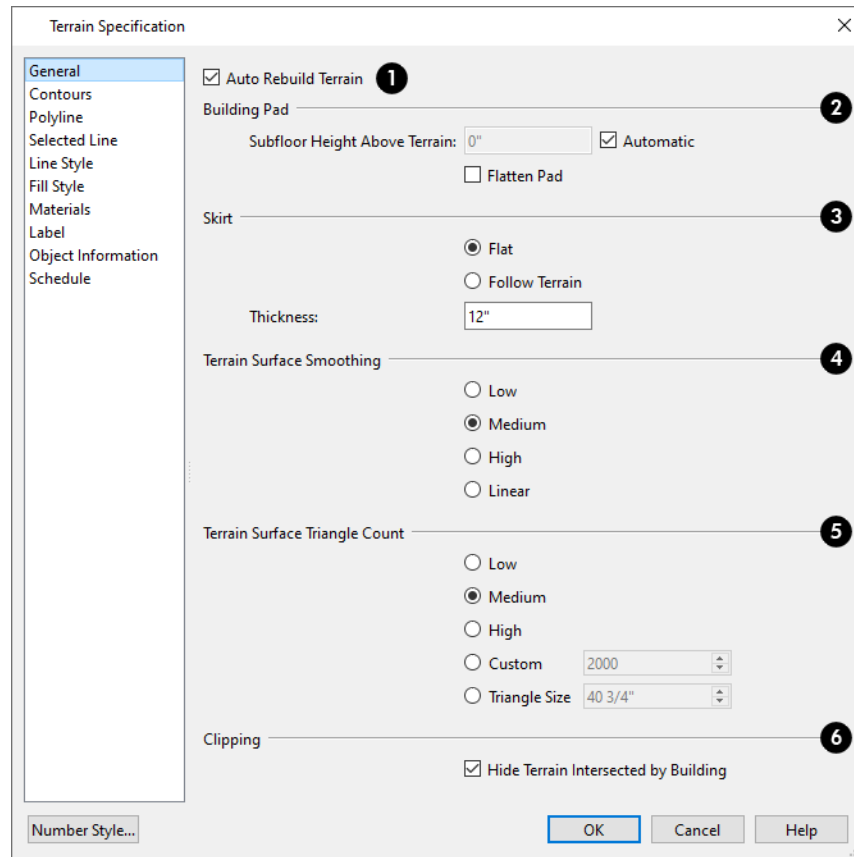

### 1 Auto Rebuild Terrain

Check **Auto Rebuild Terrain** to automatically rebuild terrain to reflect recent changes before generating a 3D view or a Sun Shadow. If this option is unchecked and the terrain is not up-to-date, the Rebuild Terrain  icon displays near your mouse pointer. See [Building the Terrain on page 1256](#).

### 2 Building Pad

Specify how the **Building Pad** is generated beneath the structure. See [Foundations and the Terrain on page 717](#).

- To specify the distance between Floor 1 and the terrain at the building footprint center, uncheck **Automatic** and enter a value in the **Subfloor Height Above Terrain** field.
- Check **Automatic** to have Chief Architect automatically lower the terrain relative to the first floor. See [Terrain Height vs Floor Height on page 1245](#).
- Check **Flatten Pad** to flatten the area beneath the building. To create a walkout basement, uncheck this box.

### 3 Skirt

Define the thickness of the **Skirt** added to the terrain. The skirt is only visible in 3D views and gives the viewer a sense of depth when viewing the terrain.

- **Flat** specifies that the skirt be flat at its base. Chief Architect determines the lowest point in the terrain and then offsets this value by the user specified thickness value. The resulting value is used as a uniform elevation for the base of the skirt.
- **Follow Terrain** specifies that the skirt base maintains a consistent distance below the terrain. The distance is equivalent to the specified Thickness value.

#### 4 Terrain Surface Smoothing

The **Terrain Surface Smoothing** settings control the amount of curvature applied to terrain edges.

- **Low** produces terrain that has sharp peaks and abrupt changes in slope, while **High** results in terrain that flows continuously from point to point but may take longer to generate.
- Select **Linear** to apply no smoothing to the Terrain. Instead, flat triangular surfaces are created between elevation points. This option is only recommended when large amounts of closely spaced elevation data is present.

#### 5 Triangle Count

Specify the number of surface triangles used to generate the terrain in 3D views. A lower count value will generate more quickly but have reduced quality.

- Specify a **Custom** triangle count value.
- Specify the maximum **Triangle Size** in the terrain surface. Smaller triangles produce better quality results in 3D but take longer to generate.

Chief Architect builds 3D terrain surfaces by splitting them into triangles. See *Terrain Surface Triangles on page 1246*.

Triangles are computed roughly as follows:

Size of Triangle = Area of Terrain Perimeter / Number of Triangles

The Low (1000), Medium (2000), and High (4000) values work well for a terrain perimeter of approximately 20,000 sq ft (1858 m<sup>2</sup>). If your terrain perimeter varies greatly from this, consider defining the number of triangles using the **Custom** setting or the **Triangle Size** setting.

#### 6 Clipping

Check **Hide Terrain Intersected by Building** to cut out the portion of the terrain that is intersected by the first floor footprint. Checking this box prevents the generation of contour lines inside the house.

If your foundation footprint differs from your first floor footprint, you may need to use the **Terrain Hole**  tool for custom clipping instead. See *Terrain Features on page 1252*.

### CONTOURS PANEL

Chief Architect Premier identifies two types of contour lines: Primary and Secondary. They are drawn on different layers, so you can control how they display in plan view. See *Contour Lines on page 1256*.

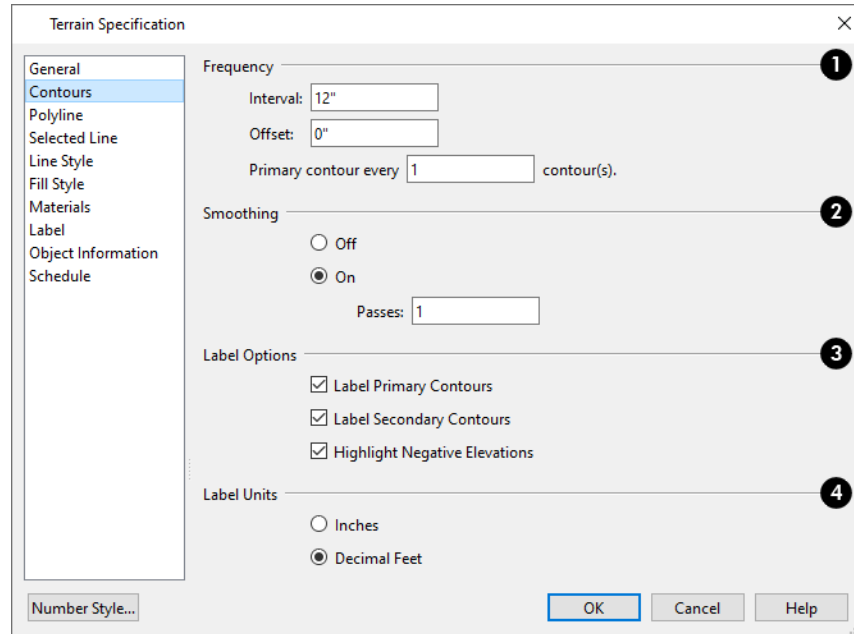

### 1 Frequency

Specify the **Frequency** at which contour lines are generated.

- Define the **Interval** between contour lines, which is the change in elevation between contours. If the interval is set to 12”, a contour line is computed for each elevation change of 12”.
- Specify the **Offset** value. When the Offset is 0, a contour line will be drawn at zero elevation and additional contours will generate based on the Interval value. If the Offset is changed to 5, a contour line will be drawn 5 units from zero elevation rather than at 0, and additional contours will generate from there.
- **Primary contour every\_\_contours** - Specify the interval for primary contours. A value of 1 produces only primary contours, while a value of 5 defines every fifth contour line as a primary contour.

### 2 Smoothing

If contour **Smoothing** is turned on, Chief Architect attempts to remove sharp bends and jagged sections from the 2D contour lines.

- Specify the number of **Passes** to perform when smoothing. The more passes, the smoother the contour lines become, but contours become less accurate.

### 3 Label Options

Control the display of **Contour Labels** in plan view.

- Check **Label Primary Contours** to label primary contour lines with their elevation data using the Units specified below.
- Check **Label Secondary Contours** to label secondary contour lines with their elevation data.
- Check **Highlight Negative Elevations** to display labels of contour lines with elevations below 0 in red. When unchecked, they use the color set in the Text Style assigned to their layer.

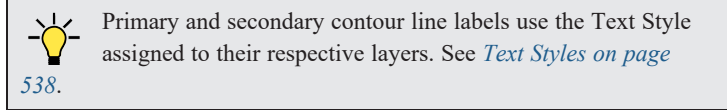

#### 4 Label Units

Specify the **Label Units** used by contour labels. Select either **Inches** or **Decimal Feet** (**Millimeters** or **Meters** for metric).

#### POLYLINE PANEL

The POLYLINE panel states the length of the Terrain Perimeter's **Perimeter**, its enclosed **Area**, and its **Volume**.

The settings on this panel are available for a variety of other objects in the program. For information about these settings, see [Polyline Panel on page 317](#).

#### SPLINE PANEL

The SPLINE panel has a single option and is only available if the Terrain Perimeter has been converted to a spline. See [Convert to Spline on page 258](#).

New Segment Angle:

**New Segment Angle** - Specify the angle between line segments that are used to draw the spline. Specifying a smaller angle makes the spline's curvature smoother. Specify a larger angle to draw the spline faster.

#### SELECTED LINE/ARC PANEL

The SELECTED LINE panel is available when the selected edge is a line as opposed to an arc. See [Line Panel on page 304](#).

The SELECTED ARC panel is available when the selected edge has been converted into an arc. See [Arc Panel on page 312](#).

See, too, [Selected Edge on page 212](#) and [Change Line/Arc on page 256](#).

#### LINE STYLE PANEL

The settings on the LINE STYLE panel are available for a variety of other objects in the program. See [Line Style Panel on page 305](#).

#### FILL STYLE PANEL

The settings on the FILL STYLE panel affect the appearance of the Terrain Perimeter in plan view. See [Fill Style Panel and Dialogs on page 193](#).

#### MATERIALS PANEL

The settings on the MATERIALS panel let you specify the terrain surface and terrain skirt materials used in 3D views. These materials are not calculated in the Materials List. See [Materials Panel on page 1055](#).

#### LABEL PANEL

The Terrain Perimeter label displays in floor plan and cross section/elevation views when the "Terrain Labels" layer is turned on and use the Text Style assigned to that layer. In order for the label to display in a cross section/elevation view, the camera must be located outside the Terrain Perimeter so the surface of the skirt is visible. See [Terrain and Road Labels on page 1257](#).

For more information, see [Label Panel on page 700](#).

## OBJECT INFORMATION PANEL

The information entered on the OBJECT INFORMATION panel can be used in schedules and the materials list. For more information, see [Object Information Panel on page 1331](#).

## SCHEDULE PANEL

The settings on the SCHEDULE panel determine which schedule categories the selected object is included in. See [Schedule Panel on page 704](#).

---

# Elevation Point Specification Dialog

To open the Elevation Point Specification dialog, select an elevation point and click the **Open Object** edit button, or double-click on an Elevation Point using the **Select Objects**  tool.

Use the Elevation Point Specification dialog to define the selected elevation point and control its appearance in plan view.

## GENERAL PANEL

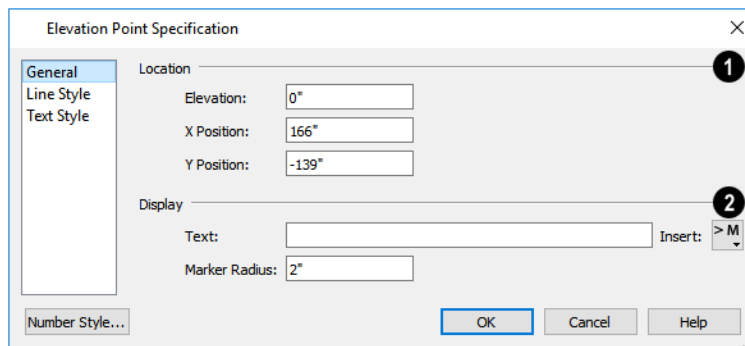

### 1 Location

Specify the exact location of the elevation point.

- Specify the **Elevation** of the selected Elevation Point.

 Click the Number Style button to specify the units of measurement used in this and other dialogs. See [Dialog Number/Angle Style Dialog on page 126](#).

- **X Position** - Enter the x coordinate of the elevation point.
- **Y Position** - Enter the y coordinate of the elevation point.

## 2 Display

- In the **Text** field, type any notes that you would like to display beside the selected Elevation Point in plan view.
- Click the **Insert Macro**  button to add a Text Macro such as %elevation% to the elevation point's text, which displays in plan view. See *Text Macros on page 540*.
- Enter the **Marker Radius**, which is the size of the point marker, measured from the center to an edge.

### LINE STYLE PANEL

The settings on the LINE STYLE panel are available for a variety of other objects in the program. For information about these settings, see *Line Style Panel on page 305*.

### TEXT STYLE PANEL

The settings on the TEXT STYLE panel control the appearance of the selected Elevation Point's text. For more information, see *Text Style Panel on page 538*.

---

## Elevation Line/Region Specification Dialog

 To open the Elevation Line or Elevation Region Specification dialog, select an Elevation Line, Spline, a polyline composed of Elevation Lines or Splines, or an Elevation Region and click the **Open Object** edit button. You can also double-click an Elevation Line/Spline using the **Select Objects**  tool.

The Elevation Line Specification dialog is used to define the selected Elevation Line /Spline and controls its appearance in plan view.

The settings in this dialog are the same as those in the Elevation Region Specification dialog. See *Elevation Regions on page 1249*.

### ELEVATION PANEL

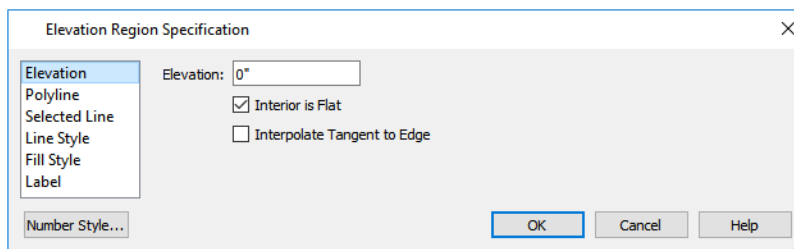

- Specify the **Elevation** of the selected Elevation Line, Spline, or Polyline.

 Click the Number Style button to specify the units of measurement used in this and other dialogs. See *Dialog Number/Angle Style Dialog on page 126*.

- Check **Interior is Flat** to maintain a flat surface at the specified Elevation. When unchecked, the perimeter of the region maintains the specified Elevation, but the interior elevation may vary depending on other elevation data in the drawing. Only available for closed Elevation Regions.



- Check **Interpolate Tangent to Edge** to flatten the terrain surface as it approaches the edges of the Elevation Region. This option is only available for closed Elevation Regions, and only when Interior is Flat is unchecked.

## POLYLINE PANEL

The POLYLINE panel states the **Length** of an open polyline or the **Perimeter** of a closed polyline. If multiple Elevation Line /Spline segments form a closed Elevation Region, its Area will be calculated. Elevation Lines /Splines do not have a thickness, so they have no Volume.

## SPLINE PANEL

The SPLINE panel has a single option and is only available when the selected object is an Elevation Spline. See [Splines on page 324](#).

New Segment Angle:

**New Segment Angle** - Specify the angle between line segments that are used to draw the spline. Specifying a smaller angle makes the spline smoother. Specify a larger angle to draw the spline faster.

## SELECTED LINE/ARC PANEL

The SELECTED LINE panel is available when the selected edge is a line as opposed to an arc. See [Line Panel on page 304](#).

The SELECTED ARC panel is available when the selected edge has been converted into an arc. See [Arc Panel on page 312](#).

See, too, [Selected Edge on page 212](#) and [Change Line/Arc on page 256](#).

## LINE STYLE PANEL

The settings on the LINE STYLE panel are available for a variety of other objects in the program. See [Line Style Panel on page 305](#).

## LABEL PANEL

Elevation Line, Polyline, and Region labels displays in plan view when the “Terrain Labels” layer is turned on and use the Text Style assigned to that layer. The default label reports the selected object’s Elevation value in feet (mm). See [Terrain and Road Labels on page 1257](#).

For more information, see [Label Panel on page 700](#).

---

# Flat Region Specification Dialog



To open the Flat Region Specification dialog, select a Flat Region and click the **Open Object** edit button, or double-click a Flat Region using the **Select Objects**  tool. See [Flat Regions on page 1252](#).

The options in the Flat Region Specification dialog are similar to those a number of other dialogs in the program.

## POLYLINE PANEL

The POLYLINE panel states the length of the region’s **Perimeter** and its enclosed **Area**. Flat Regions do not have a Volume measurement. See [Polyline Panel on page 317](#).

## SPLINE PANEL

The SPLINE panel has a single option and is only available when the selected object is a spline. See [Splines on page 324](#).

New Segment Angle:

**New Segment Angle** - Specify the angle between line segments that are used to draw the spline. Specifying a smaller angle makes the spline smoother. Specify a larger angle to draw the spline faster.

## SELECTED LINE/ARC PANEL

The SELECTED LINE panel is available when the selected edge is a line as opposed to an arc. See [Line Panel on page 304](#).

The SELECTED ARC panel is available when the selected edge has been converted into an arc. See [Arc Panel on page 312](#).

See, too, [Selected Edge on page 212](#) and [Change Line/Arc on page 256](#).

## LINE STYLE PANEL

The settings on the LINE STYLE panel are available for a variety of objects in the program. See [Line Style Panel on page 305](#).

## FILL STYLE PANEL

The settings on the FILL STYLE panel affect the appearance of the selected object in plan view. See [Fill Style Panel and Dialogs on page 193](#).

## LABEL PANEL

Labels for Flat Regions display in plan view when the “Terrain Labels” layer is turned on and use the Text Style assigned to that layer. In order to display in a cross section/elevation view, the camera must be located outside the Terrain Perimeter so the surface of the skirt is visible. See [Terrain and Road Labels on page 1257](#).

For more information, see [Label Panel on page 700](#).

## OBJECT INFORMATION PANEL

The information entered on the OBJECT INFORMATION panel can be used in schedules and the materials list. For more information, see [Object Information Panel on page 1331](#).

## SCHEDULE PANEL

The settings on the SCHEDULE panel determine which schedule categories the selected object is included in. See [Schedule Panel on page 704](#).

---

# Hill / Valley Specification Dialog



The Hill/Valley Specification defines the selected Hill or Valley and controls its appearance in plan view.

To open the Hill/Valley Specification dialog, select one or more Hills or Valleys and click the **Open Object** edit button, or double-click the region(s) using the **Select Objects**  tool.

## HILL / VALLEY PANEL

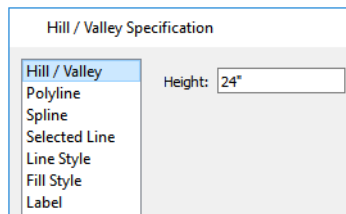

- Enter a **Height** for the selected Hill or Valley. This height is relative to the terrain surface that is generated from the Elevation Data in your plan. See [Terrain Modifier Tools on page 1251](#).

## POLYLINE PANEL

The POLYLINE panel states the length of the hill or valley's **Perimeter** and its enclosed **Area**. Hills and Valleys do not have a volume measurement.

## SPLINE PANEL

The SPLINE panel has a single option and is only available when the selected object is a spline. See [Splines on page 324](#).

New Segment Angle:

**New Segment Angle** - Specify the angle between line segments that are used to draw the spline. Specifying a smaller angle makes the spline smoother. Specify a larger angle to draw the spline faster.

## SELECTED LINE/ARC PANEL

The SELECTED LINE and/or SELECTED ARC panels are only available if the selected Hill or Valley has been converted to a polyline. See [Convert Spline to Polyline on page 266](#).

The SELECTED LINE panel is available when the selected edge is a line as opposed to an arc. See [Line Panel on page 304](#).

The SELECTED ARC panel is available when the selected edge has been converted into an arc. See [Arc Panel on page 312](#).

See, too, [Selected Edge on page 212](#) and [Change Line/Arc on page 256](#).

## LINE STYLE PANEL

The settings on the LINE STYLE panel are available for a variety of other objects in the program. See [Line Style Panel on page 305](#).

## FILL STYLE PANEL

The settings on the FILL STYLE panel affect the appearance of the selected object in plan view. See [Fill Style Panel and Dialogs on page 193](#).

## LABEL PANEL

Hill and Valley labels display in plan view when the "Terrain Labels" layer is turned on and use the Text Style assigned to that layer. Hill and Valley labels do not display in elevation views. See [Terrain and Road Labels on page 1257](#).

For more information, see [Label Panel on page 700](#).

## OBJECT INFORMATION PANEL

The information entered on the OBJECT INFORMATION panel can be used in schedules and the materials list. For more information, see [Object Information Panel on page 1331](#).

## SCHEDULE PANEL

The settings on the SCHEDULE panel determine which schedule categories the selected object is included in. See [Schedule Panel on page 704](#).

---

# Raised / Lowered Region Specification Dialog

To open the Raised/Lowered Region Specification dialog, select one or more raised or lowered regions and click the **Open Object** edit button, or double-click the region(s) using the **Select Objects**  tool.

The Raised / Lowered Region Specification dialog is similar to the Hill / Valley Specification dialog. See [Hill / Valley Specification Dialog on page 1266](#).

---

# Terrain Feature Specification Dialogs

To open the Terrain Feature Specification dialog, select one or more Terrain Features and click the **Open Object** edit button, or double-click on a Terrain Feature using the **Select Objects**  tool. A number of related objects including Ponds and Stepping Stones use this same specification dialog. See [Terrain Features on page 1252](#).

Garden Beds are also a type of Terrain Feature and have an additional DISTRIBUTED PLANT panel in their Garden Bed Specification dialog.

The panels that are available in the Terrain Feature Specification dialogs will vary, depending on the type of Terrain Feature that is selected.

## GENERAL PANEL

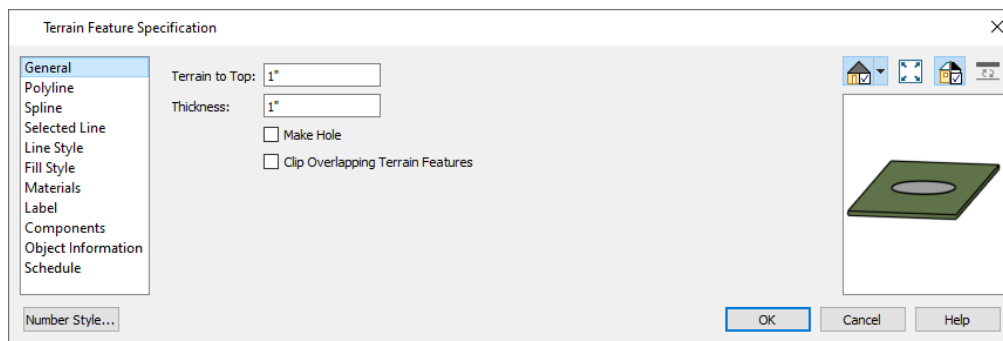

- Specify the **Terrain to Top** value, which is the distance from the top surface of the terrain to that of the terrain feature. If this value is a negative number, the feature sinks into the terrain.
- Specify the feature's **Thickness**.
- Check **Make Hole** to specify the selected Terrain Feature as a Terrain Hole. See [Terrain Holes on page 1254](#).

- Check **Clip Overlapping Terrain Features** to suppress the 3D display of any part of the selected Terrain Feature intersected by other Terrain Features with a lower Terrain to Top value. Clipping is useful for creating features that contain other features such as planters or swimming pools.

### DISTRIBUTED PLANT PANEL

This panel is only available when the selected Terrain Feature is a Garden Bed. See [Distributed Object Panel - Distribution Region on page 1044](#).

### POLYLINE PANEL

The POLYLINE panel states the length of the garden bed's **Perimeter**, its enclosed **Area**, and its **Volume**. See [Polyline Panel on page 317](#).

### SPLINE PANEL

The SPLINE panel has a single option and is only available when the selected object is a spline. See [Splines on page 324](#).

New Segment Angle:

**New Segment Angle** - Specify the angle between line segments that are used to draw the spline. Specifying a smaller angle makes the spline smoother. Specify a larger angle to draw the spline faster.

### SELECTED LINE/ARC PANEL

The SELECTED LINE panel is available when the selected edge is a line as opposed to an arc or when the selected object is a spline. See [Line Panel on page 304](#).

The SELECTED ARC panel is available when the selected edge has been converted into an arc. See [Arc Panel on page 312](#).

See, too, [Selected Edge on page 212](#) and [Change Line/Arc on page 256](#).

### LINE STYLE PANEL

The settings on the LINE STYLE panel are available for a variety of other objects in the program. See [Line Style Panel on page 305](#).

### FILL STYLE PANEL

The settings on the FILL STYLE panel affect the appearance of the selected object in plan view. See [Fill Style Panel and Dialogs on page 193](#).

### MATERIALS PANEL

The settings on the MATERIALS panel affect the appearance of the selected object in 3D views. See [Materials Panel on page 1055](#).

### LABEL PANEL

Terrain Feature labels display in floor plan and cross section/elevation views when the "Terrain Labels" layer is turned on and use the Text Style assigned to that layer. In order for the label to display in a cross section/elevation view, the feature's Terrain to Top value must be a positive value and the camera must be located outside the feature's perimeter so a side surface is visible above the terrain. See [Terrain and Road Labels on page 1257](#).

For more information, see *Label Panel on page 700*.

## COMPONENTS PANEL

The information on the COMPONENTS panel can be used in the materials list. For more information, see *Components Panel on page 1330*.

## OBJECT INFORMATION PANEL

The information entered on the OBJECT INFORMATION panel can be used in schedules and the materials list. For more information, see *Object Information Panel on page 1331*.

## SCHEDULE PANEL

The settings on the SCHEDULE panel determine which schedule categories the selected object is included in. See *Schedule Panel on page 704*.

---

# Grass Region Specification Dialog

To open the Grass Region Specification dialog, select one or more Grass Regions and click the **Open Object** edit button, or double-click a Grass Region using the **Select Objects**  tool.

The settings in this dialog are similar to those in the Grass Region Defaults dialog.

Most of the panels in this dialog are similar to those for a variety of other objects in the program.

The Grass Region Specification dialog has the following panels:

## GENERAL PANEL

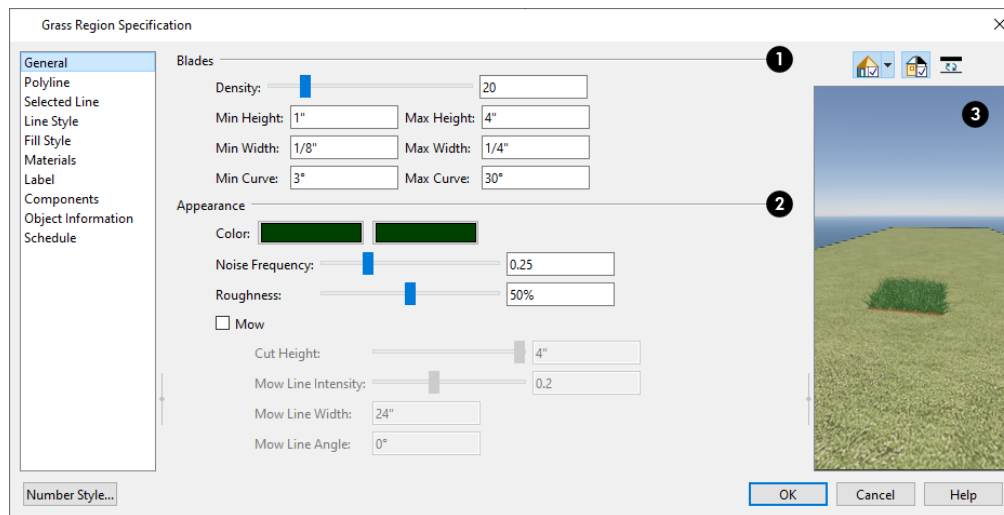

### 1 Blades

Specify the physical attributes of the selected region's blades of grass.

- Specify the **Density** value, which controls how closely the blades of grass are to one another.
- Specify the grass blades' **Minimum** and **Maximum Height**.
- Specify the grass blades' **Minimum** and **Maximum Width**.
- Specify the grass blades' **Minimum** and **Maximum Curve**. A value of 0° produces grass blades that are completely straight.

## 2 Appearance

- Specify the **Color** values, which are the colors assigned to the grass blades.
- Specify the **Noise Frequency**, which is the amount of speckled light reflected off the grass blades.
- Specify the **Roughness** of the grass blades. Adjusting this value can also affect the appearance of lighting noise in some scenes.
- Check **Mow** to clip the pointed ends of the tallest grass blades so they have a straight top edge and enable the settings that follow:
  - Specify the grass blades' **Cut Height**, which is the height at which the tallest blades are clipped.
  - Specify the **Mow Line Intensity**, which is the degree to which all grass blades are cut to the Cut Height.
  - Specify the **Mow Line Width**, which defines the variance in height that grass blades may have.
  - Specify the **Mow Line Angle**, which is the cut angle on the blades of grass.

## 3 Preview

A preview of the selected Grass Region displays on the right side of the panel. The Vector View Rendering Techniques is not available for Grass Regions. See [Dialog Preview Panes on page 22](#).

### POLYLINE PANEL

The POLYLINE panel states the length of the region's **Perimeter**, its enclosed **Area**, and more. See [Polyline Panel on page 317](#).

### SPLINE PANEL

The SPLINE panel has a single option and is only available when the selected region is a spline. See [Splines on page 324](#).

New Segment Angle:

**New Segment Angle** - Specify the angle between line segments that are used to draw the spline. Specifying a smaller angle makes the spline smoother. Specify a larger angle to draw the spline faster.

### SELECTED LINE/ARC PANEL

The SELECTED LINE panel is available when the selected edge is a line as opposed to an arc or when the selected object is a spline. See [Line Panel on page 304](#).

The SELECTED ARC panel is available when the selected edge has been converted into an arc. See [Arc Panel on page 312](#).

See, too, [Selected Edge on page 212](#) and [Change Line/Arc on page 256](#).

## LINE STYLE PANEL

The settings on the LINE STYLE panel are available for a variety of other objects in the program. See *Line Style Panel on page 305*.

## FILL STYLE PANEL

The settings on the FILL STYLE panel affect the appearance of the selected object in plan view. See *Fill Style Panel and Dialogs on page 193*.

## MATERIALS PANEL

The settings on the MATERIALS panel affect the appearance of the soil surface located under the blades of grass in 3D views. See *Materials Panel on page 1055*.

## LABEL PANEL

Grass Region labels display in floor plan and cross section/elevation views when the “Terrain Labels” layer is turned on and use the Text Style assigned to that layer. In order for the label to display in a cross section/elevation view, the camera must be located outside the region's perimeter and the region must be located over an area of raised terrain so a side surface is visible above the terrain. See *Terrain and Road Labels on page 1257*.

For more information, see *Label Panel on page 700*.

## COMPONENTS PANEL

The information on the COMPONENTS panel can be used in the materials list. For more information, see *Components Panel on page 1330*.

## OBJECT INFORMATION PANEL



The information entered on the OBJECT INFORMATION panel can be used in schedules and the materials list. For more information, see *Object Information Panel on page 1331*.

## SCHEDULE PANEL

The settings on the SCHEDULE panel determine which schedule categories the selected region is included in. See *Schedule Panel on page 704*.

---

# Terrain Break Specification Dialog

 To open the Terrain Break Specification dialog, select a Terrain Break or group of Terrain Breaks and click the **Open Object** edit button or double-click the Terrain Break(s) using the **Select Objects**  tool. See *Terrain Breaks on page 1250*.



## GENERAL PANEL

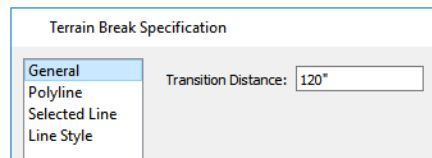

- Define the **Transition Distance**, which is the distance from the edge of the terrain break to where the break stops affecting the terrain.

## POLYLINE PANEL

The POLYLINE panel states the **Length** of an open polyline or the **Perimeter** of a closed polyline. If multiple Terrain Break segments form a closed polyline, its **Area** will be calculated. Terrain Breaks do not have a thickness, so they have no **Volume**. See *Polyline Panel on page 317*.

## SELECTED LINE/ARC PANEL

The SELECTED LINE panel is available when the selected edge is a line as opposed to an arc. See *Line Panel on page 304*.

The SELECTED ARC panel is available when the selected edge has been converted into an arc. See *Arc Panel on page 312*.

See, too, *Selected Edge on page 212* and *Change Line/Arc on page 256*.

## SPLINE PANEL

The SPLINE panel has a single option and is only available when the selected object was converted to a Terrain Break from a spline. See *Splines on page 324*.

New Segment Angle:

**New Segment Angle** - Specify the angle between line segments that are used to draw the spline. Specifying a smaller angle makes the spline smoother. Specify a larger angle to draw the spline faster.

## LINE STYLE PANEL



For information about the LINE STYLE panel, see *Line Style Panel on page 305*.

## FILL STYLE PANEL

The FILL STYLE panel is only available when multiple Terrain Break segments enclose an area. The settings on this panel affect the appearance of the closed shape in plan view. See *Fill Style Panel and Dialogs on page 193*.

---

# Terrain Path Specification Dialog

 To open the Terrain Path Specification dialog, select one or more Driveways, Sidewalks, Streams, Terrain Walls, or Terrain Curbs and click the **Open Object** edit button, or double-click the terrain path(s) using the **Select Objects**  tool. See *Terrain Wall and Curb Tools on page 1254*.

Most of the panels in this dialog are similar to those for a variety of other objects in the program.

## GENERAL PANEL

The Flare settings on the GENERAL panel are only found in the Road Specification and Driveway Specification dialogs.

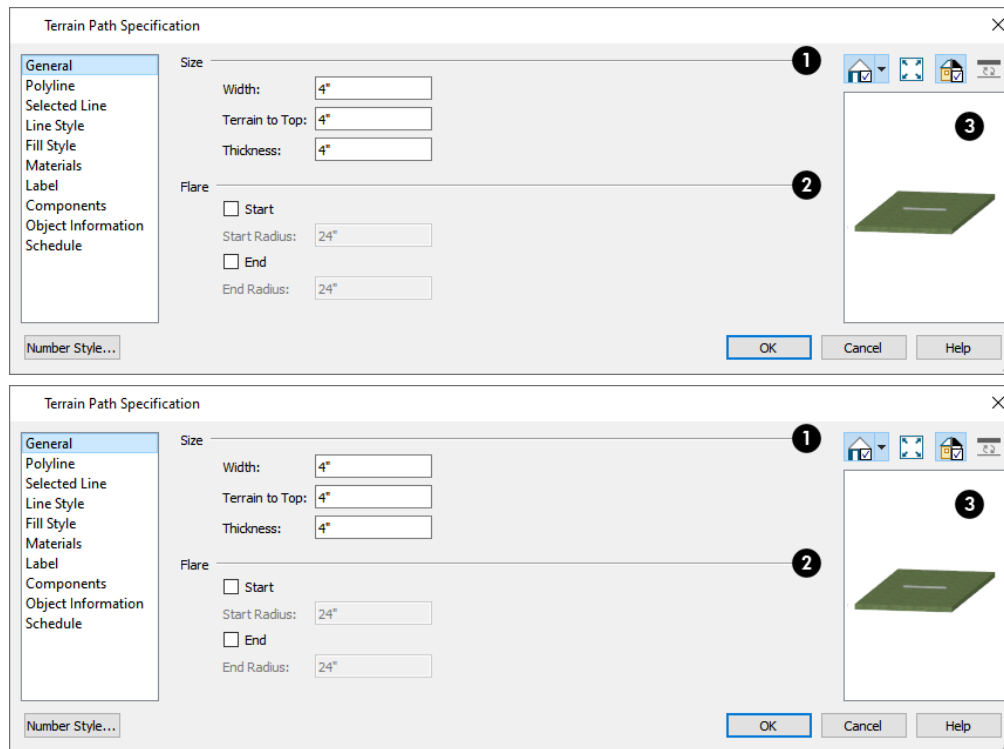

### 1 Size

- Specify the path's **Width**.
- Specify the **Terrain to Top** value, which is the distance from the top surface of the terrain to that of the path. If this value is a negative number, the object sinks into the terrain.
- Specify the path's **Thickness**.

### 2 Flare

When one terrain path joins another, you can flare the intersection.

- Check **Start** to create a flare at the starting end of the selected terrain path, then specify the **Radius** of that flare.
- Check **End** to create a flare at that end of the terrain path, then specify the Radius of that flare.

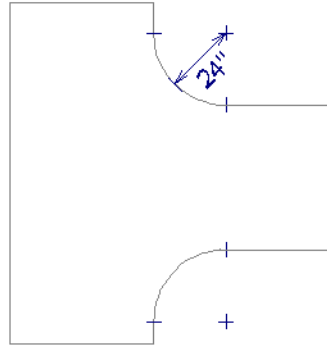

### 3 Preview

A preview of the selected cabinet displays on the right side of the panel. See [Dialog Preview Panes on page 22](#).

### POLYLINE PANEL

The POLYLINE panel states the length of the Terrain Path's **Perimeter**, its enclosed **Area**, and its **Volume**. See [Polyline Panel on page 317](#).

### SPLINE PANEL

The SPLINE panel has a single option and is only available when the selected object is a spline path. See [Splines on page 324](#).

New Segment Angle:

- **New Segment Angle** - Specify the angle between line segments that are used to draw the spline. Specifying a smaller angle makes the spline smoother. Specify a larger angle to draw the spline faster.

### SELECTED LINE/ARC PANEL

The SELECTED LINE panel is available when the selected edge is a line as opposed to an arc. See [Line Panel on page 304](#).

The SELECTED ARC panel is available when the selected edge has been converted into an arc. See [Arc Panel on page 312](#).

See, too, [Selected Edge on page 212](#) and [Change Line/Arc on page 256](#).

### LINE STYLE PANEL

The settings on the LINE STYLE panel are available for a variety of other objects in the program. See [Line Style Panel on page 305](#).

### FILL STYLE PANEL

The settings on the FILL STYLE panel affect the appearance of the selected object in plan view. See [Fill Style Panel and Dialogs on page 193](#).

### MATERIALS PANEL

The settings on the MATERIALS panel affect the appearance of the selected object in 3D views. See [Materials Panel on page 1055](#).

## LABEL PANEL

Terrain Path labels display in floor plan and cross section/elevation views when the “Terrain Labels” layer is turned on and use the Text Style assigned to that layer. In order for the label to display in a cross section/elevation view, one of the path's side surface must be visible in the view. See *Terrain and Road Labels on page 1257*.

For more information, see *Label Panel on page 700*.

## COMPONENTS PANEL

The information on the COMPONENTS panel can be used in the materials list. For more information, see *Components Panel on page 1330*.

## OBJECT INFORMATION PANEL

The OBJECT INFORMATION panel is only available for Distribution Regions. The information entered on this panel can be used in schedules and the materials list. For more information, see *Object Information Panel on page 1331*.

## SCHEDULE PANEL

The SCHEDULE panel is only available for Distribution Regions. The options this panel determines which schedule categories the selected object is included in. See *Schedule Panel on page 704*.

---

# Importing Elevation Data

Elevation data can be added to a plan using the tools and techniques described in this chapter or it can be imported from a file. See *Elevation Data Tools on page 1246*.

Chief Architect Premier can import elevation data saved in DXF/DWG, GPS Exchange (.gpx) and a variety of text file formats (.txt, .csv, .prn, .xyz, .auf and .nez). If your terrain data is not saved in one of these file formats, there are third party programs available that can convert to these formats.

## DXF/DWG FILES

If you have a model of your terrain created on another program that contains contour lines and elevation data, that information can be imported directly as elevation data into Chief Architect Premier as a .dxf or a .dwg file. See *Importing DWG/DXF Elevation Data on page 1282*.

## TEXT FILES

Elevation data can be saved in text files as x, y, and z coordinates where x and y define the location of a point on a Cartesian grid, and z defines the elevation for that point. Each data point must be on a separate line in the text file.

Importable text files can come from surveyors, other software programs, or you can create your own using a GPS system.

Elevation data saved in text files can be imported using the Import Terrain Assistant. See *Import Terrain Assistant on page 1277*.

## GPS EXCHANGE FILES

Elevation data in standard format .gpx files created using a GPS system can also be imported using the Import GPS Data Assistant. See *Import GPS Data Assistant on page 1280*.

GPS data may include three types of points - Way, Track, and Route. Chief Architect Premier can only import a **.gpx** file if it includes one or more Way Points, and cannot use Route Points at all. If a **.gpx** file does not include any Way Points, it will not be imported, and if it includes any Route Points, they will be ignored.

Chief Architect supports the import of data in standard **.gpx** files that adhere to the GPX 1.1 Schema. Files that do not follow this standard cannot be imported.

## Import Terrain Assistant



The Import Terrain Assistant allows you to import elevation data saved in text (**.txt**) file format into a plan.

Each data point in this format has information about its X-axis (East to West location), Y-axis (North to South location), and Z-axis (elevation). It might also have a brief description. In order to import elevation data from a text file, you need to know how the data in the file is organized.

To launch the Import Terrain Assistant, select **File> Import> Terrain Data** . Click **Next**.

### SELECT FILE

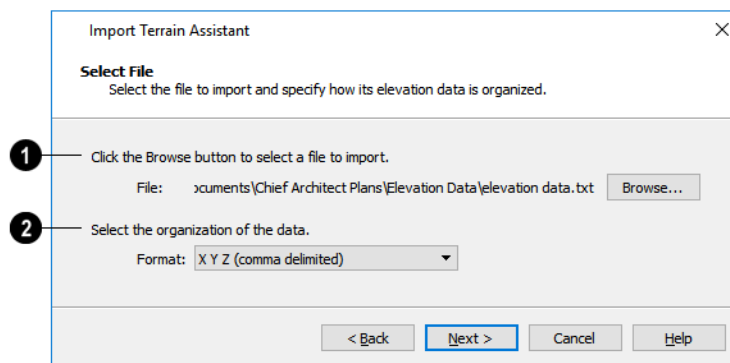

#### 1 Select a file to import

- Click the **Browse** button to locate a file on your computer. See *Importing Files on page 45*.
- If a file has been selected, its full pathname displays here for reference; if a file has not been selected, the directory of the last file imported displays. If the pathname is not that of a valid **.txt** file, this text will display in red.

#### 2 Select the organization of the data

- Elevation information can be organized in one of six different ways, and can be separated by either a comma (comma delimited) or a space (space delimited).
- **XYZ** - Information in this format begins with the X coordinate, followed by the Y coordinate and the Z coordinate.
- **#XYZ** - Information in this format begins with a number that belongs to each data point followed by the X coordinate, the Y coordinate, and the Z coordinate.
- **#XYZ Description** - Information in this format begins with a number that belongs to each data point followed by the X coordinate, the Y coordinate, the Z coordinate, and a description.
- **YXZ** - Information in this format begins with the Y coordinate followed by the X coordinate and the Z coordinate.

- **#YXZ** - Information in this format begins with a number that belongs to each data point followed by the Y coordinate, the X coordinate, and the Z coordinate.
- **#YXZ Description** - Information in this format begins with a number that belongs to each data point followed by the Y coordinate, the X coordinate, the Z coordinate, and a description.

Click **Next** to continue.

## FILTER DATA

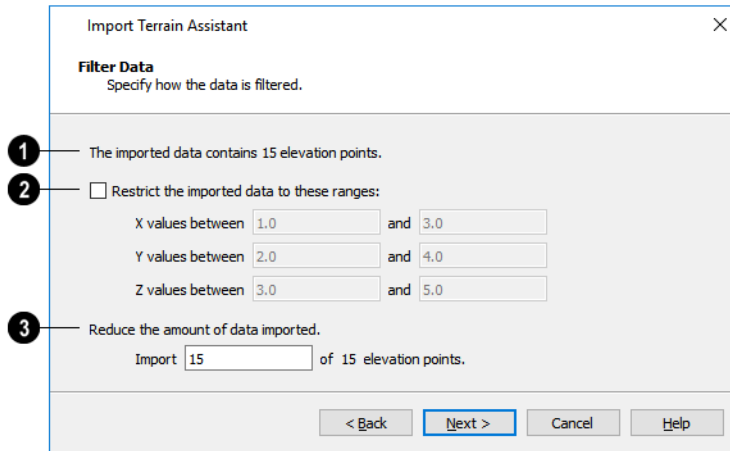

### 1 Imported Data

The number of elevation points that the text file contains displays here for reference.

Building terrain with a lot of elevation data can take a long time. If your text file has more than 1000 or 2000 elevation points, consider filtering it using the settings that follow.

You may also want to use the Linear Smoothing option in the Terrain Specification dialog. See [General Panel on page 1259](#).

### 2 Restrict the imported data to these ranges

One way to filter the data used is to define a range for each axis: **X**, **Y**, and **Z**. Data within these ranges is imported, while data outside these ranges is not.

In the following diagram, the outer rectangle and the points within it represent all of the data contained in a given text file. The smaller rectangle represents a subset of this data, defined by ranges on the X and Y axes.

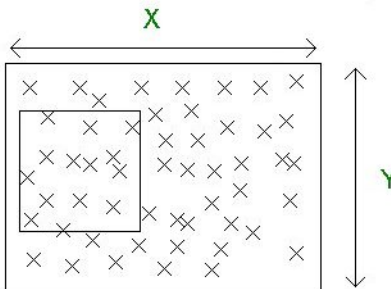

### 3 Reduce the amount of data imported

Another way to filter the imported data is by excluding elevation points.

Enter the total number of points to be imported. The points selected for import are found evenly distributed in the original file.

Click **Next** to continue.

## SCALE DATA

### 1 Imported Data

- The total number of data points to be imported and the ranges of their coordinates are described here.

### 2 Units

- Select the **Units** of measurement used for each axis.

### 3 Map

- **Map** a data point in the file to the origin in Chief Architect to position the terrain data relative to your plan. See [3D Drafting on page 13](#).

### 4 Scale

- To change the scale of the terrain, multiply the coordinates of each axis by a specific number to decrease or increase the relative size or relief of your terrain.

### 5 Rotate North Counterclockwise

- Specify an amount to rotate the terrain data counterclockwise, or to the left.

Click **Next** to finish.

# Import GPS Data Assistant



The Import GPS Data Assistant allows you to import terrain data from the standard **.gpx** file format. See *GPS Exchange Files on page 1276*.

Select **File> Import> GPS Data** to open the Import GPS Data Assistant, then click **Next** to continue.

 Due to the lack of accuracy in some GPS systems, exact distances using the Import GPS Data Assistant are not guaranteed.

## SELECT FILE

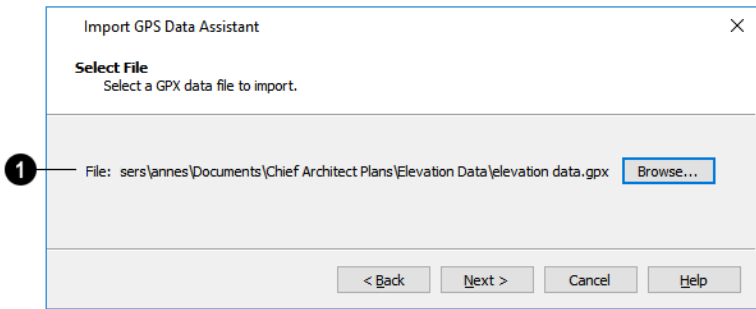

### 1 Select a file to import

- Click the **Browse** button to locate a **.gpx** file on your computer. See *Importing Files on page 45*.
- If a file has been selected, its full pathname is reported here for reference; if a file has not been selected, the directory of the last file imported displays. If the pathname is not that of a valid **.gpx** file, this text will display in red.

Note: Not all GPS programs use the standard **.gpx** file format; however, only files using the standard format can be imported.

Click **Next** to continue.

## IMPORT DATA AS

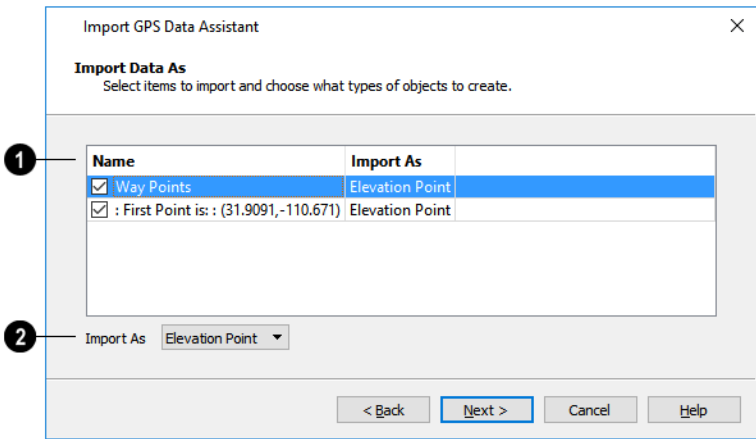



### 1 Name

Specify which items you want to import by checking the box to the left of the **Name**. Items with unchecked boxes are not imported.

### 2 Import As

Specify what you would like the selected item to **Import As** from the drop-down list.

- Only Way Points have elevation data associated with them. To import this data, import them as “Elevation Points”.
- Select “Marker” to import either Way Points or Track Points as location markers. Markers have no elevation data associated with them.
- Select “Polyline” to create an open CAD polyline based on the position of Way Points or Track Points. The points themselves are not imported. Polylines have no elevation data associated with them.
- Select “Terrain Perimeter” to create a closed Terrain Perimeter polyline based on the position of either Way Points or Track Points. The points themselves are not imported. A Terrain Perimeter has no elevation data associated with it. See [Terrain Perimeter on page 1244](#).



Way Points are typically imported as “Elevation Data”, while Track Points are imported as “Markers”, “Polylines”, or “Terrain Perimeter”.

Click **Next** to continue.

## TRANSFORM COORDINATES

### 1 Lower Elevation Data by

- Specify the amount that you would like to lower all imported elevation data.

### 2 Rotate North Counterclockwise

- Specify an amount to rotate the terrain data counterclockwise, or to the left.

### 3 Map this point to the origin

- Specify a point in the imported terrain data, defined by degrees **Latitude** and **Longitude**, that you would like to locate at the origin in the Chief Architect plan.

Click **Next** to finish.

If you do not see the imported terrain, select **Window> Fill Window** .

---

## Importing DWG/DXF Elevation Data



Select **File> Import> Drawing (DWG/DXF)** to open the Import Drawing Assistant, which you can use to import elevation data in **.dwg/.dxf** format. See *Import Drawing Assistant on page 1228*.

By default, the Import Drawing Assistant imports entities as regular CAD objects; however, you can specify that any layer in the drawing be converted to either a Terrain Perimeter or Elevation Data. If a layer is converted to Elevation Data, any points and lines on that layer are converted to Elevation Points and Lines, and any elevation data associated with them is preserved. Elevation data associated with objects in CAD blocks is not recognized, however.

- If an imported line has vertices with the same Z values, an Elevation Line is created.
- If the vertices have differing Z values, an Elevation Point is created for each vertex.
- Imported points are converted to Elevation Points.
- Other imported entities (solids, faces, etc.) are imported normally.



To avoid unexpected results when importing a drawing, only convert layers with elevation information to Elevation Data.

If a Terrain Perimeter does not exist in the plan or if a layer in the **.dwg/.dxf** file is not converted to a Terrain Perimeter, a Terrain Perimeter is created around the extents of the Elevation Data when it is imported.

---

## Converting CAD Objects to Terrain Data



CAD lines, splines, and polylines - either imported or drawn using Chief Architect Premier's CAD Tools - can be selected and converted to terrain data using the **Convert Polyline** edit tool.

In plan view, select a CAD line, spline, or polyline and click the **Convert Polyline**  edit button to open the Convert Polyline dialog. See *Convert Polyline on page 262*.

A Terrain Perimeter must exist before any other types of terrain object can be created. If no Terrain Perimeter is present in the current plan, this will be the only terrain item available in the Convert Polyline dialog.

When you click **OK**, the terrain object's specification dialog opens, allowing you to specify elevation data or other attributes.

# Roads, Driveways, and Sidewalks

## Chapter 38

Roads, sidewalks, driveways and parking lots are modeled in 3D like other terrain objects in Chief Architect. Because they have much in common with terrain objects and rely upon terrain data to be viewed in 3D, it is helpful to be familiar with terrain modeling before using these tools. See *Terrain on page 1243*.

### TOPICS

<b>Road and Sidewalk Defaults</b> .....	<b>1284</b>
<b>Road, Driveway, and Sidewalk Tools</b> .....	<b>1284</b>
<b>Displaying Road Objects</b> .....	<b>1287</b>
<b>Editing Road Objects</b> .....	<b>1288</b>
<b>Road Specification Dialog</b> .....	<b>1289</b>
<b>Road Marking Specification Dialog</b> .....	<b>1291</b>

---

## Road and Sidewalk Defaults



Default Settings can be accessed by selecting **Edit> Default Settings**. Click the + beside Roads, Sidewalks and Driveways to display the subheadings. See [Default Settings on page 77](#).

The settings in the Road Defaults, Driveway Defaults, Road Marking Defaults, and Sidewalk Defaults dialogs determine the initial settings when the road and sidewalk tools are used. It is a good idea to check these settings before placing any roads or sidewalks in your plan.

### ROAD DEFAULTS

You can access the Road Defaults dialog from the Default Settings dialog, or by double-clicking the **Road Tools**  button.

The settings in this dialog are the same as those in the Road Specification dialog. See [Road Specification Dialog on page 1289](#).

### DRIVEWAY DEFAULTS

You can access the Driveway Defaults dialog from the Default Settings dialog, or by double-clicking the **Driveway**  button.

The settings in this dialog are the same as those in the Terrain Path Specification dialog. See [Terrain Path Specification Dialog on page 1273](#).

### ROAD MARKING DEFAULTS

You can access the Road Marking Defaults dialog from the Default Settings dialog, or by double-clicking the **Road Marking**  button.

The settings in this dialog are the same as those in the Road Marking Specification dialog. See [Road Marking Specification Dialog on page 1291](#).

### SIDEWALK DEFAULTS

You can access the Sidewalk Defaults dialog from the Default Settings dialog, or by double-clicking the **Sidewalk**  button.

The settings in this dialog are the same as those in the Terrain Path Specification dialog, but only affect sidewalks and not other types of terrain paths. See [Terrain Path Specification Dialog on page 1273](#).

---

## Road, Driveway, and Sidewalk Tools



Roads objects can be drawn in plan view, camera views and overviews, but only when a Terrain Perimeter exists in the plan. See [Terrain Perimeter on page 1244](#).

When road objects are first placed into your plan, their initial dimensions and properties are controlled by their default settings. See [Road and Sidewalk Defaults on page 1284](#).

Straight and Spline road objects:

- Are typical line- and spline-based objects, and can be edited as such.
- Are flat along their widths, which makes it easy to create roads on sloping terrain.
- Can be joined end-to-end to form intersections and networks.
- Have a consistent width that can be defined in their specification dialogs. See [Road Specification Dialog on page 1289](#) and [Terrain Path Specification Dialog on page 1273](#).

Polyline road objects, on the other hand, are actually Terrain Features which follow the contours of the terrain rather than cut into them. They are drawn as rectangles but can be edited to any shape. See [Terrain Features on page 1252](#) and [Editing Closed Polyline-Based Objects on page 228](#).

Roads have curbs, and Sidewalks and Driveways cut out curbs and gutters wherever they meet a Road or a Road Polyline.



The **Convert Polyline**  edit tool can be used to convert a CAD polyline into a number of types of road object. See [Convert Polyline on page 262](#).

Once road objects have been placed, they can be edited individually or as a group. See [Editing Road Objects on page 1288](#).

## ROAD TOOLS



Select **Terrain> Road> Straight Road**, then click and drag to draw a line within the Terrain Perimeter to draw a Straight Road.

The ends of multiple road sections can be connected together. Roads are edited along their center line and can be edited much like other line-based objects. See [Editing Line-Based Objects on page 216](#).



Select **Terrain> Road> Spline Road**, then click and drag to draw a curved road composed of spline segments.

Spline roads are drawn and edited like other spline-based objects. See [Editing Spline-Based Objects on page 235](#).



Select **Terrain> Road> Polyline Road**, then click and drag to draw a rectangular polyline which can then be edited to any shape.



Select **Terrain> Road> Median**, then click and drag within a road to draw a rectangular polyline that cuts a hole in a road, revealing the terrain material beneath. If the road has a curb, the Median receives one as well.



 A **Cul-de-sac** is a road object with a special, rounded shape that can be placed at the end of a Road object. Select **Terrain> Road> Cul-de-sac** and click on the end of a road to place a cul-de-sac at that location. Culs-de-sac cannot be connected to the edge of Road Polylines.



Select **Terrain> Road> Road Marking**, then click and drag within a road to draw a rectangular region with a different material than the road surface.



Select **Terrain> Road> Road Stripe**, then click and drag within a road to draw a stripe of road marking material on the road surface. Multiple road stripes can be connected together.

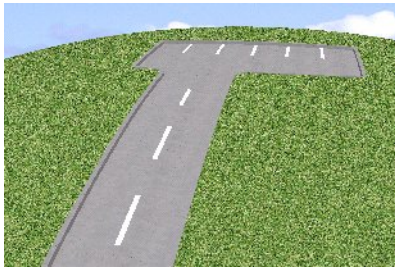

## DRIVEWAY TOOLS



Select **Terrain> Driveway> Straight Driveway**, then click and drag a line within the Terrain Perimeter. Multiple driveway sections can be connected together.

Driveways are edited like other line-based objects. See [Editing Line-Based Objects on page 216](#).



Use the **Spline Driveway** tool to create a curved driveway. Select **Terrain> Driveway> Spline Driveway**. Spline driveways are drawn and edited like CAD splines. See [Splines on page 324](#).



Select **Terrain> Driveway> Driveway Polyline**, then click and drag within the Terrain Perimeter to draw a rectangular polyline which can then be edited to any shape.

Driveway polylines are edited just like CAD polylines. See [Editing Closed Polyline-Based Objects on page 228](#).

## SIDEWALK TOOLS



To create a sidewalk with no curves, select **Terrain> Sidewalk> Straight Sidewalk**, then click and drag a line within the Terrain Perimeter.

Sidewalks are edited along their center line like line-based objects. See [Editing Line-Based Objects on page 216](#).



Select **Terrain> Sidewalk> Spline Sidewalk**, then click and drag to draw a curved sidewalk composed of spline segments.



Select **Terrain> Sidewalk> Sidewalk Polyline**, then click and drag within the Terrain Perimeter to draw a rectangular polyline which can then be edited to any shape.



Select a Road or Median and click the **Auto Generate Sidewalk** edit button to open the Auto Generate Sidewalks dialog.

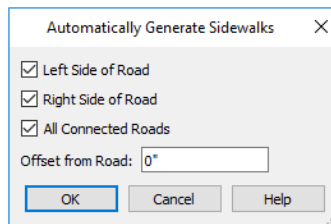

- **Left/Right Side of Road** - Check one or both boxes to generate a sidewalk on the selected road object.
- Check **All Connected Roads** to generate a sidewalk along all other roads connected to the selected road object.
- **Offset From Road** - Specify a gap between the generated sidewalk and the selected road object.

---

## Displaying Road Objects



Roads and sidewalks display in floor plan and 3D views based on the settings for their layers in the Layer Display Options dialog. See [Layers on page 176](#).

### IN 3D VIEWS

In order for Road objects to be visible in 3D views, they must be drawn within the Terrain Perimeter. Any portions of these objects drawn outside the Terrain Perimeter will not be seen in 3D views.

By default, the terrain rebuilds automatically when road objects are added, removed or edited. If it does not, you can select **Terrain> Build Terrain** . See [Terrain Perimeter on page 1244](#).

### IN SCHEDULES

Like a variety of other objects, Road objects can be included in schedules. See [The Schedule Tools on page 682](#).

By default, Driveways, Medians, Roads, and Road Markings are listed in schedule categories of the same names while Sidewalks are listed in the "Terrain Paths" category. You can, however, assign a selected object to the category of your choice in its specification dialog. See [Schedule Panel on page 704](#).















## Editing Road Objects

Road objects can be selected in 2D and 3D views and edited using the edit handles, the Edit Toolbar, and their specification dialogs.

**Terrain Walls**  and **Terrain Curbs** are also Road objects. See *Terrain Wall and Curb Tools on page 1254*.

### USING THE EDIT HANDLES

The edit handles available for a selected road object depend on the type of object selected.

- **Straight Roads** , straight **Driveways** , straight **Road Stripes** , straight **Terrain Walls** , and straight **Terrain Curbs**  are edited along their centerline like a line or open polyline. See *Editing Line-Based Objects on page 216*.
- **Spline Roads** , **Spline Sidewalks**, **Spline Terrain Walls**  are edited along their centerline like CAD splines. See *Editing Spline-Based Objects on page 235*.
- **Polyline Roads** , **Culs-de-sac** , **Medians** , **Road Markings** , **Polyline Driveways**  and **Polyline Sidewalks**  are edited along their perimeter, like standard polylines. The width is determined by the polyline's shape. See *Editing Closed Polyline-Based Objects on page 228*.
- **Medians**  are also edited like polylines.
- In plan and cross section/elevation views, Road object labels also have a small square Move edit handle and small rectangular Rotate handle.

### IN THE SPECIFICATION DIALOG

 Road objects can be customized in their specification dialogs. See *Road Specification Dialog on page 1289*, *Terrain Feature Specification Dialogs on page 1268*, and *Terrain Path Specification Dialog on page 1273*.

### USING THE EDIT TOOLS

A selected road object can be edited in a variety of ways using the buttons on the Edit Toolbar. See *The Edit Toolbar on page 130*.

### CONVERT TO POLYLINE OBJECT

 A selected Straight or Spline Road, Sidewalk or Driveway can be converted into a Polyline Road, Sidewalk or Driveway by clicking the **Convert to Polyline Object** edit button.

Polyline Roads, Sidewalks and Driveways display the same edit handles as closed polylines, allowing you to edit their shapes as much as needed.

### ADDING ROAD OBJECTS TO THE LIBRARY

You can create your own road objects and save them to the library. Select any combination of elevation points, elevation lines, terrain features, roads, sidewalks, road markings, or even the terrain perimeter itself and send them to the library as one unit.



When a group of terrain objects from the library is placed into a plan, each object becomes independent and can be edited individually. See [Adding Library Content on page 965](#).

## Road Specification Dialog

To open the Road Specification dialog, select a Straight Road, Spline Road, Polyline Road, Median, or Cul-de-sac and click the **Open Object** edit button.

The settings in this dialog are also found in the Road Defaults dialog. See [Road and Sidewalk Defaults on page 1284](#).

Many of the settings in this dialog are similar to those in the Terrain Path Specification dialog. See [Terrain Path Specification Dialog on page 1273](#).

### GENERAL PANEL

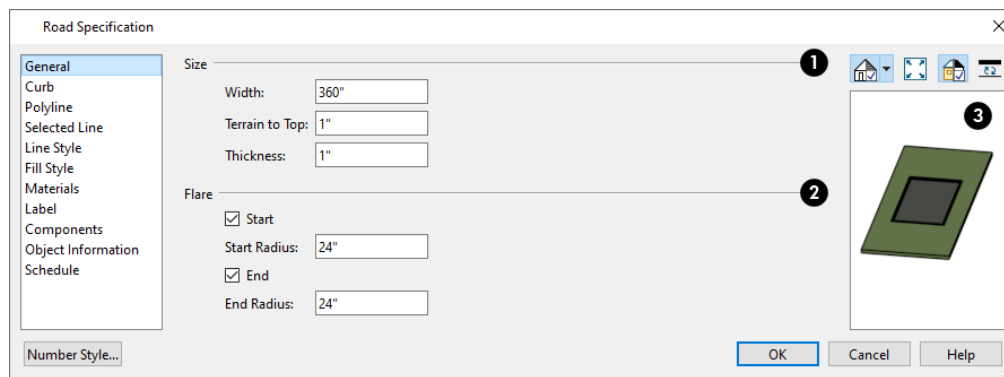

#### 1 Size

- Specify the road's **Width**. Not available for culs-de-sac and non-centerline roads.
- Specify the **Terrain to Top** value, which is the distance from the top surface of the terrain to that of the road. If this value is a negative number, the road sinks into the terrain.
- Specify the road's **Thickness**.

#### 2 Flare

When one road intersects another, flares can be specified.

- Check **Start** to create a flare at the starting end of the selected road, then specify the **Radius** of that flare.
- Check **End** to create a flare at the end of the selected road, then specify the **Radius** of that flare.

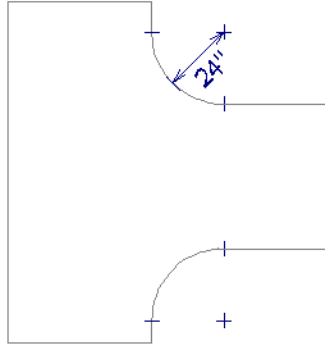

Flaring is not available for culs-de-sac, medians, or non-centerline roads.

### 3 Preview

A preview of the selected road displays on the right side of the panel. See *Dialog Preview Panes on page 22*.

## CURB PANEL

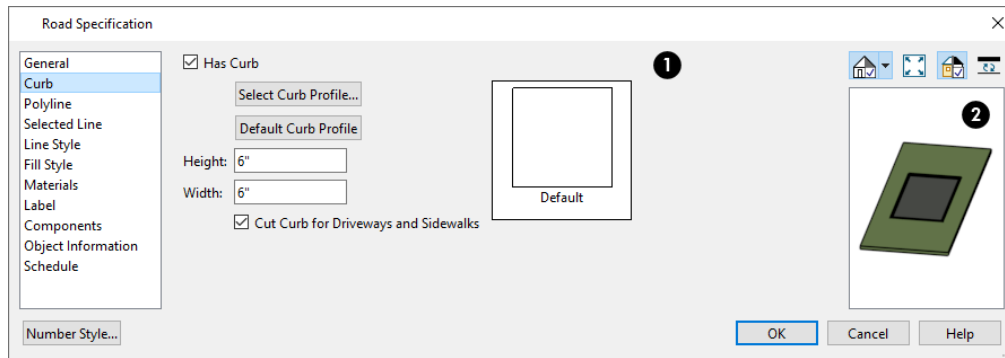

### 1 Curb

- Check **Has Curb** if you want the selected road to include a curb.
- Click **Select Curb Profile** to apply a different curb profile to the selected road.
- Click **Default Curb Profile** to use the profile set in the Road Defaults dialog. In the Road Defaults dialog, clicking this button will reset the straight-sided system default curb profile.
- Enter **Height** and **Width** values for the curb.
- Check **Cut Curb for Driveways and Sidewalks** to cut the curb for driveways and sidewalks.
- A preview of the selected profile displays to the right of the settings.

### 2 Preview

A preview of the selected cabinet displays on the right side of the panel. See *Dialog Preview Panes on page 22*.

## POLYLINE PANEL

The POLYLINE panel states the length of the road's **Perimeter**, its **Area** and its **Volume**. Not available in the Road Defaults dialog. For more information, see *Polyline Panel on page 317*.

### SELECTED LINE/ARC PANEL

The SELECTED LINE panel is available when a Straight Road is selected. For more information, see [Line Panel on page 304](#).

The SELECTED ARC panel is available when the curved segment of a Straight Road is selected. See [Arc Panel on page 312](#).

See, too, [Selected Edge on page 212](#) and [Change Line/Arc on page 256](#).

### SPLINE PANEL

The SPLINE panel is available when a Spline Road is selected. Specify the angle between the line segments used to draw the spline. For more information, see [Spline Panel on page 318](#).

### LINE STYLE PANEL

This panel is the same as the LINE STYLE panel in many other specification dialogs. See [Line Style Panel on page 305](#).

### FILL STYLE PANEL

The settings on the FILL STYLE panel affect the appearance of the selected object in plan view. For information about these settings, see [Fill Style Panel and Dialogs on page 193](#).

### MATERIALS PANEL

The settings on the MATERIALS panel affect the appearance of the selected object in 3D views. For information about these settings, see [Materials Panel on page 1055](#).

The Curb material is not calculated in the Materials List. See [Materials Lists on page 1303](#).

### LABEL PANEL

Road labels displays in floor plan and cross section/elevation views when the “Terrain Labels” layer is turned on and use the Text Style assigned to that layer. See [Terrain and Road Labels on page 1257](#).

For more information, see [Label Panel on page 700](#).

### COMPONENTS PANEL

The information on the COMPONENTS panel can be used in the materials list. For more information, see [Components Panel on page 1330](#).

---

## Road Marking Specification Dialog



Select a Road Marking or Road Stripe and click the **Open Object** edit button to open the Road Marking Specification dialog.

The settings in this dialog are also found in the Road Marking Defaults dialog.

### GENERAL PANEL

The GENERAL panel is only available for **Road Stripes** . See [Road Tools on page 1285](#).

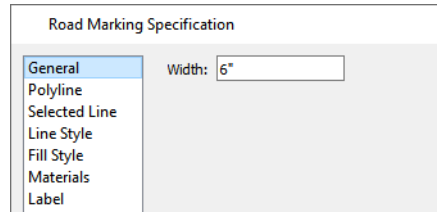

Enter a **Width** value for the selected Road Stripe.

### **POLYLINE PANEL**

The POLYLINE panel states the length of the road marking’s **Perimeter**, its **Area**, and its **Volume**. Not available in the Road Marking Defaults dialog. For more information, see *Polyline Panel on page 317*.

### **SELECTED LINE/ARC PANEL**

The SELECTED LINE panel is available when the straight segment of a road marking is selected. See *Line Panel on page 304*.

The SELECTED ARC panel is available when the curved segment of a road marking is selected. See *Arc Panel on page 312*.

See, too, *Selected Edge on page 212* and *Change Line/Arc on page 256*.

### **LINE STYLE PANEL**

This panel is the same as the LINE STYLE panel in many other specification dialogs and affects the appearance of the selected object in plan view. See *Line Style Panel on page 305*.

### **FILL STYLE PANEL**

The settings on the FILL STYLE panel affect the appearance of the selected object in plan view. For information about these settings, see *Fill Style Panel and Dialogs on page 193*.

### **MATERIALS PANEL**

The settings on the MATERIALS panel affect the appearance of the selected object in 3D views. For information about these settings, see *Materials Panel on page 1055*.

The material selected here is not calculated in the Materials List. See *Materials Lists on page 1303*.

### **LABEL PANEL**

Road Marking labels displays in plan view when the “Terrain Labels” layer is turned on and use the Text Style assigned to that layer. See *Terrain and Road Labels on page 1257*.

For more information, see *Label Panel on page 700*.

# Plants and Sprinklers

## Chapter 39

The Plant Tools and sprinklers from the Library Browser allow you to create planting designs and irrigation systems in your terrain.

The Terrain Tools are discussed in their own chapter. See *Terrain on page 1243*.

### TOPICS

<b>Plant Tools</b> .....	<b>1294</b>
<b>Plant Chooser Dialog</b> .....	<b>1295</b>
<b>Hardiness Zones</b> .....	<b>1297</b>
<b>Plant Image Specification Dialog</b> .....	<b>1297</b>
<b>Plant Specification Dialog</b> .....	<b>1301</b>
<b>Sprinkler Tools</b> .....	<b>1301</b>
<b>Sprinkler Specification Dialogs</b> .....	<b>1302</b>

## Plant Tools



Select **Terrain> Plant** to add plants to your landscaping plan. Plants can also be placed in a plan directly from the library. See [Placing Library Objects on page 972](#).

Plant objects are actually images, which provide realism while avoiding high 3D surface count. Once created, plant images can be selected and edited much like other image objects. See [Editing Images on page 1187](#).



Select **Terrain> Plant> Plant Chooser** to open the Plant Chooser dialog and find plants based on their characteristics and requirements. See [Plant Chooser Dialog on page 1295](#).



Select **Terrain> Plant> Create Plant Image** to create a plant image. See [Plant Image Specification Dialog on page 1297](#). Once a plant image is created, it can be added to the library for future use. See [Creating Images on page 1185](#).



Select **Terrain> Plant> Grow All Plants** to open the Grow Plants dialog.

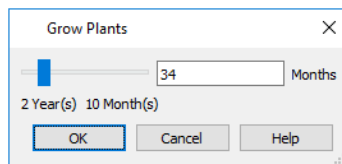

Click and drag the slider bar and select a growth period from zero to twenty years. This only works for plants that have a mature height and mature age specified in the Plant Image Specification dialog. See [Plant Information Panel on page 1299](#).



Select **Terrain> Plant> Show Hardiness Zones** to access regional climate zone maps. See [Hardiness Zones on page 1297](#).

Chief Architect's Library Browser features a Plants category with a selection of plant, shrub and tree images which you can place in your plan. See [The Library on page 945](#).

Once placed in your plan, these plant images can be selected, moved, copied and resized to produce a wide variety of unique landscaping designs. See [Editing Images on page 1187](#).

### GARDEN BEDS



Garden Beds are a special type of **Terrain Feature** with material and height attributes typical of planting beds. In addition, you can choose to distribute copies of a plant image within a Garden Bed. See [Terrain Feature Types on page 1253](#).

### PLANTS LIBRARY CATALOGS



In the Library Browser, browse to Chief Architect Core Catalogs> Plants to access a selection of plant images and symbols. Select the library object you want, then click in any view to place it in the plan. See [The Library on page 945](#).

A selection of Bonus Catalogs of plants is also available for download. See [Chief Architect Bonus Catalogs on page 961](#).

In addition, you can add single plants and blocked groups of plants to the library. See [Adding Library Content on page 965](#) and [Architectural Blocks on page 1007](#).

## PLANT SCHEDULES



The **Plant Schedule** tool allows you to create customizable plant schedules and plant labels that display schedule numbers. See *The Schedule Tools on page 682*.

# Plant Chooser Dialog



Select **Terrain > Plant > Plant Chooser** or click the **Plant Chooser** button at the bottom of the Library Browser window to open the Plant Chooser.

Use this dialog to search the library for plant images and symbols that match your search parameters. You can search using any or all of the options in the Plant Chooser.

The search parameters in this dialog correspond to the settings on the PLANT INFORMATION panel of the Plant Image Specification dialog. See *Plant Information Panel on page 1299*.

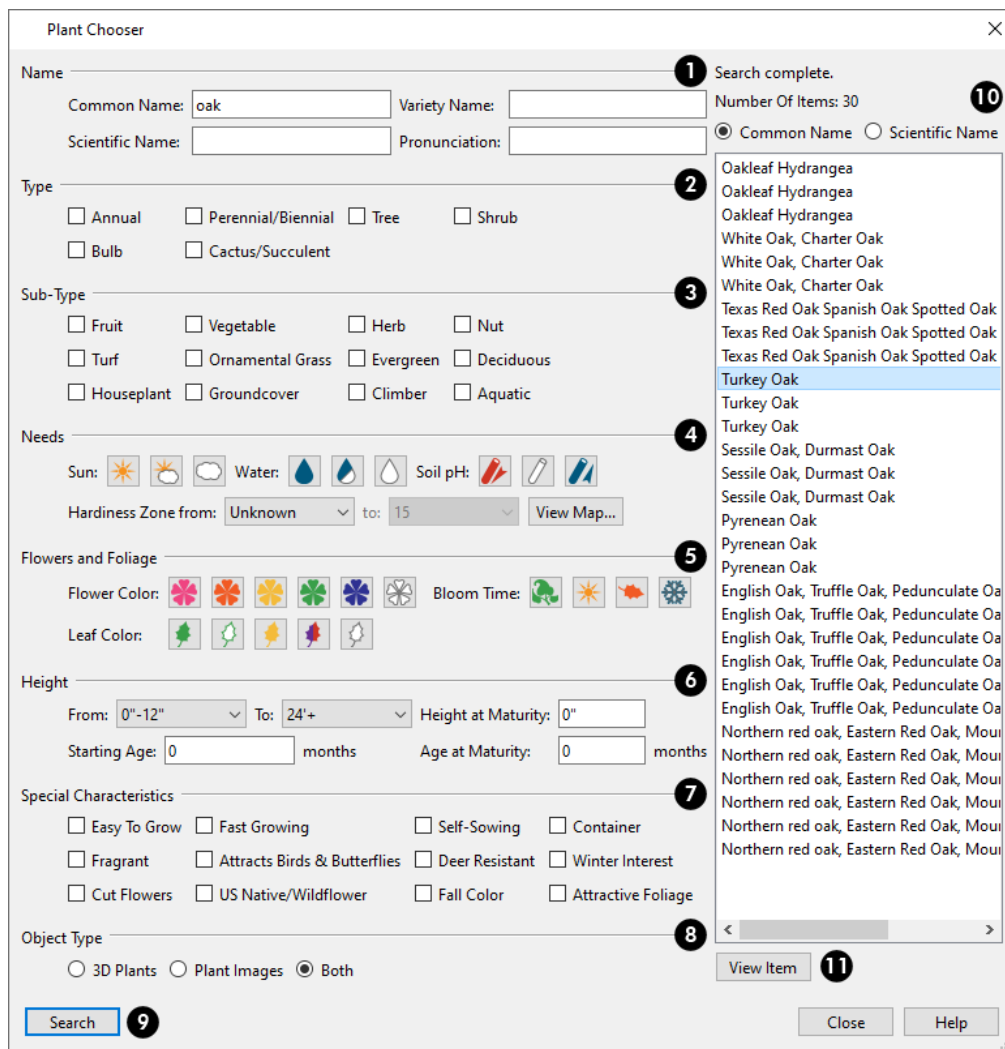

### 1 Name

Type the **Name** of a plant that you would like to find.

- Specify the plant's **Common Name**, **Scientific Name**, or its **Variety Name**.
- A **Pronunciation** field is also provided. In the Plant Image Specification dialog, it is populated with a phonetic pronunciation guide for the plant's scientific name.

## 2 Type

Check one or more boxes to indicate selected plant **Type** to search for.

## 3 Sub-Type

Check one or more boxes to specify the selected **Sub-Type** to search for.

## 4 Needs

Specify the plant **Needs** to search for. These include the **Sun**, **Water**, **Soil pH**, and **Hardiness Zone** range. See *Hardiness Zones on page 1297*.

## 5 Flowers and Foliage

-

- Specify the **Flower Color** to search for. Multiple colors can be selected.
- Specify the **Leaf Color** to search for. Multiple colors can be selected.
- Specify the **Bloom Time** to search for, which is the season when the plant produces flowers.

## 6 Height

Specify the plant **Height** at maturity to search for. This is used with the Grow Plants feature. See *Plant Tools on page 1294*.

- An average mature height range can be entered using the **From** and **To** drop-down lists.
- A specific **Height at Maturity** to search for can be entered in the text field.
- A specific **Starting Age**, in months, can be entered in the text field.
- A specific **Age at Maturity**, in months, can be entered in the text field.

## 7 Special Characteristics

Check one or more boxes to search for plants with **Special Characteristics**.

## 8 Object Type

Select which types of plant **Object Type** to search for. 3D Plants are symbol objects, while Plant Images are two dimensional images.

## 9 Search

Click the **Search** button at the bottom of the dialog to search for plants that meet your search criteria. The search results display to the right.

## 10 Search Results

Your search results display here.



- Information about the search status as well as the **Number of Items** that match your search criteria are stated.
- Specify whether you want the search results to use the **Common Name** or **Scientific Name**.
- Click on the name of a plant in the list to see its location in the Library Browser.

## 11 View Item

Click the **View Item** button to see more information about the selected plant in the Plant Information dialog. See [Plant Image Specification Dialog on page 1297](#).

---

## Hardiness Zones



Select **Terrain> Plant> Show Hardiness Zones** to view a selection of regional Hardiness Zone Maps. Click the drop-down list at the top left to select various regions.

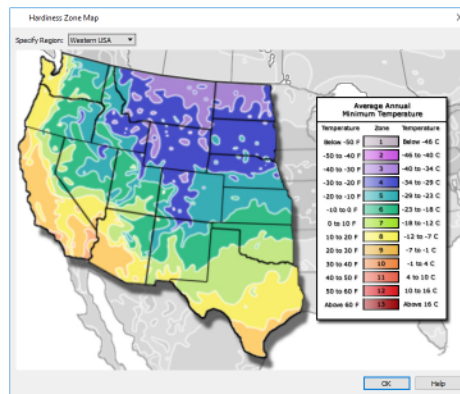

---

## Plant Image Specification Dialog



Select one or more plant images in a plan view or 3D view and click the **Open Object** edit button to open the Plant Image Specification dialog.

This dialog can also be accessed by selecting **Terrain> Plant> Create Plant Image**  or by selecting **New> Plant Image** from the Library Browser contextual menu.

The **PLANT INFORMATION** and **PLANT DESCRIPTION** panels are also found in the Plant Information dialog, which can be accessed from the Plant Chooser dialog. See [Plant Chooser Dialog on page 1295](#).

## IMAGE PANEL

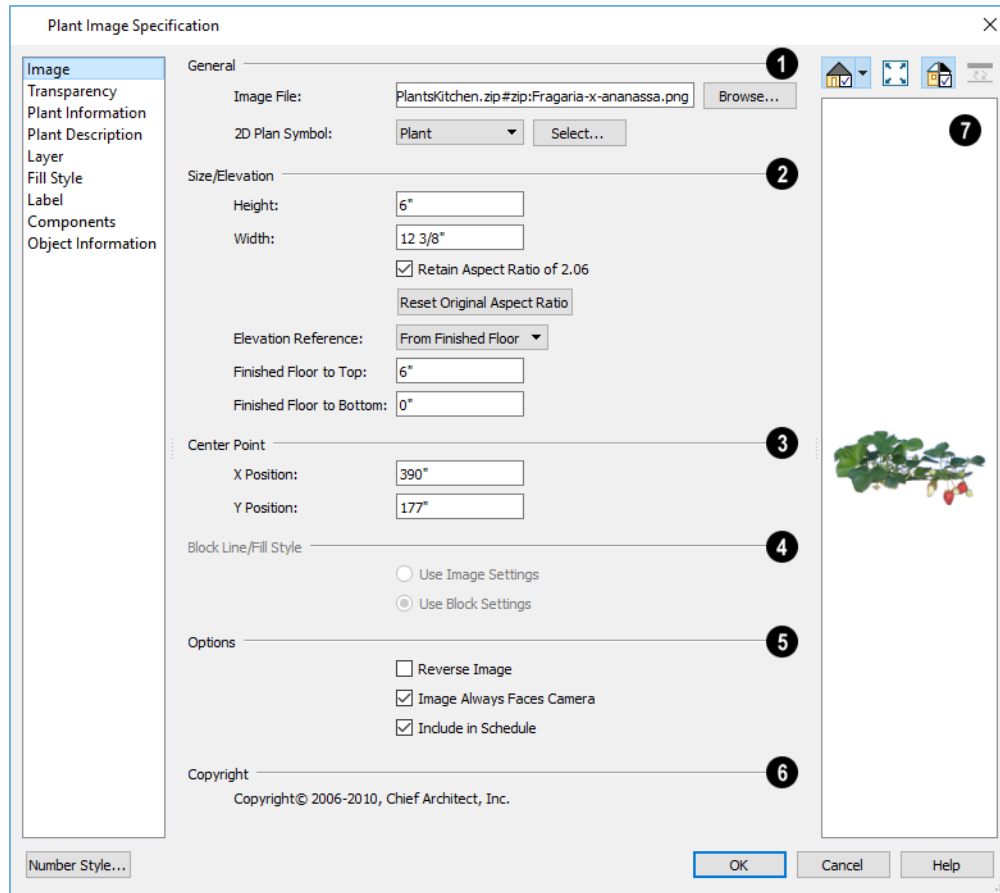

### 1 General

- The path and name of the selected plant's **Image File** displays here.
- Click **Browse** to specify the saved location on your computer of the image that represents the plant in 3D views.
- A number of **2D Plant Symbols** are available to represent the image in plan view. Choose one from the drop-down list or click the **Select** button to choose a CAD block from the Library Browser or a list of CAD blocks in the current plan. See *Select Library Object Dialog on page 974* and *CAD Block Management on page 333*.

### 2 Size/Elevation

Specify the **Size/Elevation** of the plant image, as seen in 3D views.

- Specify the **Height** and **Width** of the image.
- When **Retain Aspect Ratio of** is checked, if you change either the Height or Width, the other value changes to maintain this ratio. If this is unchecked and you resize the plant image, it may become distorted.
- Click **Reset Original Aspect Ratio of** to reset the image's original aspect ratio and remove any distortion caused by resizing.

- Select the **Elevation Reference** from the drop-down list. This determines where the next two settings are measured from and also affects their setting labels.
- Specify the **to Top** distance, measured from the Elevation Reference to the top edge of the image.
- Specify the **to Bottom** distance, measured from the Elevation Reference to the bottom edge of the image.

### 3 Center Point

Specify the location of the selected plant image's **Center Point**.

- Position the selected plant image in reference to the plan coordinates by specifying its **X Coordinate** and **Y Coordinate**.

### 4 Block Line/Fill Style

Specify the **Block Line/Fill Style** of the selected plant image's 2D symbol in plan view. Only available when a CAD block from the library is selected as the image's 2D Plan Symbol.

- Select **Use Image Settings** to use the image's line style, which is set by layer, and its fill style, which is "No Pattern".
- Select **Use Block Settings** to use the 2D CAD block's line and fill styles. See *Custom 2D Symbols on page 332*.

### 5 Options

- Check **Reverse Image** to reflect the appearance of the image about an imaginary vertical line through its center.
- Check **Image Always Faces Camera** to prevent the plant image from rotating with the camera.
- Check **Include in Schedule** to include the selected plant in the Plant Schedule. See *Schedules and Object Labels on page 681*.

### 6 Copyright

If the selected plant image has been copyrighted, its **Copyright Information** displays here.

### 7 Preview

A preview of the selected plant image displays here. The Glass House Rendering Technique is not available for plant images. See *Dialog Preview Panes on page 22*.

## TRANSPARENCY PANEL

The settings on the Transparency panel of this dialog are similar to those on the same panel of the Image Specification dialog. For more information, see *Transparency Panel on page 1190*.

## PLANT INFORMATION PANEL

The settings on the Plant Information panel correspond to the search parameters in the Plant Chooser. See *Plant Chooser Dialog on page 1295*.

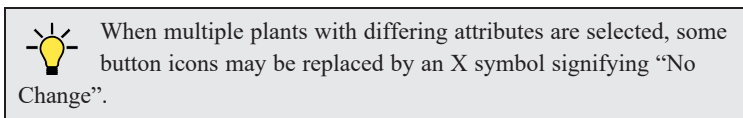

## PLANT DESCRIPTION PANEL

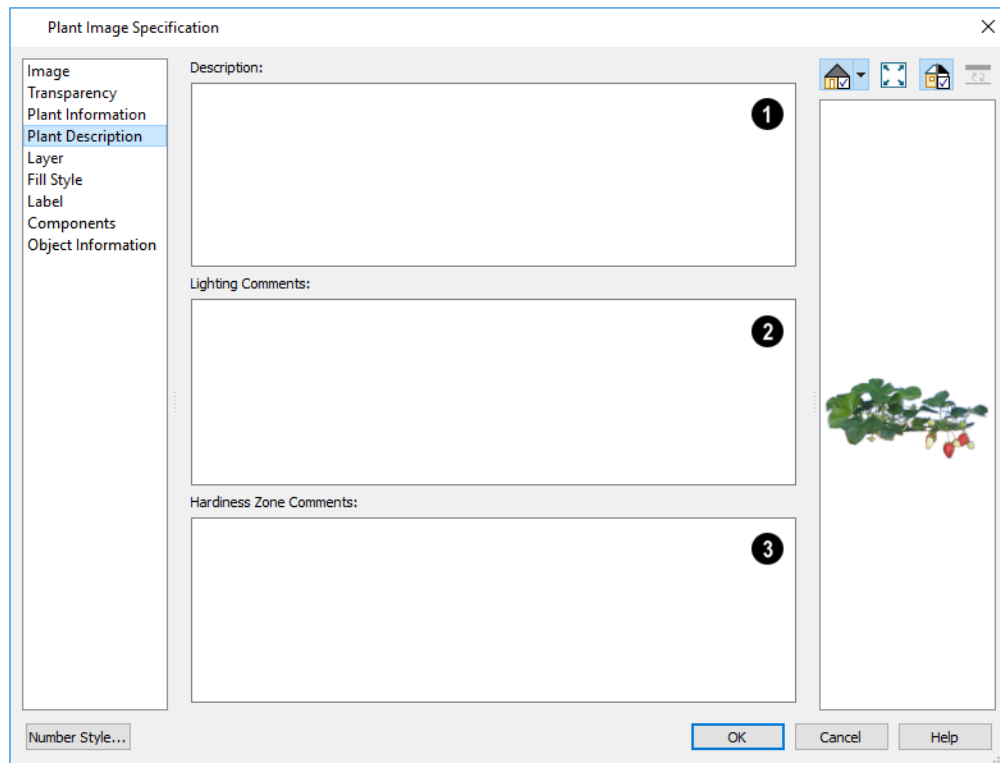

### 1 Description

A detailed **Description** of the plant displays in this text field.

### 2 Lighting Comments

Information in the **Lighting Comments** fields describes the plant's light requirements.

### 3 Hardiness Zone Comments

**Hardiness Zone Comments** are given here. See *Hardiness Zones on page 1297*.

## LAYER PANEL

For information about the Layer panel, see *Layer Panel on page 186*.

## FILL STYLE PANEL

The settings on the FILL STYLE panel control the appearance of the selected plant's 2D Plant Symbol in plan view. By default, plant images' fill style is None (Transparent). For information about the settings on this panel, see *Fill Style Panel and Dialogs on page 193*.

If the plant's 2D Plan Symbol does not form a closed shape or is a CAD block is selected from the library, the settings on the Fill Style panel will have no effect on the appearance of the plant in plan view. If you wish, you can create a custom CAD block with the desired fill pattern. See *CAD Blocks on page 329*.

## LABEL PANEL

Plant labels display in plan view when the “Plants, Labels” layer is turned on and use the Text Style assigned to that layer. See *Label Panel on page 700*.

## COMPONENTS PANEL

The information on the COMPONENTS panel can be used in the materials list. For more information, see *Components Panel on page 1330*.

## OBJECT INFORMATION PANEL

The information entered on the OBJECT INFORMATION panel can be used in schedules and the materials list. For more information, see *Object Information Panel on page 1331*.

## SCHEDULE PANEL

The settings on the SCHEDULE panel determine which schedule categories the selected object is included in. See *Schedule Panel on page 704*.

---

# Plant Specification Dialog

 Select a 3D plant symbol and click the **Open Object** edit button to open the Plant Specification dialog. This dialog is the same as that for a variety of symbol objects in the program. See *Symbol Object Specification Dialogs on page 986*.

3D plants also have a Symbol Specification dialog, which can be accessed by clicking the **Open Symbol**  edit button. See *Symbol Object Specification Dialogs on page 986*.

---

# Sprinkler Tools



Use the **Sprinkler Tools** to design a sprinkler system in your plan.



Select **Terrain > Sprinkler > Sprinkler Head** to open the Select Library Object dialog. Browse to a sprinkler type in the library, click OK, then click in the drawing area to place as many as you need. Once drawn, sprinkler heads can be selected and edited. See *Sprinkler Specification Dialogs on page 1302*.



Select **Terrain > Sprinkler > Sprinkler Line** to draw sprinkler lines in your plan. Sprinkler lines are 2D objects and are drawn and edited much like CAD Lines. See *Line Tools on page 300*.

## DISPLAYING SPRINKLERS

The display of Sprinkler Heads, Lines and Splines can be controlled in the Layer Display Options dialog. See *Layer Attributes on page 177*.

In plan view, Sprinkler Head symbols indicate the spray angle.

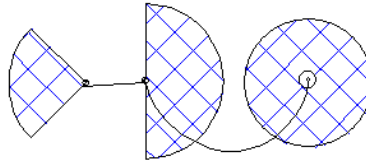

Sprinkler head display in 3D views; however, Sprinkler Lines and Splines do not.

Sprinkler Heads are counted in the Materials List, as is the total length of Sprinkler Lines and Splines. See [Materials Lists on page 1303](#).



Sprinkler heads can be included in schedules. See [The Schedule Tools on page 682](#).

## EDITING SPRINKLERS

Sprinklers can be edited much the way other objects from the library can: using their edit handles, edit tools, and in their specification dialog. See [Editing Library Objects on page 970](#).

---

## Sprinkler Specification Dialogs

 To open the Sprinkler Specification dialog, select a sprinkler or group of sprinklers and click the **Open Object** edit button. You can also double-click the sprinkler(s) using the **Select Objects**  tool.

The Sprinkler Specification dialog an example of a Symbol Object Specification dialog. See [Symbol Object Specification Dialogs on page 986](#).

Sprinkler Lines and Sprinkler Splines also have a specification dialog which is very similar to the Polyline Specification dialog. See [Polyline Specification Dialog on page 317](#).

# Materials Lists

## Chapter 40

Chief Architect can calculate a Materials List in three ways: **for All Floors, From Area, or for Room**. In addition, a polyline or multiple polylines can be used to define areas in a plan a Materials List can be generated from.

Materials Lists can be created, edited, and printed directly from the program. They can also be exported as text, **.xml**, or **.html** files for use in other programs.

 The Materials List's calculations are based on assumptions that may not match your building style. Chief Architect Software makes no representation as to the accuracy or reliability of the Materials List generated by Chief Architect Premier. Always compare the Materials List with a manual take-off before providing a quote or ordering materials for a job.

### TOPICS

<b>The Materials List Tools</b> .....	<b>1304</b>
<b>Creating an Accurate Materials List</b> .....	<b>1305</b>
<b>Structural Member Reporting</b> .....	<b>1306</b>
<b>Organizing Materials Lists</b> .....	<b>1310</b>
<b>Materials List Specification Dialog</b> .....	<b>1312</b>
<b>Materials List Columns</b> .....	<b>1317</b>
<b>Editing Materials Lists</b> .....	<b>1319</b>
<b>Materials List Formulas</b> .....	<b>1320</b>
<b>Materials List Polylines</b> .....	<b>1322</b>
<b>Materials List Polyline Specification Dialog</b> .....	<b>1322</b>
<b>Saving and Managing Materials Lists</b> .....	<b>1324</b>
<b>Printing and Exporting the Materials List</b> .....	<b>1325</b>
<b>The Master List</b> .....	<b>1327</b>
<b>Object Components</b> .....	<b>1329</b>
<b>Object Information Panel</b> .....	<b>1331</b>

## The Materials List Tools



A Materials List is essentially a view of the current model, presented as a spreadsheet instead of a drawing or rendering. Any changes made to the model update all Live Materials Lists and vice versa: if you add Price or other information to an object in a Materials List, the object or objects in the model automatically inherit that attribute. Select **Tools> Materials List** to access the Materials List tools.

When you close a Materials List window, the program will ask if you want to save the Materials List. Type a name and click **Yes** to save the list or click **No** to close the list without saving it. See *Saving and Managing Materials Lists on page 1324*.

### CALCULATE FROM ALL FLOORS



Select **Tools> Materials List> Calculate Materials for All Floors** to generate a Materials List for the entire model.

Materials lists calculated for all floors can be lengthy, and only a portion of the list may display on your screen at one time. Use the scrollbars to scroll through the complete list. Move the pointer to cells in the list and click to make changes. Once created, you can also specify which categories are included in the Materials List Specification dialog. See *Categories Panel on page 1313*.

### CALCULATE MATERIALS FROM SELECTION

Select one or more objects and click the **Calculate Materials From Selection** edit button to create a Materials List that calculates only the selected object(s) and their components.

When the selected object is a room, its moldings and wall, floor, and ceiling finish materials are counted, as is its subflooring; but doors, windows, and structural materials like framing and other structural materials are not.

### CALCULATE MATERIALS IN ROOM



To create the Materials List for a room, select the room and then select **Tools> Materials List> Calculate Materials for Room**.

**Calculate Materials in Room**  is also available on a selected room's edit toolbar. See *Editing Rooms on page 419*.

A Materials List calculated from a room is created for only the contents of that room: wall materials are not included. An object will be counted in the Materials List if its center point is located inside the room.

All objects associated with a Distribution Path or Region will be listed in a schedule if the center point of the path or region is located inside the room. If the center point of the path or region is not located in the room, none of its objects will be listed. See *Distributed Objects on page 1042*.

### MATERIALS LIST POLYLINE



You can also produce a Materials list for a defined area of a plan in plan view using a **Materials List Polyline**.

Materials List Polylines are advantageous because they can be edited to any shape, saved, and used as many times as needed. There are also several ways to create them. See *Materials List Polylines on page 1322*.



## CALCULATE STRUCTURAL MATERIALS FOR DECK

 The structural materials for a selected deck can be calculated in a Materials List by clicking the **Calculate Structural Materials for Deck** edit button. Any accessories added on the COMPONENTS panel of a deck's Room Specification dialog will be included in a Materials List created using this tool. See *Decks on page 425* and *Components Panel on page 1330*.

## MASTER LIST

 Select **Tools> Materials List> Master List** to open the Master List, a list of previously used materials and any added information such as price or manufacturer. See *The Master List on page 1327*.

## MATERIALS LIST MANAGEMENT

 Select **Tools> Materials List> Materials List Management** to open a list of saved Materials Lists associated with the current plan. See *Saving and Managing Materials Lists on page 1324*.

## GENERATE A REPORT

 When a Live Materials List is active, select **Tools> Materials List> Generate a Report** to create a static version of that list that is no longer actively linked to the model. You can change and add data in a Materials List Report as well as Update to and from the Master List; however, no changes you make will be reflected in the plan. Similarly, any changes made to the plan after a Materials List Report is generated will not be shown in the report.

## MATERIALS LIST PREFERENCES

 The MASTER LIST panel of the Preferences dialog lets you specify the current Master List file and the columns used in it. See *Master List Panel on page 123*.

---

# Creating an Accurate Materials List

In order to take full advantage of Chief Architect's Materials List capabilities, there are several things to keep in mind.

- The accuracy of your Materials List is directly related to the accuracy of your model. Floor and ceiling heights, wall lengths, and structural settings all directly affect Materials List calculations.
- It takes more than just making your drawing look right to generate an accurate Materials List. If, for example, you use CAD lines to draw an item on a floor plan, that item will not be included in the Materials List. A better way would be to use a symbol or structural element. See *Architectural vs CAD Objects on page 158*.
- If you use custom materials, make sure their material definitions are set up correctly. See *Creating Materials on page 1060* and *Materials and the Materials List on page 1063*.
- Bear in mind that using generic objects like Geometric Shapes from the library can result in items being calculated in the Materials List in a manner that you might not expect. See *Other Objects on page 1014*.

## OBJECT INFORMATION AND COMPONENTS

Code, Comment, Manufacturer, and Supplier information can be specified for many objects. See *Object Information Panel on page 1331*.

Price, Extra, Markup, Labor, and Equipment information can also be specified in an object's specification dialog. See *Components Panel on page 1330*.

You can add this information to some objects before they are created in their defaults dialogs. See [Default Settings on page 77](#).

You can also add this information to objects placed from the library. See [Editing Library Objects on page 970](#).

## MATERIAL DEFINITIONS

The material assigned to structural components like walls, floors and ceilings, roofs, and slabs determines how each component is calculated in the Materials List. See [Calculation Methods on page 1063](#).

## FRAMING IN THE MATERIALS LIST

You can specify whether framing materials are calculated by linear foot, as a cut list, or as a buy list in the Structural Member Reporting dialog. See [Structural Member Reporting on page 1306](#).

For more information about how framing appears in the Materials List, see [Framing and the Materials List on page 886](#).

## CUSTOM FORMULAS

Calculations in the Materials List are based on the properties of the objects in the model and the materials assigned to those objects. If the default calculations do not meet your needs, you can replace them with custom formulas. See [Materials List Formulas on page 1320](#).

---

# Structural Member Reporting



Structural Member Reporting allows you to specify how framing members are calculated in the Materials List.

Structural Member Reporting supports multiple saved defaults, which means that you can set up different reporting methods for different purposes. See [Multiple Saved Defaults on page 79](#).

When a Materials List is created, the **Currently Active Default** specified in the Saved Structural Member Reporting Defaults dialog is used. Once created, the default a Materials List references can be changed using the **Structural Member Reporting Control** drop-down in the toolbars. See [Organizing Materials Lists on page 1310](#).

There are four Reporting Methods to choose from:

- **Buy List** calculates the framing materials of the different structural components of the plan by counting individual pieces and matching them to a list of board sizes that you specify.
- **Cut List** calculates the framing materials of the different structural components of the plan by counting the individual pieces present in the model.
- **Linear Length** calculates the framing materials of the different structural components of the plan in linear lengths.
- **Mixed Reporting** calculates framing materials using a combination of linear lengths and piece counts and is recommended for saved Materials Lists in legacy plans.

## SAVED STRUCTURAL MEMBER REPORTING DEFAULTS DIALOG

This dialog lets you manage the saved Structural Member Reporting defaults in the current plan and specify which one is active.

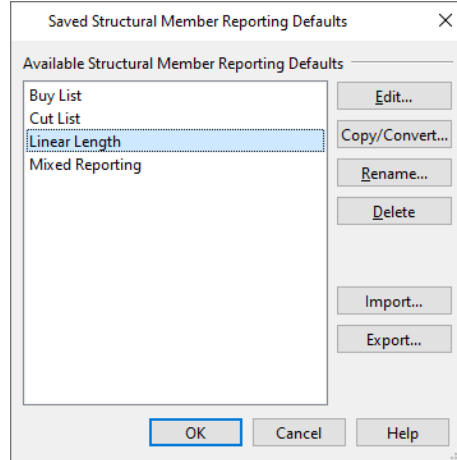

**Available Defaults**

The Structural Member Reporting Defaults in the current plan are listed and can be managed here.

- Click on a name in the list to select it.
- Click the **Edit** button to open the defaults dialog for the selected line item.
- Click the **Copy/Convert** button to create a new Structural Member Reporting Default. See *New Structural Member Reporting Default Dialog on page 1307*, below.
- Click the **Rename** button to open the Rename Current Default dialog and type a new name for the selected default. Names are case-sensitive and must be unique.
- Click the **Delete** button to remove the selected default from the list. This option is not available when there is only one default in the list. Saved Defaults assigned to saved Materials List in the current file cannot be deleted.
- Click the **Import** button to import a Structural Member Reporting Default into the current plan.
- Click the **Export** button to save the selected Structural Member Reporting Default as a **.calumber** file, which can be imported into other plans.

Note: if you click Cancel or press Esc in this dialog after editing, renaming, copying, or importing a Saved Default, your changes will not be retained.

Click **Cancel** to close the dialog without retaining any of your changes. Any newly added Saved Defaults will not be retained.

**NEW STRUCTURAL MEMBER REPORTING DEFAULT DIALOG**

This dialog lets you create a new Structural Member Reporting default and specify its reporting method.

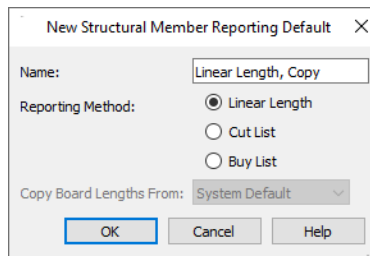

- Type a short, descriptive, unique **Name** for the new Structural Member Reporting default.
- Select which **Reporting Method** the new default will use. Only one default using "Mixed Reporting" can be present in a plan, so this option is not available if one already exists.
- Select a source to **Copy Board Lengths From**. This option is not present if the new default was created by copying a "Buy List", and is only active if Buy List is the Reporting Method selected above.

## STRUCTURAL MEMBER REPORTING DIALOG



To open the Structural Member Reporting dialog, select **Edit> Default Settings**, then select "Structural Member Reporting" from the tree list and click the **Edit** button. See [Default Settings vs Preferences on page 77](#).



You can also open this dialog by selecting **Tools> Materials List> Structural Member Reporting** or by clicking the **Structural Member Reporting** button, which can be added to your toolbars. See [To add a button to a toolbar on page 132](#).

In the Saved Structural Member Reporting Defaults dialog, which opens next, select a default in the list and click the **Edit** button. You can also specify which reporting method is currently set as the default in this dialog. See [Saved Defaults Dialog on page 80](#).

The name of the Saved Default being edited is stated in the dialog box title bar.

Act. Thick	Act. Depth	Length	Type	Treated	Price
1 1/2"	3 1/2"	7'-8 5/8"	Lumber		
1 1/2"	3 1/2"	8'-0"	Lumber		
1 1/2"	3 1/2"	8'-8 5/8"	Lumber		
1 1/2"	3 1/2"	10'-0"	Lumber		
1 1/2"	3 1/2"	12'-0"	Lumber		
1 1/2"	3 1/2"	16'-0"	Lumber		
1 1/2"	5 1/2"	7'-8 5/8"	Lumber		
1 1/2"	5 1/2"	8'-0"	Lumber		
1 1/2"	5 1/2"	8'-8 5/8"	Lumber		

### 1 Format

- The selected default's **Reporting Method** is reported here.
- Select the **Length Units** that you want to use in the Structural Member Reporting dialog as well as in the Materials List. Not available when **Linear Length** is selected.

### 2 Board Sizes

Board Sizes are presented in a table. An effective list will include all types of framing materials that you typically use, as

well as each of the different lengths that you expect to use. Click a column header to sort all line items in the table by that column. An arrow above the column indicates that it is being used to sort the table, and in which direction it is being sorted.

- Click on a line item to select it.
- Click the **Edit** button to open the Board Specification dialog for the selected line item in the table. You can also double-click on a line item to open its Board Specification dialog.
- Click the **New** button to open the Board Specification dialog for a new line item in the table.
- Click the **Delete** button to remove the selected line item from the table.

Note: The Length column is not available for defaults that use the Linear Length Reporting Method.

Items in the **Board Sizes** table are listed in order of priority. If an item in a Materials List could be cut out of more than one item in this table, the program will select the item with the highest priority. Specify the **Priority** of the selected line item in the table.

- Click the **Increase Priority** button to move the selected item one line up in the table. Only available when a line item is selected and it is not first in the list.
- Click the **Decrease Priority** button to move the selected item one line down in the table. Only available when a line item is selected and it is not last in the list.

### 3 Buy List Cut Board Options

- Specify the **Kerf Width**, which is the width of the material lost to the saw blade when a framing member is cut.

### 4 Buy List Options for Long Board Runs

These settings control how to handle framing elements that are typically composed of long runs of multiple collinear boards, such as **Wall Plates and Girts**, **Deck Planking**, and **Rim Joists**. The **Other** category includes any boards or beams that exceed the length of the longest board in the Buy List. There are three options:

- **Report Actual Lengths** reports the lengths of individual long runs.
- **Report Total Linear Length** adds the lengths of all individual long runs and reports the total.
- **Use Longest Buy List Board** calculates the Total Linear Length and reports the number of the longest board in the Buy List required to reach that length. Not available for the **Other** category.

## BOARD SPECIFICATION DIALOG

Click either the **New** or the **Edit** button in the Structural Member Reporting dialog to open the Board Specification dialog, where you can define a line item for the **Boards to buy** table. You also double-click on a line item in the table to modify it.

Board Specification

Actual Thickness: 1 1/2"

Actual Depth: 3 1/2"

Length: 104 5/8"

Type: Lumber  Treated

	Formula	Value
ID	Use Components Panel Formula	Framing
Sub Category	Use Components Panel Formula	
Supplier	Use Components Panel Formula	
Manufacturer	Use Components Panel Formula	
Code	Use Components Panel Formula	
Size	=formatted_width_depth_length	2" x 4" - 8'-8 5/8"
Description	Use Components Panel Formula	fir stud
Count	=board_count	1
Extra		
Price		
% Markup		
Labor		
Equipment		
Total Cost	= (count + extra) * price * (1 + ...	\$0.00
Comment	Use Components Panel Formula	
Label	Use Components Panel Formula	
Accounting Code	Use Components Panel Formula	3110 - Lumber 1st ...

Number Style... OK Cancel Help

- Specify the **Actual Thickness** - as opposed to the nominal thickness - of the selected item in the Buy List table.
- Specify the **Actual Depth** - as opposed to the nominal depth - of the selected item in the Buy List table.
- Specify the **Length** of the selected item in the Buy List table.
- Select the **Type** of structural member from the drop-down list. See *Structure Types on page 886*.
- Check **Treated** if the selected item is a treated lumber product.
- The table is similar to the one found on the COMPONENTS panel in the Framing Specification and other specification dialogs. See *Components Panel on page 1330*.
- Click **OK** to close the dialog and add the information specified here to a line item in the Buy List table.

## Organizing Materials Lists

There are two basic ways to control what items are calculated in the Materials List:

- By specifying which categories and subcategories are used.
- By specifying which layers in the plan are included in the list.

In addition, you can control how much information about each item is included by specifying which columns to display.

You can also use the **Structural Member Reporting Control** drop-down list in the toolbars to choose which method the Materials List uses. See *Structural Member Reporting on page 1306*.

There are some parts of a model that cannot be excluded from the Materials List. Floor and ceiling platforms are prime examples. If you need to generate a Materials List for only part of a plan, such as an addition, consider making a copy of the plan file. In the copy, delete the as-built portion of the plan and then generate a Materials List.

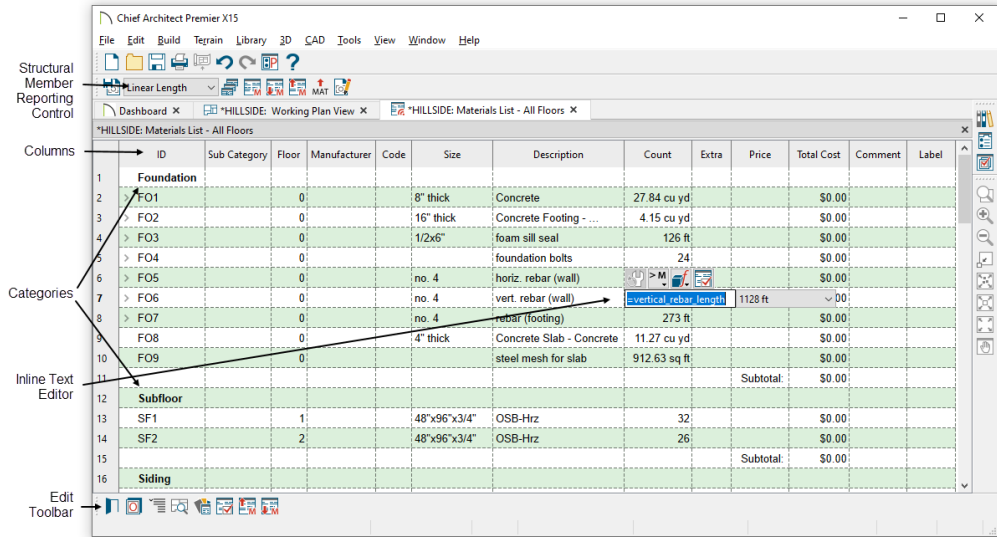

## MATERIALS LISTS AND LAYERS

You can control which objects are included in a Materials List by layer by selecting a Layer Set in the Materials List Specification dialog. See [Options Panel on page 1314](#).

You can also specify which layers are included in a Materials List before it is created by customizing the default Layer Set used by Materials List. See [Layer Set Defaults on page 183](#).

## CATEGORIES

The line items in the Materials List and Master List are organized into a set of predefined categories, such as Electrical and Framing, which display in the **ID** column.

You can specify which category each item belongs to in the Materials List and Master List. In addition, many objects can be assigned to a category prior to generating a Materials List in their specification dialog. See [Components Panel on page 1330](#).

### To specify a line item's category

1. Create a Materials List, open the Master List, or open an object's specification dialog and go to the COMPONENTS panel.
2. Click in the cell in the ID column for a line item.
3. Select the desired category from the drop-down list that becomes available.

The categories that are available cannot be altered; however, you can specify which categories are included in the Materials List in either of two ways:

- In the Materials List Defaults dialog.
- For individual lists in the Materials List Specification dialog. See [Materials List Specification Dialog on page 1312](#).

## SUBCATEGORIES

By default, the Subcategory column of the Materials List is empty for all line items. You can add text to any Subcategory cell by clicking in the cell and typing.

Items can be assigned to a subcategory in the Materials List and, for many items, in their object's specification dialog in the same manner that they can be assigned to a category. See [Components Panel on page 1330](#).

## MATERIALS LIST COLUMNS

Each column in the Materials List reports a different category of information about objects in the list. You can specify most of this information for a variety of objects prior to generating a Materials List. See [Object Components on page 1329](#).

You can also specify which columns are included in the Materials List as well as their order in the Materials List Specification dialog. See [Materials List Specification Dialog on page 1312](#).

## DETAILS DIALOG



For information about one or more selected line items in a Materials List, click the **Details** edit button. The Details dialog displays all Materials List columns for reference, which can be helpful when not all columns are in use in the Materials List. It also lists the Source Object of the selected line item or items.

This dialog will also open when multiple objects located on more than one floor are selected in a Materials List and you click the **Find Object in Plan**  edit button. See [Find Object in Plan on page 691](#).

When one or more line items located on the same floor are selected, click the **Find** button at the bottom of the dialog to view their location in a plan view window.

---

## Materials List Specification Dialog



When a Materials List or the Master List is open, select **Tools > Active View > Edit Active View** to open the Materials List Specification dialog for the current list.

The Master List Specification dialog is similar to this dialog, but only the COLUMNS panel is available. See [The Master List on page 1327](#).



## CATEGORIES PANEL

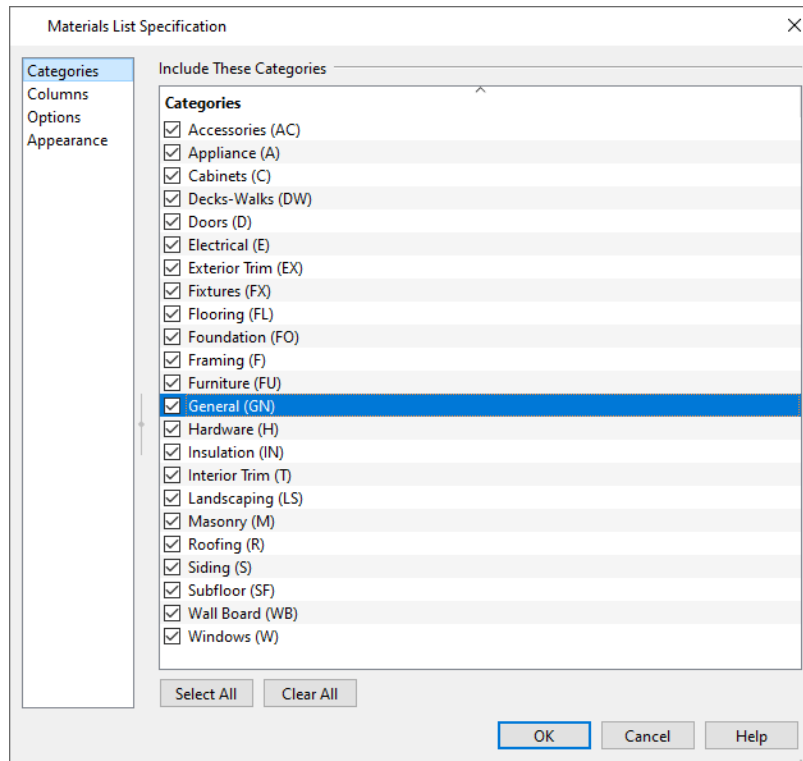

The Categories listed here appear in the ID column of the Materials List in the order they are presented here.

- Check the box beside the name of each category that you want to display in the currently active Materials List.
- Click the **Select All** button to display all categories in the active Materials List.
- Click the **Clear All** button to suppress the display of all categories in the active Materials List.
- Multiple rows can also be selected together using Shift and Ctrl keys. See *Shift and Ctrl Select on page 214*.

Note: The information in a suppressed category is still part of the Materials List. If the Materials List is exported, suppressed categories are exported, as well.

## COLUMNS PANEL

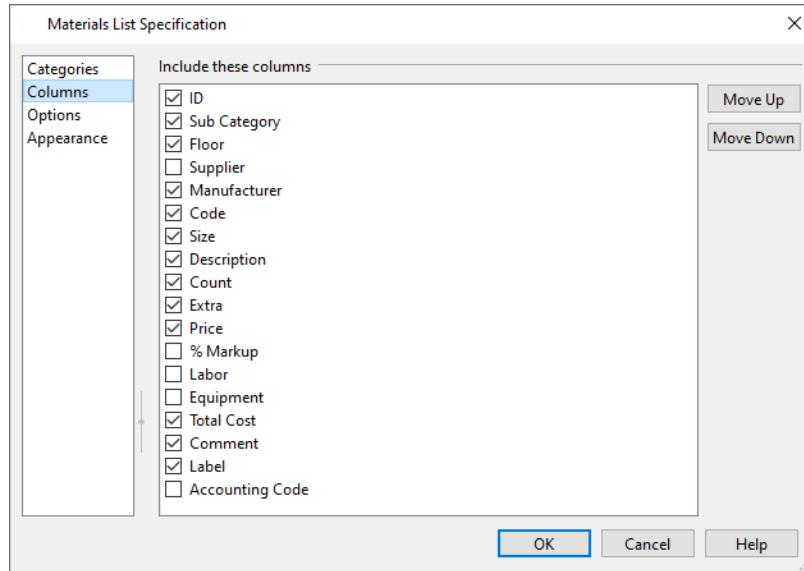

- Check the box beside each column you want to include in the Materials List. To suppress a column's display, remove the check mark next to its name. Columns appear in the Materials List in the order that they display in this list.
- **Move Up** - Click on a column name, then click this button to move that item up one place in the list.
- **Move Down** - Click this button to move the selected column down in the list.

## OPTIONS PANEL

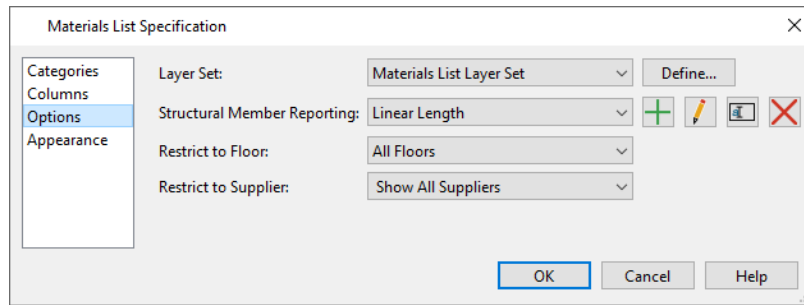

- Select a **Layer Set** from the drop-down list to apply its settings to the currently active Materials List.
- Click the **Define** button to open the Layer Display Options dialog and view or modify the selected Layer Set. See [Layer Display Options Dialog on page 179](#).
- Select a saved **Structural Member Reporting** default from the drop-down list to specify how framing members are counted and reported. See [Structural Member Reporting Dialog on page 1308](#).
- Select a floor level from the **Restrict to Floor** drop-down list to limit the current Materials List to objects on that floor. When "All Floors" is selected, the Materials List includes objects from all floors.
- If you plan to buy materials from multiple suppliers, you can create a Materials List for each. Select an option from the **Restrict to Supplier** drop-down list to only list items associated with the selected supplier; select "Show All Suppliers" to list all items, including those with no supplier; or select "Show Only No Supplier" to only list items that do not have a supplier. Suppliers can be added to this list in the specification dialog for various objects. See [Object Information Panel on page 1331](#).

## APPEARANCE PANEL

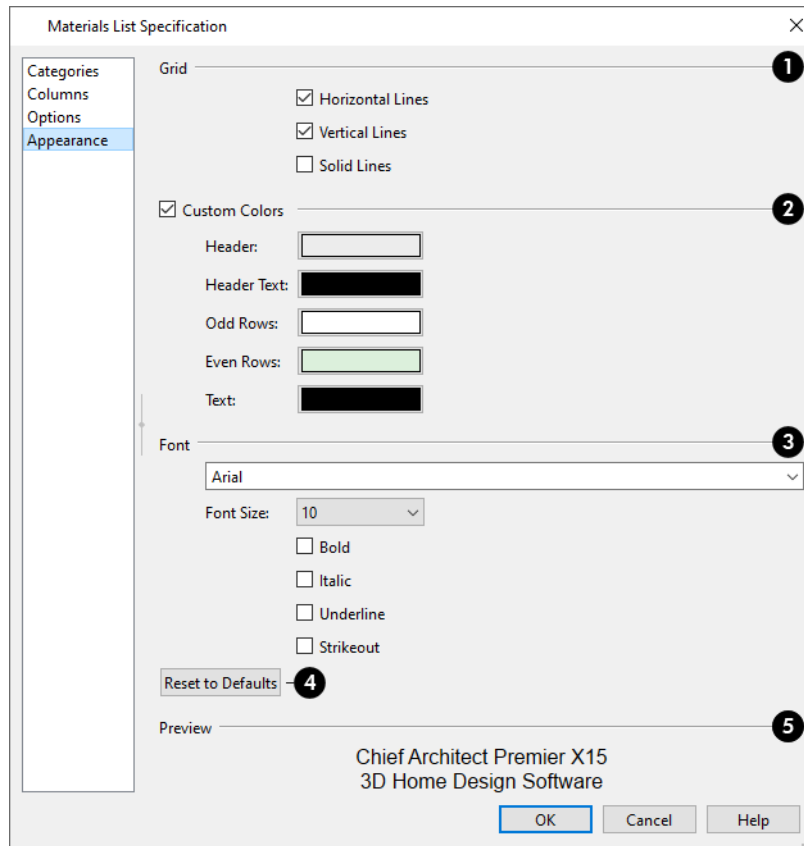

### 1 Grid

- Specify whether you want the cells of the Materials List to be separated by **Horizontal Lines** and/or **Vertical Lines**.
- When **Solid Lines** is unchecked, the Materials List grid uses a dashed line style. Uncheck this to instead have unbroken lines.

### 2 Custom Colors

- When **Custom Colors** is checked, the Materials List uses the colors defined below. When this is unchecked, either the colors associated with the active Color Theme or your operating system's default colors are used.
- Each **Color** box displays the color assigned for various uses in the Materials List. Click a **Color** box to choose a different color. See [Color Chooser/Select Color Dialog on page 203](#).

### 3 Font

- Select a **Font** from the drop-down list.
- Select a **Font Size** from the drop-down list.
- Select one or more font styles: **Bold**, **Italic**, **Underline**, and/or **Strikeout**.

### 4 Reset to Defaults

Click this button to reset all settings on this panel to the installed system defaults.

**5 Preview**

A sample of the selected font and style displays here.

## Materials List Columns

The columns in the Materials List and the Master List are very similar, but not all columns appear in all places.

The following table lists the capabilities of each column:

Column	Available In	Editable In	Description
<b>ID</b>	Materials List, Master List, Components Panel	Materials List, Components Panel	Displays an automatically generated identifier for each line item. Select the cell in this column to change an item's category.
<b>Use</b>	Master List	Master List	A check box beside for line item indicates if it is included in the Materials List.
<b>Sub Category</b>	Materials List, Components Panel	Materials List, Components Panel	Select a cell in this column to change a line item's subcategory.
<b>Floor</b>	Materials List	N/A	States the floor that the line item is located on. See <i>Multiple Floors on page 730</i> .
<b>Label</b>	Materials List, Master List, Components Panel	Materials List	Lists the label that displays in plan view for most items that have labels associated with them. See <i>Label Panel on page 700</i> .
<b>Supplier</b>	Materials List, Master List, Components Panel	Materials List, Master List, Components Panel	Specify a supplier for the item. A Supplier in the Master List is not used if one has been entered in the object's specification dialog.
<b>Manufacturer</b>	Materials List, Master List, Components Panel	Materials List, Master List, Components Panel	Specify a manufacturer for the item. A Manufacturer in the Master List is not used if one has been entered in the object's specification dialog.
<b>Code</b>	Materials List, Master List, Components Panel	Materials List, Master List, Components Panel	Specify a Code, such as an SKU, for the item. A Code in the Master List is not used if one has been entered in the object's specification dialog.
<b>Size</b>	Materials List, Master List, Components Panel	Materials List, Components Panel	Click in a cell to edit the size description of the line item. To restore the original size, delete the text you typed in. For a blank cell, type a single blank space.
<b>Description</b>	Materials List, Master List, Components Panel	Materials List, Components Panel	Click in a cell to edit the description of the line item in the same way that the Size can be edited.

Column	Available In	Editable In	Description
<b>Quantity</b>	Master List	Master List	Specify how many of an item must be found before information from the Master List is applied to it in a Materials List. If at least this many items are found, price, supplier, and other information is used.
<b>Count</b>	Materials List, Components Panel	Components Panel	This is the actual number of an item, either associated with the selected object or in the Materials List. Count can be increased for accessories added to a selected object.
<b>Extra</b>	Materials List, Components Panel	Materials List, Components Panel	Specify an additional amount of the line item. Changes made in the object's specification are reflected in the Count column in the Materials List.
<b>Price</b>	Materials List, Master List, Components Panel	Materials List, Master List, Components Panel	This is the per-unit price of an item. A Price in the Master List is not used if one has been entered in the object's specification dialog.
<b>% Markup</b>	Materials List, Master List, Components Panel	Materials List, Master List, Components Panel	Specify a markup percentage for the item. A markup in the Master List is not used if one has been entered in the object's specification dialog.
<b>Labor</b>	Materials List, Master List, Components Panel	Materials List, Master List, Components Panel	Specify a labor cost for the item. A Labor value in the Master List is not used if one has been entered in the object's specification dialog.
<b>Equipment</b>	Materials List, Master List, Components Panel	Materials List, Master List, Components Panel	Specify an equipment cost related to the item. An Equipment value in the Master List is not used if one has been entered in the object's specification dialog.
<b>Total Cost</b>	Materials List, Components Panel	Materials List, Components Panel	This is the total cost based on Count, Price, % Markup, Labor and Equip values.
<b>Default</b>	Master List	Master List	Click in this column to specify the line item as the default when more than one item is available.
<b>Comment</b>	Materials List, Master List, Components Panel	Materials List, Master List, Components Panel	Additional information related to the item can be entered here. A Comment in the Master List is not used if one has been entered in the object's specification dialog.
<b>Accounting Code</b>	Materials List, Master List, Components Panel	Materials List, Master List, Components Panel	The Accounting Code information is used when a materials list is exported for use in BuilderTREND software.

## Editing Materials Lists

Materials Lists can be edited in a variety of ways. You can adjust the width of a column by clicking and dragging the bar on the right side of the column name.

### EXPAND AND COLLAPSE ROWS

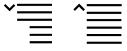
 If a line item has an arrow to the left of its name in the ID column, it represents multiple individual objects. Click the **Expand** edit button to display these individual objects as separate line items; click the **Collapse** edit button to hide them. You can also click the arrow to the left of the name to expand or collapse the line items. This option is not available in Materials List Reports.

### FIND OBJECT IN PLAN

 To find out where a line item in the Materials List is located in the model, select its row or any cell in its row and click the **Find Object in Plan** edit button. This option is not available in Materials List Reports. See [Find Object in Plan on page 691](#).

### ADDING INFORMATION

You can enter information in the Price, Supplier, Code, Comment and Manufacturer columns for each line item in both a live Materials List and a Materials List Report.

Adding price or other information for any item is straightforward. Simply click in the cell and type the desired information. When the information is correct, you can add it to the Master List. See [Adding to the Master List on page 1328](#).

You can switch between several existing suppliers or manufacturers for a given item by double-clicking on the right side of the cell in an appropriate column. A drop-down arrow displays to the left of the cell. Click it to view a list of suppliers or manufacturers for that item and select one.

When a Materials List is calculated, you can have the program search the Master List for Price, Supplier, and Code information for each item by selecting **Tools> Update From Master List** . The information used is marked as “Default” in the Master List. See [Materials List Columns on page 1317](#).

### CHANGING INFORMATION

Although the information in some columns cannot be saved to the Master List, you can change the information in any column in an individual Materials List or Materials List Report. As with added information, click in a cell to select the existing text, then type in the desired text.

To move a line item to a new category, select the cell in the **ID** column and choose a new category from the drop-down list that becomes available. You can also select a subcategory by clicking in the cell in the **Sub Category** column. See [Categories on page 1311](#).

### CHANGING COUNT UNITS

The material for a given object component will be counted either by piece; linear feet or meters; square feet or meters; or cubic yards or meters. The same method and unit used in the Count column will be used in the Extra column.

When the Count is linear, area, or volume, you can choose a different unit of measurement:

- Double-click in a cell in the Count column to select and edit it, then choose a unit of measurement from the drop-down list to the right of the selected cell.
- You can also click the **Number Formatting**  button when a Count cell is selected to specify the units and accuracy of the value in the selected field. The specified unit is also used in the Extra field for that row. See *Number Formatting Dialog on page 1321*.

## MATERIALS LIST FORMULAS

Calculations in the Materials List are based on the properties of the objects in the model and the materials assigned to those objects. If the default calculations do not meet your needs, you can replace them with custom formulas. You can also add formulas to cells that do not have automatic calculations. See *Materials List Formulas on page 1320*.

### COUNT AND FORMULA TOOL TIPS

Whenever you mouse over a cell in the Materials List that is either in the Count column or contains a formula of any kind, a Tool Tip will display, providing information about the cell's contents. When the Count is a total length, area, or volume, it may be rounded. The Tool Tip will show the value with greater accuracy.

### TOTAL COST

By default, the Total Cost for a line item is calculated using the Count, Price, % Markup, Labor and Equipment columns to calculate the cost. The formula used is:

$$(\text{Count} + \text{Extra}) * \text{Price} * (1 + (\% \text{ Markup}/100)) + ((\text{Count} + \text{Extra}) * \text{Labor}) + ((\text{Count} + \text{Extra}) * \text{Equipment})$$

If a column does not appear, 0 is used for the value of that column with the exception of Count and Price, which are always used in the calculation even if they are not shown.

### COPYING INFORMATION

Portions of a Materials List can be copied and then pasted into a **Text**  object or into a word processing program or spreadsheet program using the standard Windows Copy (Ctrl + C), Cut (Ctrl + X), and Paste (Ctrl + V) commands. See *Copying and Pasting Text on page 514*.

### CHANGING THE APPEARANCE

The grid lines, colors, and font used for Materials Lists and the Master List can be specified in Materials List and Master List Specification dialogs. See *Appearance Panel on page 1315*.

---





## Materials List Formulas

Calculations in the Materials List are based on the properties of the objects in the model and the materials assigned to those objects. See *Define Material Dialog on page 1066*.

If the default calculations do not meet your needs, you can replace them with custom formulas. Materials List formulas use Ruby syntax, which allows you to use basic arithmetic as well as construct more complex macros. See *Creating User Defined Macros on page 1387*.



**To insert a custom Materials List formula**

1. Double-click in any editable cell in the Materials List or on the COMPONENTS panel of an object's specification dialog to select and edit it. See [Components Panel on page 1330](#).
  - The cells in some columns allow you to choose an item from a drop-down list.
  - Most cells are editable text fields that have a contextual toolbar of editing tools above them when selected.
  - When the cell is in the Count column, click the **Number Formatting**  button to specify the units and accuracy of the value in the selected field. You can also select a Count unit from a drop-down list to the right of the cell. The specified unit is also used in the Extra field for that row.
2. In the inline text field, you can:
  - Type the desired custom text that you need. The resulting text does not perform calculations and is static.
  - Press the = key, then type or insert the desired custom formula. The = character at the beginning tells the formula to treat the text that follows as a formula instead of regular text.
  - Click the **Insert Macro**  button to insert one or more User Defined, Materials List Column, Object Specific, and/or Parent Object macros into the inline text field. The options that are available vary by object type.
3. When using a formula or macro:
  - Select **Apply Formula to Line Item**  to create a custom formula that uses one or more Materials List Column macros, which report data from others cells in the same row of the Materials List or Report.
  - Select **Apply Formula to Source Object**  to create a custom formula that uses one or more User Defined, Object Specific, or Parent Object macros, which report data associated with the object's attributes or those of its parent object. Not available in Materials List Reports.
4. If the cell has been previously edited, you can click the **Revert to Default**  button to restore the original, automatically generated content.

Fields with custom macros report values with accuracy of up to two decimal points, even in columns that report whole numbers when calculated automatically.

**NUMBER FORMATTING DIALOG**

Right-click in a cell in the Count or Extra column of the Materials List and select **Number Formatting** from the contextual menu. This edit button is also available when a cell in either of these columns is selected. See [The Edit Toolbar on page 130](#).

In the Number Formatting dialog, you can specify the units, formatting, and accuracy of the value in that cell. The settings in this dialog are also found in the Displayed Line Length Format dialog. See [Displayed Line Length Dialog on page 293](#).

**CUSTOM FORMULA MACROS**

You can create custom macros in the Edit Text Macro dialog and then insert them into the inline text field. See [Edit Text Macro Dialog on page 1397](#).



- Macros created for use in Materials List formulas need to have **Evaluate** checked in the Edit Text Macro dialog.
- Formulas that reference the object's properties need to have "Owner Object" selected as the **Context**.
- Formulas that reference information in other cells in the current row need to have "Materials List Line Item" selected as the **Context**.

Note: Custom formulas in legacy plan files may use deprecated behavior for measurement values. See *Migrating Legacy Ruby Code on page 1401*.

## Materials List Polylines

 A **Materials List Polyline** lets you create a Materials List that only includes objects within its area. The materials list Categories and floor levels included in the Materials List can be set in advance in the Materials List Polyline./Area Defaults dialog.

### To create a Materials List Polyline

1. In plan view, select **Tools > Materials List > Materials List Polyline** and draw a rectangular polyline.
2. Select the Materials List Polyline and click the **Open Object**  edit button.
3. On the MATERIALS LIST panel of the Materials List Polyline Specification dialog, specify which categories and floor levels you want to include in the materials calculation, along with how you want objects within the polyline to be selected. See *Materials List Polyline Specification Dialog on page 1322*.
4. Edit the polyline's position and shape as needed. See *Editing Closed Polyline-Based Objects on page 228*.
5. With the Materials List Polyline still selected, click the **Calculate Materials List**  edit button. A Materials List is created for objects within the polyline.

 To prevent an area from the middle of a Materials List Polyline from being included in a Materials List, use a polyline hole. See *Polyline Holes on page 232*.

If a Materials List Polyline is configured in such a way that it includes a room, a Materials List created from it will include the floor and ceiling finish materials and substrate materials like sheathing and insulation for the entire room: not just within the polyline.

You can also convert a closed CAD polyline into a Materials List Polyline using the **Convert Polyline**  edit tool. See *Convert Polyline on page 262*.

## Materials List Polyline Specification Dialog

 To open the Materials List Polyline Specification dialog, select one or more Materials List Polylines and click the **Open Object** edit button.

The settings in this dialog are also found in the Materials List Polyline Defaults dialog.

## MATERIALS LIST PANEL

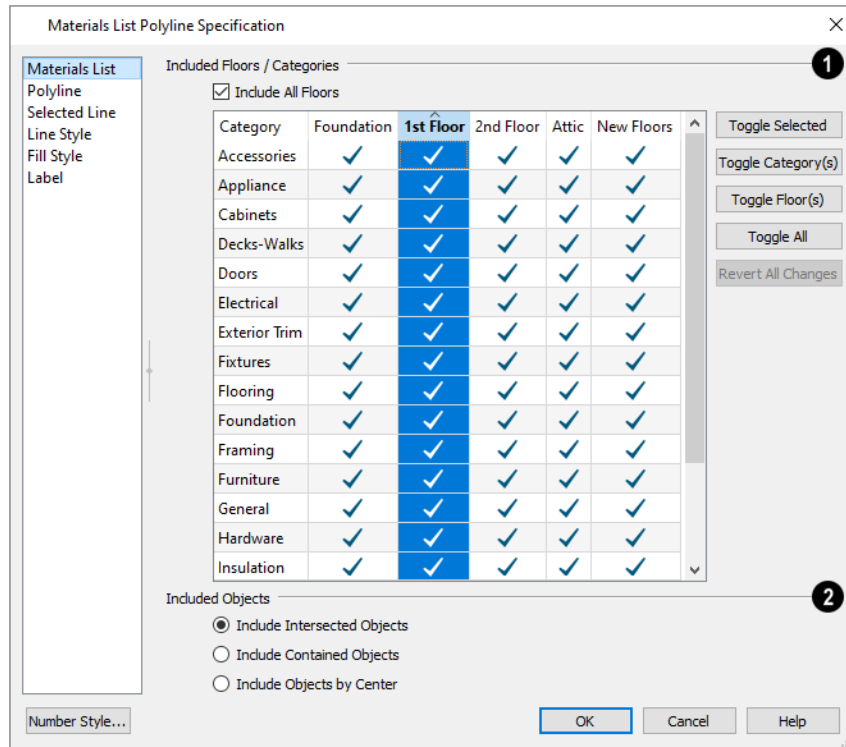

### 1 Included Floors/Categories

Specify the **Included Floors/Categories** in a Materials List generated from the selected Materials List Polyline. The table lists all Materials List categories in its rows and all floor levels in the current plan in its columns.

- A check mark in a field indicates that the category of object on a particular floor will be included in the Materials List. Click to add or remove the check mark.
- Click on the name of a Category to select that row, or click on a floor level name to select that column. Multiple categories or floor levels can also be selected, as can multiple fields. See *Shift and Ctrl Select on page 214*.
- Uncheck **Include All Floors** to show only the floor level that the selected Materials List Polyline is located on in the table.
- Click the **Toggle Selected** button to add or remove a check mark from the selected field(s), row(s), or column(s).
- Click the **Toggle Category(s)** button to add or remove check marks from the selected row(s).
- Click the **Toggle Floor(s)** button to add or remove check marks from the selected column(s).
- Click the **Toggle All** button to add or remove check marks from the selected column(s).
- Click the **Revert All Changes** button to restore the selections that were present when the dialog was first opened.

### 2 Included Objects

The **Included Objects** options control which objects are included in the Materials List based on their position relative to the selected Materials List Polyline.

- Choose **Include Intersected Objects** to include any objects whose bounding boxes are intersected by or located within the polyline.
- Choose **Include Contained Objects** to include only objects located entirely within the polyline.
- Choose **Include Objects by Center** to include only objects whose center points are located within the polyline.
- If multiple polylines with different settings are selected, **No Change** may be an additional option. Select this to retain the polylines' original settings.

## POLYLINE PANEL

The POLYLINE panel states information about the polyline's shape, including the total length of its **Perimeter**, its enclosed **Area**, and the **Number of Lines** that make up its perimeter. See *Line Specification Dialog on page 304*.

## SELECTED LINE/ARC PANEL

The SELECTED LINE panel is available when the selected cloud edge is a line as opposed to an arc. See *Line Specification Dialog on page 304*.

The SELECTED ARC panel is available when the selected segment of the cloud edge is an arc as opposed to a line. See *Arc Panel on page 312*.

See, too, *Selected Edge on page 212* and *Change Line/Arc on page 256*.

## LINE STYLE PANEL

For information about the settings on this panel, see *Line Style Panel on page 305*.

## FILL STYLE PANEL

The FILL STYLE panel is found in various dialogs throughout the program. See *Fill Style Panel and Dialogs on page 193*.

## LABEL PANEL

Materials List Polyline labels display when the "Polylines, Labels" layer is turned on and use the Text Style assigned to that layer. See *Text Styles on page 538*.

For more information about the settings on this panel, see *Label Panel on page 700*.

---

# Saving and Managing Materials Lists

There are a number of ways to save and manage Materials Lists. See *View Windows on page 144*.





Select **Tools > Active View > Save Active View** to save any changes that you may have made to a Live Materials List's attributes, including settings in its specification dialog and column widths. If the Materials List has not been previously saved, the Save Materials List dialog will open, allowing you to type a short, descriptive name for the list. If its attributes have been modified, you will also be prompted to save a Live Materials List when you close its window. **Save Active View** can also be used to save changes to attributes and data in a static Report.



Select **Tools> Materials List> Generate a Report** to save the current Live Materials List as a static Report that is no longer actively linked to the model.

 You can also use **Tools> Active View> Save Active View As** to create an exact copy of the current Live Materials List or static Report. You will be prompted to give the new view a name.

 Select **Tools> Active View> Edit Active View** to open the specification dialog for the currently active Live Materials List or Report. See *Materials List Specification Dialog on page 1312*.

 Saved Materials Lists and Reports can be accessed, renamed, duplicated, and deleted in the Project Browser. See *Project Browser on page 58*.

Once a Materials List has been saved, it is also listed in the Materials List Management dialog.

## MATERIALS LIST MANAGEMENT DIALOG

 Select **Tools> Materials List> Materials List Management** to open the Materials List Management dialog.

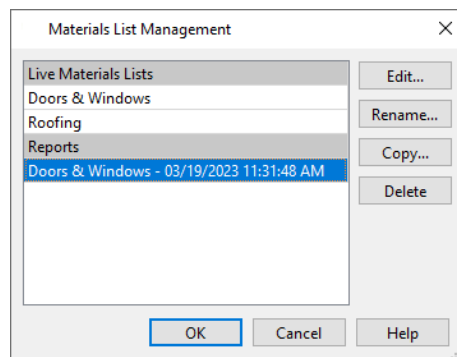

All Live Materials Lists and Reports are listed here. Click on an item in the list on the left to select it.

- **Edit** - Open the selected Materials List or Report. You can also double-click an item in the list.
- **Copy** - Create a copy of the selected Materials List or Report. Type a new name for it in the Save Materials List dialog.
- **Rename** - Open the Rename Materials List dialog and type a new name for the list or Report.
- **Delete** - Remove the selected Materials List or Report from the current plan.

---

## Printing and Exporting the Materials List

There are several options for printing and exporting the information in a Materials List.

 To print a Materials List, select **File> Print** while the Materials List window is active. See *Print View Dialog on page 1380*.

 A Materials List can also be exported into a one of several different file formats that can be opened by various programs. In a Materials List window, or in the Master List, select **File> Export Materials List** to open the Export Materials List dialog.

## EXPORT MATERIALS LIST DIALOG

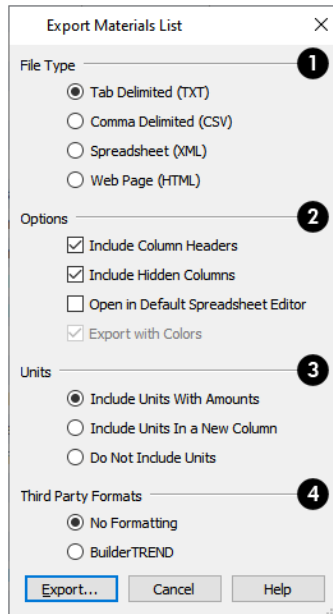

### 1 File Type

Specify the **File Type** that you would like to export to.

- Select **Tab Delimited (TXT)** to create a text file with a tab between each field entry in the Materials List, and a carriage return between each row.
- Select **Comma Delimited (CSV)** to create a text file with a comma between each field entry in the Materials List and a carriage return between each row.
- Select **Spreadsheet (XML)** to create a file that can be opened by Microsoft Excel.
- Select **Web Page (HTML)** to create an html file that you can view with a web browser.

### 2 Options

Additional export options are available here.

- Uncheck **Include Column Headers** to prevent column headings from appearing in the first row of the exported file. Column headers are always included in HTML files.
- Uncheck **Include Hidden Columns** to only export columns currently displayed in the active Materials List. When this is checked, all columns are exported, regardless of whether they are currently displayed.
- Check **Open in Default Spreadsheet Editor** to open the exported file with the program specified on your computer when you finish exporting.
- When XML or HTML is selected above and **Export with Colors** is checked, the Color Theme or Custom Colors used in the Materials List are exported. When unchecked, the white and pale gray fill and black text are used.

### 3 Units

Specify how **Units** of measurement are exported. Currency information is always exported, regardless of the option chosen

here.

- Select **Include Units with Amounts** to include units in the same column as the associated value.
- Select **Include Units in a New Column** to report units as text in a new column.
- Select **Do Not Include Units** to not export units at all.

#### **4** Third Party Formats

- Select **No Formatting** to export the materials list data using the formatting used in the Chief Architect Premier Materials List.
- Select **BuilderTREND** to export the materials list data for use in BuilderTREND software. When this is selected, the only File Type available above is Comma Delimited (CSV).

When you click OK, the Write Materials Export File dialog will open. This is a typical File Save dialog. See [Exporting Files on page 41](#).

## ESTIMATING SOFTWARE

You can export a Materials List to a word processor or spreadsheet program to arrange it in your estimating format. You can also export the Materials List to a number of commercial estimating programs in whose databases you can keep your current pricing, labor costs, and markups and generate reports based on this data.

Before purchasing an estimating software program, be sure that the program supports the direct import of Chief Architect Materials Lists.

Any questions regarding estimating software packages and how they interact with Chief Architect should be directed toward the company providing the estimating software. Chief Architect Software is unable to provide any technical support for third party programs.

---

## The Master List



The **Master List** saves price, supplier, manufacturer, and other information about items in your Materials Lists and allows you to apply that information to items in future Materials Lists. Select **Tools> Materials List> Master List** to open the Master List.

Chief Architect allows you to have more than one Master List. Only one can be active, however, and only the active list is updated with new information. You can specify which Master List is active in the Preferences dialog. See [Preferences Dialog on page 95](#).

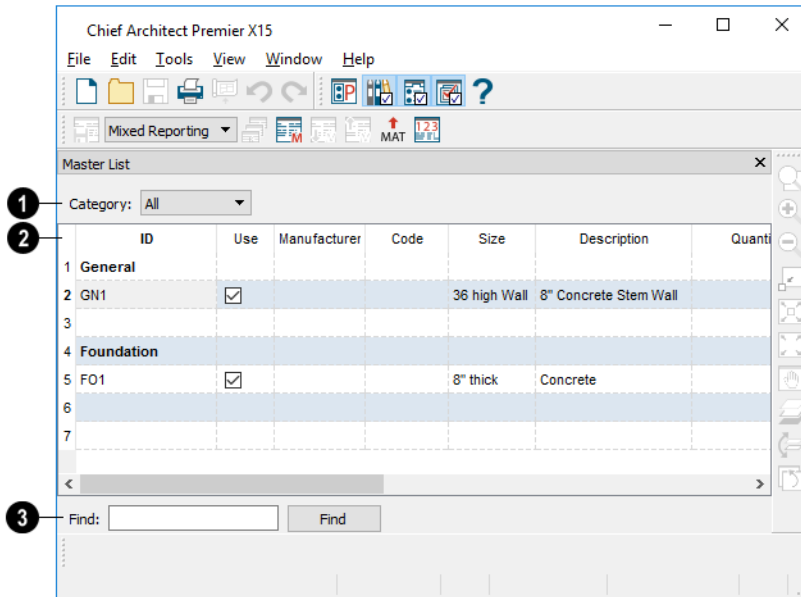

### 1 Category

The **Category** drop-down list at the top left corner of the window lets you select one particular category of items to display, or all categories. See [Categories on page 1311](#).

### 2 Columns

As with individual Materials Lists, you can specify which columns display in the list. See [Materials List Specification Dialog on page 1312](#).

### 3 Find

Use the **Find** field near the bottom of the window to search for text in the Master List.

The search starts from the currently selected cell and moves to the right, then moves down to the next row starting at the left column, and so on, until it finds an instance of the text you entered.

## ADDING TO THE MASTER LIST

You can edit line items in a Materials List and then add them to the Master List for future use.

### *To use Update to Master List*

1. In a Live Materials List or Materials List Report, add or change information in any editable column for a line item.
2. Select the line item by clicking on its line number on the left side of the list. When selected, then entire line becomes highlighted.
3. Select multiple adjacent rows by holding down the Shift key while clicking. See [Shift and Ctrl Select on page 214](#).
4. Select **Tools> Update to Master List** . The information in the selected line is saved in the Master List.
  - If an item in the Master List is listed in the same Category and has the same Size, Description, and Label information as the selected line item, it will be updated.
  - If no item in the Master List matches the selection, a new line item in the Master List will be created.

Once Master List information exists for a particular item, you do not need to enter it again until you want to update it.



## UPDATE FROM MASTER LIST

Similarly, items in a Materials List can be updated to include information in the Master List.

### *To use Update from Master List*

1. When a Materials List is active, click on a row number to select the row.
2. Select **Tools> Update from Master List**  to have the program search the Master List for a record for the selected line item. If an identical record is available, its information is included in the Materials List.
  - Multiple rows can be selected by clicking on one row number, then holding down the Shift key and clicking on additional row numbers.
  - Select all rows by clicking the cell at the top left corner of the Materials List, above the row numbers.

If the Master List contains more than one record for an item, the program references the last one entered. You can override this by defining one specific entry as the default. This is achieved by clicking on the check box in the Def column.

The **Master List** is almost identical to a Materials List, but has a few additional controls to help with viewing.

## EDITING THE MASTER LIST

In the Master List, existing line items can be modified or deleted. For information about the editability of columns in the Master List, see [Materials List Columns on page 1317](#).

Often, the Master List will include items that you may not want to include in all Materials Lists.

- Check boxes in the **Use** column indicate whether each item is included in the Materials List. If **Use** is unchecked, the item is not included. This is useful in cases where several line items will be purchased as a single unit.
- This **Quantity** column is used to specify how many of an item must be found before information from the Master List is applied to it in a Materials List. If at least this many of the item are found, price, supplier, and other information is used. **Quantity** is useful for applying a quantity discount.
- When more than one line item is available for a specific component or accessory, the **Default** column indicates which item is to be used. Click this column to specify this item as the default. This is useful when a line item has been updated to the Master List more than once with different price, supplier or other information.

To delete a row from the Master List, click on the row number at the far left. The entire row highlights. Select **Edit> Delete**, click the **Delete**  button, or press the Delete key on your keyboard.



---

## Object Components

Many architectural objects in the program, from walls to cabinets to images, have components associated with them that are calculated in the Materials List and can be listed in schedules. For example, base cabinets have cabinet box and countertop components.

In addition to their components, some objects also have subcomponents. Cabinet boxes, for example, have doors, drawers and hardware.

Components and subcomponents are specified on the COMPONENTS panel of many object specification dialogs.

You can also add and edit information for objects and their accessories in the Materials and Master Lists. See [Editing Materials Lists on page 1319](#).

## COMPONENTS PANEL

- Select one or more objects of the same type and click the **Open Object** edit button to open their specification dialog. The information on the COMPONENTS panel is the same as the Materials List line item(s) for the selected object.

The information on the COMPONENTS panel can also be edited for objects in the User Catalog of the Library Browser. See [Editing Library Objects on page 970](#).



If the component of an object is modified in a Live Materials List, that change will also be made on the Components panel of that object's specification dialog. See [Editing Materials Lists on page 1319](#).

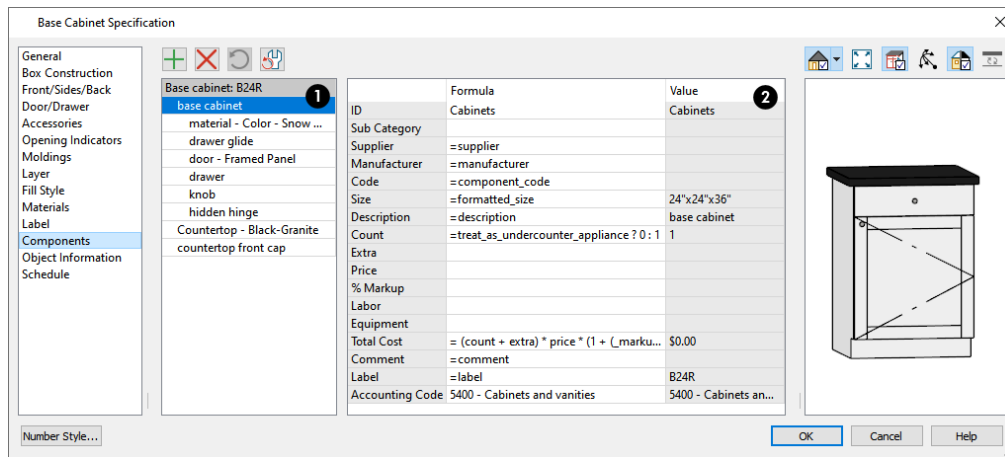



The selected object's components and their attributes are listed in two tables.

### 1 Components

The selected object's components and subcomponents are listed here.

- Subcomponent names are indented to help distinguish them from main components.
- Click on a line item to select it and display its Materials List information to the right.

The buttons above the table allow you to manage this list.

- When a component is selected, click the **Add Line Item**  button to add a new component to the list. When a subcomponent is selected, a new subcomponent is created instead.
- Click the **Remove Line Item**  button to remove the selected line item from the list.
- Click the **Restore**  button to return to the list any previously removed components or subcomponents. Only available when line items have been removed. User-created line items that have been removed are not affected by this option.

- Click the **Revert**  button to reset any Formulas customized below. In the Cabinet Specification dialogs, they are reset to the values set in the corresponding Cabinet Defaults dialog; in the Cabinet Defaults dialogs, they are reset to the system defaults.

## 2 Materials List Data

- The left column is a list of column headings found in the Materials List. See *Materials List Columns on page 1312*.
- The middle column displays the **Formula** used to calculate each row. Click in a cell in this row to add or edit a formula. See *Materials List Formulas on page 1320*.
- The **Value** resulting from each formula is shown for reference in the right column.

Additional information about how values are calculated may display below the table for some objects: notably, rooms and terrain features.

Note: The Label can be edited on the Label panel of the object's specification dialog. See *Label Panel on page 700*.

---

## Object Information Panel

 The OBJECT INFORMATION panel is found in the specification and defaults dialogs for a variety of different objects. The settings on this panel let you specify information that can then be included in the Materials List and Schedules. See *Materials List Columns on page 1317* and *Columns to Include on page 689*.

 If an object's information is modified in a Live Materials List, that change will also be made on the Object Information panel of that object's specification dialog. See *Editing Materials Lists on page 1319*.

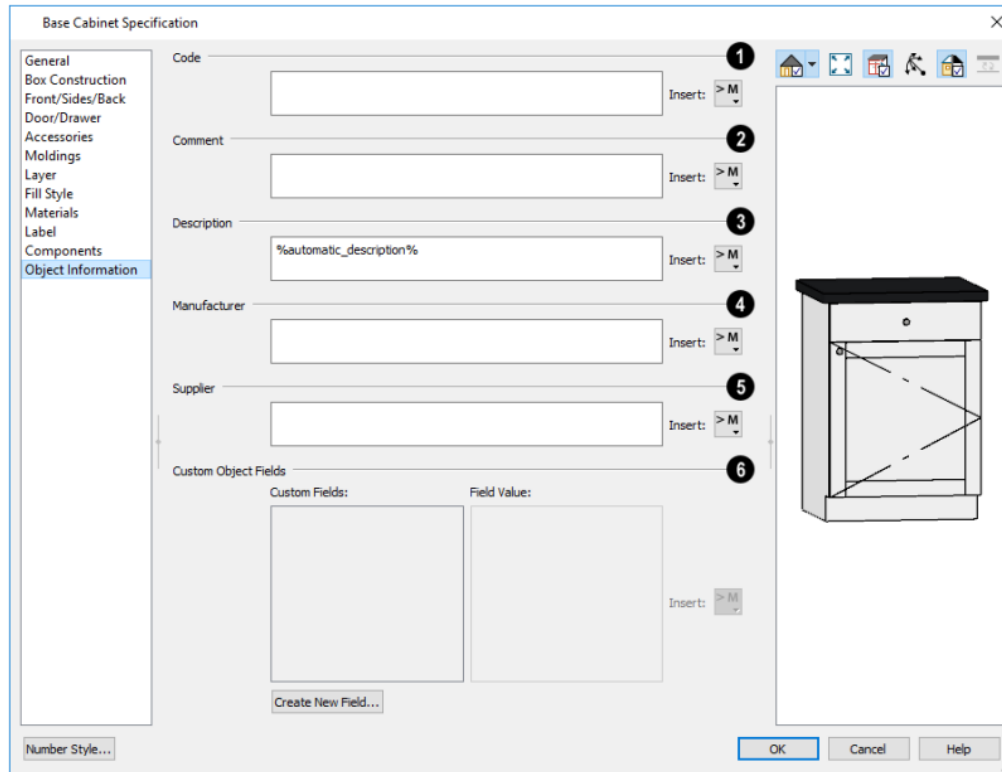

**1 Code**

Specify a **Code**, such as an SKU, for the selected object.

**2 Comment**

Specify a **Comment** for the selected object.

**3 Description**

Specify a **Description** for the selected object.

**4 Manufacturer**

Specify the selected object's **Manufacturer**.

**5 Supplier**

Specify the selected object's **Supplier**.

**6 Custom Object Fields**

The **Custom Object Fields** settings allow you to specify custom field values for use in schedules. See *Custom Object Fields on page 690*.

- A list of **Custom Fields** available in the current plan displays on the left. Click on a name to select it.
- A **Field Value** for the selected Custom Field can be created or edited in the text field on the right. Individual objects can have different Field Values for the same Custom Field.

Click the **Insert Macro** button to the right of any of these text fields to insert a macro. See *Text Macros on page 540*.

# Layout

## Chapter 41

The Chief Architect layout facility provides a set of easy to use tools for creating printed construction documents. You can create your own title block and border, then arrange multiple views of a plan, details, notes, and more on a page for printing.

Each layout file can contain many pages, each of which can contain multiple views, details, images, CAD objects, text, or contents and revision tables.

For detailed information about printing in Chief Architect, see *Printing and Plotting on page 1363*.

### TOPICS

<b>Layout Preferences and Defaults</b> .....	<b>1334</b>
<b>The Layout Tools</b> .....	<b>1335</b>
<b>Creating a Layout File</b> .....	<b>1336</b>
<b>CAD and Text in Layout</b> .....	<b>1337</b>
<b>Pictures, Metafiles, and PDFs in Layout</b> .....	<b>1338</b>
<b>Sending Views to Layout</b> .....	<b>1338</b>
<b>Keeping Layout Views Current</b> .....	<b>1341</b>
<b>Displaying Layout Views</b> .....	<b>1344</b>
<b>Editing Layout Views</b> .....	<b>1345</b>
<b>Editing Layout Lines</b> .....	<b>1348</b>
<b>Layout Box Specification Dialog</b> .....	<b>1349</b>
<b>Opening Layout Views</b> .....	<b>1353</b>
<b>Managing Layout Links</b> .....	<b>1353</b>
<b>Layout Page Management</b> .....	<b>1355</b>
<b>Layout Page Information</b> .....	<b>1358</b>
<b>Layout Page and Revision Tables</b> .....	<b>1361</b>
<b>Printing Layout Files</b> .....	<b>1361</b>
<b>Exporting Layout Files</b> .....	<b>1362</b>

---

## Layout Preferences and Defaults

There are a number of defaults and preference settings that affect layout files.



You can specify the background color of the drawing area in layout files on the COLORS panel of the Preferences dialog. See [Colors Panel on page 98](#).



To access the layout defaults for the current layout file, select **Edit> Default Settings**. The options in the Default Settings dialog are similar to those found in this same dialog in a plan file, although there are fewer choices in the list because only CAD objects, dimensions, and text can be drawn on layout pages. See [Default Settings on page 77](#).

### GENERAL LAYOUT DEFAULTS

The settings in the General Layout Defaults dialog control basic features of the Chief Architect environment in the current layout file. As with other default settings, they are file specific, which means that they can be set differently in individual layout files. To open this dialog, select **Edit> Default Settings** , select "Layout", and click the **Edit** button. The settings in this dialog are also found in the General Plan Defaults dialog. See [General Plan Defaults Dialog on page 92](#).

### DRAWING SHEET SETUP

The settings in the Drawing Sheet Setup dialog are file-specific and are particularly important considerations in layout files. See [Drawing Sheet Setup Dialog on page 1367](#).

### LAYOUT PAGE DISPLAY OPTIONS



Select **Tools> Layer Settings> Display Options** to open the Layout Page Display Options dialog.

This dialog is similar to the Layers Display Options dialog, but controls only the display of objects drawn on the layout page, such as CAD objects, text, dimensions, and imported objects. The display of layout view boxes is also controlled by the Layout Page Display Options - but not the objects within those views.

For information about how to use this dialog, see [Layer Display Options Dialog on page 179](#).

For information about controlling the display of objects in views sent to layout, see [Displaying Layout Views on page 1344](#).

### LAYOUT BOX DEFAULTS

The default line style, fill style, and label format for layout boxes can be set in the Layout Box Defaults dialog. See [Layout Box Specification Dialog on page 1349](#).

### PAGE TEMPLATES

In addition to the default settings available in layout files, you can create one or more Page Templates. Page Templates let you create features like a title block and border and then apply those features to any of the pages of your layout that you wish. See [Layout Page Templates on page 1358](#).

### LAYOUT FILE TEMPLATES

You can customize layout default settings and Page Templates for future layouts and create a template. See [Template Files on page 87](#).

## The Layout Tools

 There are a variety of tools available to send views to layout and edit them, as well as manage layout pages and links.

Many of the tools available in layout are described in the Printing chapter. See *The Printing Tools on page 1366*.

### SENDING VIEWS TO LAYOUT

 Select **File> Send to Layout** to open the Send to Layout dialog and send the current view to the specified layout page. See *Sending Views to Layout on page 1338*.

 In plan view, select a saved cross section/elevation view symbol and click the **Send Camera's View to Layout** edit button. See *Saving and Printing 3D Views on page 1115*.

 Select **Tools> Layout> Referenced Plan Files** to see a list of the files that are referenced by the layout. See *Referenced Plan Files Dialog on page 52*.

### EDITING LAYOUT VIEWS

A selected layout view can be edited much like other box-based objects. See *Editing Box-Based Objects on page 232*. In addition, a variety of edit tools allow you to control the appearance of each view:

 Select a layout view and click the **Open View** edit button to open the view that was originally sent to layout. This tool is only available for dynamic views. See *Editing Dynamic Views on page 1347*.

 Select a layout view and click the **Rescale Layout** edit button to open the Change Scale dialog and apply a different scale. See *Rescaling Views on page 1347*.

 Select a layout view and click the **Relink File** edit button to open the Choose Layout File Reference dialog and relink the selected layout view. See *Relinking Layout Views on page 1354*.

 Select a layout view and click the **Layout Box Layers** edit button to open the Layer Display Options dialog for the selected view. See *Displaying Layout Views on page 1344*.

Note: You can also modify the layers of the layout file itself. See *Layout Page Display Options on page 1334*.

 Select **Tools> Layout> Edit Layout** to allow the lines of a Vector View sent to layout to be edited individually. See *Editing Layout Lines on page 1348*.

### MANAGING LAYOUT PAGES



Layout pages can be managed via the Tools menu as well as using the contextual menu in the Project Browser. See *Layout Page Management on page 1355*.

 Select **Tools> Layout> Edit Page Information** to open the Layout Page Information dialog. See *Layout Page Information on page 1358*.

 Select **Tools> Layout> Insert Page Before** to add a new layout page, moving the current page and all following pages up one page, as long as there is nothing on page 1000. See *Adding and Deleting Pages on page 1356*.



 Select **Tools> Layout> Insert Page After** to add a new layout page, leaving the current page where it is but moving all following pages up one page, as long as there is nothing on page 1000.

Select **Tools> Layout> Duplicate Page** to create an identical copy of the current page immediately after the original and with the same content and Page Information as the original.



-  Select **Tools> Layout> Delete Page** to delete the current layout page, moving all following pages down one page, as long as nothing is on the current page.
-  Select **Tools> Layout> Exchange With Next Page** to switch the current layout page with the following page. Not available on Layout Page 1000.
-  Select **Tools> Layout> Exchange With Previous Page** to switch the current layout page with the page preceding it. Not available on Layout Page 0.



You can also specify the page that an object or group of objects displays on in its specification dialog. See [Line Style Panel on page 305](#).

-  Select **Tools> Layout> Layout Page Table** to place a Layout Page Table. See [Layout Page Tables on page 1361](#).
-  Select **Tools> Layout> Layout Revision Table** to place a Revision Table. See [Revision Tables on page 1361](#).
-  Select **Edit> Delete Objects** to delete categories of objects as well as Page Information from a specified scope of pages in the current layout file. See [Delete Objects Dialog on page 285](#).

## VIEWING LAYOUT FILES

-  Use **Tools> Layout> Page Up, Page Down, and Change Layout Page** to navigate the layout document. See [The Current Page on page 1356](#).
-  Select **Window> Swap Views** to switch between the current view and the view that was current before it. See [Working in Multiple Views on page 150](#).
-  Select **Tools> Layout> Update Layout Views** to access tools that let you update semi-dynamic layout views. See [Keeping Layout Views Current on page 1341](#).



---

## Creating a Layout File

-  To open an existing layout file, select **File> Open Layout**. Browse to a directory and select the layout file to open. See [Opening and Importing Files on page 44](#).

As with plan view windows, when a layout file is open, it is listed at the bottom of the Window menu as an open view. Layout files are also listed in the Project Browser. See [Project Browser on page 58](#).

In order to create a layout file, you must open a new file and then save it.

-  Choose **File> New Layout** to create a blank layout file. A layout file is created with the name **Untitled.layout**. New layout files open to the first regular, non-Template page and use the default and layer settings associated with your layout template. See [Template Files on page 87](#).
-  Select **File> Save** to save the layout file. It is important that you save the layout in the same directory as the plan file from which views will be or have been sent to the layout pages. See [Organizing Your Files on page 36](#).

Although it is possible to use multiple plan files with a layout, it is generally best to associate only one plan file with a layout and to use the same file name for both. If more than one plan file is used, all should be saved in the same directory as the layout file.

When you save your layout, take a moment to also save the plan file associated with it.





When a view is sent to layout, the plan and layout files become linked. If you rename or move either file, this link will be broken and the view will not display. See [Managing Layout Links on page 1353](#).

---

## CAD and Text in Layout



CAD objects, text objects, as well as dimensions can be incorporated into your layout by both including them in your views sent to layout and by drawing them on the layout page.

### ON THE LAYOUT PAGE

CAD and text can be drawn directly on any layout page, allowing you to create a title block, border, as well as notes and other annotations. A variety of Layout Info text macros with information about page number, revisions, and more can be inserted into text objects on layout pages. See [Text Macros on page 540](#).

Layout boxes have labels that can be customized to report a variety of information about each view. See [Layout Box Borders and Labels on page 1345](#).

You can draw dimension lines on the layout page to help position CAD and text objects, as well. Dimensions that locate objects in a view sent to layout, however, should be drawn in the original view. See [Dimensions on page 448](#).

CAD, text, and dimensions created in layout can be selected, edited, and deleted just as they can in other views. See [Editing Text on page 510](#) and [CAD Objects on page 290](#).

Pictures and PDFs can also be imported into layout. See [Pictures, Images, and Walkthroughs on page 1184](#).

To move a text or CAD object to another page, change the **Page** number in its specification dialog. See [Line Style Panel on page 1352](#).

Any text or CAD objects that you would like to display on multiple pages of your layout file - for example, a title block and border - should be drawn on a page specified as a Page Template. See [Layout Page Templates on page 1358](#).

### IN VIEWS SENT TO LAYOUT

CAD, text, and dimensions in views sent to layout are scaled just like other objects in the view. If you want text in a layout view to print at a particular size, specify its size based on the scaling you will use when you send the view to layout. See [Character Size on page 496](#).





If you rotate a view on the layout page, any text in that view will rotate as well, provided that its Text Style is using the **Rotate with Plan** setting. See [Text Styles on page 538](#).

If you wish to use Global Text Macros that provide information about a view, such as its drawing scale or the plan's file name, make sure that the text object is in the view sent to layout - not on the layout page.

A number of macros with information about the layout view can also be added to a layout view's label as Object Specific Macros. See [Layout Box Borders and Labels on page 1345](#).

### CALLOUTS IN PLAN VIEWS

In plan views, callout shapes are used to refer the reader to a different location for more information about a particular feature shown in the view. There are four types of callout, each created in a different way:

- A standard **Callout**  refers to a detail drawing. Callout text can be linked to a particular view or layout page by the user. See *Linked Callouts on page 524*.
- A **Note**  callout is linked to a specific line item in a Note Schedule with written notes on particular topic. See *Notes, Note Types, and Note Schedules on page 533*.
- An object label callout is linked to a **Schedule**  for that particular object type in the plan file. See *The Schedule Tools on page 682*.
- A **Cross Section/Elevation**  callout represents the location of a saved cross section or elevation view in the plan file. By default, these callouts include dynamic information about the location of the view in layout. See *Callout Labels on page 1091*.

---

## Pictures, Metafiles, and PDFs in Layout

Picture files, metafiles, and PDF files can be included in views sent to layout or imported directly onto a layout page. See *Displaying Pictures, Metafiles, and PDF Boxes on page 1200*.

Like CAD and text objects, imported pictures, metafiles, and PDFs can be included on Page Templates. See *Layout Page Templates on page 1358*.

Views can also be sent to layout as pictures embedded in the layout file. See *Static Views on page 1343*.

A picture, metafile, or PDF file imported onto the layout page can be selected and edited using its edit handles, edit tools and specification dialog. See *Editing Pictures, Metafiles, and PDF Boxes on page 1201*.



Embedded pictures and pdf files increase layout file size. Limit the number of large and/or multiple pictures.

---

## Sending Views to Layout

 Layout files can contain many different views and details sent from one or more plan files. Views cannot, however, be sent from one layout file to another. To send the active view from a plan file to layout, select **File> Send to Layout**. Send to Layout is also an option in a selected view's contextual menu in the Project Browser. See *Project Browser on page 58*.

 You can also send one or more saved, closed cross section/elevation views to layout by selecting the camera symbol and clicking the **Send Camera's View to Layout** edit button. This edit tool is only available when the selected view has been saved, has not previously been sent to layout, and is not open. See *Saving and Printing 3D Views on page 1115*.

### To send a view to layout

1. Right-click on one or more selected views in the Project Browser and select **Send to Layout** from the contextual menu. See *Project Browser on page 58*.
2. You can also open a view and select **File> Send to Layout** .
3. In the Send to Layout dialog, select the layout page and other options that you need for the selected view.
4. Click **OK** to send the view to the specified layout page. Depending on the type of view and size of the model, you may see a progress indicator in the Status Bar. See *The Status Bar on page 24*.

## SEND TO LAYOUT DIALOG

The options available in the Send to Layout dialog vary depending on the type of view being sent to layout.

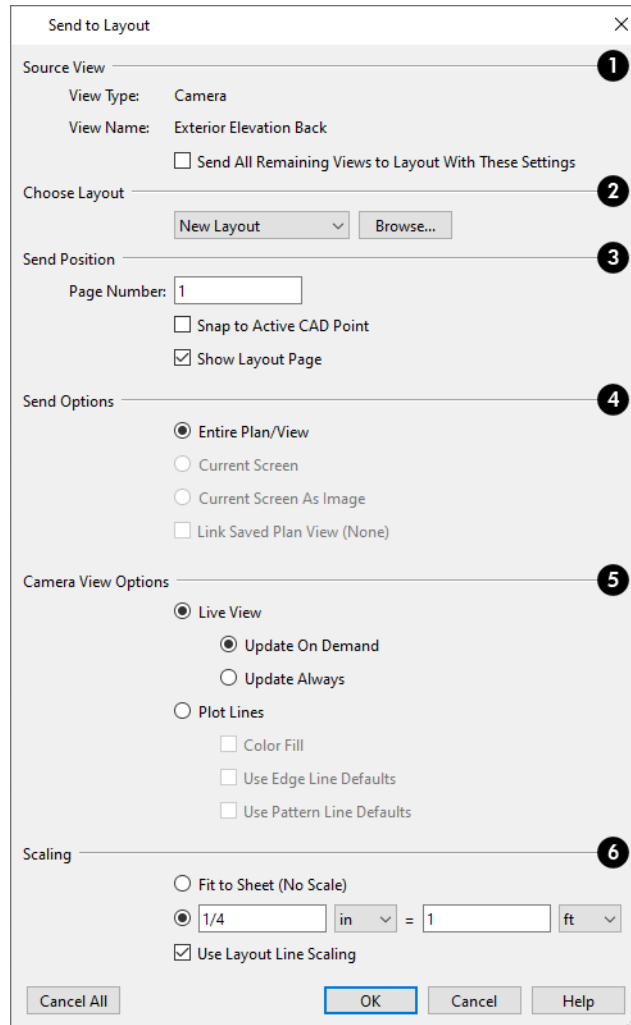

### 1 Source View

- The **View Type** and **View Name** of the view currently being sent to layout are reported here for reference. See *View Windows on page 144*.
- When multiple selected views are being sent to layout, the **Send All Remaining Views to Layout With These Settings** check box will be available. Check this box to send all selected views using the same settings, below when you click OK. When this box is unchecked, an instance of the dialog is presented for each view, allowing you to make any changes you might want.

### 2 Choose Layout

From the drop-down list, select the layout file you would like to send the current view to. All open layout files are available, as is “New Layout”. If the program finds a layout file with the same name as the current plan file, it will be listed as well.

### 3 Send Position

These options are available for all types of views.

- **Send to Layout Page #** - Enter a page number to send the view to.
- Check **Snap to Active CAD Point** to snap the view you are sending to layout to the active CAD Point. See *Point Tools on page 296*.
- Check **Show Layout Page** to go to the selected layout page when you click OK. When this is unchecked, the current view remains active.

#### 4 Send Options

The options available here depend on the type of view being sent to layout. The last settings used for cross section/elevation views are retained during the current program session, as are the last settings used for camera views and overviews, and those used for plan and CAD Detail views.

- Select **Entire Plan/View** to send to layout the extent of the plan that is visible when you click **Fill Window** . This option is not available for Perspective 3D views. See *Types of 3D Views on page 1080*.
- Select **Current Screen** to send only what is shown on screen to layout. This option is available for all view types.
- Select **Current Screen As Image** to send only what is shown on screen to layout as an embedded image. See *Picture File Box Specification Dialog on page 1193*. This option is available for all views, and is the only option available for rendered and CPU Ray Trace views.
- When **Link Saved Plan View** is checked, the view being sent to layout is dynamically linked to the Saved Plan View currently in use. The name of that view is stated in parentheses for reference. Uncheck this box to use the current floor, layer set, Reference Floor settings, and the currently active Default Set, but not the Saved Plan View. Not available if the view being sent to layout is not a Saved Plan View. The Saved Plan View can also be specified in the view's Layout Box Specification dialog. See *Layout Box Specification Dialog on page 1349*.

#### 5 Camera View Options

These options are available for cross section/elevation, camera views, and overviews sent to layout - provided that **Current Screen as Image** is not selected, above. The last settings used for cross section/elevation views are retained during the current program session, as are the last settings used for camera views and overviews.

- Select **Live View** to make the view dynamically linked to the plan file.
- Select **Update on Demand** to update the view only when prompted. See *Keeping Layout Views Current on page 1341*.
- Select **Always Update** to update the view any time a change is made to the model. This option ensures that the view is always current but may cause program slowness.

- Select **Plot Lines** to send a Vector View to layout that uses automatically generated Plot Lines to represent surface edges and material pattern lines in the model. See [Plot Line Views on page 1343](#).
- Check **Color Fill** to include colors that correspond to the materials used in the model.
- Check **Use Edge Line Defaults** to use the line weight and color set in the view's Layout Box Specification dialog for all object edge lines, including those using Below Grade setting overrides. See [Linked View Panel on page 1350](#) and [Below Grade Panel on page 1127](#).  
When unchecked, the view uses layer- and/or object-specific settings, per the **Surface Edge Lines** settings in the 3D View Defaults dialog. See [3D View Defaults Dialog on page 1083](#).
- Check **Use Pattern Line Defaults** to use the line weight and color set in the view's Layout Box Specification dialog for all material pattern lines. See [Linked View Panel on page 1350](#).  
When unchecked, the pattern line weight and color settings set in the Define Material dialog are used. See [Pattern Panel on page 1067](#).

 The Edge and Pattern Line Defaults settings are included for legacy files and are not the recommended method of specifying this information. See [Edge and Pattern Lines on page 178](#).

## 6 Scaling

Select a radio button to specify how the view sent to layout is subjected to scaling.

- Select **Fit to Sheet (No Scale)** to send the view to layout at approximately half the size of the layout drawing sheet. Once on the layout page, the view can be resized.
- Specify the **exact scale** for the view in layout. The view can be rescaled later from layout if necessary. Both U.S. and metric units of measurement are available and can be selected independently.
- When views are sent to layout at different scales, line weights and line styles are subject to the same scaling. In most cases this is not desirable. When **Use Layout Line Scaling** is checked, the lines in views sent to layout appear the same as lines drawn directly on layout. This option is not available for rendered views. See [Line Weights and Scaling on page 1375](#).

---

## Keeping Layout Views Current

It is not uncommon for changes to be made to a plan after views have been sent to layout. In order to make sure that your layout file is up-to-date, it is important to recognize that there are four types of layout views:

- [Dynamic Views on page 1341](#), which update automatically every time changes are made to the original view in the plan.
- [Semi-Dynamic Views on page 1343](#), which fully update when printed or prompted by you.
- [Static Views on page 1343](#), which do not reference the plan and cannot be updated: only replaced.
- [Plot Line Views on page 1343](#) have elements that are Dynamic or Semi-Dynamic and others that are Static.



Semi-Dynamic and Plot Line Views can be updated using the **Update Layout View** tools. Select **Tools> Layout> Update Layout Views**. In addition, a selected view can be updated using the **Update View**  edit tool.

### DYNAMIC VIEWS

Dynamic views reference the original view in the plan and update automatically whenever changes are made to that view, including:

- Changes to the model.
- Changes to annotations in the view.
- Changes to the layer set used by the layout view. See [Layout View Layer Sets on page 1344](#).
- Changes to the settings of any of the **Active Defaults**  in use in the view.
- Changes to any of the Saved Plan Default Specification settings.





In order for a view to be Dynamic, it must be sent to layout using either the **Entire Plan/View** or **Current View** Send Option. In addition, camera views must have **Update Always** specified. See [Send To Layout Dialog on page 1339](#).

While convenient, Dynamic views require use of your computer's resources and may slow program performance. This is particularly the case with GPU Ray Trace views. Consider sending cameras, overviews, and cross section/elevations to layout as Semi-Dynamic views.



## SAVED AND UNSAVED PLAN VIEWS

For the most part, plan views sent to layout are Dynamic; however, a number of elements are Static unless they are modified in the Saved Plan View they are associated with, and that view is then saved. See [Plan Views on page 146](#).

These elements are also Static if the layout view links to an unsaved plan view. When this is the case, however, most of them can be specified in the Layout Box Specification dialog. See [Layout Box Specification Dialog on page 1349](#).

- The default **Display in Plan View** and **Display of Openings in Non-Displayed Parts of Walls** settings for pony walls are saved with each Saved Plan View and are a permanent part of the layout view unless the Saved Plan View is saved after the settings are modified. See [Pony Wall Defaults on page 345](#).
- The floor level shown in a view sent to layout does not change if you move to a different floor in the plan. See [Multiple Floors on page 730](#).
- The **Reference Display**  setting in a view sent to layout is unaffected if the Reference Display is turned on or off in the plan. See [The Reference Display on page 738](#).
- The **Color**  setting in a view sent to layout is unaffected if Color is toggled on or off in the original view. See [Color On/Off on page 191](#).
- The **Active Defaults**  that are in use when a plan view is sent to layout are not affected when you switch to different defaults in the plan. See [Using Active Defaults on page 84](#).
- The layer set used by a layout view does not change if you switch layer sets in the plan. See [Layer Sets on page 182](#).
- In all cases, the **Rotate Plan View**  angle is a permanent part of the layout view. In order to modify this angle in a view sent to layout, you must delete the view from the layout page and resend it. See [Rotate Plan View on page 147](#).

There are several ways to specify whether a plan view sent to layout links to a Saved Plan View or not:

- Make active the Saved Plan View or an unsaved view prior to sending it to layout.
- Specify the desired Saved Plan View or choose "None" in the Layout Box Specification dialog.
- Select a layout view or views and click the **Create Saved Plan View**  edit button. If a Saved Plan View with the same attributes as the selected view already exists, you will be given a choice to link to it or to create a duplicate in the plan file. If one does not exist, you can create a new one and specify its name.
- Select a layout view or views and click the **Unlink Saved Plan View**  edit button.

For information about controlling the display of dynamic views in layout, see [Displaying Layout Views on page 1344](#).

## SEMI-DYNAMIC VIEWS

Camera views, overviews, and cross section/elevation views can all be sent to layout as Semi-Dynamic views. Semi-Dynamic views reference the original view in the plan but no information about the model or the view's layer settings update unless you prompt the layout view to update.

When a cross section/elevation view has been sent to layout, CAD objects, text, and dimensions in that view are fully Dynamic - even if the view is set to **Update on Demand**. See *Detailing Cross Section/Elevation Views on page 1094*.

In order for a view to be Semi-Dynamic, it must be sent using either the **Entire Plan/View** or **Current View** Send Option and have **Update on Demand** specified. See *Send To Layout Dialog on page 1339*.

There are several ways to update a Semi-Dynamic view:

- Select it and click the **Update View**  edit button;
- Select **Tools> Layout> Update Layout Views> Update All Views** ; or
- Select **Tools> Layout> Update Layout Views> Update All Live Views** .
- Update on Demand views also update automatically when you print the layout page that they are on.

Views set to **Update on Demand** may experience a loss in quality as you zoom and pan on the layout page. To restore a view's resolution, simply update it.

Note: When GPU Ray Trace views are updated on the layout page, 20 samples are run and the view is then denoised. When these layout views are printed, however, they use the Maximum Export Samples set via the camera's specification dialog and are only denoised if Denoise When Complete is checked. See *Camera Panel on page 1117*.

## STATIC VIEWS

Static views are like a snapshot of the model taken at a specific time: they do not update when the plan changes. If changes to the plan need to be shown in a Static view, that view must be deleted and resent to layout.

All views sent to layout using the **Current Screen as Image** option are Static. They are treated as imported images embedded in the layout file. See *Picture File Box Specification Dialog on page 1193*.



Because CPU Ray Trace views are themselves static images of the model, **Current Screen as Image** is the only option available when sending one to layout. See *CPU Ray Tracing on page 1167*.

## PLOT LINE VIEWS

Camera views, overviews, and cross section/elevation views using the Vector View Rendering Technique can be sent to layout as Plot Lines. See *Rendered and Vector Views on page 1080*.

In Plot Line views, the lines in the layout view that represent the 3D model are automatically generated copies of those in the original view, allowing them to maintain the line weights that were specified in the plan. See *Line Weights on page 1374*.

- Plot Line views are Semi-Dynamic in that they are linked to the original view and can be updated.
- Plot Line views are Static in that they will not update automatically when printed: they can only be updated manually by you.

- The Plot Lines themselves are also Static: they can be edited using the **Edit Layout Lines**  tool, but if the view is updated, these lines are deleted and replaced. For this reason, you should only use the **Edit Layout Lines**  tool after the model has been finalized. See [Editing Layout Lines on page 1348](#).
- Any CAD objects, text, or dimensions drawn in a cross section/elevation view sent to layout will not be copied and represented by Plot Lines. These objects are fully Dynamic and will update immediately in the layout view if changes are made to them. See [Detailing Cross Section/Elevation Views on page 1094](#).
- The **Color**  setting in a Plot Line view is unaffected if Color is toggled on or off in the original view in the plan. See [Color On/Off on page 191](#).
- Image objects are not included in Plot Line views. See [Images on page 1185](#).

Plot Line views do not automatically update when printed, nor can they be set to update automatically. In order to update a Plot Line view, you must do one of the following:

- Select it and click the **Update View**  edit button;
- Select **Tools> Layout> Update Layout Views> Update All Views** ; or
- Select **Tools> Layout> Update Layout Views> Update All Plot Line Views** .

---

## Displaying Layout Views



Just as some elements in a view window do not print, they are not included when a view is sent to layout: for example, the Reference Grid and camera symbols in plan view. See [Print Preview on page 1371](#).

 Although camera symbols are not included in views sent to layout, camera callouts are when the “Cameras” layer is turned on in the view. See [Camera Labels and Callouts on page 1098](#).

### LAYOUT VIEW LAYER SETS

When a view is sent to layout, the active layer set is used. See [Sending Views to Layout on page 1338](#).

Whether or not the layer settings in a view can be edited after it has been sent to layout depends on the view’s type. See [Keeping Layout Views Current on page 1341](#).

- The layer set used by a Dynamic or Semi-Dynamic view can be modified using the **Layout Box Layers**  edit tool.
- A different layer set can also be selected for Dynamic and Semi-Dynamic views using the **Layout Box Layers**  edit tool.
- In addition, Dynamic and Semi-Dynamic views’ layer settings can be modified by opening the original view. See [Opening Layout Views on page 1353](#).
- Static views cannot be changed. Similarly, even in Dynamic views, some features are static and cannot be altered.

The layer set referenced by a Dynamic layout view is saved with the plan rather than the layout file.

 Do not delete layer sets that are used in layouts.



### ***To use the Layout Box Layers tool***

1. Select a layout view.
2. Click the **Layout Box Layers**  edit button to open the Layer Display Options dialog for the selected view. See [Layer Display Options Dialog on page 179](#).
  - If this edit button is not available, the view is not dynamic.
  - The layer set for the layout view displays at the top of the dialog.
  - The settings for the currently selected layer display below.
3. You can make changes to settings of the current layer set.

Changes made to this layer set affect all other views that use it, not necessarily the selected layout view alone.

4. Alternatively, you can select a different layer set for the layout view from the **Layer Set** drop-down list.
5. Be sure to **Save**  your changes in the plan file before closing the layout.

### **LAYOUT BOX BORDERS AND LABELS**

A border will display around each layout box when the “Layout Box Borders” layer is set to display in the Layout Page Display Options dialog. See [Layout Page Display Options on page 1334](#).

Layout boxes can also display labels when the “Layout Box Labels” layer is set to display. See [Label Panel on page 700](#).

Automatic layout box labels display basic information about the original view in the plan. For example, plan view sent to layout from Floor 1 will have an automatic label that says, “1st Floor”. A camera view sent to layout will have a label that states the camera’s name. Layout box labels have their own edit handles and can be customized to include text as well as Object Specific Text Macros. See [Text Macros on page 540](#).

Layout box labels can also be set to use callouts and markers. A callout or marker label can report its current page and the name of the view, and can be linked to a different view or layout page and report information about it, as well. See [Linked Callouts on page 524](#).

### **MISSING LAYOUT VIEWS**

If a view on the layout page can be selected but cannot be seen, its link to the plan from which it was sent may have been broken. See [Managing Layout Links on page 1353](#).

---

## **Editing Layout Views**

To edit a layout view, first select its layout box using the **Select Objects**  tool. Once selected, the view box can be edited using its edit handles, edit toolbar or specification dialog.

### **USING THE EDIT HANDLES**

Layout view boxes can be edited using their edit handles like closed polyline-based objects. See [Editing Closed Polyline-Based Objects on page 228](#).

## IN THE SPECIFICATION DIALOG

Layout view boxes can be customized in their specification dialog. See *Layout Box Specification Dialog on page 1349*.

## USING THE EDIT TOOLS

A selected layout view or views can be edited in a variety of ways using the buttons on the Edit Toolbar. See *The Edit Toolbar on page 130*.

A few edit tools are unique to layout boxes:



**Rescale Layout View** allows you to specify the selected view's scale. See *Rescaling Views on page 1347*.



**Relink File** lets you change the plan file that a dynamic view is linked to. See *Relinking Layout Views on page 1354*.



**Create Saved Plan View** allows you to associate a selected layout view or views to a Saved Plan View in the plan that it is linked to. If a Saved Plan View with attributes identical to the selected view(s) exists, you will be asked to choose to link to it or create a new Saved Plan View. See *Plan Views on page 146*.



**Unlink Saved Plan View** disassociates the selected layout view(s) from a Saved Plan View and instead lets you specify the floor level and Default Set that the view shows. See *Layout Box Specification Dialog on page 1349*.



**Layout Box Layers** specifies which layer set and layer settings the selected view uses. See *Layout Page Display Options on page 1334*.



**Pan/Scale Layout Box** allows you to click and drag to pan within the selected view as well as specify its scale using inline text fields. See *Panning the Display on page 154*.



**Recenter Layout Box Contents** centers the contents of the view in the layout box without changing the view's scale.



**Scale Layout Box Contents to Fit** rescales the view so that all contents can be seen within the layout box's current extents.

## USING DIMENSIONS

Like other CAD based objects, layout views can be moved and resized using dimensions. See *Moving Objects Using Dimensions on page 483*.

## MOVING VIEWS TO A DIFFERENT PAGE

To move a view from one layout page to another, select the view, click the **Open Object**  edit button, and change the **Page** on the LINE STYLE panel of the Layout Box Specification dialog. See *Layout Box Specification Dialog on page 1349*.

## COPYING VIEWS

Just like many objects, views sent to layout can be copied and pasted onto different layout pages or even into different layout files.

As a general rule, though, if multiple copies of a view are needed, it is best to send the view to layout as many times as necessary because each view can then be controlled independently.

Bear in mind, too, that if a layout has views copied from a different layout file and is later moved to a different location on your computer, the link to the original plan file may be broken. See *Keeping Layout Views Current on page 1341*.

## EDITING DYNAMIC VIEWS

Select a Dynamic or Semi-Dynamic view and click the **Open View**  edit button to open the original view that was sent to layout. You can also double-click a view of either type in layout to open the original view. See [Opening Layout Views on page 1353](#).

## RESIZING SCALED VIEW BOXES

Scaled views retain their scale regardless of how you resize the border. If the border is increased in size, blank spaces may be created; if the border is made smaller, the view may become cropped.

## RESIZING NON-SCALED VIEW BOXES

If the view was sent to layout using the **Fit to Sheet** setting, or if a view is set to **No Scale** in the Change Scale dialog, resizing may have one of two results:

- Drag a corner edit handle using the **Alternate**  Edit Behavior to resize both the border and the image proportionally. See [Alternate on page 207](#).
- If you use any other Edit Behavior or if you drag a side edit handle, the perimeter of the layout box changes but the view inside it stays the same size. If you make the border smaller, the view may become cropped.

## RESCALING VIEWS

There are a couple of ways to rescale a floor plan, CAD Detail, or cross section/elevation view sent to layout:



The **Pan/Scale Layout Box** edit tool allows you to change the scale of a selected layout view box by typing the desired scale in a pair of inline text fields.



**Scale Layout Box Contents to Fit** rescales the view so that all contents can be seen within the layout box's current extents. The program chooses a scale that best achieves this task, regardless of whether it is a commonly used scale or not.



The **Rescale Layout View** edit tool opens the Change Scale dialog.

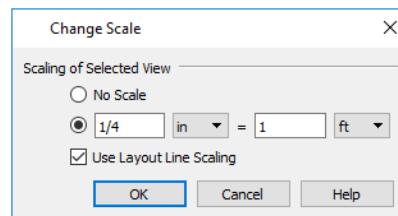

- Choose **No Scale** to remove any specific scale factor associated with the selected view.
- Select the second option to specify a scale for the view. When its scale is changed, the layout view will resize. In most cases, you should specify a scale for plan views, CAD Details, and cross sections/elevation views. Typical scales are  $\frac{1}{4}$  in = 1 ft and 1 m = 50 m.
- When a view is sent to layout at a scale other than that of the original view, line weights and line styles are affected. In many cases, this is not desirable. Check **Use Layout Line Scaling** to make lines in the selected view appear the same as lines of the same weight drawn on the layout page. See [Line Weights and Scaling on page 1375](#).

## Editing Layout Lines

 Individual object edge and material pattern lines in a Vector View sent to layout using the Plot Lines option can be selected, edited, and drawn using the **Edit Layout Lines** tool. Changes made using this tool have no effect on the 3D model. See *Rendered and Vector Views on page 1080*.

Bear in mind that automatically generated Plot Lines are not dynamically linked to the model: if the layout view is updated, these lines are deleted and replaced. For this reason, you should only use the **Edit Layout Lines** tool after the model has been finalized. See *Keeping Layout Views Current on page 1341*.



The full set of CAD editing tools is not available when using Edit Layout Lines. It is often more efficient to edit lines in a Vector View by sending it to a CAD Detail for editing first. See *CAD Detail from View on page 338*.

CAD lines drawn in cross section/elevation views sent to layout cannot be edited using the **Edit Layout Lines** tool. Only Plot Lines generated by the program can be edited using this tool. See *CAD and Text in Layout on page 1337*.

### SELECTING LAYOUT LINES



To select a line in a layout view, click the **Edit Layout Lines** button and click on the line. You can select additional lines in the same layout view using the marquee select or group select methods. See *Selecting Objects on page 210*.

### ADDING NEW LAYOUT LINES

Add a line to a layout Vector View by clicking the **Edit Layout Lines** button, selecting a layout view, and drawing a new line within the layout box. Once drawn, this line can be edited like any other layout line and maintains its position in relation to the layout view it was drawn in.

### EDITING LAYOUT LINES

When a layout line is selected, you can use the edit handles to change its size, angle, and position, as with standard CAD lines. A selected layout line can also be deleted like a standard CAD line; however, many of the edit tools that are available for standard CAD objects are not available for layout lines.

**Angle Snaps** , **Object Snaps** , and **Grid Snaps** are all available in layout. See *Snap Settings on page 158*.

Layout line properties can be changed in the Layout Line Specification dialog.

### LAYOUT LINE SPECIFICATION DIALOG

 Use the **Edit Layout Lines** tool to select one or more lines in a Vector View sent to layout, then click the **Open Object** edit button to open the Layout Line Specification dialog.

The dialog lets you change the properties of the selected line(s) without changing the properties of all lines in the view.

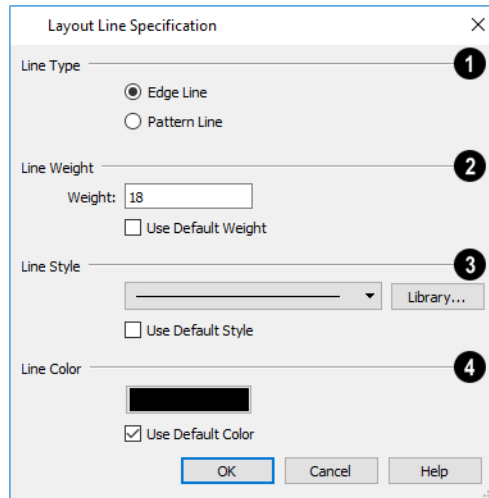

### 1 Line Type

- Select **Edge Line** to specify the selected line(s) as defining the edges of the surface of 3D objects.
- Select **Pattern Line** to specify the selected line(s) as patterns lines for materials such as brick, siding, and shingles.
- When multiple lines are selected, **No Change** may be available.

### 2 Line Weight

See [Line Weights on page 1374](#).

- Type the desired Weight, or thickness, of the selected line(s) in the text field.
- Check **Use Default Weight** to use the default value set in the view's Layout Box Specification dialog. See [Linked View Panel on page 1350](#).

### 3 Line Style

See [Line Styles on page 199](#).

- Select a line style from the drop-down list or click the **Library** button and choose one from the Library.
- Check **Use Default Style** to use the default style set in the Layout Box Specification dialog.

### 4 Line Color

- Click the **Color** bar to select a line color. See [Color Chooser/Select Color Dialog on page 203](#).
- Check **Use Default Color** to use the default color set in the Layout Box Specification dialog.

---

## Layout Box Specification Dialog

 Select one or more layout view boxes and click the **Open Object** edit button to open the Layout Box Specification dialog. The settings that are available will depend on the types of views selected.

The settings on the LINE STYLE, FILL STYLE, and LABEL panels of this dialog are similar to those in the LAYOUT BOX DEFAULTS dialog. See [Layout Preferences and Defaults on page 1334](#).

## LINKED VIEW PANEL

The settings on the LINKED VIEW panel vary depending on the type of view selected. See *Dynamic Views on page 1341*.

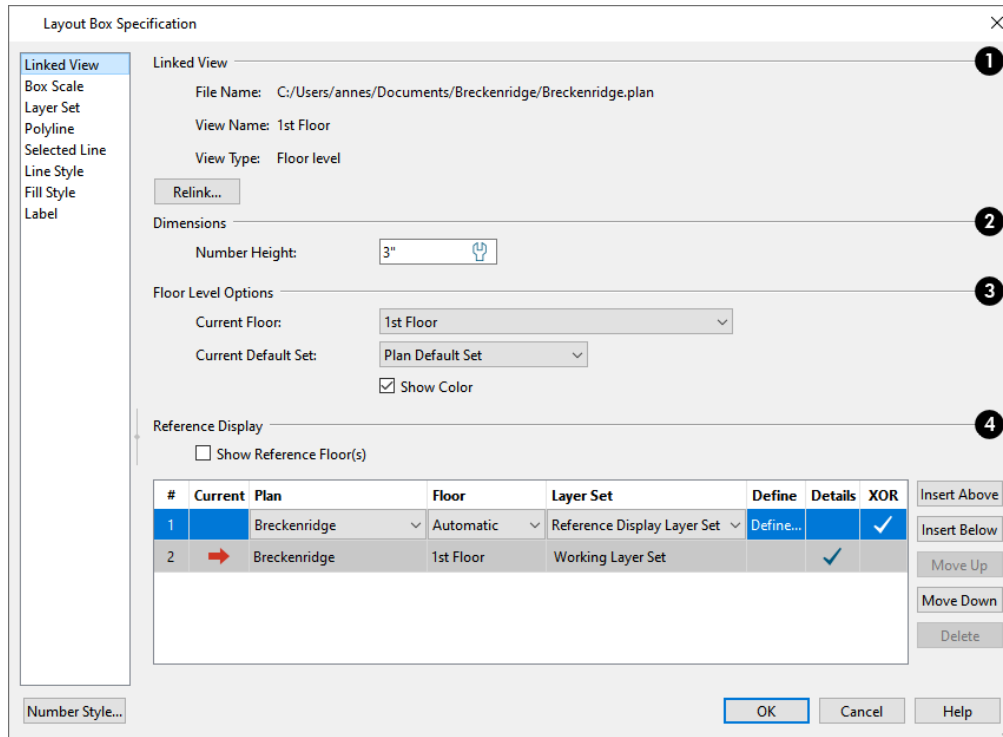

### 1 Linked View

Information about the view that the selected layout box is linked to is reported here. If the selected layout box is not linked to a view, these lines will be blank.

- **File Name** reports the linked file's full pathname.
- **View Name** reports the name of a saved view; the floor level is reported for unsaved plan views. See *View Windows on page 144*.
- **View Type** reports the view's Type. A plan view is referred to as "Floor level" if unsaved. See *Saved Views on page 144*.
- Click the **Relink** button to open the Link View dialog. See *Link View Dialog on page 51*.

### 2 Dimensions

The **Number Height** setting is only available in legacy layout files when the selected view is using a non-default Number Height value. This legacy setting affects the size of dimension numbers in the selected layout view but not in the original plan file. See *Dimension Defaults Dialog on page 451*.

### 3 Options

These settings vary, depending on the type of view selected.

The **Saved Plan View Options** are only available when the Linked View is a saved plan view. See *Plan Views on page 146*.

- The **Current Floor** is reported here for reference only.
- Click the **Edit View** button to open the view's specification dialog. See *Plan View Specification Dialog on page 148*.

The **Floor Level Options** are only available when the Linked View is a plan view that is not saved. See *Plan Views on page 146*.

- Specify the **Current Floor** level shown in the view. See *Displaying Floor Levels on page 734*.
- Select the **Current Default Set** used in the view from the drop-down list. See *Default Sets on page 83*.
- Uncheck **Show Color** to turn color off in the selected view. See *Color On/Off on page 191*.

The **Camera View Options** are only available when the Linked View is a cross section/elevation view, camera view, or overview. See *3D View Tools on page 1084*.

- Select **Live View** to make the view dynamically linked to the plan file.
- Select **Update on Demand** to update the view only when prompted. See *Keeping Layout Views Current on page 1341*.
- Select **Always Update** to update the view any time a change is made to the model. This option ensures that the view is always current but may cause program slowness.
- Select **Plot Lines** to make the view a semi-dynamic Vector View with automatically generated plot lines that represent surface edges and material pattern lines. See *Plot Line Views on page 1343*.
- Check **Color Fill** to include colors that correspond to the materials used in the model.
- Specify the **Line Weight** and **Line Color** defaults for edge lines and pattern lines in the current Plot Lines view. See *Line Styles on page 199*.

The **Edge Line Defaults** and **Pattern Line Defaults** settings are only available when Plot Lines is selected above, and only have an effect on the entire view if Use Edge Line Defaults and/or Use Pattern Line Defaults were checked when the view was originally sent to layout. These settings are also the defaults for lines modified using the **Edit Layout Lines**  tool. See *Send To Layout Dialog on page 1339* and *Editing Layout Lines on page 1348*.

#### **4 Reference Display**

These settings are only available when the Linked View is an unsaved plan view, and control the display and appearance of the Reference Floor in that view. These settings are only active when the Linked Saved Plan View is “None”, above, and are also found in the Change Floor/Reference dialog. See *The Reference Display on page 738*.

#### **BOX SCALE PANEL**

The settings on the BOX SCALE panel control how the contents of the selected layout box are scaled. See *Printing to Scale on page 1372*.

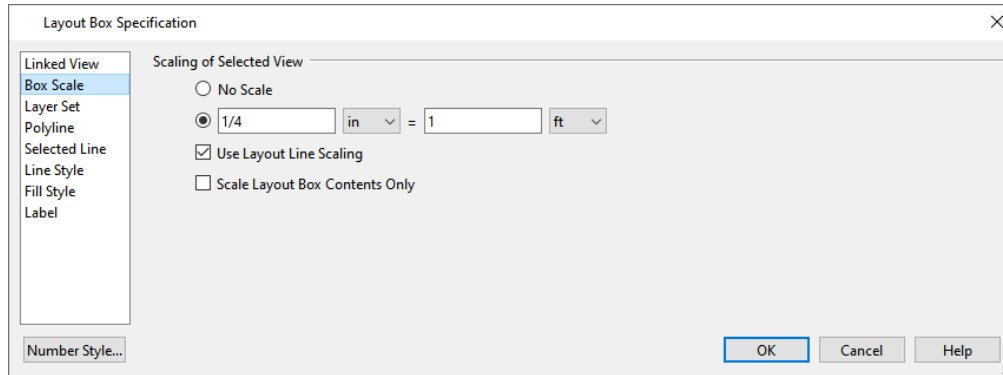

- Choose **No Scale** to remove any specific scale factor associated with the selected view
- Select the second option to specify a scale for the view. When its scale is changed, the layout view will resize. In most cases, you should specify a scale for plan views, CAD Details, and cross sections/elevation views. Typical scales are  $\frac{1}{4}$  in = 1 ft and 1 m = 50 m.
- When a view is sent to layout at a scale other than that of the original view, line weights and line styles are affected. In many cases, this is not desirable. Check **Use Layout Line Scaling** to make lines in the selected view appear the same as lines of the same weight drawn on the layout page. See [Line Weights and Scaling on page 1375](#).
- When **Scale Layout Box Contents Only** is checked and you change the scale of the selected view, the layout box will resize to match. When unchecked, the layout box will remain the same size.

## LAYER SET PANEL

The LAYER SET panel has one setting: select the view's **Active Layer Set** from the drop-down list. This option is only available when the selected layout box is linked to a view that is not saved. See [Layer Sets on page 182](#).

## POLYLINE PANEL

The POLYLINE panel states the length of the countertop's **Perimeter**, its **Area**, and its **Volume**. See [Polyline Panel on page 317](#).

## SELECTED LINE/ARC PANEL

The SELECTED LINE panel is available when the selected edge is a line as opposed to an arc. For more information, see [Line Panel on page 304](#).

The SELECTED ARC panel is available when the selected edge has been converted to an arc. For more information, see [Arc Panel on page 312](#).

See, too, [Selected Edge on page 212](#) and [Change Line/Arc on page 256](#).

## LINE STYLE PANEL

The settings on the LINE STYLE panel let you set the properties of the selected layout box's border and to specify what layout page it is located on.

For more information, see [Line Style Panel on page 305](#).



## FILL STYLE PANEL

For information about the FILL STYLE panel, see [Fill Style Panel and Dialogs on page 193](#).



## LABEL PANEL

Layout box labels display in layout when the “Layout Box Labels” layer is turned on and use the Text Style assigned to that layer. See [Layout Box Borders and Labels on page 1345](#).

For more information about the settings on this panel, see [Label Panel on page 700](#).

---

# Opening Layout Views

 Dynamic and Semi-Dynamic views sent to layout refer to an original view in a plan. From the layout page, you can access that original view by selecting a layout box, then clicking the **Open View** edit button. The original view can also be opened by double-clicking the layout view using the **Select Objects**  tool.

Changes made in this view update in the original layout view. Be aware that depending on the changes you make, other views may also be affected.

## LAYER SETS

Notice the name of the current layer set that at the top of the Active Layer Display Options side window. Changes made to this layer set affect not only the current view, but also the associated layout view and any other views that use this layer set. See [Layer Sets on page 182](#).



It is important to remember that when a plan view is accessed by opening a dynamic layout view, that view uses the same layer set as the layout view.

## DEFAULT SETS

Plan views, cross section/elevation views, and CAD Details sent to layout each have a set of Active Defaults associated with it. When you send one of these view types to layout, these defaults become associated with the layout view; and when you open the original view of one of these types of layout views, its defaults will become active automatically. See [Multiple Saved Defaults on page 79](#).

You can specify which defaults are associated with a plan view sent to layout by specifying the view’s **Current Default Set** in the Layout Box Specification dialog See [Layout Box Specification Dialog on page 1349](#).

Note that the Current Default Set associated with a layout view always uses the layer set assigned to the layout view, regardless of how the Default Set itself may be defined.

---

# Managing Layout Links

Chief Architect allows you to review the plan files linked to a current layout, change existing links from one plan file to another, and reestablish links to plan files that have been moved or renamed.

## PROTECTING LAYOUT LINKS

Careful file management is needed to avoid missing files and disrupted layout links. See *Organizing Your Files on page 36*.

The following guidelines can help prevent layout links from being broken:

- Save plan files in the same folder as the layout, or in a sub-folder in that folder.
- Custom graphics included in a plan or layout should be embedded in the file or saved in the same folder as the layout.
- Plan files used to save CAD details or other information should be copied and saved in the same folder as the layout.
- Plan files should never be renamed. If a new name is desired, make a copy of the file and rename the copy. Changes made in the copy do not affect views sent to layout from the original plan.
- Avoid sending cross section/elevations to layout more than once. Changes made to the view can affect layout views in unintended ways.
- Layout files should never be moved. If a layout file must be moved, the entire folder it is saved in should be moved or copied and then moved.
- Use **File> Backup Entire Layout**  to create an independent copy of the original layout. Avoid use of “Save As.” See *Backup Entire Plan or Layout on page 55*.
- Do not delete any layer sets that are used by a view that was sent to layout. See *Layer Sets on page 182*.
- If you relink a layout view to a new plan, be sure to save the plan file so the layer sets are updated.

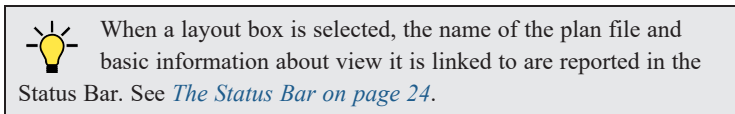

## FINDING MISSING FILES

When a layout file is opened, the program performs a breadth-first search for dynamically linked views. This means that it:

- Looks first in the same folder as the layout.
- Looks next in the folders located closest to the layout’s folder.
- If a missing file is not found, it expands its search further from the location of the layout file until the files with the linked views are located.
- If a missing file is not found, a second breadth-first search will be performed, searching all zipped files found in the first search.

If a file remains missing after the program performs a search of your system, a Warning message will indicate that the program could not successfully open all of the layout’s associated plan files. When you click OK, the Referenced Plan Files dialog will open, allowing you to relink the layout to its missing associated files.

You can also open this dialog at any time by selecting **Tools> Layout> Referenced Plan Files**  while a layout file is open.

## RELINKING LAYOUT VIEWS



There are a couple of ways to relink a dynamic layout view to a different view. One way is to select it and click the **Relink Layout Box** edit button to open the Link View dialog. See *Link View Dialog on page 51*

You can also relink a layout box to a view in the Layout Box Specification dialog. See *Linked View Panel on page 1350*.

If you want to relink all references to a particular plan file so they refer to equivalent views in a different plan, use the Referenced Plan Files dialog. See *Referenced Plan Files Dialog on page 52*.

## MISSING LAYER SETS

The layer set associated with each view in a layout is saved with the plan file from which the view was sent. Just as it is important to not move, rename, or delete the plan file, it is important that you not rename or delete a layer set used by a layout view.

If a layer set used by a layout view cannot be found when the layout is opened, the Missing Layer Set dialog will display.

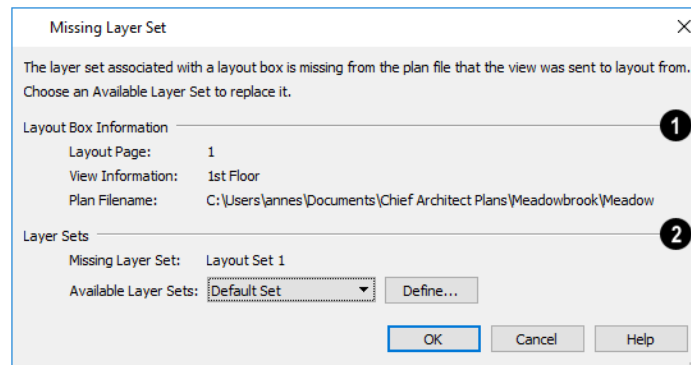

### 1 Layout Box Information

The **Layout Box Information** describes the layout view that is missing a layer set, indicating:

- The **Layout Page** where the view in question is located;
- View Information, which describes the contents of the view in question,
- The **Plan Filename** of the plan file that the layer set is missing from.

### 2 Layer Sets

The **Layer Sets** options allow you to replace the missing layer set.

- The name of the **Missing Layer Set** displays for reference.
- Select a replacement layer set from the **Available Layer Sets** drop-down list.
- Click the **Define** button to open the Layout Page Display Options dialog, where you can make changes to the selected layer set.

---

## Layout Page Management

Layout files are organized into separate pages numbered 0 through 1000. There are a variety of tools that let you navigate and organize the pages of a layout file.

### IN THE PROJECT BROWSER

All pages in a layout file that are in use are listed in the Project Browser, including Page Templates and all pages with content and/or Page Information. See *Project Browser on page 58*.

Typically, blank layout pages are not listed in the Project Browser; however, if a new page is inserted using the contextual menu in the Project Browser, that new, blank page will be listed.

The three types of pages can be distinguished by the icon to the left of their names:

 **Page Template**

 **Page with Content**

 **Blank Page**

The contextual menu for a layout page in the Project Browser allows you to view it, edit its Layout Page information, move it relative to other pages, or delete it. See [Contextual Menus on page 19](#).

Pages are listed in order of their page number. You can change a page's number, and thus its location in the layout file, by clicking and dragging it in the Project Browser. See [Project Browser on page 58](#).

## THE CURRENT PAGE

 The current layout page is indicated at the center of the Layout Page Up/Down buttons. When a layout file is first created, the current page is page one.

The current layout page is the default target of any view sent to layout. If sent to the wrong page, a view may be moved from one page to another. To do this, select the view you want to move, then click the **Open Object**  edit button to open the Layout Box Specification dialog. You can change the page number on the LINE STYLE panel. See [Layout Box Specification Dialog on page 1349](#).

### To navigate between layout pages

1. Click the arrow buttons on either side of the **Layout Page** button.
2. Click the **Current Page number** between the arrows to open the Go To Layout Page dialog. Enter a page number and click **OK**.

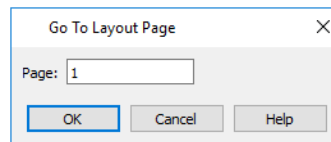



3. Select **Page Up** or **Page Down** from the **Tools> Layout>** menu.
4. Press Shift + N (up one page) or Shift + M (down one page) on the keyboard.
5. Double-click on a page in the Project Browser.

Note: Layout pages do not print if they are blank, even if a border and title block are present.

## ADDING AND DELETING PAGES

To begin work on a new page, simply send a view to that page, or navigate to it and begin drawing.

  To insert a layout page in front of or behind the current page, select **Tools> Layout> Insert Page Before** or **Insert Page After**. Any pages that follow the new page move up one, provided that nothing is located on page 1000.

You can also right-click on a page in the Project Browser and select either **Insert Page Before** or **Insert Page After** from the contextual menu.

To create an identical copy of the current page with the same content and Page Information as the original, select **Tools> Layout> Duplicate Page**. A duplicate is added immediately after the original and is active. You can also right-click on a page in the Project Browser and select Duplicate from the contextual menu.

 To remove the current page from the layout file, select **Tools> Layout> Delete Page**. The current page and all information on it - including any views - will be completely removed. You can also right-click on a layout page in the Project Browser and select **Delete Page**.

Page Templates assigned to other pages cannot be deleted, and neither can page zero. See *Layout Page Zero on page 1358*.

### EXCHANGING PAGES

 Select **Tools> Layout> Exchange With Next Page** to switch the current layout page with the following page. Not available on Layout Page 1000.

 Select **Tools> Layout> Exchange With Previous Page** to switch the current layout page with the page preceding it. Not available on Layout Page 0.

### LAYOUT PAGE INFORMATION

 The **Edit Page Information** tool lets you specify any layout page as a Page Template or add information about it which can then be included in layout and revision tables. See *Layout Page Information on page 1358*.

### LAYOUT PAGE NUMBERING

Each layout page has a number from 0 through 1000 which is used to identify its position in the layout document.

While this basic numbering convention cannot be changed, you can create your own page numbering convention using the **Label** setting in the Layout Page Information dialog. See *Layout Page Information on page 1358*.

To do this, begin by typing a prefix of your choice followed by a pound (#) sign in the **Label** field - for example, "A-#". The program will replace the # with a numeral 1 on the first page with that particular prefix in its Label, and will increase the number by one on every page that follows if it too has the identical prefix in its Label.

Although you can specify a Label for your page Templates, regular pages do not inherit this information from their specified Template: it must be added to each page individually.

Custom page numbering using the Layout Page Label can be added to any page - including Page Templates - by inserting the %layout.label% macro into a text object. See *Text Macros on page 540*.

There is also a selection of additional text macros that can be used to insert dynamic page numbering information:

Macro	Result
%page%	Layout Page Number - States the absolute page number of the current layout page.
%page.print%	Printed Page Number - States the printed page number of the current page. Blank pages are not included in this count.

Macro	Result
<b>%numpages%</b>	Number of Printed Pages - States the total number of printed pages in the layout.
<b>%lastpage%</b>	Last Used Layout Page - States the absolute page number of the last printed page.

## LAYOUT PAGE TEMPLATES

Layout Page Templates allow you to create a title block and border in one place and then assign them for use on any other layout pages that you wish. Multiple Page Templates can be created in the same layout file. Note that if a layout page is specified as a Page Template, it will not print as part of a print range. Page Templates can be printed as the Current Sheet, however. See *Print View Dialog on page 1380*.

Add anything to a Page Template that you want on some or all of your printed layout pages, such as:

- Title Block. See *Text, Callouts, and Markers on page 493*.
- Borders. See *CAD Objects on page 290*.
- Text Macros. See *Text Macros on page 540*.
- Imported images. See *Images on page 1185*.

Note: The printable area varies from printer to printer. For best results, inset layout borders 1/2" to 3/4" from the paper edge.

You can assign a Page Template to any layout page, or specify any page as a Page Template, in the Layout Page Information dialog. See *Layout Page Information on page 1358*.

## LAYOUT PAGE ZERO

In Chief Architect X5 and prior, Layout Page Zero was the only available Page Template. In Version X15, it functions in much the same way by default: it is specified as a Page Template with the title “Default Page Template”, and it is assigned to all pages.

Because of its special purpose, Layout Page Zero cannot be deleted.

# Layout Page Information



The **Edit Page Information** tool opens the Layout Page Information dialog, which you can use to add title, revision, and other information to the current layout page. This information can then be used to create layout and revision tables, as well as used in text macros.

You can also use this tool to specify the current page as a Template, or to assign a Template to the current page. See *Layout Page Templates on page 1358*.

The Layout Page Information dialog can be opened in several ways:

- Select **Tools> Layout> Edit Page Information**.
- Click the **Edit Page Information** toolbar button.
- Right-click on a layout page in the Project Browser and select **Edit Page Information** from the contextual menu.

## LAYOUT PAGE INFORMATION DIALOG

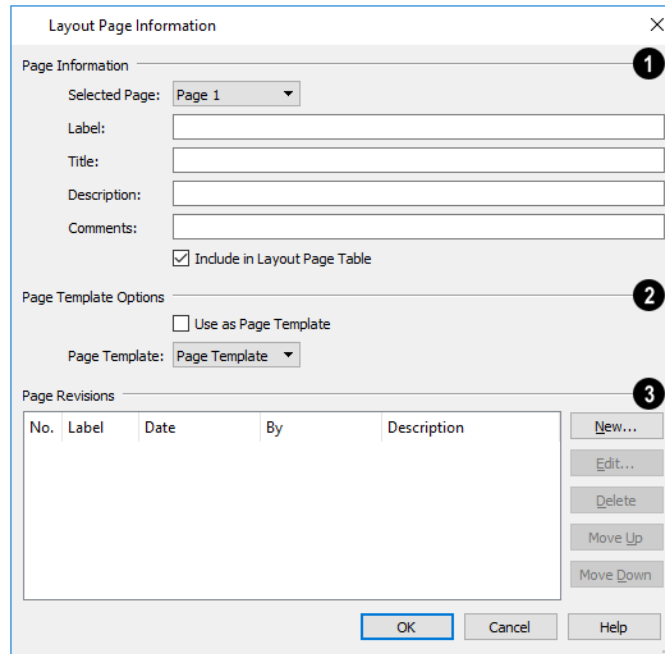

### 1 Page Information

The **Page Information** options let you add information to layout pages that can be shown in a Layout Page Table or added to text using a macro. The Label and Title will also display in the Project Browser.

- Choose the **Selected Page**, which is the page selected for editing in this dialog, from the drop-down list. Not available when the dialog is opened via the Project Browser contextual menu.
- Specify the selected page's **Label**. If a cross section/elevation view is sent to this layout page, this Label can display in the camera's callout label in plan view. See *Camera Labels and Callouts on page 1098*.

 If you type a pound sign # in the Label field, it will be replaced by the current layout page number on the layout sheet. See *Layout Page Numbering on page 1357*.

- Specify the selected page's **Title**.
- Specify the selected page's **Description**.
- Specify the selected page's **Comments**.
- Check **Include in Layout Table** to include the above information about the selected page in a Layout Table. If Use as Page Template is checked, this box will be unchecked automatically.

### 2 Page Template Options

The **Page Template Options** let you associate the selected layout page with a template, or specify it as a template. See *Layout Page Templates on page 1358*.

- Check **Use as Page Template** to specify the selected page as a template that can be assigned to other pages, but not printed. This box cannot be unchecked if the current page is the Page Template assigned to other pages.

- Assign a **Page Template** to the selected page by choosing one from the drop-down list. Not available when Use as Page Template is checked.

### 3 Page Revisions

The **Page Revisions** settings let you manage the revisions associated with the selected page. Revisions can be shown in a Revision Table or added to text using a macro. See *Revision Tables on page 1361*.

- A table listing any revisions associated with the selected page displays for reference. Click on a line item in the table to select it.
- Click the **New** button to open the Layout Revision Specification dialog and add a new revision to the selected page.
- Click the **Edit** button to open the Layout Revision Specification dialog and edit the selected revision.
- Click the **Delete** button to remove the selected revision from the table.
- Click the **Move Up** or **Move Down** button to adjust the position of the selected revision in the table accordingly.

## REVISION SPECIFICATION DIALOG

 Select **Tools > Layout > Add Layout Revision** to open the Revision Specification dialog. You can also click the **New** or **Edit** button in the Layout Page Information dialog to open this dialog.

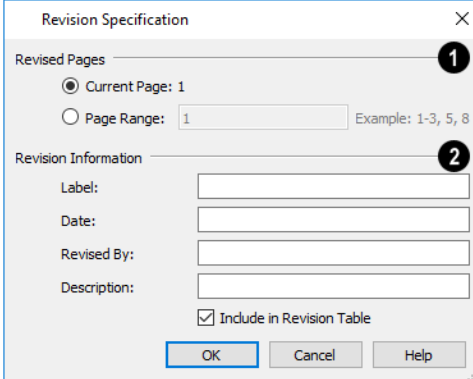

### 1 Revised Pages

Specify which pages the selected revision applies to. Only available when a new revision is being created.

### 2 Revision Information

- Specify the revision's **Label**.
- Specify the **Date** that the revision was made. The program populates this field with the current date automatically.
- Specify who the revision was **Revised By**. The program populates this field with your Designer Information by default. See *Designer/Client Information on page 541*.
- Specify a **Description** of the revision.
- Check **Include in Revision Table** to include this revision in a Layout Table for the selected page.



---

## Layout Page and Revision Tables

Title, revision, and other information can be added to each layout page and used to create tables of contents and revision schedules.

Layout Tables are similar to schedules and can be edited much the same way that schedules can. See [Editing Schedules on page 685](#).

### LAYOUT PAGE TABLES

 Select **Tools> Layout> Layout Page Table**, then click on a layout page to place a Layout Page Table at that location. Layout Page Tables list all pages in the current file that have Layout Page Information specified, are set to be included in Layout Page Tables, and have data on them. See [Layout Page Information on page 1358](#).

If you place a Layout Page Table on a Page Template, it will display on every page in the current layout that uses that template and will list all pages that have data and are set to be included in Layout Page Tables.

### REVISION TABLES

 Select **Tools> Layout> Layout Revision Table**, then click on a layout page to place a Layout Revision Table at that location. Layout Revision Tables list all revisions associated with the current page.

Unlike Layout Page Tables, Layout Revision Tables are page-specific. If you place a Layout Revision Table on a Page Template, it will display on every page that uses that template, but it will only list revisions associated with the current page. See [Layout Page Templates on page 1358](#).

---

## Printing Layout Files

 Printing layout files is similar to printing a view in a plan file. Select **File> Print> Print** to open the Print dialog. See [Print View Dialog on page 1380](#).

As in plan views, printing options for layouts are set in the Drawing Sheet Setup dialog. These options apply to all pages of the layout file. See [Drawing Sheet Setup Dialog on page 1367](#).

If a page does not have any data on it, it will not print. Only pages with one or more views sent to them or Text, CAD, or Dimensions drawn on them are printed.

Pages specified as Page Templates do not print unless the template is the current page and you specifically choose the **Current Page** Print Range option. See [Print View Dialog on page 1380](#).

Physically-Based Ray Trace renderings sent as live views to layout are printed after 20 samples at 96 dpi. If a layout file has one or more live Physically Based Ray Trace views sent to it, additional time to print may be required. See [Physically Based \(Ray Trace\) on page 1151](#).

### PRINTING TO SCALE

A layout file's drawing scale is specified in the Drawing Sheet Setup dialog. While you can specify any drawing scale that you wish, in nearly all circumstances, you will want the scale to be **1 in = 1 in** or **1 mm = 1 mm** for all layout files.

The views sent to your layout pages have already been assigned a scale, and if you select a scale other than one-to-one for the layout, these views will be scaled a second time when printed.



Layout views will print at their specified scales only when the drawing scale for the layout file is 1 in = 1 in or 1 mm = 1 mm.

To see or change the current scale of a layout view, select the view and click the **Rescale Layout View**  edit button. See [Rescaling Views on page 1347](#).

When a view is sent to layout at a scale other than that used by the original view, line weights may be affected. See [Line Weights and Scaling on page 1375](#).

## PRINTING SERVICES

If you plan to use a printing service, you may want to install a PDF writer. See [Printing to a PDF File on page 1374](#).

You can also print to file using the driver for the printer that the service will use. See [Printing to File on page 1365](#).

Find out what paper size the print service uses and select it in the Drawing Sheet Setup dialog. See [Drawing Sheet Setup Dialog on page 1367](#).

## CHECK PLOTS

When a large drawing sheet size has been specified, you can print a check plot at a reduced scale so that it can be printed on a smaller printer. This allows you to make final checks before printing to the larger size. See [Check Plots on page 1373](#).

---

# Exporting Layout Files



Layout pages can be exported to **.dxf/.dwg** files much like any other vector-based view.

The main difference is in the scale of the output, which is in scaled paper units rather than model units. If a 50" line in a plan would be scaled to 1" inch when printed, it is exported as a 1" line instead of its length before prior to scaling. See [Exporting 2D DXF/DWG Files on page 1235](#).

# Printing and Plotting

## Chapter 42

Chief Architect provides a variety of options for printing scaled plan views, cross section/elevation views, and 3D perspectives.

To create working drawings, you can use the program’s Layout facility. Multiple views of the model can be arranged on pages along with a border and title block. For more information, see *Layout on page 1333*.

Chief Architect also allows you to save your drawings in **.pdf** file format that can then be sent to a printing service.

Note: Screen captures are provided for illustrative purposes only and are not an endorsement of any products.

### TOPICS

<b>Introduction to Printing</b> .....	<b>1364</b>
<b>Printers and Plotters</b> .....	<b>1364</b>
<b>Printing Defaults</b> .....	<b>1365</b>
<b>The Printing Tools</b> .....	<b>1366</b>
<b>Drawing Sheet Setup Dialog</b> .....	<b>1367</b>
<b>Print Preview</b> .....	<b>1371</b>
<b>Printing to Scale</b> .....	<b>1372</b>
<b>Printing Across Multiple Pages</b> .....	<b>1374</b>
<b>Printing to a PDF File</b> .....	<b>1374</b>
<b>Line Weights</b> .....	<b>1374</b>
<b>Watermarks</b> .....	<b>1377</b>
<b>Print View Dialog</b> .....	<b>1380</b>
<b>Print Image Dialog</b> .....	<b>1383</b>

---

## Introduction to Printing

Chief Architect Premier offers printing options to suit a variety of needs. It is helpful to be familiar with these options and choose the one that makes the most sense for the project at hand.

Note: Student, Academic, and Presentation versions of the software produce a non-editable watermark on all printed documents.

### OUTPUT OPTIONS

**Printing From Layout** - For professional quality documents with a title block, border, and multiple views of the model, printing from layout provides the best results. For more information, see [Layout on page 1333](#).

**Printing Directly From a View** - You may prefer to print individual drawings directly from a view. See [Print Tools on page 1367](#).

**Printing to PDF** - Plans can be printed to a .pdf file and printed remotely. See [Printing to a PDF File on page 1374](#).

**Export to STL** - Exports an .stl file that can be printed on a stereolithography machine, or 3D printer. See [STL Format on page 1005](#).

### TERMINOLOGY

**Drawing Sheet Size** - The dimensions of the final printed output. This may or may not be the same as the printer paper size. If the sheet and paper sizes are the same, only one page is required per sheet. See [Drawing Sheet Setup Dialog on page 1367](#).

**Paper Size** - The dimensions of the paper to be printed on. Specifying a paper size that is smaller than the Sheet Size allows large drawings to be printed across multiple pages.

**Check Plot** - A test printing, typically at a smaller scale, made before final output to large paper format. For more information, see [Check Plots on page 1373](#).

**Line Weight** - The thickness of a line. A thicker line weight is easier to see, but may not show as much detail. See [Line Weights on page 1374](#).

**Drawing Scale** - You can specify this scale in the Drawing Sheet Setup dialog. See [Drawing Sheet Setup Dialog on page 1367](#).

When a particular scale is not important, drawings can also be sized to fill a particular area. See [Printing to Scale on page 1372](#).

 Always familiarize yourself with your printer or plotter before a deadline is near, and bear in mind that it can take a little time to configure a new printer.

---

## Printers and Plotters

There are many different types of printers and plotters. In general, a printer is smaller, normally outputting 8½ x 11" (Letter or ANSI A size), 8½ x 14" (Legal Size) or sometimes as large as 11 x 17" (Tabloid or ANSI B size).

Plotters are typically used to output larger sheets of paper such as 17 x 22" (ANSI C), or 18" x 24" (ARCH C).

## PRINTER DRIVERS

A printer driver is a program that allows a printer to communicate with the rest of the computer system. Drivers are usually created by the printer manufacturer, are typically updated regularly, and can usually be downloaded free of charge from the manufacturer's website.

In addition to interpreting between the printer and the rest of the system, printer drivers save default page size, orientation, margin size, and other information that Chief Architect refers to unless you specify otherwise. See [Print View Settings on page 1366](#).

If you experience printing problems, consider installing updated drivers for your printer. Visit your printer manufacturer's website for more information.

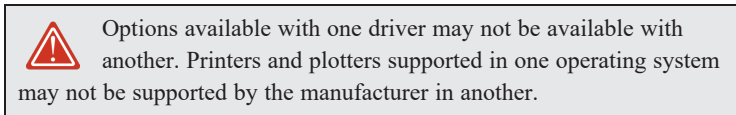

## PRINTING TO FILE

If your print service requires you to print to a file that can be read by their plotter, you can install that printer's drivers on your system and then use the Windows System Print dialog to Print to File. See [Print View Dialog on page 1380](#).

Printing to a file is not an option in the Mac System Print dialog.

## CLEARING PRINTER INFORMATION

Some information specific to individual printers, such as available paper sizes, is saved with each plan file. You can select **File> Print> Clear Printer Info** to clear the printer-specific information stored with the plan file.

---

# Printing Defaults

You can print to any printer or plotter that is supported on your operating system and can specify the current printer at any time in either the Drawing Sheet Setup or Print View dialog.

## DRAWING SHEET SETUP

 When any orthographic view is active, you can specify its Drawing Sheet size, margins, orientation, printed Drawing Scale, and more in the Drawing Sheet Setup dialog. Select **File> Print> Drawing Sheet Setup** to open this dialog. See [Drawing Sheet Setup Dialog on page 1367](#).

The settings in the Drawing Sheet Setup dialog are view-specific. This means that in a plan file, they can be set up one way for plan views and a different way for each cross section/elevation view and CAD Detail. When a new view is created, its initial settings are derived from the current plan view settings.

The Drawing Scale set in the Drawing Sheet Setup dialog acts as the default scale for the active view's Print, Printed Size Input, and Send to Layout dialogs. See [Send To Layout Dialog on page 1339](#).

The settings in the Drawing Sheet Setup dialog can be customized and saved in your template plans and layout files. See [Template Files on page 87](#).

## PRINT VIEW SETTINGS



When you are ready to print an orthographic view, select **File> Print> Print**. The initial settings in the Print View dialog are drawn from the Drawing Sheet Setup for the view. The system's default printer is selected and if possible, the paper size and orientation are set to match those of the Drawing Sheet.

Once a view has been printed, most of the settings in the Print View dialog are saved and will be applied to all views of the same type, in all Chief Architect Premier files. View types with separate Print View settings are:

- Plan view
- Cross Section/Elevation views
- Layout
- Materials Lists
- CAD Details
- Time Tracker Logs

If you prefer that the Print View settings not be retained in this manner, uncheck **Remember Print Settings after Printing** in the Drawing Sheet Setup dialog.

## DISPLAYING OBJECTS



You can control the display of objects when printing directly from a view in the Layer Display Options dialog. See [Layer Display Options Dialog on page 179](#).

Objects must be visible in order for them to print; however, not all items that are visible will print. See [Print Preview on page 1371](#).

To control the display of objects in an orthogonal view sent to layout, select the view, click the **Layout Box Layers**  edit button, and make any needed changes in the Layer Display Options dialog. See [Layout View Layer Sets on page 1344](#).

To control the display of objects in a camera view sent to layout, turn layers on/off in the view before it is sent to layout. You may find it helpful to create a custom layer set for printing directly from a view. See [Layer Sets on page 182](#).

## PRINT PREVIEW



To get a sense of whether your current settings will meet your needs when printed, you can use the **Print Preview** toggle to view the printed output on screen before any paper is used. See [Print Preview on page 1371](#).

---

# The Printing Tools



Select **File> Print** to view the Print Tools submenu. These tools fall into four categories.

## PRINT SETUP TOOLS



**Drawing Sheet Setup** - Opens the Drawing Sheet Setup dialog. See [Drawing Sheet Setup Dialog on page 1367](#).



**Scale to Fit** - Automatically selects a scale that fits your plan to the drawing sheet. See [Printing to Scale on page 1372](#).



**Center Sheet** - Automatically centers the drawing sheet on your drawing. See [Center Sheet on page 1372](#).



**Print Preview** - Shows on screen how the current view will appear printed, based on the current scale and other settings. See [Print Preview on page 1371](#).

## PRINT TOOLS



**Print** - Prints the current plan view, Vector View, CAD Detail, or layout sheet to a specified scale. See [Print View Dialog on page 1380](#).



**Print Image** - Prints the current view including images, textures, and backdrop. Views printed with Print Image are not scaled. See [Print Image Dialog on page 1383](#).



You can also select **File> Export> Export PDF** to open the Export PDF dialog. See [Print View Dialog on page 1380](#).

## DISPLAY TOGGLES

A number of toggles allow you to turn various aspects of the display on or off. See [Interface Toggles on page 13](#).



**Color** - Turn the on-screen display of color on or off in all views except perspective views. See [Color on page 1371](#).



**Line Weights** - When this is on, line weights appear on screen as they will print. See [Line Weights on page 1371](#).



**Drawing Sheet** - Turn this on for a preview of your plan relative to the current Drawing Sheet. See [Drawing Sheet on page 1371](#).



**Reference Grid** - The Reference Grid does not print, so you can turn this off to get a better sense of what the view will look like printed. See [Reference Grid on page 1371](#).

## ADDITIONAL PRINT TOOLS

**Customize Sheet Sizes** - Allows you to create custom sheet sizes. See [Customize Sheet Sizes Dialog on page 1370](#).

**Clear Printer Info** - Some information specific to individual printers, such as available paper sizes, is saved with each file. This clears the printer-specific information associated with the current page setup.

---

# Drawing Sheet Setup Dialog



The settings in the Drawing Sheet Setup dialog control the sheet size and scaling for the current view. Select **File> Print> Drawing Sheet Setup** to open this dialog.

The Drawing Sheet Setup dialog is only available when a plan view, cross section/elevation view, CAD Detail, or layout is active. When a perspective view is active, **Drawing Sheet Setup** is not available.

The settings in this dialog are specific to the current view and are saved with the .plan or .layout file. See [Printing Defaults on page 1365](#).

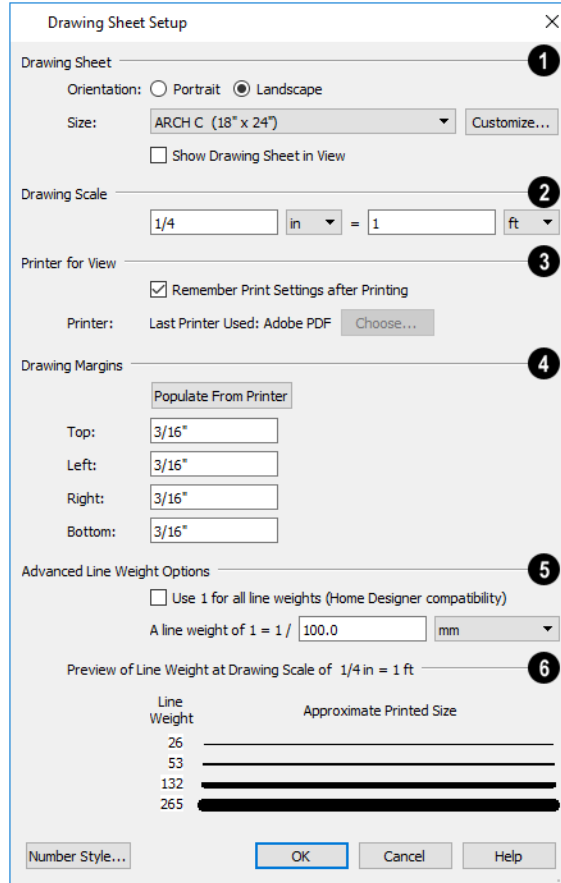

### 1 Drawing Sheet

Specify the **Orientation** and **Size** of the **Drawing Sheet**, which is the final printed output.

- Click the **Customize** button to open the Customize Sheet Sizes dialog. See *Customize Sheet Sizes Dialog on page 1370*.



Paper can often be inserted into plotters in either of two orientations. Refer to your plotter's documentation to find out which way to insert the paper for correct results.

- Check **Show Drawing Sheet in View** to turn on the display of the Drawing Sheet in orthographic views. See *Drawing Sheet on page 1371*.

### 2 Drawing Scale

Specify the **Drawing Scale** for the active view. This scale is applied only when the view is printed.

The scale is specified in two parts, which by default are 1 ft = 1 ft or 1 m = 1 m for layout views, and ¼ inch = 1 ft or 1 m = 50 m for all other views. Both U.S. and metric units of measurement are available and can be selected independently. The units of measurement available here can be controlled in the Preferences dialog. See *Unit Conversions Panel on page 109*.

The **Drawing Scale** acts as the default scale for the active view's Print, Print Size Calculator, and Send to Layout dialogs.

### 3 Printer for View

Specify the **Printer for View** which is the printer for the active view in the current file. These settings are global, affecting



all plan and layout files.

- Uncheck **Remember Print Settings after Printing** to enable the Choose button, below. When this is checked, the printer is selected in the Print View dialog. See *Printing Defaults on page 1365*.
- Click the **Choose** button to select a printer and edit its paper settings in the Default Printer for View dialog.

The **name** of a **Printer** displays to the left of the Choose button for reference.

- If the **Remember** box is checked, the last printer used in the current view type is shown; if no printer has been used in the current view, “None” will display.
- If the **Remember** box is unchecked, the system’s default printer will be shown.

If you have questions about your printer’s settings, consult its documentation.

#### 4 Drawing Margins

Specify the **Drawing Margins** which define the extents of the printable area of the active view’s Drawing Sheet.

- Click the **Populate from Printer** button to set the margins based on the selected printer’s default settings. See *Printers and Plotters on page 1364*.
- Specify the width of the **Top**, **Bottom**, **Left**, and **Right** margins.

#### 5 Advanced Line Weights

The **Advanced Line Weight Options** allow you to specify the active view’s line weight scale. A layout file’s line weight scale should always be the same as that of any plan views associated with it. See *Line Weights and Scaling on page 1375*.

- Check **Use 1 for all line weights (Home Designer compatibility)** to have the program maintain a consistent line thickness and dash size when the drawing scale is changed. When checked, the Line Weight Scale is based on a 1/4 inch = 1 foot drawing scale and 1= 1/300 inch line weight scale. Plans originally created in any of the Home Designer programs have this checked by default; however, this option is not available for layouts and is not normally recommended. See *Line Weights on page 1374*.
- Select the **Line Weight Scale**. See *Line Weights and Scaling on page 1375*. This setting should always be the same for both a given layout file and any plan views associated with it.

#### 6 Preview of Line Weight

A line weight **Preview** illustrates how changes to the line weight scale affect the printed size of various line weights at the current Drawing Scale.

### DEFAULT PRINTER FOR VIEW DIALOG

To open the Default Printer for View dialog, click the **Choose** button in the Drawing Sheet Setup dialog.

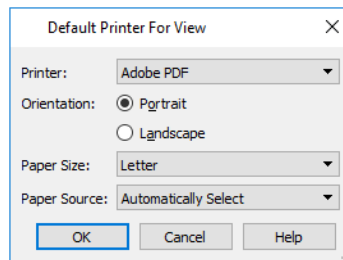

- Select a **Printer** from the drop-down list.
- Choose the **Orientation** of the paper used by the selected printer.
- Select a **Paper Size** from the drop-down list. The options available will depend on the selected printer.
- Select a **Paper Source** from the drop-down list. The options available will depend on the selected printer.

## CUSTOMIZE SHEET SIZES DIALOG

To open the Customize Sheet Sizes dialog, select **File> Print> Customize Sheet Sizes**, or click the **Customize** button in the Drawing Sheet Setup dialog.

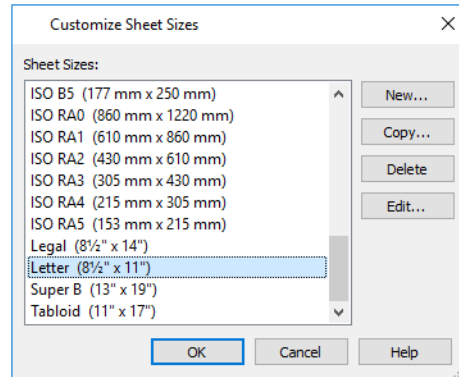

Several options are available:

- Click **New** to create a new sheet size.
- Select a sheet size and click **Copy** to create a duplicate sheet size.
- Click **Delete** to remove the selected sheet size.
- Select a sheet size and click **Edit** to open the Edit Paper Size dialog and change its description, dimensions, and units of measurement.

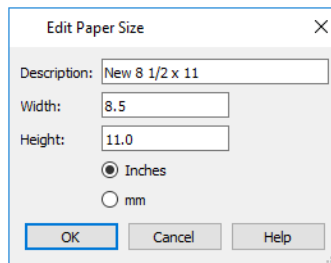

- Click **OK** to close the dialog. Any new sheet sizes created are now available in the Drawing Sheet Setup dialog.
- The data for this dialog is stored in the “sheetSizes.sheet” file in the program’s Data folder.

## CLEARING PRINTER INFORMATION

Select **File> Print> Clear Printer Info** to clear the printer-specific information stored in the Drawing Sheet Setup dialog. See *Printers and Plotters on page 1364*.

This is useful for creating plan and layout templates without an associated printer. See *Template Files on page 87*.



## Print Preview

Print Preview and its related display toggles allow you to get a sense of what the current view will look like when it is printed.

### PRINT PREVIEW



Select **File> Print> Print Preview** for an on-screen representation of how the current view will appear when printed. Print Preview is only available in views that can be scaled. See [Printing to Scale on page 1372](#).

When **Print Preview** is on, the Drawing Sheet and line weights are displayed, and the **Drawing Sheet**  and **Line Weights**  toggles are overridden.

Objects such as camera symbols, CAD points, text and dimension objects appear on-screen as they will on the printed page.

When **Print Preview**  is enabled, color will display depending on whether **Print in Color** is selected in the Print View dialog. See [Print View Dialog on page 1380](#).

The Reference Display does print if it is visible. See [The Reference Display on page 738](#).

### COLOR



The **Color** toggle turns the on-screen display of color on or off in all views. When Color is toggled off, views print in either black and white or grayscale depending on your **Preferences** setting. See [Colors Panel on page 98](#).

### REFERENCE GRID



The **Reference Grid** is an on-screen grid composed of regular squares that can be used to convey a sense of scale while drawing. It does not print, and its size can be specified in the General Plan Defaults dialog. See [General Plan Defaults Dialog on page 92](#).

### LINE WEIGHTS



Select **View> Line Weights** for an on-screen representation of line weights and line styles. Turning **Line Weights** on or off does not affect the final printed output.

- When **Line Weights** is turned on, you can **Zoom In**  to see the location of lines and dashed lines as they will appear on the printed page.
- When **Line Weights** is off, dashed lines look the same, regardless of the zoom factor.

**Line Weights** can also be turned on or off in the Preferences dialog. See [Appearance Panel on page 95](#).

### DRAWING SHEET



The Drawing Sheet is a representation of the size and orientation of the final printed output. It is different from the printed page size, which means that you can print a large Sheet to multiple smaller pages. Select **View> Drawing Sheet** to show the Drawing Sheet on screen.

The Drawing Sheet size and orientation are specified in the Drawing Sheet Setup dialog. See [Drawing Sheet Setup Dialog on page 1367](#).

When the Drawing Sheet is set to display, a blue border representing the margins of the printable area will also display for reference. If the margins have been set to populate from the selected printer, this border may not display on all edges of the drawing sheet. See *Printer Drivers on page 1365*.

When **Drawing Sheet**  is on, the drawing sheet behaves as an object.

- When selected at its border the sheet has edit handles, allowing it to be moved. See *Editing Objects on page 205*.
- You can also resize the sheet using its edit handles; however, for best results, it is recommended that you instead select an available sheet size in the Drawing Sheet Setup dialog. See *Drawing Sheet Setup Dialog on page 1367*.
- Dimension lines can locate the edges of the sheet and can be used to position other objects relative to it. See *Moving Objects Using Dimensions on page 483*.



Note: Specifying a sheet size in the Drawing Sheet Setup dialog is preferable to editing the sheet size on-screen.

The drawing sheet cannot be rotated or copied.

## CENTER SHEET



Select **File> Print> Center Sheet** to center the drawing sheet on the drawing. This moves the sheet relative to the drawing but does not affect the coordinates of objects in the drawing. The location of the drawing sheet is independent for each floor of the model.

---

# Printing to Scale

Several different print scaling options are available. The type of view that you are printing determines which options you may choose from.

## ORTHOGONAL VIEWS

Plan views, Orthographic 3D views, CAD Details, and layout pages are orthogonal views, which means:

- Your line of sight is at a right angle to all objects in the view.
- Objects do not appear to decrease in size as their distances from the viewer increase.

Orthogonal views can be printed to scale; however, Orthographic 3D views can only be printed to scale when the Vector View Rendering Technique is used.

The scale set in the Page Setup dialog is inherited by the Print and Send to Layout dialogs. This scale can be overridden on an individual basis in either of these dialogs. See *Print View Dialog on page 1380* and *Sending Views to Layout on page 1338*.

Select **File> Print> Scale to Fit**  in an orthogonal view to select a suitable scale and re-center the drawing sheet so that everything fits on the sheet.

U.S. Unit drawing scales are typically noted in inches per foot. Larger scales, such as 1 inch = 50 feet or 1:200m, are often used for property layouts.

Once a view has been sent to layout, there are a variety of additional scaling options. See *Rescaling Views on page 1347*.

## PERSPECTIVE VIEWS

Camera views and Perspective overviews display the model much the way the eye would see it and cannot be scaled.

- Objects in the view may be at any angle relative to your line of sight.
- Objects seem to decrease in size as their distances from the viewer increase.

Perspective views can only be printed using the **Print Image**  tool. See *Print Image Dialog on page 1383*.

While perspective views cannot be scaled, you can control the printed size of the view. If **Fit to Paper** is selected in the Print View dialog, a percent value can be set that defines how much of the printed page to fill. See *Print View Dialog on page 1380*. 50% causes the print to be 50% of both the height and width of the paper, including the non-printable border.

For example, if printing to an 8½ x 11 page with a 1" non-printable border in each direction:

- 100% would print an area 8½ x 11. This is not recommended, as part of the output could fall outside the printable area.
- 50% would print an area 4¼ x 5½.
- Each printer may vary slightly.

## CHECK PLOTS

A check plot is a test print that allows you to print at a reduced scale on smaller, less expensive paper so you can check that the drawing will print as expected. The drawing scale is temporarily adjusted to a specified fraction of its true value. Both drawing scale and line weights are subject to this scale adjustment.

For example, if a layout has a border designed to fit on a Drawing Sheet of 24" x 36", a check plot at 1/2 scale would allow it to fit on a 12" x 18' page. A view sent to that layout at a Drawing Scale of 1/4" = 1' would be scaled at 1/8" = 1' when printed at 1/2 scale.

### *To create a check plot*

1. Select **File> Print> Print View** . In the Print View dialog:
  - Click the **Check Plot at** radio button, then choose the desired scale fraction from the drop-down list.
  - The **Paper Size** will automatically adjust to fit the selected Check Plot Scale.
  - Confirm that the **Paper Size** is the size you wish to use, then click **Print**.
2. The next time you print a view, remember to choose **To Scale** or **Fit to Paper** again in the Print View dialog.

## PRINTING TEXT, DIMENSIONS, AND LINE STYLES

As with other objects your drawings, text and dimension numbers are subject to scaling when views are sent to layout or printed. See *Scaling Text on page 513*.

Printed text size is also influenced by the selected font and the method used to specify its size. See *Character Size on page 496*.

Text may not print exactly as it appears on-screen. To get a better idea of how text and dimension characters will print, you may find it helpful to **Zoom In**  on them.

For best printed results, using true-type or open-type fonts is recommended.



Text may not appear accurately on screen when the font used by the printer is different from the font used on screen. Consult your printer documentation for more information on font substitution.



The line styles assigned to CAD and a variety of other objects are subject to scaling when printed as well. They are only subject to scaling when sent to layout, however, under specific circumstances. See *Line Weights and Scaling on page 1375*.

---

## Printing Across Multiple Pages

When printing directly from a plan view, cross section/elevation view, or layout it is possible to print at a scale that does not fit the drawing on one page.

When printing to a paper size that is smaller than the sheet size, a 2% overlap is used. Crop marks print where the paper needs to be cut between pages. A solid line is drawn at the drawing sheet boundary on the sides that need to be cut.

To see on-screen what the drawing will look like when printed, select **View> Drawing Sheet**  and then **Window> Fill Window** . Grey lines across the drawing sheet indicate where the page breaks will occur. See [Drawing Sheet on page 1371](#).

---

## Printing to a PDF File

Portable Document Format, or **.pdf** files, are one of the most universally compatible and efficient file formats and can be viewed and printed on most computer platforms.

You can save any view as a 2D **.pdf** file by selecting “Chief Architect Save as PDF” or any other PDF writer installed on your system as the Destination printer **Name** in either the Print View or Print Image dialog. See [Print View Dialog on page 1380](#) and [Print Image Dialog on page 1383](#).

You can also print to **.pdf** from any view by selecting **File> Export> Export PDF** . See [PDF Files on page 1198](#).

When you print to **.pdf**, you will be asked to create a file name and choose a destination to save it in the Save as PDF File dialog. See [Exporting Files on page 41](#).

You can also import **.pdf** file into Chief Architect. See [Importing PDF Files on page 1198](#).

---

## Line Weights

The weight of a line refers to its thickness on the printed page and is described in absolute terms as a fraction of a unit, often 1/100th of a millimeter or 1/1000 of an inch. In Chief Architect, line weights are assigned to objects, patterns, and layers using whole numbers that correspond to the numerator of this fraction.

You can specify the Line Weight Scale by defining the denominator and the unit used in this fraction in the Drawing Sheet Setup dialog. See [Drawing Sheet Setup Dialog on page 1367](#).



It is extremely important that every view sent to layout and the layout file share the same Line Weight Scale. When they do not, unwanted printed output will result.



Your preferred line weights and line weight scale can be saved in your template plan and layout files. See [Template Files on page 87](#).

The method for specifying an object’s line weight depends on the object and the type of view.

- Most objects’ line weights can be set by layer. See [Layer Display Options Dialog on page 179](#).
- Some objects’ line weights can be set in their specification dialogs. See [Line Style Panel on page 305](#).
- The line weights for walls in plan view are defined by wall type in the Wall Type Definitions dialog. See [Wall Type Definitions Dialog on page 387](#).

- The line weights of material pattern lines, which are visible in Vector Views, can be set in the Define Material dialog. See *Define Material Dialog on page 1066*.
- The line weight for fill patterns is set for individual objects in their specification dialogs. See *Fill Styles on page 192*.
- The line weight applied to surface edges in Vector Views can be set in the Print dialog. See *Print View Dialog on page 1380*.
- The end cap length of dashed lines in plan view is set in the Preferences dialog. See *CAD Panel on page 114*.
- An assigned line weight of 0 draws a line weight of 1 pixel, the thinnest line weight a printer allows. How thick this is varies from printer to printer. See *Printers and Plotters on page 1364*.

## LINE WEIGHTS AND SCALING

Line weights and line styles are subject to scaling when printed. You can see an on-screen approximation of what lines will look like when a view is printed by toggling on either **Line Weights**  or **Print Preview** . See *Print Preview on page 1371*.

When a view is sent to layout, line weights and styles may be further affected by the drawing scale selected for the layout view. This occurs when the layout view's scale is different from the Drawing Scale of the original view.

For example, assume that you have an object in a view with a line weight of 20, and that the view's Drawing Scale is 1 mm = 50 mm.

- If you send the view to layout at 1 mm = 25 mm scale, twice the original scale, the resulting printed line weight for this object will increase to 40 instead of 20.
- If you send the view to layout at 1 mm = 100 mm scale, half the original scale, the resulting printed line weight for this object will decrease to 10 instead of 20.

Line weight scaling affects both line weights and line styles and can be particularly noticeable with dashed line styles. See *Line Style Specification Dialog on page 201*.

For example, assume that you have an object in a view with a dashed line style that has 10 mm dashes and 10 mm spaces, and that the view's Drawing Scale is 1 mm = 50 mm.

- If you send the view to layout at 1 mm = 25 mm scale, twice the original scale, the resulting dashes and spaces will increase to 20 mm instead of 10 mm.
- If you send the view to layout at 1 mm = 100 mm scale, half the original scale, the resulting dashes and spaces will decrease to 5 mm instead of 10 mm.

You can specify the drawing scale for any orthogonal view by opening the Drawing Sheet Setup dialog while in that view. See *Printing to Scale on page 1372*.

For any layout view, you can specify whether the original line weight is maintained or not in the Send to Layout and Change Scale dialogs. See *Send To Layout Dialog on page 1339* and *Rescaling Views on page 1347*.

Note that in order to produce exact line weights, a Vector View must be sent to layout using the **Plot Lines** option. See *Plot Line Views on page 1343*.

Note: Under most circumstances, you should select Use Layout Line Scaling when sending views to layout.

In the following image, the same plan view has been sent to layout twice, at two different scales. The view on the left was sent at the same scale as the original view, 1/8" = 1'. The view on the right was sent at 1" = 1', or magnified eight times, to show an area of the plan in greater detail.

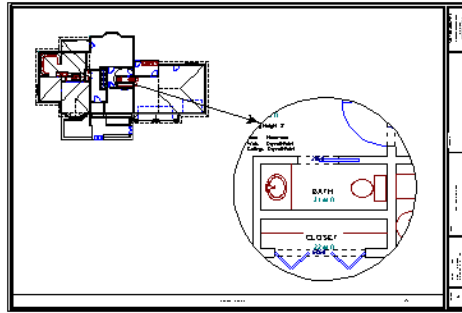

Because the view on the right was sent to layout at a scale other than that of the original, it is subject to layout line scaling.

The solid lines representing walls, cabinets and doors are rescaled to be eight times thicker than in the original view.

Similarly, the dashed lines representing the door jambs are rescaled so that the dashes and the spaces between them are eight times larger than in the original view.

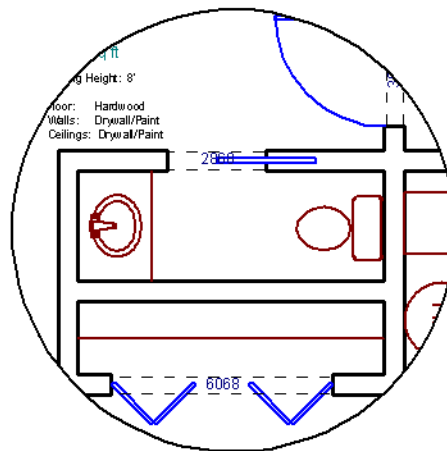

If **Use Layout Line Scaling** is enabled, line weights are no longer scaled and the dashed lines display at the same size as in the original view.

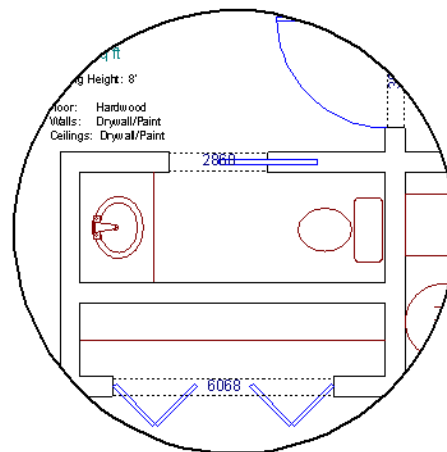

Because the view in this example is scaled eight times larger in this case, the dashes and line weights look relatively small and fine when **Use Layout Line Scaling** is enabled. Were the view rescaled to be smaller instead, the line weights would look relatively large and thick.



## PRINTERS AND LINE WEIGHT

Line weight and print scaling are subject to the limitations of the printer being used. For example, you will not be able to see the difference between a line that is 1/150th of an inch wide and one that is 1/300th of an inch wide when they are printed using a printer that prints 150 dots per inch (DPI).

That is, a CAD line with a line weight of 1 will look the same as a CAD line with a line weight of 4 when the Line Weight Scale is set at 1 = 1/600th of an inch and you print to a printer capable of 150 DPI.

Setting an object's or group of objects' line weight to zero causes the lines to print as thinly as possible.

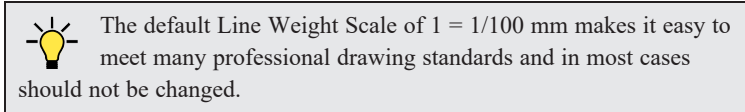

---

## Watermarks

 A customizable watermark containing text or the image of your choice can be added to any plan view or layout. To toggle the watermark on or off in the current view, select **View > Watermark**.

In layout files, the watermark will display on all pages when it is toggled on. In plan files, on the other hand, the Watermark toggle can be set on a view by view basis and can be saved in the Plan View Specification dialog, CAD Detail Specification, Camera Specification and Cross Section/Elevation Specification dialogs. See [View Specification Dialogs on page 146](#).

Watermarks also are file specific, so you can have a different watermark in each plan and layout file if you wish. If you want to use a particular watermark in all files, you can add it to your plan and layout templates. See [Template Files on page 87](#).

The method for printing a view with a watermark varies depending on the view type:

- For most types of views, check **Show Watermark** in the Print View dialog. See [Print View Dialog on page 1380](#).
- For perspective cameras and overviews, toggle the watermark on before printing. See [Saving and Printing 3D Views on page 1115](#).

Note: Student, Academic, and Presentation versions of the software produce a non-editable watermark on all printed documents. A second one can be added if you wish.

## WATERMARK DEFAULTS DIALOG

A watermark can be customized in the Watermark Defaults dialog. To open this dialog, select **Edit > Default Settings** and in the Default Settings dialog, click on “Watermark” and click the **Edit** button.

You can also open this dialog by clicking the **Define** button in the Print View dialog. See [Print View Dialog on page 1380](#).

When the Watermark Defaults dialog is open, the watermark will display in the view window behind the dialog and will update as changes are made to its settings.

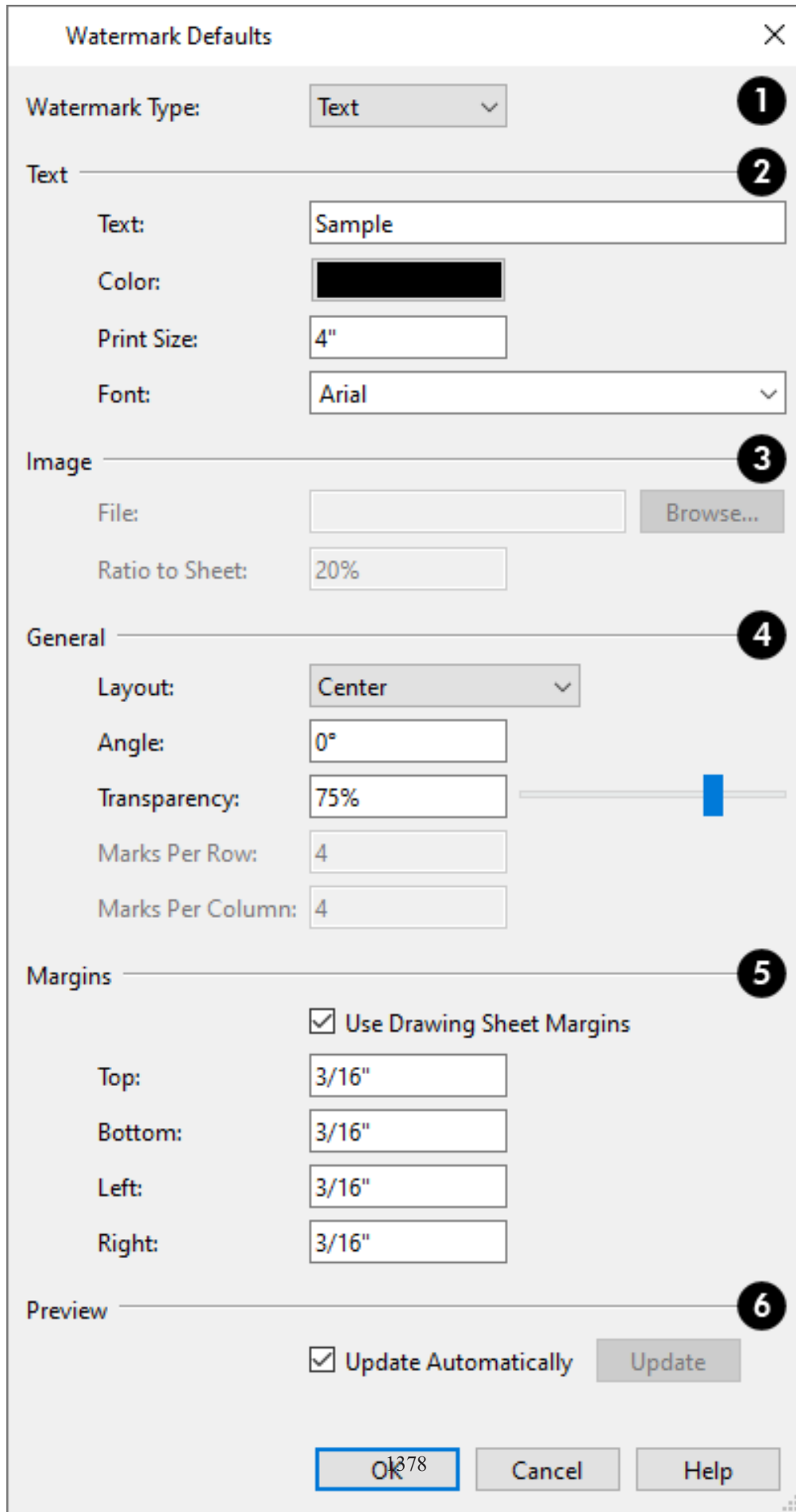

## 1 Watermark Type

Select a **Watermark Type** from the drop-down list.

## 2 Text

These settings are available when “Text” is the Watermark Type selected above.

- Type the desired watermark **Text** in the text field.
- Click the **Color** bar to select a color for the watermark text. See *Color Chooser/Select Color Dialog on page 203*.
- Specify the **Print Size** of the watermark text, as measured from the baseline to top of the capital letter A in the selected Font.
- Select a **Font** from the drop-down list.

## 3 Image

These settings are available when “Image” is the Watermark Type selected above.

- To select an image to use as the watermark, click the **Browse** button to open the Watermark Image File dialog, which is a typical Open dialog. See *Importing Files on page 45*.
- When an image **File** is specified, its pathname displays in the text field. You can type a different pathname if you wish. When you click OK, however, the image reported here becomes embedded in the current plan or layout and will no longer be listed in this field if you return to this dialog.
- Specify the **Ratio to Sheet**, which is how far the image extends across the sheet. Not available when “Fit to Sheet” Layout is selected, below.

## 4 General

- Specify the **Layout** of the watermark from the drop-down list.
- Specify the watermark’s **Angle**, measured relative to a horizontal line pointing towards the right-hand side of the screen.
- Use the **Transparency** slider bar or text field to control how transparent the watermark is.
- The Marks Per settings are only available when “Tile” or “Border” is selected as the Layout, above.
- Specify the **Marks Per Row**, which is the number of instances of the watermark across the width of the Drawing Sheet.
- Specify the **Marks Per Column**, which is the number of instances of the watermark from top to bottom of the Drawing Sheet.

## 5 Margins

Specify the watermark **Margins**, measured in from the edges of the Drawing Sheet.

- Check **Use Drawing Sheet Margin** to use the same margins for the watermark that are specified for the Drawing Sheet or uncheck this box to enable the settings that follow. See *Drawing Sheet Setup Dialog on page 1367*.
- Specify the width of the **Top**, **Bottom**, **Left**, and **Right** watermark margins.
- Check **Update Automatically** to have the watermark update in the current view as changes are made in the dialog.

- Click the **Update** button to update the watermark in the view behind the dialog. Not available if Update Automatically is checked above.

## 6 Preview

- Check **Update Automatically** to have the watermark update in the current view as changes are made in the dialog.
- Click the **Update** button to update the watermark in the view behind the dialog. Not available if Update Automatically is checked above.

---

## Print View Dialog



To print from plan views, 3D Vector Views, layout, CAD Details, Time Tracker Logs, or the Materials List, select **File> Print> Print**. The Print View, Print Layout, Print Time Tracker Log, or Print Materials List dialog opens. The settings that are available will vary depending on which version of the dialog is open.



Select **File> Export> Export PDF** to open the similar Export PDF dialog.

Note: 3D views that are not Vector Views can be printed using Print Image. See *Print Image Dialog on page 1383*.

If **Remember Print Settings after Printing** is checked in the Drawing Sheet Setup dialog, most settings in this dialog will be saved and applied globally to all views of the same type in all Chief Architect files. There are three exceptions: **Sheets** and **Copies** are always reset, and the **Print Source** is determined by whether or not the **Drawing Sheet**  is toggled on. See *Print View Settings on page 1366*.

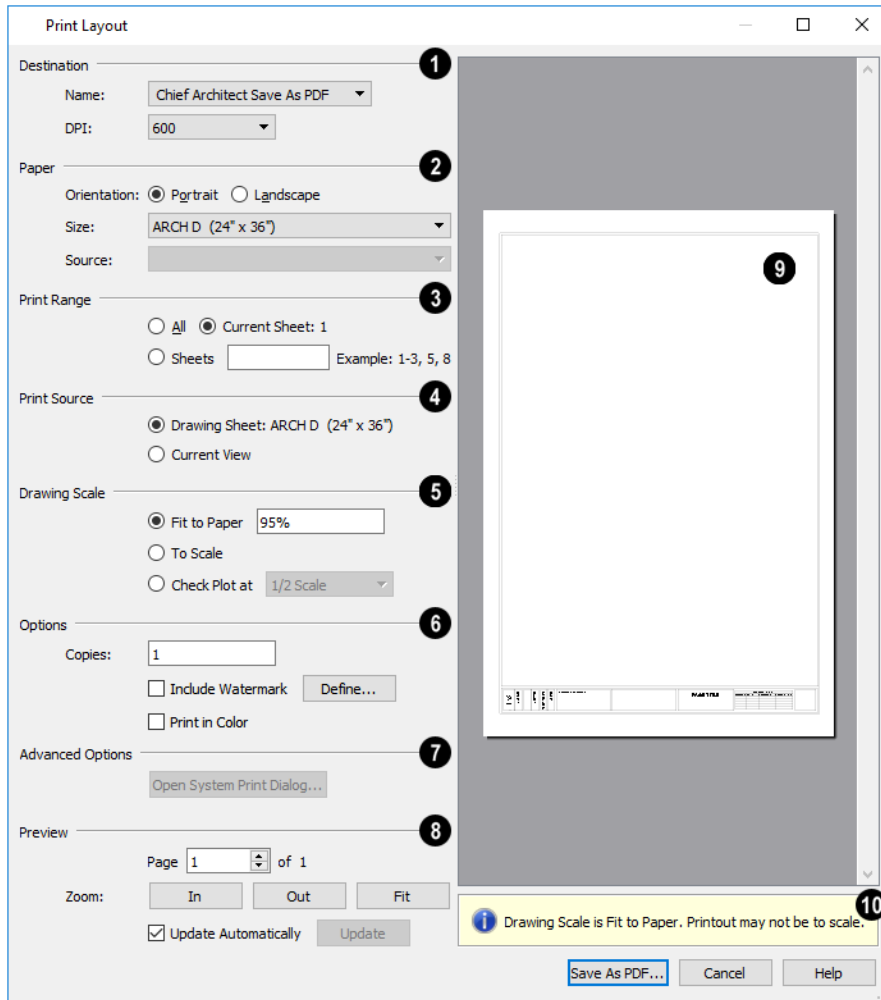

### 1 Destination

- Select the **Name** of the printer you would like to use from the drop-down list. To print to **.pdf**, select “Chief Architect Save as PDF” from the list, or choose a **.pdf** writer installed on your system. See [Printing to a PDF File on page 1374](#).
- Select the **DPI**, or Dots Per Inch to use when printing, from the drop-down list. The available options may vary depending on the selected printer.

### 2 Paper

Select the **Paper Orientation**, **Size**, and **Source**. The available Size and Source options are controlled by the selected printer’s driver. See [Printer Drivers on page 1365](#).

- When possible, the program will automatically set the Size and Orientation to match those of the Drawing Sheet. See [Drawing Sheet Setup Dialog on page 1367](#).
- The Paper Size may be automatically adjusted if the Drawing Scale option is changed, below.

### 3 Print Range

In layout files only, specify the range of pages to print. Only pages that have views or objects drawn directly on them and

are not specified as Page Templates will print. Page Templates and empty pages do not print. See [Layout Page Templates on page 1358](#).

- Select **All** to print the entire drawing.
- Select **Current Sheet** to print only the currently active layout page.
- Select **Sheets** to specify which layout pages to print, then type the page numbers you wish to print, separated by commas or by a dash. Not available in plan files.

Note: To produce collated multiple copies, specify the sheets in the desired order, separated by commas.

#### 4 Print Source

Not available in the Print Materials List dialog.

- Select **Drawing Sheet** to print the entire sheet even though you may be zoomed in on a portion of the view. This is selected by default when the Drawing Sheet is set to display in the current view.
- Select **Current View** to print only that portion of the active view that is currently visible on screen. If you are zoomed out, any blank space outside the printable objects in the view is ignored. This is selected by default when the Drawing Sheet is not displaying in the current view.

#### 5 Drawing Scale

Changes to these options may cause the Paper Size to change, above. Not available in the Print Materials List dialog or in camera views or overviews. See [Printing to Scale on page 1372](#).

- **Fit to Paper** prints the view on one page. The program uses whatever scale is necessary to fit the plan on one page.
- When **Fit to Paper** is selected, specify the percentage of the paper to be used. The default value is 95%.

Note: The Fit to Paper percentage value is global - affecting all views in all files, and is retained between sessions.

- Select **To Scale** to print at the scale specified in the Drawing Sheet Setup dialog. See [Drawing Sheet Setup Dialog on page 1367](#).
- To print a check plot, select **Check Plot at** and choose a scale adjustment from the drop-down list. See [Check Plots on page 1373](#).

#### 6 Options

- Specify the number of **Copies** you would like to print.
- Check **Include Watermark** to include a watermark in the printed output. Click the **Define** button to open the Watermark Defaults dialog. See [Watermark Defaults Dialog on page 1377](#).
- Check **Print in Color** to print in color or clear the check box to print in either grayscale or black and white. In the Print Materials List and Print Time Tracker Log dialogs, system default colors are used when this box is unchecked.
- To print in grayscale, check **Obey Color On/Off Setting** in the Preferences dialog before printing, then uncheck **Print in Color**. See [Appearance Panel on page 95](#).

- To print in black and white, uncheck **Obey Color On/Off Setting** in the Preferences dialog before printing, then uncheck **Print in Color**. Lines and fill colors print as either black or white, depending on which is closer to the line or fill's actual color.
- Most black and white printers print a grayscale approximation of the colors if **Print in Color** is selected.

## 7 Advanced Options

Click the **Open System Print Dialog** button to close the Print View dialog and print using your operating system's Print dialog instead. Not available when No Printer is selected.

## 8 Preview

Control the appearance of the print job preview on the right side of the dialog.

- Specify the **Page** that displays in the Preview area.
- Click the buttons to **Zoom In**, **Zoom Out**, or **Fit** the selected Page to the extents of the Preview area.
- Uncheck **Update Automatically** to turn off the print job Preview and prevent it from updating as changes are made to the settings in this dialog.
- Click the **Update** button to update the print job Preview to reflect the current settings in this dialog. If Update Automatically is unchecked, clicking Update may force the Preview to be blank.

## 9 Preview Pane

- When **Update Automatically** is checked, a preview of the current print job displays here. The drawing sheet displays as a white rectangle, and if multiple sheets are required, you can scroll through them. If the print job is large, a progress dialog may display briefly as the preview draws or updates.

## 10 Information

To help prevent unwanted printed output, information messages regarding page size, resolution, and scale may display below the preview pane, depending on the settings in this dialog.

---

# Print Image Dialog



Any view can be printed by selecting **File> Print Image**. This is the only way to print a Ray Trace or most 3D views. See [3D Rendering on page 1131](#).

The Print Image dialog is similar to the Print View dialog; however, the printing process is different. **Print Image** prints individual pixels as opposed to vectors (lines).



Before printing a GPU Ray Trace camera view, you may want to make sure that it is denoised. See [Denoising on page 1132](#).

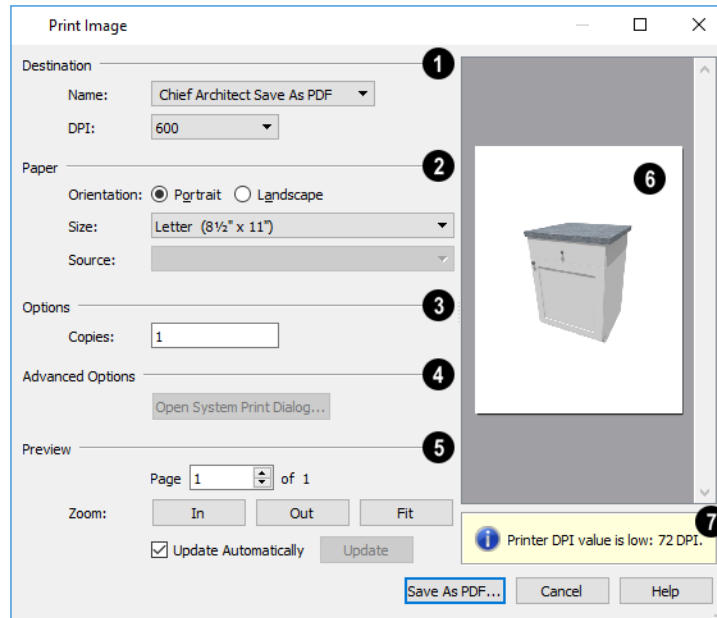

### 1 Destination

Select the Name of the **Printer** you wish to use from the drop-down list. To print to **.pdf**, select “Chief Architect Save as PDF” from the list, or choose a **.pdf** writer installed on your system. See [Printing to a PDF File on page 1374](#).

- Select the **DPI**, or Dots Per Inch to use when printing, from the drop-down list. The available options may vary depending on the selected printer.

### 2 Paper

Select the **Paper Orientation**, **Size**, and **Source**. The available Size and Source options are controlled by the selected printer’s driver. See [Printer Drivers on page 1365](#).

### 3 Options

Specify the number of **Copies** you would like to print.

### 4 Advanced Options

Click the **Open System Print Dialog** button to close the Print View dialog and print using your operating system’s Print dialog instead. Not available when No Printer is selected.

### 5 Preview

Control the appearance of the print job **Preview** on the right side of the dialog.

- Specify which **Page** displays in the Preview area.
- Click the buttons to **Zoom In**, **Zoom Out**, or **Fit** the selected Page to the extents of the Preview.
- Uncheck **Update Automatically** to turn off the print job Preview and prevent it from updating as changes are made to the settings in this dialog.
- Click the **Update** button to update the print job Preview to reflect the current settings in this dialog. If Update Automatically is unchecked, clicking Update may force the Preview to be blank.



## **6 Preview Pane**

When **Update Automatically** is checked, a preview of the current print job is displayed to the right. If the print job is large, a progress dialog may display briefly as the preview draws or updates.

## **7 Information**

To help prevent unwanted printed output, information messages regarding page size and resolution may display here, depending on the settings in this dialog.

# Ruby in Chief Architect

## Chapter 43

Ruby is a popular, open-source programming language that can be used for a wide variety of purposes.

In Chief Architect Premier, you can use Ruby 2.4.0 to create custom macros which can be used to produce object labels for specific needs and customized Materials List calculations. You can also type Ruby macro code bookended by percent signs into text objects and object labels.

Ruby is considered to be easy to use by its many users - not all of whom are software developers. If you'd like to learn more, visit: [www.ruby-lang.org](http://www.ruby-lang.org).

### TOPICS

<b>Creating User Defined Macros</b> .....	<b>1387</b>
<b>Working with NVPublishers</b> .....	<b>1387</b>
<b>Working with Name-Value Pairs</b> .....	<b>1389</b>
<b>Macros and Context</b> .....	<b>1390</b>
<b>Measurement and NumberFormatter Classes</b> .....	<b>1393</b>
<b>Text Macro Management Dialog</b> .....	<b>1396</b>
<b>The Ruby Console</b> .....	<b>1399</b>
<b>Viewing the Interactive Tutorial</b> .....	<b>1401</b>
<b>Migrating Legacy Ruby Code</b> .....	<b>1401</b>

---

## Creating User Defined Macros

You can create your own custom macros for a variety of purposes in Chief Architect Premier, including:

- Shortcuts for strings of text that are used repeatedly throughout a project. For examples, see *Designer/Client Information on page 541*.
- Custom object labels. See *Label Panel on page 700*.
- Custom labels inserted into text objects, callouts, and markers in plan view. See *Referenced Object Context on page 1391*.
- Object Information that can be included in schedules and the Materials List. See *Object Information Panel on page 1331*.
- Materials List formulas. See *Materials List Formulas on page 1320*.

There are two broad categories of macro:

- Text macros are essentially shortcuts that replace long strings of text with an inserted macro. Text macros can include Global macros with general information about the current view or file, but they cannot perform calculations.
- Ruby macros, on other hand, can include Name-Value Pairs, perform calculations, and even reference scripts written in Ruby. They do not, however, use regular text. In order to function, the information in each Ruby macro must have a defined Context: Owner Object, Referenced Object, or Materials List Line Item.



Macros will update whenever the display is redrawn. You can prompt the screen to redraw by zooming, panning, or selecting View> Refresh Display. See *Window and View Tools on page 143*.

### NAME-VALUE PAIRS AND PUBLISHERS

At the heart of most Ruby macros are Name-Value Pairs, or NVPs, and Name-Value Publishers, or publishers. A publisher is simply an object that has attributes that can be reported by a Ruby macro, and an NVP is the name of such an attribute and its value. For example:

- A cabinet is an example of a publisher.
- The name of one of its attributes is height.
- 36" is the value reported by height in a basic macro in a plan using US units.

Most objects in Chief Architect Premier have a selection of NVPs which can be used to report information about them in Ruby macros. See *To view a publisher's Name-Value Pairs on page 1388*.

A Name-Value Pair can be used as a simple macro by bookending it with percent signs. For example, %height% will report the height of a wide variety of objects. See *To insert a macro on page 541*.

### CREATING AND EVALUATING CUSTOM MACROS

Custom Ruby macros are created in the Edit Text Macro dialog. See *Edit Text Macro Dialog on page 1397*.

Custom macros can be evaluated in the Ruby Console. See *The Ruby Console on page 1399*.

---

## Working with NVPublishers

NVPublishers, or publishers, are objects in Premier that have attributes that can be reported by a Ruby macro.

In plan view, a publisher can either be an Owner Object or a Referenced Object.

- An Owner Object reports its own attributes directly in a label or using Object Information in a schedule or materials list.
- A Referenced Object's attributes are reported by a macro inserted into a text object that is connected to the publisher by a line with arrow. See [Referenced Object Context on page 1391](#).

### **To view a publisher's Name-Value Pairs**

1. Select **Tools> Ruby Console** .
2. Select an object in your plan - for example a base cabinet. This is an Owner Object.
3. Type **owner.names** in the Input text field of the Ruby Console and press the Enter key.
4. An array of NVPs will display in the Output field. These values are all attributes of the selected object.
5. To view the array as a list, type **puts owner.names** and press Enter.

You can request the NVPs for a Referenced Object just as you can for an Owner Object: select the Referenced Object and open the Ruby Console. Then, instead of typing `owner.names`, type **referenced.names** (or **puts referenced.names**).

Note: The name-value pairs for rooms cannot be used to create Referenced Object macros. They only work as Owner Object macros. A number of macros that describe rooms are available as Global Macros, which do work when placed in a Text object located inside a room.

## **RELATED OBJECTS**

A given publisher may have NVPs that report information about objects associated with the publisher rather than about the publisher itself. For example, a base cabinet often has:

- An automatic countertop, which is a feature of the cabinet parametric object but is a publisher in its own right and has its own set of NVPs.
- Door and drawer panels, which are library symbols that are inserted into the cabinet. See [Inserted Objects on page 973](#).
- Moldings, which are library items assigned to the cabinet.
- A room that the cabinet is located in.

These related objects are all publishers themselves and have their own NVPs.

### **To view an object's related publishers**

1. Use the **Leader Line**  tool to create a Text Line with Arrow snapped to the object on the arrow end. See [Leader Line on page 519](#).
2. In the Rich Text Specification dialog, type or insert the `%object_properties%` User Defined macro. See [To insert a macro on page 541](#).
3. When you click OK, the text will report all NVPs, NVPublishers, and Collections associated with the object that the arrow is snapped to.

Note: The `%object_properties%` macro cannot be used with a Leader Line to view the related publishers of a room. Instead, place the Text object inside the room.

To include a related object's NVPs in a macro, use this format: `related_publisher_name.nvp_name`.

Related objects may also be nested more than one layer deep: `related_publisher_name.related_publisher_name.nvp_name`.

## COLLECTIONS

Some objects can have more than one of a particular type of related object. For example, a cabinet may have multiple door or drawer panels. Each panel is an NVPublisher listed in a Collection. The layers of structural assemblies like walls are also listed in Collections.

There are two main ways to use Collections in a Ruby macro:

- Access elements at a specific index, like an Array:

```
collection_name[index].nvp_name
```

- Use a different Enumerable method with a Ruby block. Use this format, in which “parameter\_name” can be replaced with any name/identifier:

```
collection_name.enumerable_method  
{ |parameter_name| parameter_name.nvp_name }
```

For more information, see: <https://ruby-doc.org/core-2.4.0/Enumerable.html>.

## ROOMS

Like other objects, rooms are publishers with related objects and collections associated with them. They are unusual, however, in that if an otherwise independently placed object is positioned inside a room, that object will have NVPs that report information about the room.

This means that a text object placed inside a room can serve as a custom label, using a macro to report dynamic information about the room.

- To add an NVP to a text object that reports information about the room the text is located in, use this format: `room.nvp_name`. See *Working with NVPublishers on page 1387*.
- To create a custom macro to insert in a text object that reports information about the room the text is located in, use the Owner Object context and make sure "room" is defined as the publisher for all variables. See *Owner Object Context on page 1391*.

It also means that architectural objects can report information about the room they are in in their labels, in schedules, and in the Materials List. Objects that are not located entirely inside one room - including doors, windows, and any other object that extends beyond the extents of a single room - do not have this ability.

---

## Working with Name-Value Pairs

NVP Names use all lower case characters and separate words using an underscore `_` instead of a space.

- **Integer** values are whole numbers.
- **Float** values are numbers with decimal points.
- **Measurement** values are a custom class that have numbers with decimal points and a unit of measurement. See *Measurement Class on page 1393*.
- **TrueClass** reports that the publisher object has a particular attribute.
- **FalseClass** reports that the publisher can have a particular attribute but does not.
- **NilClass** reports that the publisher has a particular attribute, but that it doesn't apply in the current instance.

- **String** values are composed of text.
- **Symbol** values are similar to text.
- **NVPublishers** identify related objects.
- **Collections** identify collections of related objects.
- **Hash** identifies a collection of user-specified Custom Object Fields and is only returned by the `custom_fields` NVP.

There are two ways to view the NVPs associated with an object:

- The Ruby Console can report all NVPs associated with a selected object.
- The `%object_information%` macro can report all NVPs, NVPublishers, and Collections associated with an object.

## HASHES

Ruby Hashes are collections of key-value pairs. In Chief Architect Premier, they can be used to access the information in Custom Object Fields. See [Custom Object Fields on page 690](#).

To include a Hash in a macro, use this format: `custom_fields["custom field name"]`.

## NAME VALUE PAIRS AND DEFAULTS

A number of NVPs for various objects end in `'_is_default'`. These NVPs will return either `'true'` or `'false'`, depending on whether the object in question is set to use the dynamic default for that attribute. See [Dynamic Defaults on page 79](#).

---

# Macros and Context

Ruby macros can be used in different contexts, but in order for the Name-Value Pairs in a macro to report the correct information, the macro needs to identify the context it is designed to be used in.

## NON-EVALUATED TEXT MACROS

Non-evaluated text macros primarily act as shortcuts for strings of text that you use often in your work. They are dynamic, so if you need to modify a string, you can simply edit the associated macro instead of locating and changing every instance of the text in the plan or layout file.

Non-evaluated text macros cannot display dynamic information about a particular object or perform calculations, however.

### *To create a non-evaluated text macros*

1. Open the Text Macro Management dialog and click the **New** button.
2. In the Edit Text Macro dialog:
  - Type the desired text.
  - Insert any Global text macros that you need. Non-evaluated User Defined macros can also be included.
  - Inserted macros should use the format: `%macro_name%`.
  - Leave the **Evaluate** check box unchecked.
3. Confirm that the macro is valid by checking its **Expanded Macro Value** in the Text Macro Management dialog.

The resulting macro can be inserted into a text object. Although it cannot not display dynamic information about a particular object or perform calculations, it can also be inserted into an object's label or added to its Object Information.

## OWNER OBJECT CONTEXT

The Owner Object context allows a macro to perform calculations and dynamically report information about an object in its label and Object Information.

### *To create an Owner Object macro*

1. Select an object for which you would like to create a custom macro.
2. With the object selected, open the Text Macro Management dialog and click the **New** button.
3. In the Edit Text Macro dialog:
  - You can use any NVPs associated with the selected object in the macro. See *Working with Name-Value Pairs on page 1389*.
  - NVPs do not require special formatting, but macros inserted using the %macro\_name% format cannot be used.
  - To include a Ruby macro within another Ruby macro, use this format: `macros.macro_name`.
  - When the intended owner is a text object reporting information about a room, use this format: `room.nvp_name`. See *Working with NVPublishers on page 1387*.
  - Check **Evaluate** and select “Owner Object” from the **Context** drop-down list.
4. Confirm that the macro is valid by checking its **Expanded Macro Value** in the Text Macro Management dialog.

The resulting macro can be inserted into the label for any object for which it is Valid.

## REFERENCED OBJECT CONTEXT

When a Ruby macro is assigned the Referenced Object context, it can be inserted into text with an arrow pointing to the object it refers to and then perform calculations or report information about that object.

### *To create a Referenced Object macro*

1. Select a text object with an arrow that is snapped to an object for which you would like to create a custom macro.
2. Open the Text Macro Management dialog and click the **New** button.
3. In the Edit Text Macro dialog:
  - You can use any NVPs associated with the object that the text arrow is pointed to.
  - NVPs do not require special formatting, but macros inserted using the %macro\_name% format cannot be used.
  - To include a Ruby macro within another Ruby macro, use this format: `macros.macro_name>`.
  - Check **Evaluate** and select “Referenced Object” from the **Context** drop-down list.
4. Confirm that the macro is valid by checking its **Expanded Macro Value** in the Text Macro Management dialog.

### *To use a Referenced Object macro*

1. Insert the custom macros into a Text, Rich Text, Callout, or Marker object.
2. Draw a Text Line with Arrow between the text object and the object that your Referenced Object macro describes.

Note: Referenced Object macros cannot be used with a Leader Line to report information about a room. Instead, use the Owner Object context, place the Text object inside the room, and use a macro in which "room" is defined as the publisher for all variables. See *Owner Object Context on page 1391*, above.



## MATERIALS LIST LINE ITEM CONTEXT

A Materials List Line Item macro can be inserted into a cell in a materials list.

### *To create a Materials List Line Item macro*

1. Open the Text Macro Management dialog and click the **New** button.
2. In the Edit Text Macro dialog:
  - You can use any Name-Value Pairs associated with the object that the macro is meant to describe.
  - Name-Value Pairs do not require special formatting, but macros inserted using the %macro\_name% format cannot be used.
  - To include a Ruby macro within another Ruby macro, use this format: `macros.macro_name`.
  - Check **Evaluate** and select "Materials List Line Item" from the **Context** drop-down list.
3. Unlike other types of macros, its validity cannot be confirmed in the Text Macro Management dialog.

### *To use a Materials List Line Item macro*

1. Select an object and click the **Open Object** edit button.
2. On the COMPONENTS panel of the specification dialog, select a component or subcomponent associated with the object.
3. Click in a Formula cell to select it, then click a second time to edit the cell.
4. Select **Apply Formula to Source Object** .
5. Click the **Insert Macro**  button and insert a macro.

Macros can also be inserted in the Materials List in a similar manner. See *To insert a custom Materials List formula on page 1321*.

## CONTEXTLESS MACROS

Select "None" as the Context for a Ruby macro if you would prefer to define the Context within the macro's Value.

To do this, type the Context before each NVP in the macro using this format:

- `owner.name_value`
- `referenced.name_value`
- `line_item.name_value`



## Measurement and NumberFormatter Classes

Chief Architect Premier uses two custom Ruby classes that clarify and allow control of the units and formatting used by measurements: Measurement and NumberFormatter.

### MEASUREMENT CLASS

All Name-Value Pairs that return length, area, or volume values do so by reporting a Measurement. A Measurement includes both a numeric value and a unit. The program has a set of hard-coded default units that can be used, and Custom Unit Conversions are supported as well. See [Add Unit Conversion Dialog on page 111](#).

The default unit used by a Measurement depends on its category as well as whether the file uses U.S. (“Imperial”) or metric units:

Category	Default Units
Linear	Inches or millimeters
Area	Square feet or square meters
Volume	Cubic feet or cubic meters
Unitless	None
Anything else	Items without precedent are represented in a power of inches or cm.

Although Measurements have a unit, it is not reported unless you create a custom format. See [NumberFormatter Class on page 1394](#), below.

### MEASUREMENT-SPECIFIC METHODS

The Measurement class is not derived from the Numeric class but has many of the same methods. It also has a small set of custom methods:

Measurement-Specific Method	Return	Comments
<code>compatible_with?(other: Measurement)</code>	True   False	Returns True if other is compatible.
<code>to_s(unit: Symbol   String = "")</code>	String	Converts into a formatted representation of a Measurement. If a unit is provided, it must be compatible with the Measurement's type (linear, area, volume).
<code>to_f(unit: Symbol   String = "")</code>	Float	Converts into a float with optional unit argument. If a unit is not provided, the result is converted to the appropriate default unit.
<code>convert_to(unit: Symbol   String)</code>	Float	Converts into the specified unit. Raises an exception if the unit is incompatible.
<code>new([value: Float] = 0.0, [unit: Symbol   String] = "")</code>	Measurement	Creates a new Measurement. If unit is not an empty String, it must be a defined unit.

Measurement-Specific Method	Return	Comments
<code>type()</code>	String	The "category" of measurement: "Linear", "Area", "Volume", "Unitless", or "Derived".
<code>unitless?()</code>	True   False	Returns True if the Measurement is unitless.

### CONVERSION METHODS

The following units in Chief Architect Premier have hard-coded methods to convert a Numeric to a Measurement and vice versa:

- Linear: inch, in, foot, ft, yard, yd, mm, cm, dm, m
- Area: Prefix “sq\_” to any of the above
- Volume: Prefix “cu\_” to any of the above

Conversion Method	Return	Comments
<code>to_measurement([unit: Symbol   String] = "")</code>  <b>SHORTCUT:</b> <code>.(unit)</code>	Measurement	Returns a Measurement equivalent to "self.to_f unit". Omitting unit will produce a unitless Measurement.  +, -, *, and / operators will coerce the Numeric into a unitless Measurement.
<code>convert_to(unit: Symbol   String)</code>  <b>SHORTCUT:</b> <code>.to_(unit)</code>	Float	Converts into the specified unit.

### NUMBERFORMATTER CLASS

Chief Architect Premier’s default format for Measurements uses up to 6 decimal places, a leading zero, and no trailing zeroes. It does not include a unit. The NumberFormatter class allows you to create formatting for Measurements to meet your needs.

### NUMBERFORMATTER METHODS

NumberFormatter Method	Return	Comments
<code>apply(value: Numeric   Measurement)</code>	String	Formats the given value. If it is a Measurement of type Linear, Area, or Volume, it must have a compatible unit.
<code>inspect()</code>	String	Lists the current settings of the formatter.
<code>unit()</code>	String	The unit the formatter is currently using.
<code>unit=(unit: Symbol   String)</code>		Sets the unit the formatter will use. Mixed units ("ft-in") and undefined units are supported.
<code>show_unit()</code>	True   False	Reports whether the formatter will include the unit in the output.
<code>show_unit=(True   False)</code>		Sets whether the formatter will include the unit in the output.

NumberFormatter Method	Return	Comments
<code>show_leading_zero()</code>	True   False	Reports whether the formatter will include a leading zero.
<code>show_leading_zero=(True   False)</code>		Sets whether the formatter will include trailing zeros.
<code>show_trailing_zeros()</code>	True   False	Reports whether the formatter will include trailing zeros.
<code>show_trailing_zeros=(True   False)</code>		Sets whether the formatter will include trailing zeros.
<code>use_fractions()</code>	True   False	Reports whether the formatter will display fractions (True) or decimals (False).
<code>use_fractions=(True   False)</code>		Sets whether the formatter will display fractions (True) or decimals (False).
<code>decimal_places()</code>	Fixnum	Reports the maximum number of decimal places the formatter will use when not displaying fractions.
<code>decimal_places=(Fixnum)</code>		Sets the maximum number of decimal places the formatter will use when not displaying fractions. Must be $\geq 0$ .
<code>denominator()</code>	Fixnum	Reports the denominator the formatter will use when displaying fractions.
<code>denominator=(Fixnum)</code>		Sets the denominator the formatter will use when displaying fractions. Must be $\geq 1$ .
<code>thousands_separator()</code>	String	The thousands separator displayed for numbers greater than 999. An empty String represents no thousands separator.
<code>thousands_separator=(separator: String)</code>		Sets the thousands separator displayed for numbers greater than 999. An empty String represents no thousands separator.
<code>show_denominator()</code>	True   False	Reports whether the denominator will be shown when displaying fractions.
<code>show_denominator=(True   False)</code>		Sets whether the denominator will be shown when displaying fractions. When the denominator is hidden, fractions are never reduced.
<code>reduce_fractions()</code>	String   False	Reports the method used to reduce fractions, if any. Returns False if fractions aren't reduced.
<code>reduce_fractions=(method: :gcd   :closest   :none   ""   False)</code>		Sets the method used to reduce fractions. :gcd or "gcd" will use the greatest common divisor of the passed in value and the denominator. :closest or "closest" will ignore the set denominator and try to pick the closest equivalent fraction. :none, an empty String, or False will prevent fractions from being reduced and always use the set denominator.

## Text Macro Management Dialog

 A list of all user-defined text macros present in the current plan or layout file can be accessed by selecting **CAD> Text> Text Macro Management**.

- If you wish to create a user defined macro for an object, or find out whether an existing macro is valid for an object, open this dialog while the object is selected.
- To create a user-defined macro to be inserted into a text object that describes another object, or to find out whether such a macro is valid, select a text object with an arrow pointing to the object in question and then open this dialog. See *Macros and Context on page 1390*.

An object-specific version of this dialog is also available for objects saved in an unlocked library. Right-click on a single object of a type able to display labels and select **Text Macro Management** from the contextual menu. See *Using the Contextual Menu on page 951*.

- Any Owner Object macros assigned to the object’s label when it is added to the library are listed here. Note that objects in some manufacturer catalogs may include macros. See *Manufacturer Catalogs on page 961*.
- Custom macros can be imported to and exported from a library object, and additional macros can be added to the object, but you cannot specify them as part of a label while it is in the library.
- When the object is added to a plan, any macros associated with it are added to the plan, as well.

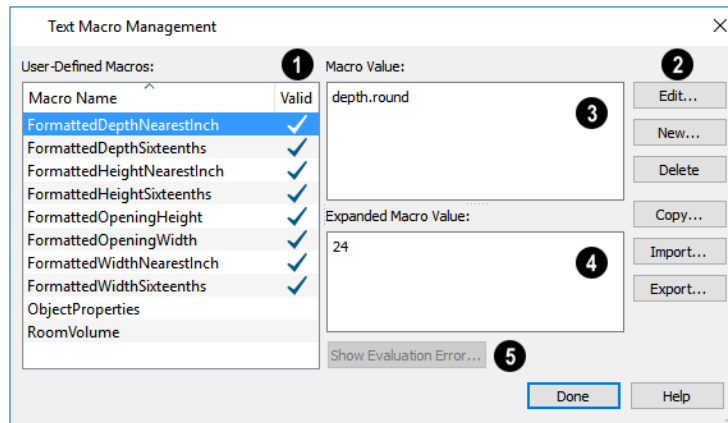

### 1 User Defined Macros

An alphabetical list of all **User-Defined Macros** present in the current file displays here.

- Click on the **Name** of a macro to select it.
- If a macro is **Valid** in the current context, a check mark will display to the right of its Name. See *Macros and Context on page 1390*.
- In legacy files, macros using deprecated behaviors may be present. When this is the case, an additional Info column will be present. See *Migrating Legacy Ruby Code on page 1401*.
- Information about a selected macro displays in the Macro Value and Expanded Macro Value fields to the right of the list. The Macro Value field shows the defined Value of the selected macro. The Expanded Macro Value shows the output of the macro in the current context.

### 2 Buttons

Edit or delete the selected text macro, create a new one, or import or export macros to and from other files. See *Importing*

and [Exporting Macros on page 1399](#), below.

- Click the **Edit** button to make changes to the selected macro in the Edit Text Macro dialog. Only available when an existing macro is selected.
- Click the **New** button to open the Edit Text Macro dialog and create a new macro.
- Click the **Copy** button to create a copy of the currently selected macro and open the Edit Text Macro dialog. Only available when an existing macro is selected.
- Click the **Delete** button to remove the selected macro from the list. Only available when an existing macro is selected.
- Click the **Import** button to open the Import Text Macros dialog and import macros exported from another file into the current file. See [Importing Files on page 45](#).
- Click the **Export** button to open the Export Text Macros dialog and make the user-defined macros in this file available to be imported into another file. See [Exporting Files on page 41](#).
- Click the **Migrate** button to migrate a legacy macro to the latest version. Only available when a legacy macro is selected. See [Migrating Legacy Ruby Code on page 1401](#).

### **3** Macro Value

The **Macro Value** field displays the content, or text used to define the selected macro.

### **4** Expanded Macro Value

The **Expanded Macro Value** field displays the information that the macro reports. If the selected macro is not Valid in the current context, “#Evaluation Error#” will display here,

### **5** Show Evaluation Error

If the selected macro is not Valid, click the **Show Evaluation Error** button to open an Information box with a description of the problem. See [Macros and Context on page 1390](#).

## **EDIT TEXT MACRO DIALOG**

The Edit Text Macro dialog can be accessed by clicking the **Edit**, **New**, or **Copy** button in the Text Macro Management dialog.

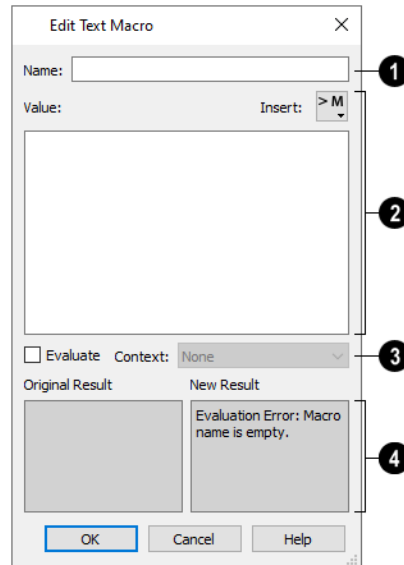

### 1 Name

Type a short, descriptive **Name** for the macro. Macro names must be unique within a given file, or library object.

To avoid unexpected results, a macro should not have the same name as an NVP Name, NVPublisher, or Collection.

### 2 Value

Type a macro using the Ruby 2.4.0 programming language in the **Value** field. NVPs existing macros, and references to Ruby **.rb** files can be included.

- You can also copy an NVP out of the Ruby Console or a definition from an **.rb** file and paste it here. See [To Copy, Cut and Paste text on page 515](#).
- Click the **Insert** button above the Value field to insert an already existing macro into the selected macro. See [To insert a macro on page 541](#).

Note: Chief Architect Premier uses Ruby 2.4.0.

### 3 Context

To create a Ruby macro with a context, check the **Evaluate** box, then select a **Context** from the drop-down list. When unchecked, a text macro will be created. See [Non-Evaluated Text Macros on page 1390](#).

- Choose **None** if the macro performs a function but doesn't refer to an object or if the macro's context - or contexts - are stated in its Value.
- Choose **Owner Object** to create a macro for use in an object label.
- Choose **Referenced Object** to create a macro for use in a Text object with an arrow that points at an object that the macro describes.
- Choose **Materials List Line Item** to create a macro for use in the Materials List.

If the selected macro is a legacy macro using deprecated behavior, additional options will be available. See [Migrating Legacy Ruby Code on page 1401](#).

- Click the **Migrate Formula** button to open the Migrate Ruby dialog.

- After migrating the macro but before clicking OK in this dialog, you can click the **Revert to Legacy** button. This button is only available until you exit out of the dialog.

#### 4 Results

For comparison purposes, the **Original Result** and **New Result** fields report Data Type and Value information when the selected macro is valid, or Evaluation Error information when it is not.

- The **Original Result** field reports information about the macro as it was when the dialog was first opened. This field will be blank for a newly created macro.
- The **New Result** field reports information based on changes made since the dialog was opened.

Click OK to return to the Text Macro Management dialog.

### IMPORTING AND EXPORTING MACROS

User-defined text macros can be exported out of one plan file, layout file, or library object and imported into another file or object using the Text Macro Management dialog.

If the program encounters macros with duplicate names when importing into a plan or layout file, the Text Macro Name Conflict dialog will display, allowing you to choose how to handle the name conflict.

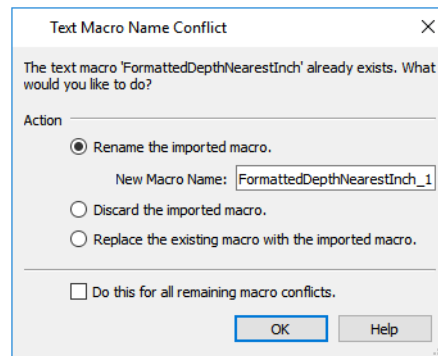

- Select **Rename the imported macro** to keep both the existing macro and the one being imported. Then, type a short, descriptive, unique **New Macro Name**. By default, the new name is simply the original name appended by a number.
- Select **Discard the imported macro** to use the existing macro already present in the destination file or library object rather than import the new one.
- Select **Replace the existing macro with the imported macro** to delete the existing macro and replace it with the one being imported.
- Check **Do this for all remaining macro conflicts** to apply the same choice for any other macros with conflicting names in the current import operation.

If the program encounters a macro name conflict when importing into a library object or when placing a library object in a plan, a Question message box will ask if you wish to replace the existing macros. Click **Yes** to replace any existing macros with imported macros of the same name or click **No** to keep the existing macros and not import those of the same name.

---

## The Ruby Console



The Ruby Console can be used to access information about a variety of objects in Chief Architect Premier: information which can then be used to create custom Ruby macros. It can also be used to evaluate custom Ruby

macros to confirm that they are valid. See *Creating User Defined Macros on page 1387*.

Select **Tools> Ruby Console** to open the Ruby Console window. The Ruby Console can be open while you work using other tools in the program.

The Ruby Console interface is simple: at the bottom of the window is an Input field where you can type commands, and the results of your commands display in the Output field above.

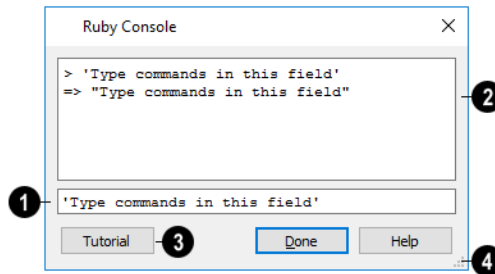

### 1 Command Input

Type expressions, or commands, in the Input field at the bottom of the window.

- Press Enter on your keyboard to enter your expressions and see the results.

Note: Chief Architect Premier uses Ruby 2.4.0.

### 2 Results

The results of your expressions display in the larger Output field, above.

- > at the beginning of a line indicates that what follows is your expression.
- => at the beginning of a line indicates that what follows is a result.
- As you type multiple expressions, they and the new results are added below the previous ones.
- Use the scrollbar on the right to scroll up and down the results field.

### 3 Tutorial

Click the **Tutorial** button to view an interactive written tutorial presented in the Ruby Console. See *Viewing the Interactive Tutorial on page 1401*.

### 4 Resize

Click the size grip and drag to resize the Ruby Console window as needed.

## USEFUL EXPRESSIONS

The following are a few commonly used expressions that you can use to obtain the attributes of one or more selected objects.

Macro	Description
<b>owner</b>	Returns the selected publisher
<b>selected</b>	Returns an array of multiple selected publishers
<b>referenced</b>	Returns the publishers



Macro	Description
<b>.names</b>	Preceded by owner, selected, or referenced, this returns an array of NVPs for the selected publisher (s).
<b>.&lt;variable_name&gt;</b>	Preceded by owner, selected, or referenced, this returns the value of the NVPs bounded by the brackets for the selected publishers(s).
<b>puts</b>	Returns a list instead of an array.
<b>\$</b>	Indicates a global variable rather than a local variable.

---

## Viewing the Interactive Tutorial

An introductory tutorial is included with Chief Architect Premier and can be run in the Ruby Console. To run it, select **Tools> Ruby Console** , then click the **Tutorial** button at the bottom of the dialog or simply type **show** in the Input field.

If you have previously run the tutorial during the current program session, the tutorial will open to the last topic shown. If you have not run the tutorial this session, its Table of Contents will open.

To view the tutorial's Table of Contents at any time, type **toc** in the Input field.

---

## Migrating Legacy Ruby Code

In Chief Architect Premier X11 and prior, Name-Value Pairs returned length, area, and volume measurements as Floats (or Integers, if rounded) instead of Measurements. When legacy Ruby macros or materials list formulas are evaluated in Version X15, the program will automatically check their version and provide an opportunity to migrate any instances of legacy Ruby code that it finds.

### MATERIALS LIST FORMULAS

A cell with a legacy formula is identified by an **Information**  icon. When the cell is moused over, its tool tip indicates the presence of a legacy formula, as well. See [Materials List Formulas on page 1320](#).

- Select the cell and click the **Migrate Formula** button to migrate the formula to use updated formatting.
- After migrating the formula but before deselecting the cell, you can also click the **Revert to Legacy** button to restore the original legacy formula. This button is only available until you click out of the cell.

### TEXT MACROS

Legacy Ruby macros are also identified by an **Information**  icon in the Text Macro Management dialog. When the icon is moused over, its tool tip indicates the presence of a legacy macro, as well. Select the macro and click the **Edit** button for further options. See [Text Macro Management Dialog on page 1396](#).

- In the Edit Text Macro dialog for a legacy macro, click the **Migrate Formula** button to migrate the macro to use updated formatting.
- After migrating the macro but before clicking OK in the Edit Text Macro dialog, you can click the **Revert to Legacy** button. This button is only available until you exit out of the dialog.

Backwards migration for formulas and macros is not supported.

## RUBY MIGRATION DIALOG

The **Migrate Formula** button is available in the Materials List when a cell with a legacy formula is selected. In the Edit Text Macro and Text Macro Management dialogs, it is available when a legacy macro is selected. Click this button to open the Ruby Migration dialog.

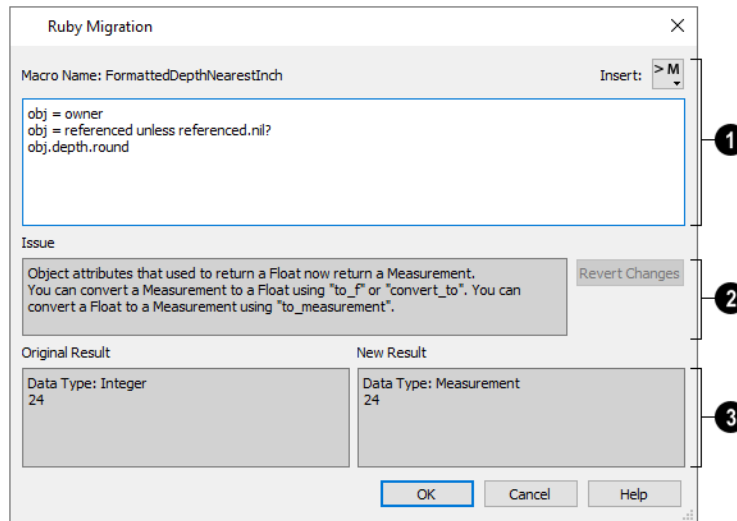

### 1 Macro

The legacy macro's name displays here for reference.

- The macro can be edited in the text field using the Ruby 2.4.0 programming language. NVP's, existing macros, and references to Ruby **.rb** files can be included.
- Click the **Insert** button above the text field to insert an already existing macro into the selected macro. See *To insert a macro on page 541*.

### 2 Issue

- The **Issue** that needs to be addressed by migration is described here for reference.
- If you make changes to the macro above and do not like the New Result below, click the **Revert Changes** button to restore the original value.

### 3 Results

These fields report Data Type and Value information when the selected macro is valid, or Evaluation Error information when it is not, for comparison purposes.

- The **Original Result** field reports information about the macro as it was when the dialog was first opened.
- The **New Result** field reports information based on changes made since the dialog was opened.

Click OK to return to the Text Macro Management dialog.

---

# Resources and Support

## Chapter 44

Chief Architect technical support, training, and other resources to help you be successful using our software.

### TOPICS

<b>Learning and Inspiration</b> .....	<b>1404</b>
<b>Training Services</b> .....	<b>1405</b>
<b>Contacting Technical Support</b> .....	<b>1405</b>
<b>Error Messages</b> .....	<b>1406</b>
<b>Program Paths Dialog</b> .....	<b>1407</b>

---

## Learning and Inspiration

Chief Architect offers a variety of resources that help you learn how to use the software, discover new drawing techniques, and connect with other Chief Architect users.

### CHIEF ARCHITECT WEBSITE



The Chief Architect website has an array of resources, including downloadable library content, program updates, news and events, and more. Select **Help> Visit Chief Architect Web Site** from the program menu to launch your default internet browser to [chiefarchitect.com](http://chiefarchitect.com).

### REFERENCE MANUAL



The Chief Architect Premier X15 Reference Manual is a comprehensive source of information about the entire program interface. This manual is available online in .pdf format by selecting **Help> View Reference Manual**.

### TUTORIAL GUIDE

Written for new Chief Architect users, but a helpful reference for users of all experience levels as well, the Tutorial Guide walks you through the process of creating a complete model, from the first wall to the interior design and landscaping.

This guide is available online by selecting **Help> View Tutorial Guide**.

 The Reference Manual and Tutorial Guide are available in printed form for optional purchase. For more information, visit [chiefarchitect.com](http://chiefarchitect.com).

### ONLINE HELP VIDEOS

Another resource that illustrates Chief Architect's tools is the collection of tutorial videos available on our website. To view the online videos, select **Help> View Online Help Videos** from the program menu or visit [www.chiefarchitect.com/videos](http://www.chiefarchitect.com/videos).

### ONLINE KNOWLEDGE BASE

The Chief Architect Knowledge Base is a collection of online articles that address common technical issues as well as a range of how-to questions with illustrations and step-by-step instructions. To access these resources, visit [chiefarchitect.com](http://chiefarchitect.com).

### CHIEFTALK ONLINE FORUM

The ChiefTalk Professional User Forum hosts ongoing discussion on a variety of topics related to the use of Chief Architect. It is rich with useful tips and available free of charge to all registered Chief Architect users.

- Discussions are initiated and carried out by users in a professional and friendly tone.
- Experienced users share knowledge with each other and beginners.
- Chief Architect Software team members post announcements, advice and technical information.

To visit ChiefTalk, select **Help> ChiefTalk** or go to [chieftalk.chiefarchitect.com](http://chieftalk.chiefarchitect.com).

## ONLINE SAMPLES GALLERY



A collection of plan sets, detail drawings, and renderings is available for viewing and download on our website. Select **File> Download Sample Plans** to launch your internet browser to [chiefarchitect.com](http://chiefarchitect.com).

---

## Training Services

Chief Architect offers a variety of online and in-person training opportunities. For details, schedules of upcoming events, and more, visit [chiefarchitect.com](http://chiefarchitect.com).

### ONLINE WEBINARS

Chief Architect regularly conducts live, online training seminars designed for different skill levels, and on a variety of topics. Learn the basics of using Chief Architect the right way by joining an Introductory series, then progress through topics of interest, such as Kitchens and Baths, Construction Documents, and Terrain.

### ON-SITE SEMINARS

Throughout the year, Chief Architect also conducts training seminars in various locations around the United States.

### PERSONAL ONLINE TRAINING

Conducted via telephone and high-speed internet, Personal Online Training lets you focus on your specific design challenges. With a Personal Trainer, it's fast and easy to meet your personal training needs from the comfort of your own computer.

---

## Contacting Technical Support

Chief Architect's world class technical support services can be accessed both online and by telephone. Select **Help> Technical Support** from the program menu to visit [chiefarchitect.com](http://chiefarchitect.com).

Before contacting Technical Support, take a moment to see if the answer to your question is found in the program's Help, Training Videos, or other online resources. When you contact us, you will be referred to these resources if the answer can be found there.

There are a number of things you can do to ensure a speedy answer to your question when you contact Technical Support.

- Select **Help> About Chief Architect (PC)** or **Chief Architect> About Chief Architect (Mac)** and make a note of the first characters of your Product Key and the program's Build number.
- We periodically release updates to the current program version. Before contacting Technical Support, select **Help> Download Program Updates** and make sure you are running the most current update for your program version.
- When you encounter an error message, click the **Send Report** button if possible and copy the message's exact wording. See *Error Messages on page 1406*.
- When calling Technical Support, have Chief Architect running on the computer where the problem occurs. This is necessary in order to troubleshoot the issue and verify that a solution is found.
- Be prepared to reproduce and describe the problem in detail. If we cannot reproduce the problem, there is a reduced chance that we will be able to resolve it.

## TELEPHONE SUPPORT

Our Technical Support team is committed to answering your questions as quickly as possible and in the order received. We can resolve most issues in just a few minutes and are happy to help you find the best resource to answer your questions. So that we can quickly answer all calls, though, we may ask that you limit your inquiry to one question.

Chief Architect X15 users who participate in the **Support and Software Assurance** program should use the Priority Support telephone number provided in their SSA documentation.

## ONLINE SUPPORT

If a Support technician needs to see a copy of a plan, layout, or other file, they will ask you submit it to us using the Chief Architect [Online Support Center](#).

Questions can also be submitted directly to the Technical Support department using the Online Support Center as well. Be sure to provide a detailed description of the problem you are encountering in your ticket.

---

# Error Messages

Most common error messages have a known cause and simple resolution. When you encounter an error or warning message in Chief Architect, you can click the **Check Knowledge Base** button in the message box to launch your default internet browser to the Chief Architect Knowledge Base on our website, [chiefarchitect.com](http://chiefarchitect.com).

If the message is discussed in an article it will display, providing information about the message and how best to avoid it.

It is important that abnormal errors be reported to Chief Architect Technical Support so that we can identify and resolve any problems.

The content of an error message is useful in diagnosing its cause. If you encounter an error message, make a note of the error number and the full text of the message. You can also click the **Details** button and copy the text into a text document or [Online Support on page 1406](#) Center ticket.

If you encounter the error more than once, make a note of your steps prior to receiving the message.

Finally, check to see if there are program updates available. Program updates contain enhancements and other changes that allow the software to perform at an optimum level. Select **Help> Download Program Updates** from the Chief Architect menu and follow the instructions on our website, [chiefarchitect.com](http://chiefarchitect.com).

## ERROR REPORTING

When an error occurs, you may have the option in the message box to send the report to Chief Architect by clicking the **Send Report** button in the error message box. A report containing technical details about the error, but no personal information, is sent to our Testing team for evaluation.

When you click the Send Report button, the **Automatically Send Error Reports** option will be enabled so that a report will be sent automatically should you encounter additional errors in the future. When Automatically Send Error Reports is enabled, error message boxes will not have a Send Report button. You can enable or disable Automatically Send Error Reports in the Preferences dialog. See [General Panel on page 102](#).

After clicking the **Send Report** button, please contact [Technical Support](#) with any additional information that you may have about the circumstances of the error: for example, the type of view that was open and the tool that was active.

---

## **Program Paths Dialog**

Some technical issues can be caused by problems with support files used by Chief Architect Premier. In the event of such an issue, Chief Architect Technical Support may direct you to the Program Paths dialog. This dialog displays a list of files utilized by the software along with the pathname of each.

To avoid unintended problems that could prevent you from using the software, it is strongly recommended that you make no changes to any of the files in this list except with the direct assistance of Technical Support.

---

# What's New in Chief Architect X15

## Chapter 45

Welcome to Chief Architect X15. This topic has been written to help our upgrading customers make a smooth transition from earlier versions of Chief Architect to Chief Architect X15.

### TOPICS

<b>Getting Started Checklist</b> .....	<b>1409</b>
<b>Migrating Legacy Content</b> .....	<b>1410</b>
<b>Migrating Legacy Settings</b> .....	<b>1410</b>
<b>Migrating Legacy Templates</b> .....	<b>1411</b>
<b>Considerations for Legacy Files</b> .....	<b>1411</b>
<b>New and Improved Features by Chapter</b> .....	<b>1419</b>



---

## Getting Started Checklist

There are many new features in Chief Architect X15, and many existing features have changed. The following list suggests steps you should take before migrating your files to Chief Architect X15. More information about each of these steps can be found after the list.

### 1. Review the List of New and Improved Features by Chapter

There are a number of important reasons why you should familiarize yourself with the new and improved features in Chief Architect X15:

- New and improved features allow you to produce drawings more efficiently, so it is to your advantage to use them.
- Some changes to existing functionality may affect your accustomed drawing style and thus your productivity if you are not aware of them.
- New features may affect your choice of settings in your template files, as well as your preferred Preferences settings.

See *New and Improved Features by Chapter on page 1419*.

### 2. Review Migrating Legacy Content

Legacy users of Chief Architect often have library catalogs and other custom content that they want to continue using. See *Migrating Legacy Content on page 1410*.

### 3. Review Migrating Legacy Settings

Before migrating Preferences, Toolbars, or Hotkeys, bear in mind that legacy settings may not be best suited for using the new program version. See *Migrating Legacy Settings on page 1410*.

### 4. Review Migrating Legacy Templates

Before migrating Templates, bear in mind that they may not be set up to take advantage of new tools in the new program version. See *Migrating Legacy Templates on page 1411*.

### 5. Review the Considerations for Legacy Files

Before opening a plan or layout file created in a previous version of Chief Architect, be aware of potential changes to the file that could occur in the new program version. See *Considerations for Legacy Files on page 1411*.

### 6. Launch Chief Architect X15

Once you have learned about the new features in Version X15 and decided whether to migrate any custom settings from a legacy program version, launch Chief Architect X15. The first time you launch, the Migrate Settings dialog will give you the opportunity to bring legacy settings and content forward into Version X15.

---

## Migrating Legacy Content

Legacy users of Chief Architect Premier often have a wealth of library catalogs and other custom content that they have built over time and want to continue using.

### LEGACY LIBRARY CONTENT

There are several ways that legacy library catalogs can be brought into Chief Architect X15.

If you have Chief Architect version X5 through X14 installed on your computer, the Migrate Settings dialog will display after you activate the license, allowing you to migrate library content as well as a selection of other settings for use in Chief Architect X15. If multiple legacy versions are present on the system, only the data associated with the most recent will be migrated.

You can import library files from Versions X1 through X5 at any time by selecting **Library > Import Library (.calib, .calibz)** from the program menu.

In addition, library files from Versions 10 and prior can be imported by selecting **Library > Convert Legacy (.alb) Library Files** from the program menu. Bear in mind, though, that older content may not be of the same quality as currently offered catalogs and that legacy Manufacturer catalogs may be out of date.

### CUSTOM GRAPHICS FILES

Chief Architect can use graphics files regardless of where they are stored on your system; however, it is a good idea to keep your data organized in one location. If you have custom graphics files, including textures, images or backdrops that you used in a previous program version, you can copy them manually using your operating system for use in Chief Architect X15.

- Copy custom texture files to the Chief Architect X15 Textures folder located in the Chief Architect X15 Data folder.
- Copy custom image files to your Chief Architect X15 Images folder located in the Chief Architect X15 Data folder.
- Copy custom backdrop files to your Chief Architect X15 Backdrops folder located in the Chief Architect X15 Data folder.

In Chief Architect X1 through X14, custom graphics were saved in the Chief Architect Data folder, as they are in version X15. In version 10, they were located in the program's installation directory, in folders that began with "My". Custom backdrops, for example, were saved in "My Backdrops".

Texture and image files are not listed in the Library Browser. These files can be assigned to material and image objects, however, which are stored in the library so it is important to retain them. There are several tools available for adding materials and images to the library.

---

## Migrating Legacy Settings

The Migrate Settings dialog lets you migrate settings from the most recent legacy installation of your Chief Architect title into Version X15. If you have extensively customized your Preferences, Toolbars, or Hotkeys, you may want to continue using those settings. Before doing so, though, it is important to consider that you may make it harder to take advantage of new tools and functionality in Version X15.

## PREFERENCES SETTINGS

Although you can migrate your Preferences settings from Versions X5 through X14 into Version X15, the settings that are available in Version X15 may differ from previous program versions. You should review all the settings in the Preferences dialog to make sure that they are set to suit your drawing needs.

## CUSTOM TOOLBAR CONFIGURATIONS

It is possible to migrate toolbar configuration files from previous program versions into Version X15; however, it is also possible that your migrated toolbars will be missing new tools available in Version X15.

Additionally, obsolete toolbar buttons are occasionally removed from the program and will also be removed from migrated legacy toolbars. See *New and Improved Features by Chapter on page 1419* for information about new features as well as removed or deprecated tools.

## CUSTOM HOTKEYS

Like toolbar configurations, legacy hotkeys can be migrated into Chief Architect Premier X15. Bear in mind, though, that occasionally the default hotkeys are modified to accommodate new features or changes in default system hotkeys.

---

# Migrating Legacy Templates

Chief Architect X15 installs a selection of template plan and layout files that have been set up to take advantage of the program's updated tools and features. Although you can migrate your template files for use in Version X15, for best results it is recommended that you either:

- Use the installed templates when creating new plans and layout files in Chief Architect X15
- Use the installed templates as the basis for creating new custom templates.

If you choose to continue using template files that you used in a previous program version, it is very important that you take the time to review all the default settings in the file, making sure that they will continue to suit your needs in Version X15. See *New and Improved Features by Chapter on page 1419*.

Next, make sure that you are aware of changes in Version X15 that may affect legacy files: including templates. See *Considerations for Legacy Files on page 1411*.

When you are ready to proceed, make copies of your custom templates in the Chief Architect X15 Templates directory. The Templates directory is located in the Chief Architect X15 Data folder. Next, open each template as you would a regular plan or layout file, by selecting **File> Open**, and then save any changes you make by selecting **File> Save**.

If you do choose to continue using a legacy template plan, it is best to also use a legacy layout template from the same program version, as well. As with a template plan, take the time to go through the layout template's defaults and make sure they are suited for use in Version X15 and that their line weight scales do not conflict with those in your template plans.

---

# Considerations for Legacy Files

As in all software, every new program version introduces changes to its functionality as well as to the user interface. If you choose to bring a project forward, be sure to take a few moments to look it over in the new version and confirm that the new functionality does not require you to make any modifications. Particularly if you have an approaching deadline, you may find it best to finish the current project in the version of the software in which you began it.



Be sure to read this section before opening any plans created in earlier versions of Chief Architect.

Chief Architect X15 can open the **.plan** and **.layout** files from prior versions. Files with the older **.pl** and **.la** file extensions are no longer supported, however, and cannot be opened by Chief Architect X15. Before opening any files created in earlier versions of Chief Architect, it is important to be aware of changes made in the newest version and the effect they may have on your legacy plan and layout files.

Please note that files saved in the latest program version cannot be read by older versions of the software. When a legacy file is saved in the version X15, an unaltered copy of the original file is created in the Chief Architect X15 Data folder, under Archives, which can still be opened in the original version.

### **FOR FILES CREATED IN VERSION X14 AND PRIOR**

In addition to the above recommendations, if you wish to open files created in Chief Architect Version X14 or prior, bear in mind the following:

1. Window Casing Reveal

In Chief Architect X14 and prior, window casing had an Overlap Frame setting that controlled where casing was placed relative to the window frame, and windows with different frame Width values for their top, bottom, and sides would also have different reveals. In Version X15, this setting was replaced with a Reveal setting. When a legacy file is opened in Version X15, any windows with different Width values will no longer have different reveals.

2. Text Indent and Margins

In Chief Architect X14 and prior, the indent and margins of text could vary depending on the font used. In Version X15, indent and margins are not affected by settings in the font. When a legacy file is opened in Version X15, text with varying indent and/or margins may be affected.

### **FOR FILES CREATED IN VERSION X13 AND PRIOR**

In addition to the above recommendations, if you wish to open files created in Chief Architect Version X13 or prior, bear in mind the following:

1. Stair Walk Lines

In Chief Architect X13 and prior, Walk Lines were drawn on the "Dimensions" layer. In Version X14, they are drawn on the same layer as the staircase. When a legacy file is opened in Version X15, any Walk Lines displaying in the file may have different line color, weight, and style attributes.

2. Door Rough Openings

In Chief Architect X13 and prior, if a door's Floor to Bottom height was not sufficient to accommodate its Bottom Rough Opening, the door's Top Rough Opening space would be increased in the model but not in the Door Specification dialog. In Version X14, this no longer occurs: if the Floor to Bottom height is less than the Bottom Rough Opening, the full Bottom Rough Opening is simply not modeled when framing is generated. When a legacy file is opened in Version X15, its rough opening is modeled exactly as it was in the previous program version but its Top and Bottom Rough Opening values now reflect how the rough opening is modeled.

3. NKBA Auto Dimensions

In Chief Architect X13 and prior, the NKBA Auto Dimension and NKBA Auto Elevation Dimension tools had restricted default settings that met drawing standards set by the National Kitchen and Bath Association. In order to allow greater flexibility in Version X15, these tools have been merged into the other Auto Dimension tools. In plan files created using

a template installed with Version X15, NKBA compliant dimensions can be created using the "Kitchen and Bath Dimension Defaults". In legacy plans opened in Version X15, use the "Legacy NKBA Dimension Defaults".

## FOR FILES CREATED IN VERSION X12 AND PRIOR

In addition to the above recommendations, if you wish to open files created in Chief Architect Version X12 or prior, bear in mind the following:

### 1. Default 110V Ceiling Outlet

In Chief Architect X12 and prior, the 110V Outlet tool did not have the ability to place outlets in ceilings. In Version X13, this ability was added, as was the new GFCI Outlet tool. When a legacy file is opened in Version X15, the new Electrical Defaults settings for these items will automatically refer to objects in the Version X15 Core Catalogs. You should confirm that these defaults meet your needs. If these default objects are not present in your library, a warning message will inform you of the issue.

### 2. Sliding Door Hinge Side

In Chief Architect X12 and prior, the fixed or 'hinge' side of sliding doors was described as viewed from the exterior side of the door. In Version X13, the hinge side is described using the more common method: as viewed from the interior side. When a legacy file is opened in Version X15, all instances of the %hinge\_side% Name-Value Pair in labels, schedules, and the Materials List will use the new method. You should confirm that the Hinge Side information in labels, schedules, and Materials Lists meets your needs.

### 3. Automatic and Manual Dimension Layers

In Chief Architect X12 and prior, the system default layer for automatically generated dimension lines was "Dimensions, Automatic", and the system default for manually drawn dimensions was "Dimensions, Manual". In Version X15, the system default layer for all dimensions is simply "Dimensions". When a legacy file is opened in Version X15, automatic dimensions that were on the "Dimensions, Automatic" layer in the earlier version will be placed on the "Dimensions, Legacy" layer while any dimensions that were on the "Dimensions, Manual" layer in the previous version will be placed on the "Dimensions" layer.

### 4. Gable Lines

In Chief Architect X12 and prior, Gable Lines with a Pitch value of 90° were allowed but did not affect automatic roof generation. In Version X15, they are not supported. When a legacy file is opened in Version X15, any Gable Lines with a Pitch of 90° will be removed automatically. This will not affect the current roof or automatic roof generation.

## FOR FILES CREATED IN VERSION X11 AND PRIOR

In addition to the above recommendations, if you wish to open files created in Chief Architect Version X11 or prior, bear in mind the following:

### 1. Perspective Crop Mode

In Chief Architect X8 through X11, Perspective Crop Mode allowed older functionality governing zooming in cameras from Version X7 and prior to be preserved in saved cameras in legacy plans migrated forward. This deprecated tool has been removed from the program's menu and toolbars in Version X12, although it can be migrated with legacy toolbars and hotkeys. Saved cameras in legacy plans with this behavior enabled may become distorted if you pan or zoom in the view. To permanently disable this behavior in a camera view and resolve the resulting distortion, select **Window> Fill Window** or press the F6 key.

### 2. Layout Layer Sets

In Chief Architect X11 and prior, the Send to Layout dialog had a sticky Make Copy of Active Layer Set option that created a new layer set for the layout view to help preserve layer settings in that view. This option was removed in

Version X12 to encourage use of the multiple saved plan views. Saved plan views did not exist in Version X9 and prior, however, so if you open a plan originally created in Version X9 or prior, extra care must be taken to make sure layout views do not use the same layer set.

### 3. Materials List Formulas and Ruby Macros

Name-Value Pairs returned length, area, and volume measurements as Floats. In Version X12, these values are reported using the Measurement class that includes both a numeric value and a unit. Older Ruby code may change behavior when migrated into Version X12. When a legacy Ruby macro or materials list formula is evaluated, the program will automatically check its version and prompt you to migrate it to the newest version.

### 4. Units of Measurement

In Chief Architect X11 and prior, units of measurement used by the program, including user-defined units, were stored in a file called Units.dat located in the Chief Architect Data folder. Beginning in version X12, this information is saved with other Preferences settings.

## FOR FILES CREATED IN VERSION X10 AND PRIOR

In addition to the above recommendations, if you wish to open files created in Chief Architect Version X10 or prior, bear in mind the following:

### 1. Marker and Elevation Point Heights

In Chief Architect X10 and prior, the # sign could be added to the label of a Marker or Elevation Point and the label would report the height of the Marker or the Elevation Point's elevation. In Version X15, text macros are used to report this information instead. In legacy plans, any # signs in Marker or Elevation Point labels will be replaced by the %height% or %elevation% macro.

### 2. Glass Shower Walls

In Chief Architect X10 and prior, the "Glass Shower" wall type was included in installed template files and like other wall types, built to the structural layer of floors and ceilings and to the Main Layer of adjacent walls. In Version X15, this wall type has the new Partition Wall attribute and instead builds to floor, ceiling, and wall surfaces. When a legacy file is opened in Version X15, this wall type will be modified to have Partition Wall checked automatically and existing walls will be affected by this change.

### 3. Fixture Schedules

In Chief Architect X10 and prior, 3D Elevations and Perspectives in Fixture Schedules showed cabinet fixtures inserted into a cabinet. In Version X15, fixtures are shown on their own, even when they are inserted into an object in the plan. When a legacy file is opened in Version X15, any fixture schedules showing 3D views of objects may be affected by this change.

## FOR FILES CREATED IN VERSION X9 AND PRIOR

In addition to the above recommendations, if you wish to open files created in Chief Architect Version X9 or prior, bear in mind the following:

### 1. Parallel Lights

In Chief Architect X9 and prior, Parallel Light sources could be specified for electrical light fixtures and Added Lights. In Version X15, Parallel Lights are no longer supported. In legacy plans opened in Version X15, any Parallel Light sources will be converted to Spot Lights.

### 2. Brick Ledges

In Chief Architect X9 and prior, brick ledges were not represented in plan view. In Version X15, brick ledges are drawn in plan view on the “Slabs” layer in stem wall and grade beam foundations, and on the “Walls, Foundation” layer in monolithic slab foundations. When a legacy file is opened in Version X15, brick ledges, if present, will be drawn.

### 3. Window Types

In Chief Architect X9 and prior, the %type% text macro for windows reported some Window Types using abbreviations. In Version X15, the abbreviations were replaced with full words. When a legacy file is opened in Version X15, the width of Window Schedules may be affected, as may the width of columns in saved Materials Lists.

### 4. Joist Direction Lines

In Chief Architect X9 and prior, Joist Direction Lines described all platform framing as “joists” and used nominal lumber sizes in whole inches in US Unit plans. In Version X15, the platform’s framing Structure Type is reported and in US Unit plans, the size is described in fractional inches. When a legacy file is opened in Version X15, Joist Direction Lines will use the new, more accurate labeling.

### 5. Custom Schedule Columns

In Chief Architect X9 and prior, custom schedule columns could be created by adding a Sub Category to a type of object on the Categories panel of the Preferences dialog. In Version X15, Sub Categories can no longer be created in this manner. When a legacy file is opened in Version X15, any Sub Categories shown as custom schedule columns will be converted to Custom Fields.

### 6. Registered User Text Macros

In Chief Architect X9 and prior, a selection of Registered User Text Macros could be inserted into Texts, Callouts, and Markers. These macros no longer displayed any data and in Version X15, they are no longer recognized. When a legacy file is opened in Version X15, any Registered User macros inserted into text objects are treated as regular text.

## FOR FILES CREATED IN VERSION X8 AND PRIOR

In addition to the above recommendations, if you wish to open files created in Chief Architect Version X8 or prior, bear in mind the following:

### 1. Layer Names

In Chief Architect X8 and prior, turning off the Modify Name in all Layer Sets option made it possible to assign different names to the same layer in different layer sets. In Version X9, this option was no longer supported. When a legacy file is opened in X15, the layer names used in the currently active layer set will be retained and any other layer names in other layer sets will be discarded.

## FOR FILES CREATED IN VERSION X7 AND PRIOR

In addition to the above recommendations, if you wish to open files created in Chief Architect Version X7 or prior, bear in mind the following:

### 1. Boxed Eaves

In Chief Architect X8, improvements to the generation of Boxed Eaves ensure that they extend into exterior rooms with “Use Soffit Surface for Ceiling” specified when located between the roof baseline and an interior room. In some legacy plans opened in Version X15, the **Length** value for Boxed Eaves may need to be modified in the Roof Plane Specification dialog.

### 2. Uppercase Text

The Uppercase option was added to Text Styles in Version X8, whereas in Version X7 and prior, it was an option for Room Labels and Schedules only. In legacy plans opened in Version X8, any Schedules present in the drawing will be assigned a Custom Text Style, as will their associated Schedule Defaults. If any Schedule Default is set to Use Layer for

Text Style and no objects are present on that layer, a new Schedule Text Style will be created and assigned to that layer. Room Labels are treated similarly: if any are present, they and their defaults will use a Custom Text Style. If a given Room Label or Schedule has been sent to layout more than once and was set to use different Text Styles in each layout view, it is possible that its appearance may be affected in some views.

### **FOR FILES CREATED IN VERSION X6 AND PRIOR**

In addition to the above recommendations, if you wish to open files created in Chief Architect Version X6 or prior, bear in mind the following:

1. Built-in Appliances

In Chief Architect X6 and prior, some appliance symbols designed to be inserted into base cabinets had incorrect sizing data. In legacy plans opened in Version X15, these appliances will not fit into the cabinet correctly and will need to be replaced. Built-in dishwashers are particularly affected.

2. Formatting of Bulleted and Numbered Lists

In Version X7, various improvements were made to the way lines of Rich Text are spaced. In legacy plans opened in Version X7, Rich Text objects with bulleted and numbered lists may require adjustments.

3. Chief Blueprint Font

The Chief Blueprint font was improved for Version X6, with decreased top and bottom spacing. The change in spacing may increase the overall height of text objects using this font in X6 files opened in Version X15. X5 and prior legacy files will not be affected by this change.

### **FOR FILES CREATED IN VERSION X5 AND PRIOR**

In addition to the above recommendations, if you wish to open files created in Chief Architect Version X5 or prior, bear in mind the following:

1. Name-Value Pairs for Doors and Windows

In Version X6, the NVPs `door_style_name`, `door_type_name`, and `window_type_name` were shortened to `style_name` and `type_name`. Any object labels or text macros using these NVPs in legacy plans opened in Version X15 will need to be replaced.

### **FOR FILES CREATED IN VERSION X4 AND PRIOR**

In addition to the above recommendations, if you wish to open files created in Chief Architect Version X4 or prior, bear in mind the following:

1. Roof Overhangs and Framing

In Chief Architect X4 and prior, roof overhangs were measured to the outside of the subfascia, whereas in Version X5 and later, they are measured to the outside of the fascia or shadow boards, if present. In legacy plans opened in Version X15, this will not affect the appearance of roof planes in floor plan view because in X4 and prior, roof plane polylines represented the projected framing area whereas in Version X15 they represent the total projected area. But, the position of the fascia and subfascia will shift, as will the length of the rafters.

2. Door Swing Direction and Materials

In Chief Architect X4 and prior, exterior doors that swing outward displayed the interior material on the exterior side of the door. This was corrected in Version X15. Doors modified to work around the old behavior could be affected in legacy plans opened in Version X15.

3. Door Swing Direction and Louvers



Improvements to door louver direction may affect louvers in all doors with the exception of bifold doors.

#### 4. Wrapped Door/Window Lintels and Window Sills

In Chief Architect X4 and prior, wrapped lintels and sills extended out further than those that were not wrapped. In legacy plans opened in Version X15, the extents of wrapped lintels and sills will be adjusted so that they equal their **Extend** setting.

#### 5. Cabinet Feet

The offsets for cabinet foot millwork symbols in Version X4 and prior were set per millwork symbol to insert into cabinets effectively. In Version X15, the offset is set in the Cabinet Specification dialogs. When legacy plans are opened in Version X15, cabinet foot offsets are set to 0 and transferred to their containing cabinet, if one exists. Any customized or independently placed cabinet feet will be affected.

#### 6. Object Labels in Cross Section/Elevation Views

If a “Label” layer is turned on in a cross section/elevation view and objects of that type are visible in the view, then those objects’ labels will display in that view when the plan is opened in Version X15.

#### 7. Transparent Materials

In Chief Architect X4, materials assigned to the Transparent Material Class for ray tracing were visible in rendered views even when their Index of Refraction was set to 1.0. When legacy plans are opened in Version X15, Transparent materials with an Index of Refraction of 1.0 are transferred to the General Material class and assigned a Transparency value of 100%. This will not affect these materials’ appearance in ray trace views, but will make them completely invisible in rendered views.

#### 8. Registered User Text Macros

In Chief Architect X4 and prior, a selection of Registered User Text Macros could be inserted into Texts, Callouts, and Markers. These macros reported information that was provided when the program was installed and registered on the computer. In Version X5 and later, the program no longer collects registered user information. When a legacy file is opened in Version X15, any Registered User macros inserted into text objects are treated as regular text.

#### 9. Invisible Beams

The legacy **Invisible Beam** check box was removed from the Wall Specification dialog. When legacy plans are opened in Version X15, any **Invisible Beam** walls will be converted to Invisible Walls.

### FOR FILES CREATED IN VERSION X3 AND PRIOR

In addition to the above recommendations, if you wish to open files created in Chief Architect Version X3 or prior, bear in mind the following:

#### 1. Text Styles

The appearance of a number of objects that include text - including object labels, the North Pointer, Sun Angles, Joist Direction Lines, the Up/Down arrows for stairs and ramps - can now be controlled using Text Style. Their appearance may be altered somewhat in legacy plans opened in Chief Architect X15.

#### 2. Light Sources

The illumination created by light fixtures and Added Lights was improved in Chief Architect X15. Lighting in legacy plans may appear noticeably brighter when viewed in version X15.

### FOR FILES CREATED IN VERSION X2 AND PRIOR

If you wish to open files created in Chief Architect Version X2 or prior, bear in mind the following file management changes and structural enhancements:

1. Legacy file formats

Chief Architect9.5 and prior files were saved in .pl and .la the file formats. These file formats files are no longer supported and cannot be opened in version X15.

2. Material textures, images, and backdrops

Chief ArchitectX2 and prior installed with a catalog of library content, including a selection of material textures, images, and backdrops. This library catalog is no longer installed with the program because it is now available for download on-demand, so it will be possible to open a legacy plan in version X15 and encounter numerous missing file warnings. To avoid this, we recommend using the **Export Entire Plan** feature in the original program version to create a folder that includes the plan and all associated textures, images, and backdrops before opening this file in X15. This tool is renamed Backup Entire Plan in version X15.

3. Floor and ceiling finish thicknesses

In Chief Architect X2 and prior, floor and ceiling finish layers were not modeled in 3D, and objects such as railings, stairs, landings, cabinets, fixtures, and furnishings measured their Floor to Bottom height from the subfloor. These objects now measure their Floor to Bottom height from the floor finish surface by default, so it is possible that you may notice height changes for these objects - particularly in saved, annotated cross section/elevation views.

4. Riser heights and landing thicknesses

The default Best Fit Riser Height for stairs that do not reach the next level has been updated from 9" (225 mm) in version X2 and prior to 6 3/4" (169 mm) in Chief Architect X15. This may affect the riser heights of stairs, as well as the thicknesses of landings attached to those stairs.

5. Auto Adjust Height

The Follow Terrain option in some specification dialogs was replaced by the Auto Adjust Height check box. If a cabinet, fireplace, fixture, furniture, or other library symbol had Follow Terrain unchecked in version X2 or prior and was located in a room with a floor height other than the default for the current floor, then the object's Floor to Bottom Height will change to equal that room's floor height. The object's position in the model will not change, however.

6. Adjustable Thickness Walls

In Chief Architect X2 and prior, generic, single-layer wall types were available for use. When a legacy plan file is opened in version X15 and these wall types are detected, they are replaced by an updated, non-generic wall type. Framed walls and Railings will also acquire 1/2" (13 mm) thick layers of sheetrock on each side. Railings that define a Deck room with Advanced Deck Framing Built will not acquire sheetrock layers.

7. Stairwells defined by railings

Interior railings that used a generic, single-layer wall type drawn in older program versions will acquire layers of sheetrock when the plan is opened in version X15. This can affect the appearance of staircases where they join to a floor platform. To address this issue, select the railing and move it 1/2" (13 mm) away from the top edge of the staircase.

8. Deck rooms

In legacy plans opened in Chief Architect X15, Deck rooms with Advanced Deck Framing built retain the framing but have Automatic Deck Framing turned off by default. Decks with no Advanced Deck Framing built are converted to Balcony rooms.

9. Material definitions and light sources

Settings in the Define Material dialog that affect materials' appearance of brightness have been modified. The **Ambient** setting was removed, and the **Diffuse** setting for materials in legacy plans will be set to 100% when opened in version X15.

The Quality setting for light sources set to use Soft Shadows in ray tracing was also modified. Lights using Soft Shadows in legacy plans will be set to use Medium quality. The Light Diameter of light sources in legacy plans is capped at 4" (100 mm).

10. Structural Member Reporting

When a plan created in Chief Architect X2 or prior is opened in Chief Architect X15, Materials Lists are set to calculate **Total Linear Length**. For a combination of linear length and piece count, select **Mixed Reporting** in the Structural Member Reporting dialog.

11. Fill New Framing Members

In Chief Architect X2 and prior, Fill New Framing Members was view-specific; in Chief Architect X15 it applies to the entire plan. As a result, it is turned off by default in legacy plans opened in version X15.

---

## New and Improved Features by Chapter

The following is a list of new and improved features in Premier Version X15. Where possible, cross-references to additional information has been provided.

### PROJECT PLANNING

- The Reference Plan can be offset along the X, Y, and Z axes as well as rotated in plan and camera views.
- Entries in the Time Log dialog can now be group-selected.
- The entries in the Time Log dialog can no longer be sorted by column.

### PREFERENCES AND DEFAULT SETTINGS

- **Save Dialog Size** and **Save Dialog Position** are now separate settings in the Preferences dialog.
- New **Double-Click Closes Browser** option can be unchecked to prevent the Library Browser and any side windows it is docked with from closing when a library item is double-clicked in the Filter Results panel.
- New **Reset** button for View Colors in the Preferences dialog.
- When a non-default User Catalog location is specified, you can now choose whether to copy the old folder's contents to the new location.
- Access to the **Default Designer Information** was moved to the NEW PLANS panel of the Preferences dialog.
- New options in the Preferences dialog for copying **Designer/Client Information** from Templates into new files.
- The obsolete Turn on Connect Island Rooms When Opening Legacy Plans setting was removed from the Preferences dialog.

### TOOLBARS AND HOTKEYS

- New **2D** and **3D Smooth Acceleration** settings in the Gamepad Setup dialog control the speed at which acceleration and deceleration occur.
- Toolbars can now be added to the Dashboard.

### WINDOW AND VIEW TOOLS

- Three new **Coordinate System Indicators** can be set to display in various view types.
- The **Saved Plan View Control** is now available in the Chief Architect desktop Viewer software.

## CREATING OBJECTS

- Improved **Object Snaps** in cross section/elevation views.

## DISPLAYING OBJECTS

- New tools for creating and editing custom **Patterns** .

## EDITING OBJECTS

- New **Select Next Side**  edit button for architectural objects in 3D views.
- The Point to Point Move edit tool can now use Allowed Angles.
- The Trim Object(s) and Extend Object(s) edit tools are now available for trusses.
- Closed Polylines can now be converted to Terrain Modifiers.



## CAD OBJECTS

- The Sun Angle and North Pointer tools are no longer child tools of the CAD Line Tools parent and are now found in the main CAD menu.
- CAD Insulation Boxes can now be assigned fill.
- Custom arrowhead styles can now be created using CAD blocks.
- CAD blocks can now be assigned labels.
- Editing the name of a CAD block as displayed in the Library Browser will now update the name of the block itself.
- New **Add Insertion Point**  option available in CAD Block windows.
- CAD Details in layout files have been deprecated: they can still be present in legacy layout files but cannot be created in new ones.

## WALLS, RAILINGS, AND FENCING

- New **Extension** setting for the bottom edge of exterior wall layers.
- Obsolete Connect Island Rooms check box has been removed from the General Wall Defaults dialog.
- Newel posts now have a **Bottom Offset** setting.
- New **Horizontal Offset** setting allows you to offset a railing relative to the floor platform edge it defines.
- Railings now have **Horizontal** and **Vertical Offset** options for rails. See [Rails Panel on page 410](#).
- The Wall Type Definitions now features a tabbed interface along with its wall layer table.
- New **Insert Floor Framing Below** setting in the Wall Specification dialog controls whether extra support trusses are generated under a selected wall.
- New **Include Automatic End Truss Above** setting in the Wall Specification dialog supplies the Attic wall above with an end truss instead of framing.



## ROOMS

- Island rooms no longer require an invisible Room Divider to connect them to other walls in a structure.
- Size information about the selected room or rooms is now reported in the Room Specification dialog.
- New **Turn Off Ceiling**  and **Turn On Ceiling**  edit buttons.

## DIMENSIONS

- Dimension lines can now locate closed cabinet doors, drawers, and panels in plan view.
- Dimension lines can now locate molding edge profiles on countertops.

## TEXT, CALLOUTS, AND MARKERS

- Callout arrows now have a **Transparency** setting.
- New **Replace Fonts**  tool.
- **Hyperlinks**  can now be inserted into Rich Text.
- The Diameter, CenterLine and Square Foot symbols can now be inserted into text as Special Characters.
- Indent and Margin values will now be an exact distance that will no longer vary between fonts.

## DOORS AND WINDOWS

- The Overlap Framing setting for window casing has been replaced with the **Reveal** setting like doors have.
- New **Panel Size** settings let you set the height of a door panel independent of its jamb.
- Door handles can now be resized and rotated in the Door Specification dialog.
- New **Door Size Includes Jamb** and **Door Size Excludes Jamb** options in the Door Specification dialog.
- New **Window Size Includes Frame** and **Window Size Excludes Frame** options in the Window Specification dialog.
- Corner windows on both sides of a wall are now fully supported.
- Interior window treatments are now drawn on the "Windows, Blinds & Curtains" layer.
- Lintels can now be assigned to arched windows with Reflect Vertically specified.
- Arches can now be assigned to all door and window types with the exception of symbol windows.
- Door and window rough openings can now be defined in terms of **Additional Space** or **Clearance Gap**.
- Improved how door frames are modeled for doors in curved walls.
- Include Top Sill can now be unchecked when Vertical Placement is set to Top of Wall.

## CABINETS

- New **Make Cabinet Molding Polyline**  edit tool.
- Automatic cabinet end panels can now display in plan views.
- Cabinet hardware can now be **Centered** both horizontally and vertically on doors and drawers.
- New **Display Molding Edges in Plan Views** setting in the Base Cabinet Specification dialog allows countertop edge profiles to be represented in plan view.
- Pilasters can now be set to display in plan view.
- New **Placement** options for Cabinet Corner Treatments.
- Corner pilasters are now specified on the BOX CONSTRUCTION panel of the Cabinet Specification dialog.
- New **Left** and **Right** placement options for **Front Pilasters**.
- Partitions now have **Toe Kick** settings.
- Shelves and Partitions now have the **Suppress Adjacent Room Moldings** option.

## ELECTRICAL

- The light sources assigned to Light symbols are now listed in a table rather than a drop-down list in the Electrical Service Specification dialog.
- Switches, Outlets, and Lights have a new **Connect Electrical** edit handle that allows you to draw a Connect Electrical spline.
- The Position Indicator of the selected light source now displays in the preview pane in the Electrical Service Specification dialog.
- Rope Lights now **Center Lights** along the length of each rope light by default.

## SCHEDULES AND OBJECT LABELS



- The Schedule Specification dialog now has a NUMBER FORMATTING panel that lets you set how numbers in each column are formatted.
- New Callout Symbol column displays each line item's schedule callout label, including the shape.
- Schedule rows can now be sorted by column in either ascending or descending order in the Schedule Specification dialog.
- The colors of Callout Symbols, 2D Symbols, 3D Elevations, and 3D Perspectives can now be drawn **From Plan** or **From Schedule**.
- A minimum number of schedule rows can now be specified.
- New schedule columns:
  - Header Height for windows and doors
  - Percent Openings (Energy) for walls
  - Volume for rooms
  - Requirements for fixtures
  - Type for fixtures, furniture, and millwork
  - Door Style and Drawer Style for cabinets
- 3D preview columns are now available for framing and trusses in schedules.
- Multiple Schedule Defaults can now be selected in the Default Settings dialog.

## STAIRS, RAMPS, AND LANDINGS

- The radius of curved stairs can now be specified.
- Stairs, Ramps, and Landings now have a railing **Horizontal Offset** option in their specification dialogs.
- Stair, Ramp, and Landing newels now have a **Bottom Offset** setting and an option for newel bottoms to be **Clipped** at the floor surface.

## ROOFS

- Individual roof planes as well as automatic Dormers now have a **Framing Method** option in their specification dialog that lets you select either Trusses or Rafters.
- The Skylight check box has been removed from the Skylight Specification dialog.
- New **Roof Hole**  tool.
- Skylight frames can now display in plan view.

- New Skylight **Shape** options: Rectangle, Circle, Ellipse, and Oval, as well as an object preview, in the Skylight Specification dialog.
- Skylight shape can no longer be modified using edit handles.
- New **Edit Skylight Shape**  edit tool.
- The **Set as Default** edit button is now available for automatic dormers.
- The Automatically Place Roof Intersection Points option in the Preferences dialog has been removed in favor of the new **Place Roof Plane Intersection Point**  edit tool for a selected roof plane.
- New **Heel Height** setting and improved interface for Roof Height settings in the Build Roof dialog.
- New Auto Resize Window option in the Dormer Specification dialog can be unchecked to prevent dormer windows from resizing.
- New **Create Shaft to Room Below** option in the Dormer Specification dialog creates an opening in the floor platform below a dormer to the floor below, and encloses the inside of the dormer with walls.

## FRAMING AND TRUSSES

- Roof and Floor/Ceiling Trusses can now be generated automatically.
- Ceiling framing no longer generates automatically where roof trusses are present.
- New "U Shaped" framing configuration for Wall Corners.
- New check box for Ridge beams allows you to generate them or not.
- New **Include Ridges** check box lets you control whether sloped ceiling planes receive ridge boards when roof framing is generated.
- Trusses can now be deleted from a plan in the Truss Detail.

## TRIM AND MOLDINGS

- Railings now have Horizontal and Vertical Offset options for rails.

## THE LIBRARY

- Redesigned Library Browser side window.
- Custom **Tags** let you organize items into categories for efficient searching and filtering.
- Chief Architect now checks for catalog updates automatically and identifies catalogs with new content.
- The Library Browser's Search function now includes online content.
- New **Go Back** and **Go Forward in History** buttons let you navigate your library search history.
- New **Restore** option lets you retrieve items in the Trash and place them back in the User Catalog.
- New **Vacuum** option lets you remove data associated with deleted content from the library database.
- Up to 398 instances of the Place Library Object button can now be used at a time.
- Duplicate items are now identified when content is imported into the User Catalog.
- The Search Attributes for items in the Core, Bonus, and Manufacturer Catalogs are no longer editable.

## SYMBOL OBJECTS

- The Symbol Specification dialog's panels are now found in the Symbol Object Specification dialogs.
- New **Dedicated Circuit** requirement attribute in the Symbol Object Specification dialog for fixtures. See [Options Panel on page 994](#).

- The **Suppress Adjacent Room Moldings** option is now available for fixture and furniture objects in their specification dialog.
- Fixture and furniture symbols set to be placed on base cabinets or tables will now also place on Custom Countertops.



## OTHER OBJECTS

- 3D Solid objects can now be added to the library.



## MATERIALS

- The **Transparency** setting is now available for materials assigned the Transparent class for use in non-ray traced views.

## 3D VIEWS

- New **Below Grade Override** options for line color, style, and weight in the Cross Section/Elevation Specification dialog.
- **Virtual Reality**  is now an option in the desktop Chief Architect Viewer.
- New **Depth of Field** options allows you to add blur to out-of-focus objects in Standard, Vector View, Physically Based, Glass House, and Technical Illustration renderings.
- Position and Navigation settings were moved from the General panel to the new POSITIONING panel in the Camera Specification dialog.
- New **Depth Cue**  tool applies a partially transparent mask over surfaces located past a set distance from a cross section/elevation camera.
- New **Extend Terrain to Horizon** option for camera views.
- When Camera Bumps of Walls is enabled, new **Turn Automatically** option controls whether cameras also change direction when they approach walls, doors, and staircases.
- The **Framing Back Clip** distance can now be set for individual cross section/elevation views rather than plan-wide.

## 3D RENDERING AND RAY TRACING

- New **Denoise View**  tool removes light artifacts and the appearance of graininess from active GPU Ray Trace views.
- Improved Generated Sky simulates the sky at different times of day based on the position of the Generic Sun.
- New **Move Sun**  tool lets you adjust the Generic Sun's position in camera views using the mouse.
- The moon and stars are now represented in nighttime camera views when the Generated Sky is in use. The new **Move Moon**  tool lets you adjust the moon's position.
- The color of Opaque Window Glass can now be specified.
- New **Automatic** and **Manual Exposure** settings for Physically Based and Clay renderings.
- Light sources' **Show Position in Camera View** status can now be set in the Adjust Lights dialog.
- Totals for Light Objects, Light Sources, and In Use lights are now reported in the Adjust Lights dialog.
- The Line Drawing Rendering Technique has been renamed **Hand Drawn Lines**.
- The minimum Hand Drawn Lines Thickness has been lowered to 0.25.
- **Soft Sun Shadows** can now be specified in GPU Ray Trace Views.



## PICTURES, IMAGES, AND WALKTHROUGHS

- Plants and other image objects can now be assigned 2D CAD blocks from the Library.
- Imported PDF boxes now have labels and an object preview in their specification dialog.
- Picture objects now have labels and an object preview in their specification dialog.
- Imported Picture and PDF Boxes are now placed on the "Picture/PDF Boxes" layer by default.
- The obsolete Black and White Dither option has been removed from the Picture File Box Specification dialog.
- Spherical Panoramic Backdrops can no longer be used in Orthographic Overviews.

## TERRAIN

- New **Grass Region**  tools create regions of realistic generated 3D grass.

## MATERIALS LIST

- New Live Materials List is dynamically linked to the model and updates as changes are made.
- The **Font**, **Colors**, and **Grid** style for Materials Lists can now be specified for each list in its specification dialog rather than globally.

## LAYOUT

- **Send to Layout** is now an option in a selected view's contextual menu in the Project Browser.
- New **Send All Remaining Views to Layout With These Settings** check box lets you send multiple views to layout with one instance of the Send to Layout dialog.
- The LAYER SET panel in the Layout Box Specification dialog is now available when multiple layout boxes are selected.

## RUBY IN CHIEF ARCHITECT

- New NVPS for walls, doors, stairs, fixture objects, and callouts/notes/construction lines.

# Index

- 3
- 360 Panorama Export *1238*
- 3D
  - Backdrops *1122*
  - Box *1015*
  - Data Import *999*
  - Delete Surface *1099*
  - Face *1015*
  - Mice *15*
  - Symbols, Importing *998*
- 3D Molding Polyline *935-936*
  - Specification Dialog *939*
- 3D Roof Designer *808*
- 3D Solid
  - Specification Dialog *1022*
- 3D View Defaults Dialog *1083*
- 3D Views
  - Display *1097*
  - Editing *1109*
  - Floor Overview *1087*
  - Framing Overview *1088*
  - Full Overview *1087*
  - Line Weights *1375*
  - Overviews *1085*
  - Save *1115*
  - Working in *1109*
- 3D Wall Designer *357*
- 3DS Files
  - Export *1005*
- A**
- Absolute Location
  - New point *296*
- Active Layer Display Options *185*
- Active Layer Set Control *182*
- Add Break
  - partial *255*
- Add to Style Palette *280*
- Added Lights *1136*
- Adding
  - Floor Between Existing Floors *733*
  - to the Library *965*
  - Toolbar Buttons *134*
- Adjust
  - Effects *1180*
  - Image Properties *1179*
  - Material Definition *1058*
  - Wall Angle *113*
- Adjust Lights Dialog *1140*
- Advanced
  - Splines *237*
- Alcove Roofs *832*
- Align
  - Curved Stairs Between Floors *253*
  - Curved Walls Between Floors *376*
  - Objects *246*
  - Pony Walls Between Floors *377*
  - Roof Edges *810*
  - Text *513*
  - Walls *375*
- Align/Distribute Along Line *248*
- Align/Distribute Objects *246*
- Allowed
  - Angles Dialog *270*
- Alpha Channel *1069*
- Alphabets
  - International *496*
  - Unicode *496*
- Ambient Light
  - Daytime *1137*
  - Interior *1137*
  - Nighttime *1137*
- Angle Snap Grid *163*
- Angle Snaps *162*
- Angled Front Cabinets *641*
- Angles
  - Entered as bearings *302*
- Angular Dimensions *260, 470, 484*
- AO Maps *1050*
- Appearance Preferences *95*
- Appliances
  - Built into cabinets *623*
- Apply Properties *282*
- Arc
  - Creation Modes *307*
  - Panel *312*
  - Specification Dialog *311*
  - Tools *309*
  - with Arrow *311*
- Architectural Block
  - Specification Dialog *1010*
- Architectural Blocks *1007*
  - Components *1013*
  - Displaying *1008*
  - Edit Sub-Objects *1010*
  - Explode *1010*
  - Sub-objects *1013*
- Architectural Preferences *113*
- Archive Files *43*
  - Manage Auto Archives *43*
- Arcs
  - Aligning Centers *253*
  - Arc About Center *309*
  - Arc Creation Modes *307*
  - Lock Center *223*
  - Make Arc Tangent *252*
  - Show Arc Centers *223*
  - Start and End Points *116*
  - Tangent, make *374, 377*
- Area
  - Living Area calculation *416*
  - of a Polyline *317*
  - of Roof Planes *818*
  - of Rooms *423*
- Arrow
  - Auto Positioning *520*
  - Panel *327*
- Arrowheads *327*
- Artwork
  - Creating textures *1063*
- Attic
  - Floor *738*
  - Rooms *416*
  - Trusses *910*
  - Walls *380*
- Auto
  - Archive *42, 106*
  - Check for Program Updates *103*
  - Detail *1094*

Dormer Tool 839  
Dormers, Editing 840  
Elevation Dimensions 473  
Elevation Views 1091  
Exterior Elevations 1091  
Floating Dormer 838  
Floating Dormer Tool 838  
Place Corner Boards 921  
Place Outlets 671  
Place Quoins 923  
Roof Returns 844  
Room Dimensions 473  
Save Files 44, 105  
Stairwell 769

Auto Generate Sidewalks 1287

Auto Rebuild  
Attic Walls 344  
Framing 855  
Roofs 796  
Terrain 1256  
Walls/Floors/Ceilings 735

Automatic  
Framing 854  
Roofs 792  
Roofs vs. Manual Roofs 792

**B**

Back Clipped Cross Section 1089

Backdrops 1204  
3D 1122  
Definition 1204  
Panoramic 1205

Background Color 98

Backup  
Entire Plan or Layout 55  
Files 42

Balloon Through Ceiling 396

Balusters 407  
Definition 745

Base  
Cabinets 621

Baseline  
Dimensions 471  
Polylines (Roofs) 819  
Roofs 805

Basements  
Daylight 718  
Walkout 718

Bay Windows 578

Bay/Box Window  
Specification Dialog 613

Beams  
Bearing 888  
Floor/Ceiling 859  
Roof 858

Bearing  
Beam 888  
Line 878  
Wall 397

Bearings 302

Behaviors Preferences 118

Birdsmouth  
Cut 809

Blend Colors with Materials 1054

Blind Cabinets 642  
Automatic 620

Blocking  
Joist 859  
Roof 858  
Wall 864

Blocks  
Architectural 1007  
Architectural vs CAD 1008  
CAD 329  
Mulled Doors and Windows 556

Bonus  
Library Catalogs 961  
Rooms 738

Borders (Layout) 1358

Bounding Box 983

Bow  
Front Cabinets 642  
Window Specification 613

Bow Windows 578

Box  
Tools 319  
Windows 578

Break  
Line 254  
Line, complete 255  
Terrain Breaks 1250

Brick Ledges 353

Build  
Foundation 710, 734  
Framing Dialog 860

House 63  
New Floor 732  
Roof Dialog 797  
Terrain 1256

BuilderTREND 1327

Bump Maps 1050

Bumping/Pushing 243

**C**

Cabinet  
Defaults 618  
Designer 617  
Hardware Size 659  
Modules Library 623  
Molding Polylines 638  
Shelf Specification Dialog 658  
Specification Dialog 643  
Tools 621

Cabinets  
Angled front 639  
Backsplash 645  
Base 621  
Bevel 654  
Blind 642  
Blind Corners, automatic 620  
Built-in appliances 623  
Corner 639  
Countertop, custom 622, 627  
Countertops 627  
Delete face items 650  
Door/drawer style 623  
Doors, diagonal 646  
Doors, glass 653  
Editing 634  
End cabinets 639  
Exposed End 640  
Fillers 624  
Fillers, automatic 620  
Frameless 647  
Front Indicators 628  
Front/Sides/Back Panel 648  
Full Height 621  
General Defaults 619  
Glass doors 653  
Island 642  
Labels 630  
Lazy Susan 646  
Minimum Width 620  
Module Lines 629  
Module lines, partial 621  
Moving, with Wall 636  
Opening Indicators 629  
Panels 648  
Peninsula radius 639

- Pilasters 655
  - Radius end 639
  - Resize Increment 621
  - Reverse Appliance 652
  - Schedules 630
  - Separation 647
  - Shelves 658
  - Special shapes 639, 644
  - Stile 653
  - Toe kick 646
  - Wall 621
- CAD
- Angle Snaps 162
  - Angles in Degrees/Bearings 292
  - Blocking box 320
  - Blocks 329
  - Box 320
  - Circle about center 314
  - Circle Tools 314
  - Circles 314
  - Convert to Terrain 1282
  - Cross box 320
  - Current CAD Layer 326
  - Current Point 298
  - Delete Current Point 298
  - Drawing Tools 295
  - Ellipses 315
  - Extend Object(s) 273
  - Fillet 257
  - In Layout 1337
  - Line Length Format 292
  - Lines 300
  - Ovals 315
  - Points, moving 298
  - Polylines 316
  - Preferences 114
  - Rectangular Polyline Tool 319
  - Resize 118
  - Rotate around 119
  - Rotate items 118
  - Rotate Jump 119
  - Stretch 271
  - Temporary Points 298
  - to Walls 262, 383
  - Trim Object(s) 272
- CAD Block 329
- Add to library 332
  - Edit 330
  - Explode 330
  - Insert 333
  - Insertion Point 336
  - Make CAD Block 330
  - Management 333
  - Nested 329
  - Purge unused 334
  - Select Insertion Point 331
- Specification Dialog 334
- CAD Block Window 330
- CAD Box
- Specification Dialog 320
- CAD Defaults 291
- CAD Detail 337
- from View 338
  - Management Dialog 337
  - Truss Detail 901
- CAD Objects
- Converting 262
  - Displaying 325
- Calculate
- From All Floors 1304
  - From Room 1304
  - Loan 73
- Callout
- Arrows 522
  - Defaults 495
  - Specification Dialog 526
- Callouts 521
- Linked 524
- Camera
- Activating 1115
  - Create Views 1086
  - Defaults 1081
  - Field of View 1108
  - Move Tools 1103
  - Move Up/Down One Floor 1107
  - Orbit Tools 1104
  - Plan Display Panel 1120
  - Specification Dialog 1116
  - Tilt Tools 1104
- Casing
- Door 553, 563
  - Window 590
- Cathedral Ceilings 435
- Ceiling
- Framing 860
  - Heights 426
  - Plane 826
  - Shelf 428
  - Trusses 895
- Ceiling Plane
- Specification Dialog 828
- Ceiling Structure Definition 1040
- Ceilings
- Automatic 860
- Basement 708
- Cathedral 435
- Dropped 427
- Hole in Platform 430
- Lowered 434
- Over this room 441
- Special 434
- Vaulted 435
- Center
- Doors 552
  - Object edit tool 250
  - Sheet 1372
  - Snapping to 121
  - Text 513
- Centerline Dimensions 472
- Chamfer
- Footings 401
  - Two Lines 257
- Change
- Door Swings 553
  - Floor/Reference 69, 737, 739
  - Line to arc 754
  - Scale 1347
  - Wall Types for Pony Walls 355
- Check
- Plots 1364, 1373
  - Spelling 518
- Chief Architect
- Viewer 31
- Chimneys 728
- Circle
- Specification Dialog 315
  - Tools 314
- Circles 314
- Aligning Centers 253
  - Circle about center 314
  - Draw using center and radius 314
  - Ovals 315
- Clear Terrain 1246
- Click Stairs 744
- Close
- Plans and Views 155
  - Program 56
  - Views 155
- Color
- Off/On 191
- Color Chooser 203
- Create Material Using 203

- Color Chooser Dialog 203
  - Colors
    - Selecting 203
  - Compatibility
    - with other programs 35
  - Components 979
  - Compound Raked Walls 382
  - Concentric
    - Resizing 208
  - Concrete
    - Pour Numbers 713
  - Cone 1015
    - Specification Dialog 1028
  - Configurations Panel 136
  - Connect
    - Electrical 671
    - Walls 361
  - Construction Line
    - Specification Dialog 66
  - Construction Lines 65
  - Contextual Menus 95
    - In Render views 1107
  - Contour Lines 1256
  - Convert
    - Arc/Circle to Polyline 258
    - Cabinet Molding 936
    - CAD Lines to Terrain Data 1282
    - CAD Objects 262
    - Polyline 262
    - Polyline to Spline 266
    - Room Molding 936
    - Special Polylines into
      - Polylines 265
    - Spline to Polyline 266
    - Textures to Materials 1061
    - To Polyline Object 1288
    - to Solid 266, 1016
    - to Symbol 1002
  - Coordinate Indicators 117
  - Coordinates 166
  - Copy
    - Floors 735
    - Folders and Library Objects 968
    - Library List 961
    - Multiple Copy 172
    - Trusses 897
    - Views 1346
  - Copy Selected Material 1054
  - Copy/Paste
    - Main Edit Mode 170
    - Sticky Mode 170
  - Corner
    - Boards 921
    - Windows 580
  - Corner Board
    - Specification Dialog 922
  - Countertops
    - Custom 622, 627
    - Edge Profiles 627
    - Edit Custom 627
    - Holes in 622
  - Create
    - New Plan Dialog 38
    - Plan Database File 46
    - Plan Materials Library 1061
    - Plant Image 1297
    - Schedule from Room 683
  - Create Hole 232
  - Cross Section Lines
    - In Camera Views 1110
  - Cross Section Slider 1108
  - Cross Section Views
    - Clipping 1091
    - Stepped Cutting Plane 1092
  - Cross Section/Elevation
    - Specification Dialog 1124
  - Cross Section/Elevation Views 1089
  - Cross Section/Elevations 1085
    - Detailing 1094
    - Sent to Layout 1341
  - Crosshairs 16
    - Aligning with 249
  - Curbs 1290
  - Current
    - CAD Layer 326
    - CAD Point 298
    - Floor 737
    - Floor, Delete 735
    - Layout Page 30, 1356
  - Curved
    - Deck Edge 349
    - Deck Railing 349
    - Roof Planes 823
    - Stairs 744
    - Walls, Draw 360
  - Custom
    - Counterholes 622
    - Countertops 622
    - Countertops, Editing 627
  - Custom Backsplash
    - Specification Dialog 1038
  - Custom Countertop
    - Specification Dialog 662
  - Custom Fields 690
  - Customize
    - Hotkeys Dialog 138
    - Sheet Sizes Dialog 1370
    - Toolbars 134
  - Cylinder 1015
    - Specification Dialog 1026
- D**
- Dashboard 11
  - Deck 425
    - Designer 349
    - Edges 349
    - Framing 425, 443
    - Planking 443
    - Railing 349
    - Railing Defaults 345
    - Roof Over 425
  - Decks 425
  - Default
    - Lights 1136
    - Set as 79
    - Wall Heights 395
  - Default Sets 83
  - Defaults
    - Cabinet 618
    - Camera 1081
    - DeckRailing 345
    - Dimension 449
    - Door 544
    - Dormer 793
    - Dynamic 79
    - Electrical 667
    - Fencing 346
    - Floor 413, 731
    - Foundation 706
    - Framing 851, 860
    - General Plan 92
    - Importing 90
    - Layer Set 183
    - Layout 1334
    - Material 1051
    - Object Labels 682

- Railing 345
  - Reset 91
  - Road and Sidewalk 1284
  - Roofs 792
  - Room 413
  - Schedule 682
  - Settings 77
  - Structural Member
    - Reporting 1306
  - Wall 345
  - Window 577
- Define Material Dialog 1066
- Delete
- 3D Surface 1099
  - Built-in Fixtures and Appliances 971, 981
  - Current Floor 735
  - Current Point 298
  - Floors 735
  - Foundation 716
  - Framing 884
  - Gable Over Opening 832
  - Library Content 970
  - Objects 285
  - Objects, warning before 93
  - Roof Planes 795, 811
  - Temporary Points 298
  - Tools from Toolbars 132
  - Wall Hatching 357
- Designer/Client Information 541
- Details
- Auto Detailing 1094
  - CAD 337
  - Cross section/elevations 1094
  - Truss 901
- Dialog Number/Angle Style 126
- Dimension
- Defaults 451
  - Tools 469
- Dimension Defaults 449
- Dialog 451
- Dimension Line
- Specification Dialog 485
- Dimensions
- Add Text 482
  - Angular 260, 470, 484
  - Auto Elevation 473
  - Auto Room 473
  - Centerline 472
  - Display size 97
  - Editing 476
  - End to end 470
- Interior 470
  - Locate Objects 454
  - Locating railings 394
  - Move Objects Using 483
  - Moving Labels 477
  - Number Height 486
  - Point to point 470
  - Printing 1373
  - Running 471
  - Story Pole 473
  - Tape Measure 472
  - Temporary 473
  - Wall Layers 386
  - Wall Widths 487
  - Zeroes in 460
- Disconnect Edges 212
- Display
- 3D Views 1097
  - Arc Centers and Ends 292
  - CAD Objects 325
  - Drawing Groups 190
  - Drawing Sheet 1371
  - Electrical 673
  - Foundations 711
  - Images 1186
  - Line Weights 1371
  - Objects 177
  - Options, Layout 1334
  - Pointer CAD Coordinates 96
  - Pony Walls in Floor Plan
    - View 354
  - Roof Planes 806
  - Room labels 423
  - Terrain 1256
  - Walls, Railings, and Fences 363
- Displayed Line Length
- Dialog 293
- Distributed Object Tab 1269
- Distributed Objects 1042
- Distribution Path
- Specification Dialog 1043
- Distribution Region
- Specification Dialog 1043
- Door
- Casing 553
  - Defaults 544
  - Specification Dialog 558
  - Swing Angle 559
  - Tools 545
  - Trim 553
- Doors
- Arched 567
  - Bifold Doors 546
  - Blocked Units 556
  - Casing 563
  - Center 552
  - Change Opening/Hinge Side 554
  - Change Swing Side 555
  - Custom Symbols 547
  - Doorways 546
  - Double-swing 562
  - Frame 566
  - Framing 865
  - Gables Over 830
  - Garage 546
  - Garage, opening direction 555
  - Garage, panels 561
  - Handles 569
  - Hardware 569
  - Hinged Doors 545, 553
  - Hinges 569
  - Ignore Casing when Resizing 93
  - Labels 550
  - Library 547, 559
  - Lites 566
  - Locks 569
  - Opening Indicators 549
  - Openings in railings 556
  - Plinth Blocks 563
  - Pocket Doors 546
  - Recessed 556, 562
  - Sliding Doors 555
  - Style 559
  - Swing from Center 562
  - Swing, change 553
  - Threshold lines 548
  - Transoms 556
  - Type 559
  - Wrapped Openings 556
- Doorways
- Adding a Door 547
  - with Railing 557
- Dormer
- Defaults 793
  - Specification Dialog 841
- Dormers 838
- Auto Dormer 839
  - Auto Floating 838
  - Explode 610, 841
  - Framing 870
  - Gable Over Door/Window 830
  - Manually drawn 839
  - Windows in 840
- Double
- Trusses 909
  - Walls 382

- Draw
  - Arc About Center 309
  - Circle About Center 314
  - Curved Railing 360
  - Curved wall 360
  - Lines 300
  - Roof Planes 805
- Drawing Group
  - Edit Tools 190
  - Move to Back 190
  - Move to Front 190
  - Select 191
- Drawing Groups 190
- Drawing Sheet
  - Center 1372
  - Select 1371
  - Show 1371
- Driveways 1286
- DWG
  - File Format 1226
- DXF
  - File Format 1226
- DXF/DWG
  - Advanced Layer Mapping 1232
  - DXF vs. DWG 1226
  - Export 3D 1005
  - Files, Import 2D 1228
  - Layer mapping 1231
  - Layers, exporting 1006
  - Line Type 1238
- Dynamic
  - Defaults 27, 79
  - Print Preview 1371
  - Views 1341
- E
- Earth Data Panel 1146
- Eaves
  - Boxed 845
  - Fascia 869
  - Framing 869
  - Plumb Cut 801
  - Square cut 801
- Edit
  - All Roof Planes 795
  - Files in Home Designer 93
  - Handles 23
  - Layout Lines 1348
  - Layout Lines Dialog 1348
  - Paper Size Dialog 1370
  - Preferences 115
- Text in Place 512
- Edit Active View 145
- Edit Area
  - (All Floors) 269
  - (All Floors) Visible 269
  - Polyline as marquee 269
  - Tools 269
  - Visible 269
- Edit Behaviors 206
  - Alternate 207
  - Concentric 208
  - Default 206
  - Edit Indicators 119
  - Fillet 209
  - Move 207
  - Resize 208
- Edit CAD Block 330
- Edit Handles
  - Same Line Type 303
  - Size 116
  - Tolerance 116
- Edit Text Macro Dialog 1397
- Edit Wall Cutout Polyline 985
- Egress Windows 594
- Electrical
  - Auto Place Outlets 671
  - Connections 671
  - Defaults 667
  - Deleting 675
  - Displaying 673
  - Editing Objects 674
  - General 666
  - Labels 673
  - Library 672
  - Lights 669
  - Outlets 668
  - Switches 669
  - Tools 668
  - Wiring 671
- Elevation
  - Auto Dimensions 473
  - Data Tools 1246
  - Points 1247
  - Regions 1249
  - Splines 1249
  - Tab 1264
- Elevation Data
  - Importing from DXF/DWG 1282
  - Tools 1246
- Elevation Line
  - Specification Dialog 1264
- Elevation Point
  - Specification Dialog 1263
- Elevation Region
  - Specification Dialog 1264
- Elevation Views 1089
  - Auto 1091
- Elevations
  - Interior 1085
- Elevations, Wall 1089
- Ellipse 315
  - Specification Dialog 315
- End
  - Cabinets 641
  - Caps 115
  - To-End Dimensions 470
  - Trusses 914
- Energy Heel 909
- Enhanced Metafiles 1195
- Enter
  - Coordinates 302
  - Coordinates Dialog 166
- Error Messages 1406
- Estimating Software 1327
- Exit Program 56
- Expand Room Polyline 436
- Expand/Collapse All 953
- Explode
  - 3D Solid 1020
  - Architectural Blocks 1010
  - CAD Block 330
  - Distributed Objects 1043
  - Dormers 610, 841
- Export
  - 2D Drawings 1235
  - 360 Panorama 1238
  - 3D DXF/DWG Model 1005
  - 3D Files 1005
  - 3D Viewer File 1223
  - All Floors 1235
  - Current View 1235
  - Drawing File Dialog 1236
  - EMF 1195
  - From the Library 972
  - Layers Sets 189
  - Layout Files 1362

- Materials List 1325
- Picture Files 1191
- REScheck 1240
- Structural Member
  - Reporting 1307
- Text Macros 1399
- VRML 1219
- Wall Definitions 391
- Windows Metafiles 1195
- Windows Metafiles Dialog 1195
- WMF 1195
- Extend
  - Object(s) 273
  - Slope Downward 378
- Extension Lines
  - Adding 478
  - Centerline 472
  - Deleting 480
  - Edit Extensions tool 481
  - Editing 478
- Extension Snaps 122, 161
- Extensions Panel 462
- Exterior
  - Room types 416
  - The Exterior Room 418
  - Walls 351
- Extrude
  - Object 1018
- Eyedropper
  - Object 282
- F**
- F6 Key
  - Fill Window 154
- Faces
  - 3D 1015
- Fascia 846
- Fence Designer 351
- Fence Select 215
- Fencing
  - Defaults 346
- Field of View 1108, 1220
- File
  - Backing Up Your Files 42
  - Create New 38
  - Management 34
  - Open 44
  - Organization 36

- Recent File List 105
- File Management Preferences 104
- Fill
  - Patterns 192
  - Window 154
  - Window Building Only 154
- Fill Style Panel 193
- Fillet 209
- Fillet Lines 257
- Filter
  - Imported Terrain Data 1278
- Find Object in Plan 691
- Find Plan Wizard 48
- Finding Objects 72, 211
- Fire Box Panel 727
- Fireplace
  - Library 728
  - Masonry 724
  - No Fire Box 727
  - Specification Dialog 726
  - Symbol 728
- Fireplaces 724
  - Chimneys 728
  - Foundations 726
  - Freestanding 725
  - In walls 724
  - Types 724
- Fix
  - Roofs 795
  - Wall Connections 362
- Fix Off Angle Walls 358
- Fixtures
  - Lights 669
- Flare/Curve Stairs 757
- Flat Region 1252
  - Specification Dialog 1265
- Floating Auto Dormer 838
- Floor
  - 3D Overview 1085
  - Build New Floor 732
  - Camera 1084
  - Defaults 413, 731
  - Framing 860
  - Heights 426
  - Overview 1085, 1087
  - Tools 731

- Trusses 895
- Floor Plan
  - Drawing 27
  - View 29
- Floor Structure Definition 1040
- Floor/Ceiling
  - Beam 859
- Floor/Ceiling Truss
  - Specification Dialog 916
- Floors
  - Adding 732
  - Attic 738
  - Change Floor/Reference 69, 737, 739
  - Copying 735
  - Current Floor 737
  - Deleting 735
  - Exchange With Floor Above 735
  - Exchange With Floor Below 735
  - Floor Up/ Floor Down 737
  - FloorTabs 860
  - Hole in Platform 430
  - Insert New Floor 733
  - Maximum number 732
  - Raised 427
  - Reference Floor 68, 738
- Focus on Object 1101
- Folders Preferences 106
- Follow Terrain 1260
- Font
  - Materials List 99
  - Preferences 99
- Fonts 495
  - and Alphabets 495
- Footings
  - Alignment 377
  - Chamfer 401
  - Editing 714
  - Monolithic Slab 401
  - Size 401
  - Stem wall 377
  - Stepped 381
- Footprint, Plan 339
- Foundation
  - Defaults 706
  - Panel 400
  - Thickness 401
  - Walls 352



## Foundations

- Alignment 377
- Build 710
- Daylight Basement 718
- Delete 716
- Display 711
- Footing size 401
- Garage 716
- Mixed Types 710
- Piers 708
- Rebar 709
- Slab at top of stem wall 708
- Slab thickness 708
- Slab Tools 719
- Stem Wall 708
- Step markers 708
- Stepped 718
- Types 707
- Use Mesh 709
- Walkout Basement 718

## Framing

- 3D Overview 1088
- Auto Rebuild 855
- Automatic 854
- Barge Rafter 871
- Beams 867-868
- Bearing Line 878
- Blocking Box 320
- Build Framing Dialog 860
- Butt Joints 860
- Ceiling 860
- Cross Box 320
- Deck 425, 443
- Default Fill Style 874
- Defaults 851
- Defaults Dialog 860
- Deleting 884
- Displaying 879
- Doors 865
- Dormer Holes 870
- Editing 882
- Floor 860
- Furring 383
- Girts 390
- Joist Spacing 862
- Joists 858
- Keeping current 884
- Lap Joints 860
- Lookouts 869
- Manual vs. Automatic 854
- Materials List 886
- Mitered Joints 883
- Mixing Trusses with Rafters 902
- Plates 864
- Platforms 860
- Posts 868
- Reference Marker 875

Represented by single line 874

- Rim Joist 860
- Roof 869
- Rough Openings 865
- Schedules 882
- Sill Plates 853
- Specification Dialog 887
- Steel 884, 886
- Structural Member
  - Reporting 1306
- Stud Spacing 864
- Stud Thickness 864
- Tools 856
- Trimmers 866
- Truss Spacing 874
- Trusses 872
- Types 886
- Wall Blocking 864
- Wall Bridging 857
- Wall Layer 385
- Walls 863
- Windows 865

## Frieze

- Molding 943

## Full

- Height Cabinets 621
- Overview 1085, 1087

## Furring 383

## G

### Gable

- Gable/Roof Line Tool 830
- Over Door/Window 830

### Gamepad

- Enable 140

### Gamepad Settings 140

### Gamepads 1101

### Garage

- Door panels 561
- Door Tool 546

### Garages

- Foundation 716

### Garden Bed

- Specification Dialog 1268
- Tools 1253

## General

- Cabinet Defaults 619
- Framing Tool 857
- Preferences 102
- Wall Defaults 343

Generated Sky 1123

Get Last Symbol 1002

Getting Help 31

Girder Trusses 911

## Glass

- Stained 581

## GPS

- Importing 1280

GPU Ray Tracing 1132

Grade beams 707

## Grass Region

- Specification Dialog 1270
- Tools 1253

## Grayscale

- On Screen 96
- Printed 1382

## Grid

- Snaps 163

## H

### Half

- Walls 407

Half-Walls 347

Hardiness Zone Maps 1297

### Hardware

- for Doors 569

### Hatch

- Fill Patterns 192
- Wall 357

### Height

- Basement ceiling 708
- Railings 409

### Help

- Tool Tips 31

### Hill / Valley

- Specification Dialog 1266

Hill/Valley 1252

### Hip

- Truss 908

### Holes

- Creating 232
- In ceiling platforms 430
- In floor platform 430
- In Slabs 719

In terrain *1254*  
Home Designer  
  Allow editing in *93*  
  Software Compatibility *35*

Hotkeys *137*  
  Create List *137*  
  Customize *138*  
  Snap Behaviors *160*

House Wizard  
  Editing Rooms *63*  
  Multiple Floors *64*  
  Placing Rooms *62*

## I

Image  
  Specification Dialog *1188*

Images *1134*  
  Adding to Library *1186*  
  Convert Folder *1186*  
  Creating *1186*  
  Displaying *1186*  
  Editing *1187*  
  In Schedules *694*  
  Place *1185*  
  Printing *1383*  
  Transparency Color *1190*

Import  
  2D DXF/DWG Files *1228*  
  3D Data *999*  
  3D Symbols *998*  
  Defaults *90*  
  Drawing Wizard *1228*  
  DXF/DWG Elevation Data *1282*  
  GPS Data *1280*  
  Layer Sets *189*  
  Line Styles *199*  
  Materials Folder *1061*  
  PDF *1198*  
  Structural Member  
    Reporting *1307*  
  Terrain Assistant *1277*  
  Terrain Data *1276*  
  Text Macros *1399*  
  Textures Folder *1061*  
  Wall Definitions *391*

Input  
  Arc *309*  
  Line *301*  
  Point *296*

Insert  
  Floor Dialog *733*  
  Layout Page *1356*

Insulation *320*  
  Auto Detailing *1094*  
  Show in Elevation *1094*

Interior  
  Dimension Tool *470*  
  Room types *416*

Intersection *275*

Invisible Walls *355*

Isometric Overviews *1088*

## J

Join Roof Planes *811*

Joist  
  Direction Line *876*

Joist Direction  
  Specification Dialog *877*

Joists *858*  
  Bearing Line *878*  
  Blocking *859*  
  Spacing *862*  
  Use Framing Reference *861*

## K

Key Frames *1208*

Keyboard  
  Commands *137, 953*  
  Commands, custom *138*

Kidney Shaped  
  Terrain Features *1254*

Kingpost *914*

Kitchen Island *642*

Knee Walls *380, 398*

## L

Label Panel *700*

Labels *699*  
  Cabinet *630*  
  Display size *97*  
  Displaying *700*  
  Door *550*  
  Electrical *673*  
  Plant *1301*  
  Roof Plane *807*  
  Room *422*  
  Trusses *902*  
  Window *587*

Landing *755*

Landings  
  Height *756*

Layer  
  Display Options Dialog *179*  
  Eyedropper Tool *188*  
  Hider *188*  
  Layer Sets *182*  
  Painter Tool *188*  
  Panel *186*

Layer Set  
  Control, Active *182*  
  Defaults Dialog *183*  
  Management Dialog *184*

Layer Sets  
  Exporting *189, 392*  
  Importing *189*  
  Missing in Layout *1355*  
  Modify all *183*

Layers  
  3D DWG/DXF Models *1006*  
  Adding new layers *181*  
  Colors *182*  
  DXF/DWG files *1231*  
  Locking *178*  
  Mapping *1231*  
  Primary and Secondary *177*  
  Rename *180*  
  Reset Names *180*

Layout  
  Adding Lines *1348*  
  Borders *1358*  
  CAD *1337*  
  Change Pages *1356*  
  Change Scale *1347*  
  Create Template *89*  
  Cross Section/Elevations *1341*  
  Current Page *30, 1356*  
  Defaults *1334*  
  Edit Layout Lines *1348*  
  Edit Vector Views *1348*  
  Editing Views *1345*  
  Exchange Page *1357*  
  Exporting *1362*  
  Files, Opening *44*  
  Floor plan view *1341*  
  Insert Page *1356*  
  Layout Box Layers *1345*  
  Links, Managing *1353*  
  Managing Pages *1335*  
  Missing Files *1354*  
  Missing Layer Sets *1355*  
  Moving Views *1346*  
  Open View *1335, 1347*  
  Page Display Options *1334*

- Page Information *1358*
- Page Numbering *1357*
- Page Templates *1358*
- Page Up/Down *1356*
- Page Zero *1358*
- Pictures in *1338*
- Printing *1361*
- Relink File *1354*
- Rescale Layout View *1347*
- Resizing, Non-Scaled Views *1347*
- Resizing, Scaled Views *1347*
- Saving *39*
- Sending views to *1338*
- Templates *87*
- Text *1337*
- Title Blocks *1358*
- Layout Box
  - Labels *1345*
  - Layers *1345*
  - Specification Dialog *1349*
- Layout Line Scaling *1341*
- Layout Views
  - Copy *1346*
  - Keeping views current *1341*
- Leader Lines *519*
- Left Mouse Button
  - Definition *14*
- Legacy Plans
  - Text Conversion *99*
- Library
  - Adding Folders *967*
  - Advanced Search *956*
  - Bonus Catalogs *961*
  - Content *961*
  - Deleting Content *970*
  - Export *972*
  - Filter *956*
  - Manufacturer Libraries *961*
  - Renaming Libraries *968*
  - Search *954*
  - Trash *970*
- Library Browser *946*
  - Adding Items *965*
  - Panes *946*
  - Preferences *100*
- Library Objects
  - and the Materials List *979*
  - Editing *970*
  - Placing *972*
  - Schedules *980*

- Light
  - Ambient *1137*
  - Rope *669*
  - Specification Dialog *1142*
- Light Data Panel *675*
- Light Sources *1135*
  - Added Lights *1136*
  - Default Lights *1136*
  - Fixtures *1136*
  - Point Lights *1138*
  - Spot Lights *1138*
  - Sun Angles *1143*
  - Sunlight *1136*
- Lights
  - Added *1136*
  - Adjust *1140*
  - Color *676*
  - Cut Off Angle *677*
  - Direction *677*
  - Drop Off Rate *677*
  - Fixtures *669, 1136*
  - Floor Number *1142*
  - Height *1142*
  - Intensity *676*
  - Show Position in 3D *678*
  - Turn On/Off *1139*
  - Types of sources *1137*
- Line
  - Angle Format *292*
  - CAD Drawing Tools *300*
  - Endcaps *115*
  - Length Format *292*
  - Panel *304*
  - Specification Dialog *304*
  - Start and End Points *116*
  - Styles, Importing *199*
  - Styles, Library *199*
  - Weight *1364, 1374*
  - Weight Scaling *1375*
  - Weights, Show *96, 1371*
  - with Arrow *303*
- Line Style
  - Panel *305*
  - Reverse direction *262*
- Lines
  - Reverse direction *262*
- Lites
  - Craftsman *600*
  - Diamond *600*
  - Doors *566*
  - Normal *600*
  - Prairie *600*

- Living Area *424*
  - and Room Types *416*
  - Calculation *424*
  - Delete label *424*
  - Label *424*
  - Make Polyline *424*
  - Restore label *424*
  - Show *94*
  - vs. Footprint *424*
- Load
  - Custom Muntins *590*
- Loan Calculator *73*
- Locate
  - Roof Plane Intersections *812*
- Lock
  - Arc Center *223*
  - Center *223*
  - Control Handle Angle *238*
  - Layers *178*
  - Roof planes *811*
  - Tread Depth *757*
- Lock Toolbars *133*
- Lookouts *869*
- M**
- Macros *540*
- Main
  - Edit Mode *170*
  - Layer *385*
- Make
  - Arc Tangent *252, 374, 377*
  - Cabinet Molding Polyline
    - Dialog *638*
  - CAD Block *330*
  - Living Area Polyline *424*
  - Mulled Unit *583*
  - Parallel Dialog *260*
  - Parallel/Perpendicular *250, 260*
  - Room Molding Polyline
    - Dialog *437*
- Manage
  - Auto Archives *43*
  - CAD Blocks *333*
  - CAD Details *337*
  - Custom Fields *690*
  - Layout Links *1353*
  - Materials Lists *1324*
- Manual
  - Dimensions *470*
  - Roofs *792, 804*

- Manufacturer Libraries *961*
- Marker *529*
  - Defaults *495*
  - Editing *529*
  - Framing Reference *875*
  - Specification Dialog *531*
  - Types *531*
- Marquee Select *213*
- Marquee Select Similar *214*
- Marriage Walls *382*
- Masonry
  - Fireplace *724*
  - Stairs *768*
- Master List *1327*
  - File Location *123*
  - Name of file *123*
  - see also Materials List *123*
  - Update to *1328*
- Match Properties *282*
- Material
  - Defaults *1051*
  - Eyedropper *1053*
- Material Painter *1052*
  - and Walls *1054*
  - Blending *1054*
  - Modes *1053*
  - Using *1053*
- Material Region
  - Specification Dialog *1038*
- Materials
  - Add to Library *966*
  - Artwork *1063*
  - Blending *1061*
  - Creating *1060*
  - Define Material Dialog *1066*
  - Editing *1058*
  - Mapping *1062*
  - On Soffits *1034*
  - Panel *1055*
  - Patterns *1067*
  - Plan Materials Dialog *1064*
  - Polyline *1322*
  - Render properties *1072*
  - Stained glass *581*
  - Textures *1069, 1134*
  - Types *1063*
  - Walls *365*
- Materials List *1303*
  - Calculate from All Floors *1304*
  - Calculate from Room *1304*
- Columns, editing *1317*
- Display Options Dialog *1312*
- Editing *1319*
- Estimating software *1327*
- Export *1325*
- Export to BuilderTREND *1327*
- Font *99*
- Framing *886*
- Library Objects *979*
- Manage *1324*
- Master List Preferences *123*
- Restrict to Floor *1314*
- Restrict to Supplier *1314*
- Save *1324*
- Saving *1304*
- Menus *18*
- Mesh, in Foundations *709*
- Message Boxes
  - Reset *25*
- Metafile Size Dialog *1195*
- Metafiles *1195*
- Metal Maps *1050*
- Middle Mouse Button *15, 153*
- Missing Layer Sets Dialog *1355*
- Mitre Ends of Angle Walls *865*
- Modify
  - All Layer Sets *183*
  - Plan Database File *47*
- Molding
  - 3D Molding Line tool *936*
  - 3D Molding Polyline *936*
  - Frieze *943*
  - Place Molding Profile *933*
  - Polyline Specification Dialog *938*
  - Profiles *932*
  - Profiles, changing *926*
  - Profiles, custom *932*
  - Specification *931*
  - Symbol *934*
- Molding Line tool *935*
- Molding Polyline
  - Specification Dialog *938*
- Molding Polyline tool *935*
- Moldings
  - Built Up *933*
  - Library *936*
- Moldings Panel *446, 927*
- Mouse
  - 3D *15*
  - Cursor Icons *16*
  - Pointer Icons *16*
- Mouse Buttons
  - Using *14*
- Move
  - Along Rails *370*
  - CAD Points *298*
  - Camera with Mouse *1101*
  - Folders and Library Objects *968*
  - Nudging *244*
  - Object Using Dimensions *483*
  - Objects *243*
  - Restrictions *244*
  - to be Coplanar *813*
  - to Framing Reference *246*
  - Views to a Different Page *1346*
  - Walls with Cabinets Attached *636*
- Move Point Dialog *298*
- Mulled Unit
  - Specification Dialog *592*
- Mulled Units
  - Framing *594*
  - Labels *701*
  - Mullion Depth *594*
  - Treat as Door *594*
- Mullions
  - Window *599*
- Multiple
  - Copy *172*
  - Select *213*
- Multiple Copy Dialog *173*
- Muntins
  - Custom *590*
  - Load Custom *590*
  - Window *599*
- N
- Named Values *1389*
- New
  - CAD Arc Dialog *310*
  - CAD Line Dialog *301*
  - CAD Point Dialog *297*
  - Layer Name Dialog *181*
  - Plans Preferences *108*
  - Polygon Shaped Room *356*
- Newels
  - Definition *745*

Newels/Balusters Panel 409

Niche 579

No Locate Wall 394

Normal Maps 1050

North Pointer 1143

Nudging 244

Number Style/Angle Style  
Dialog 126

## O

Object

Based Design 13  
Layer Properties 187

Object Snaps 160  
Extension Snaps 122, 161  
Object locations 161  
Preferences 119

Objects

Distributed 1042

Off Angle Walls 358

One-Click Stairs 744

Open

Below 416  
Layout 44  
Object 21  
Plan Files 44  
Symbol 986  
Template Files 87  
View 1115

Open Row Object edit button 686

Organizing

your Files 36

Orthogonal Views 1372

Outlets 668

Above cabinet 669  
Automatic 671  
Dishwasher 669  
Manually placed 668  
Place 671  
Sink 669  
WP 669

Oval 315

Specification Dialog 315

Overview 10

Floor 1087  
Full 1087

Isometric 1088

## P

Page

Down 1356  
Up 1356

Page Setup Dialog 1367

Painting

Over Materials 1061

Pan

Pan Window Tool 155  
the Display 154  
Using the Keyboard 154  
Using the Mouse 154  
Using the Scrollbars 155

Panels

Cabinets 648

Panorama Export 1238

Paragraph Options Dialog 503

Partition Tool 622

Pass-Through 579

Paste 168

Hold Position 171  
Special 171

Paste Image 168

Pattern Editor

Preferences 101

Pattern Panel 1067

Patterns

Custom 196  
Mapping 1062

Patterns and Textures 1062

PDF 1198

Importing 1198  
Print to 1374

Peninsula Radius Cabinets 641

Personal Tutor 1405

Picture File Box

Specification Dialog 1193

Picture Files

Export 1191  
Import 1192  
Scale 1201

Pier/Pad

Specification Dialog 723

Piers

and Pads 719  
Foundation 708

Piers and Pads

Editing 722

Pitch

Above Wall 378

Place

Gable Over Window(s) 581  
Images 1185  
Library Object Button 975  
Library Objects 972  
Outlets 671

Plan

Create New 38  
Database File 46  
Drawing 27  
Files, Opening 44  
Find Plan Wizard 48  
Footprint 339  
General Defaults 92  
Materials Dialog 1064  
Saving 39  
Templates 87  
Trace 1202  
View 29

Plan Check 72

and room labels 417  
Dialog 73  
Hold 73  
Restart 73

Plan Footprint

Specification Dialog 340

Plan View

New 146

Plan View Specification Dialog 148

Plant

2D Symbols 1298  
Chooser Dialog 1295  
Encyclopedia 1295  
Labels 1301  
Specification Dialog 1301  
Tools 1294

Plant Image

Create 1297  
Specification Dialog 1297

Plant Shelf 428

- Plinth Blocks 563
- Plot Plan
  - North pointer 1143
- Plotters 1364
- Point
  - Light 1138
  - Markers 298
- Point to Point
  - Dimensions 470
  - Move 245
  - Resize 1202
- Pointer
  - Coordinates 25, 96
  - Crosshairs 16
- Polygon
  - Shaped Deck 350
- Polyline
  - 3D Molding Polyline 936
  - Area 317
  - Definition 316
  - Edit Area 269
  - Panel 317
  - Room Polyline 436
  - Specification Dialog 317
- Pony Walls 354
  - Change wall types 355
  - Dimensioning 370
  - Display 354
- Post 857
  - With Footing 857
- Preferences
  - Appearance Panel 95
  - Architectural Panel 113
  - Behaviors Panel 118
  - CAD Panel 114
  - Colors Panel 98
  - Definition of 78
  - Dialog 95
  - Edit Panel 115
  - File Management Panel 104
  - Folders Panel 106
  - Font Panel 99
  - General Panel 102
  - Global settings 95
  - Library Browser Panel 100
  - Master List Panel 123
  - New Plans Panel 108
  - Pattern Editor Panel 101
  - Render Panel 124
  - Reset preferences 125
  - Ruby Panel 108
- Snap Properties Panel 119
- Text Panel 101
- Time Tracker Panel 112
- Unit Conversion Panel 109
- Primitive Tools 1015
  - Box 1015
  - Cone 1015
  - Pyramid 1015
  - Sphere 1015
- Primitives
  - Editing 1017
  - Face 1015
- PrimitiveTools
  - Cylinder 1015
- Print 1363
  - 3D Views 1372
  - Across Multiple Pages 1374
  - Center Sheet 1372
  - Check Plots 1364, 1373
  - Clear Printer Info 1365, 1367
  - Color or Black and White 1382
  - Custom Sheet Size 1370
  - Dialog 1380
  - Dimensions 1373
  - Drawing Scale 1364
  - Drivers 1365
  - Layout 1361
  - Line Weights 1374
  - Line Weights and Scaling 1375
  - Options 1366
  - Paper Size 1364
  - Perspective Views 1372
  - Plotters 1364
  - Preview 1371
  - Printable Area 1372
  - Scale to Fit 1372
  - Services 1362
  - Sheet Size 1364, 1370
  - Terminology 1364
  - Text 1373
  - Tiled 1374
  - To File 1365
  - to PDF File 1374
  - To Scale 1372
- Print Image 1116
  - Dialog 1383
- Print Size Calculator 513
- Printers 1364
  - Select Printer 1381
- Priority Support 1406
- Profile Plans 87
- Program Updates
  - Auto Check 103
- Project Browser 58
- Property lines
  - North pointer 1143
- Pyramid 1015
  - Specification Dialog 1030
- Q**
- Quoin
  - Specification Dialog 923
- Quoins 923
- R**
- Radius
  - End Cabinets 641
  - of Tangent Curved Wall
  - Dialog 374
- Rafter Tails 847
  - Decorative Profiles 803
- Rafters 857
  - Barge 871
  - Bearing Line 878
  - Blocking 858
  - Mixing with Trusses 902
  - Use Framing Reference 870
- Rail Style Panel 407
- Railing
  - Defaults 345
- Railings 349
  - Balusters 407
  - Cable 350
  - Decks 349
  - for Stairs 779
  - Glass 350
  - Half Walls 347
  - in a Doorway 557
  - Locate with dimensions 394
  - Middle Rail 407
  - Newels 409
  - Open 407
  - Openings 556
  - Solid 407
  - Stairs 765, 783
  - Type 407
- Raised / Lowered Region
  - Specification Dialog 1268
- Ramp
  - Slope 786

- Specification Dialog 784
- Ray Trace
  - Adjust Effects 1180
  - Adjust Image Properties 1179
  - Aspect Ratio 1172
  - Assistant 1176
  - Configurations 1169
  - CPU Usage 125
  - Create 1168
  - Multiple Views 1182
  - Options Dialog 1171
  - Saving Images 1168
  - Speed, increasing 1182
  - Window 1169
- Ray Tracing
  - GPU 1132
- Rebar
  - In Foundations 709
- Rebuild 796
  - 3D 1110
  - Roof Framing 822
  - Roofs 796
  - Walls/Floors/Ceilings 735
- Recent File List 105
- Recessed
  - Doors 556, 562
  - Windows 581, 595
- Rectangular Polyline 319
- Redo 289
- Reduced Gable 914
- Reference
  - Grid 94
- Referenced Plan Files Dialog 52
- Reflect
  - About Object 261
  - Objects 261
- Regular Polygon 319
- Relative
  - to Current Point, new point 296
- Remove
  - Backdrop 1123
- Render
  - Added Lights 1136
  - Daytime Ambient 1137
  - Interior Ambient 1137
  - Light Fixtures 1136
  - Light Sources 1135
  - Nighttime Ambient 1137
- Preferences 124
- Status 125
- Tips 1132
- Rendering Techniques 1150
  - Defaults 1153
  - Options 1153
- Replace from Library
  - Button 977
  - Dialog 977
- REScheck
  - Export 1240
- Reset
  - Defaults 91
  - Message Boxes 25
  - Preferences 125
- Reshape objects 254
- Resize
  - Factor 1202
  - House using Dimensions 484
  - Objects 253
  - Point to Point 1202
- Restore
  - Toolbars 133
- Restrictions
  - Moving objects 244
- Retain
  - Wall Framing 397
- Retaining Wall 1255
- Reverse
  - Plan 147
- Reverse Direction 262
- Revision Cloud
  - Specification Dialog 322
- Revision Clouds 321
- Revision Specification Dialog 1360
- Revolve Object 1018
- Rich Text
  - Border Color 504
  - Defaults 494
  - Specification Dialog 500
  - Text Color 501
- Right Button Definition 14
- Rim Joist 860
- Road
  - Defaults 1284
- Specification Dialog 1289
- Road Marking
  - Specification Dialog 1291
- Road Tools 1284-1285
- Roads 1285
  - Convert to Polyline Object 1288
  - Curbs 1290
  - Displaying 1287
- Roof 791
  - Automatic 792
  - Baseline Polyline 819
  - Baseline Polyline, Example
    - Using 820
  - Baseline, Angled 816
  - Baselines 805
  - Beams 858
  - Birdsmouth Cut 809
  - Birdsmouth Depth 816
  - Extend Slope Downward 398
  - Full Gable Wall 398
  - Groups 795
  - Over this room 441
  - Panel 398
  - Pitches in Degrees 849
  - Second pitch 399
  - Styles, Automatic 795
  - Tools 793
  - Truss 895
  - Truss Details 901
  - Truss Specification Dialog 912
- Roof Baseline
  - Specification Dialog 821
- Roof Designer 794
- Roof Hole/Skylight
  - Specification Dialog 835
- Roof Plane
  - Labels 807
  - Specification Dialog 814
- Roof Planes 794, 804
  - Aligning 810
  - Area 818
  - Curved 823
  - Delete 811
  - Display 806
  - Edit 808
  - Intersections, Locate 812
  - Join 811
  - Low roof planes 800
  - Move to be Coplanar 813
- Roof Truss
  - Specification Dialog 912

Roofs 791, 796  
Auto Rebuild 796, 798  
Auto Roof Return 399  
Automatic vs. Manual 792  
Boxed Eaves 845  
Build Roof Dialog 797  
Crickets 840  
Defaults 792  
Dormers 838  
Eaves, aligning 813  
Edit All Roof Planes 795  
Energy Heel 909  
Fascia 846  
Fix Roofs Tool 795  
Framing 869  
Gutters 846  
Heights 814  
Hip Trusses 908  
Holes 834  
Ignore Top Floor 800  
Knee walls 380  
Lock roof planes 800, 811  
Manual 804  
Minimum Alcove Size 801  
Over Alcoves 832  
Over curved walls 796  
Overhang 800  
Pitch 378, 814  
Plumb Cut Eaves 801  
Rafter Tails 847  
Raise off plate 799  
Retain edits 816  
Returns 844  
Roof Group 439  
Roof Plane 794  
Shadow Boards 846  
Show pitch as degrees 799  
Skylights 834  
Soffits 871  
Square Cut Eaves 801  
Step Down Hip 908  
Story-and-a-half 380  
Subgirders 909  
Trusses 799  
Vertical Rafter Depth 816

## Room

Defaults 413  
Dimensions, Auto 473  
Molding Polylines 436  
Polylines 436  
Specification Dialog 437

Room Elevation Views 1090

## Room Labels 422

Custom 422  
Defaults 415  
Dimension Format 510

Display 423  
Edit 423  
Interior room area 423  
Interior room dimensions 423  
Room area 423  
Standard room area 423

## Rooms

Area 423  
Attic 416  
Below Stairs 770  
Editing 419  
Exterior types 416  
Flat Ceiling over 441  
Interior 416  
Interior area 423  
Interior dimensions 423  
Living Area 416  
Moldings 446  
Name for PlanCheck 73  
Open Below 416  
Polygon Shaped 356  
Roof over 441  
Room Definition 413  
Room Types 416  
Selecting 418  
Standard area 423  
The Exterior Room 418  
Types 415

Rope Lights 669

## Rotate

CAD items 119  
Jump 119  
Plan View 147

Rotate objects 259

Rough Opening 572

Rough Openings 865

Roughness Maps 1050

## Ruby

Console 1399  
Named Values 1389

Ruby Preferences 108

Running Dimensions 471

## S

## Same

Height Eaves 800  
Roof Height at External Wall 800

Same Line Type edit handles 303

## Sample Plans

Download 1405

## Save

3D Views 1115  
and Save As 39  
Layout 39  
Materials Lists 1324  
Plan 39  
Plan as Template 89  
Thumbnail Image 36

Save Active View 145

Saved Defaults Dialog 80

## Scale

Picture Files 1201  
Printing to 1372  
Terrain Data 1279  
Text Size 513  
to Fit 1372

## Schedule

Defaults 682  
Specification Dialog 692

## Schedules

Creating 682  
Images in 694

Schematics, Wiring 671

Scissors Trusses 911

Screen Capture Setup Dialog 1203

Scrollbars 155

## Seat

in Bay Window 610

Section Views 1089

Segment Angle at Curved Wall 801

## Select

All 215  
Backdrop 1123  
Components of Blocked  
Units 584  
Fence Select 215  
Insertion Point 331  
Library Object Dialog 974  
Marquee 213  
Material Dialog 1056  
Multiple Objects 213-214  
Next Object 211  
Objects button 211  
Objects in 3D Views 1109  
Room 418  
Same Type 282  
Selected Edge 212



- Similar Objects 212
- Similar Objects Dialog 282
- Select Color Dialog 203
- Select Drawing Group 191
- Select Layer Dialog 186
- Selection Fill Color 98
- Send
  - to Layout Dialog 1339
  - Views to layout 1338
- Set Angular Dimension Dialog 260, 484
- Set as Default 79
- Set Baseline Height Dialog 813
- Set Chamfer Distance 257
- Set Fillet Radius 257
- Setup
  - Screen Capture 1203
- Shadow Boards 846
- Shadows 1133
  - Ray Casted 1133
  - Sun 1144
- Shelf 622
- Shelf Ceiling 428
- Shelf Tool 622
- Shelf/Partition
  - Specification Dialog 660
- Shelves in Cabinets 658
- Shift Key
  - Marquee selection 213
- Shortcut Keys 137
- Show
  - Arc Centers 223
  - Line Weights 96, 1371
  - Living Area 94
  - Reference Grid 94
  - Sheet 1371
- Shutters 604
- Side Window
  - Docking 18
- Side Windows 17
- Sidewalk 1286
  - Defaults 1284

- Sill Plates 853
- Sky 1123
- Skylights 794, 834
- Slab
  - At top of stem wall 708
  - Foundation 708
  - Monolithic, Footings 401
  - Pour Numbers 713
  - Specification Dialog 720
- Slabs
  - and the Materials List 720
  - Holes 719
  - Interior Footings 715
  - Slab Tool 719
  - Tools 719
- Sliding Doors 546
- Sloped Soffits 1035
- Snap Behaviors 159
  - Angle Snaps 162
  - Extension Snaps 122, 161
  - Grid Snaps 163
  - Hotkeys 160
  - Object locations 161
  - Object Snaps 160
  - Wall Intersections 161
- Snap Properties
  - Preferences 119
- Soffit
  - Defaults 1033
  - Specification Dialog 1034
- Soffits 622, 1033
  - Calculating Materials 1034
  - Corner 1033
  - Roof 871
  - Sloped 1035
- Solid
  - Definition 1022
  - Tools 1015
- Space Planner
  - Toolbar Configuration 130
- Space Planning 62
- Spacing
  - Joists 862
  - Wall Framing 864
- Specification Dialogs
  - 3D Molding Polyline 939
  - 3D Solid 1022
  - Arc 311

- Architectural Block 1010
- Bay/Box Window 613
- Board 1309
- Bow Window 613
- Cabinet 643
- Cabinet Shelf 658
- CAD Block 334
- CAD Box 320
- CAD Circle 315
- CAD Ellipse 315
- CAD Oval 315
- Callout 526
- Camera 1116
- Ceiling Plane 828
- Cone 1028
- Construction Line 66
- Corner Boards 922
- Cross Section/Elevation 1124
- Custom Backsplash 1038
- Custom Countertop 662
- Cylinder 1026
- Dimension Line 485
- Distribution Path 1043
- Distribution Region 1043
- Door 558
- Dormer 841
- Elevation Line 1264
- Elevation Point 1263
- Elevation Region 1264
- Fireplace 726
- Flat Region 1265
- Framing 887
- Garden Bed 1268
- Grass Region 1270
- Hill / Valley 1266
- Image 1188
- Joist Direction 877
- Layout Box 1349
- Light 1142
- Line 304
- Marker 531
- Material Region 1038
- Molding Polyline 938
- Pier/Pad 723
- Plan Footprint 340
- Plant 1301
- Plant Image 1297
- Polyline 317
- Pyramid 1030
- Quoins 923
- Raised/Lowered Region 1268
- Ramp 784
- Revision 1360
- Revision Cloud 322
- Rich Text 500
- Road 1289
- Road Marking 1291
- Roof Baseline 821

- Roof Hole/Skylight 835
  - Roof Plane 814
  - Room 437
  - Schedule 692
  - Shelf/Partition 660
  - Slab 720
  - Soffit 1034
  - Sphere 1025
  - Sprinkler 1302
  - Stair Landing 787
  - Staircase 771
  - Sun Angle 1145
  - Symbol Object 986
  - Terrain 1258
  - Terrain Break 1272
  - Terrain Feature 1268
  - Terrain Path 1273
  - Text 506
  - Truss Base 907
  - Wall 392
  - Wall Hatch 411
  - Window 591
- Spell Check 517
  - Sphere 1015
    - Specification Dialog 1025
  - Splines 324
    - Advanced Splines 237
    - Control Handles 237
    - Lock Control Handle Angle 238
  - Split
    - Level Entries 737
    - Level Floor Plans 736
  - Spot Light 1138
  - Sprinkler
    - Designer 1301
    - Specification Dialog 1302
    - Tools 1301
  - Stacked Windows 582
  - Stair
    - Landing Specification Dialog 787
    - Sections Move Independently 113
    - Tools 743
  - Stair Designer 743
  - Stair Landing
    - Specification Dialog 787
  - Stair Landings
    - Height 756
  - Stair Railing
    - Middle Rail 767
    - Panels 767
  - Partial 766
  - Solid 765
  - Stair Treads
    - Automatic 772
    - Depth 774
    - Lock Number 772
    - Lock Tread Depth 772
    - Number 774
    - Overhang 775
    - Thickness 775
  - Staircase
    - Specification Dialog 771
  - Stairs
    - Align Curved Stairs 253
    - Auto Stairwell 769
    - Balusters 781
    - Change Line/Arc 754
    - Click 744
    - Concrete 768
    - Curved 744, 746
    - Curved Treads 760
    - Deck to ground 747
    - Direction 746
    - Down 747
    - Edit Handles 751
    - Editing 750
    - Flare Radius 759
    - Flared 757
    - Handrails 783
    - Landings 755
    - Large Stringer Base 777
    - Lock Tread Depth 757
    - Make Reach 771
    - Masonry 768
    - Merge Sections 753
    - Newels 781-782
    - Railings 765
    - Reach Next Floor 771
    - Rooms Below 770
    - Section Width 774
    - Stairwell 769
    - Starter Treads 761
    - Straight 743
    - Stringers 774
    - Stringers, steel 768
    - Subsections 757, 771
    - Symmetrically Flared 758
    - Terminology 745
    - Tread Depth 756
    - Treads 771
    - Walk Line 756
    - Winders 762, 774
    - Wrapped 763
  - Stairwell
    - Automatic 769
  - Static Views 1341
  - Status Bar 24, 96
    - Angle style 126
  - Steel
    - Framing 884
  - Stem Walls 708
  - Stepped Foundations 718
  - Stepping Stone
    - Tools 1253
  - Stick Framing
    - Mixing with Trusses 902
  - Sticky Mode 170
  - Story-and-a-half 380
  - Story Pole 473
  - Straight
    - Deck Edge 349
    - Stairs 743
  - Stream 1255
  - Stretch CAD 271
  - Structural Member Reporting 1306
  - Stud
    - Spacing 864
    - Thickness 864
  - Style Palettes 279
  - Subgirders 909
  - Subtraction 276
  - Sun Angle 1143
    - Create 1144
    - Render Data 1147
    - Specification Dialog 1145
  - Sun Shadows 1144
  - Swap
    - Views 150
  - Switch
    - Three way 672
  - Symbol
    - Bounding Box 983
    - Bounding box size 988
    - Categories 1003
    - Convert to 1002
    - Custom 2D 332
    - Editing Custom 980
    - Faces 991
    - Get Last Symbol 1002

- Insertion point 991
- Moldings 934
- Open Symbol 986
- Options 994
- Origin 991
- Reset origin 991
- Resizing 988
- Setback space 983
- Smoothing Angle 992
- Surface Normals 1000
- vs. Native Objects 971, 980

Symbol Object

- Specification Dialog 986

Symbols

- Inserts into 994

**T**

Tab Key 211

Tangent

- Curved walls 374, 377
- Make arc, edit button 374, 377

Tape Measure 472

Technical Support

- Contact 1405
- Error Messages 1406
- Online 1406
- Online Knowledge Base 1404
- Priority 1406
- Telephone 1406

Template Files 87

Template Layout

- Creating 89

Template Plan

- Creating 89

Templates

- Layout Page 1358

Temporary

- CAD Points 296
- Dimension Defaults 467
- Dimensions 473
- File Directories 107

Temporary Dimensions 473

Terrain

- 3D Draw Time 1257
- 3D Views 1257
- Auto Rebuild 1256
- Breaks 1250
- Build 1256
- Clear 1246

- Contour Lines 1256
- Contour Smoothing 1261
- Contours Panel 1260
- Displaying 1256
- Editing 1257
- Elevation Data Tools 1246
- Feature Tools 1252
- Flat Region 1252
- Grow All Plants Dialog 1294
- Hill 1252
- Holes 1254
- Modifier Tools 1251
- Specification Dialog 1258
- Sprinkler Tools 1301
- Toolbar Configuration 130, 1244
- Valley 1252
- Wall and Curb Tools 1254

Terrain Break

- Specification Dialog 1272

Terrain Data

- Convert CAD Lines to 1282
- Import 1276

Terrain Feature

- Specification Dialog 1268
- Tools 1253

Terrain Features

- Height 1268

Terrain Path

- Specification Dialog 1273

Terrain Perimeter 1244

Text

- Add to Dimension Label 482
- Aligning 513
- Arrows 519
- Bullets 503
- Character Size 496
- Convert Simple to Rich 512
- Copy, Cut and Paste 514
- Creating 497
- Defaults 494
- Displaying 499
- Edit in Place 512
- Editing 510
- Layer 499
- Layout 1337
- Leader Lines 519
- Line Spacing 503
- Lists 503
- Macros 540
- Maximum Characters 498
- Move 511
- Numbering 503
- Paragraph Options 503

- Printed Size 513
- Printing 1373
- Reshape 511
- Resize 512
- Rotate 511
- Scaling 513
- Specification Dialog 506
- Spell Check 517
- Tab Spacing 514
- Tabbed Objects 514
- Tables 514

Text Macro Management 1396

Text Macros

- Edit User Defined 1397
- Exporting 1399
- Importing 1399
- User Defined 1387

Text Style Defaults Dialog 538

Text Styles 538

Texture

- Filename Conflict Dialog 1001
- Panel 1069

Textures 1134

- Convert to Materials 1061
- Mapping 1062

Thumbnails 36

- Creating 36
- Enable 105
- Size 105

Tiling Views 150

Time Log Dialog 61

Time Tracker 60

- Preferences 112
- Time Log Dialog 61

Title Blocks 1358

Toolbars

- Add Tools 134
- Configurations 130, 133
- Customize 134
- Delete Tools 132
- Drop-Down 129
- Hide 129
- Lock 133
- Parent-Child 129
- Restore 133

Transform/Replicate Object

- Dialog 266

Transom Windows 556

- Transparency
  - Color 1190
- Treated
  - Lumber 888
  - Sill Plates 853
- Trim
  - Door 553
  - Window 590
- Trim Objects 272
- Trimmers 866
- Truss
  - Base 903
  - Details 901
  - Envelope 900
  - Spacing 874
- Truss Base
  - Specification Dialog 907
- Trusses 799, 872
  - Attic trusses 910
  - Copy 895, 897
  - Create 895
  - Details 901
  - Double 909
  - Drop Hip truss 914
  - Edit 898
  - End truss 914
  - Energy Heel 909
  - Floor and Ceiling 895
  - Force truss rebuild 917
  - Force Truss Rebuild 915
  - Girder 911
  - Hip 908
  - Hip jack 908
  - Jack 908
  - Kingpost 914
  - Labels 902
  - Laying out 895
  - Lock Envelope 915
  - Member Depth 913, 917
  - Mixing with Rafters 902
  - Reduced Gable 914
  - Roof 895
  - Scissors 911
  - Shape, editing 900
  - Sloping Flat 912
  - Spacing 874
  - Special Snapping 915, 918
  - Step Down Hip 908
  - Subgirders 909
  - Truss Base 903
  - Webbing 913, 917

## U

- Undo 289
  - Undo Zoom 153
- Union 274
- Unit Conversions 109
- Unrestricted Movement 244
- Updates
  - Auto Check 103
- Use Layout Line Scaling 1341

## V

- Valley 1252
- Vaulted Ceilings 435
- Vents 581
- Video Card
  - Status 125
- Videos
  - View Online Help Videos 1404
- View
  - to CAD 338
- Views
  - Static and Dynamic 1341
  - Tiling 150
- Virtual Graph Paper 92, 94
- Virtual Reality 1110
- Virtual Reality Modeling
  - Language 1219
- Visual CAD Snaps 92
- Volume
  - Of a Polyline 317
- VRML 1219
  - Export 1219
  - Textures and Images 1221

## W

- Walk Line 756
- Walkthroughs 1207
  - Along a Path 1207
  - Codecs 1219
  - Create Path 1207
  - Key Frames 1208
  - Pause Recording 1219

- Playing 1210
- Recording 1218
- Save Frame 1219
- Stop Recording 1219
- VRML 1219

## Wall

- Angles 358
- Assemblies 384
- Blocking 864
- Bridging 857
- Cabinets 621
- Caps 404
- Defaults 345
- Detail Views 880
- Elevation 1085
- Layer Fill Style 389
- Niche 579
- Specification Dialog 392
- Tools 347
- Type Definitions Dialog 387
- Types Tab 402

Wall Elevation 1089

Wall Framing

- Staggered 397

Wall Hatch

- Specification Dialog 411

Wall Type Definitions Dialog 387

## Walls

- Align between floors 376
- Align collinear 375
- and Material Painter 1054
- Attic Walls 380
- CAD to Walls 383
- Compound Raked 382
- Connecting 361
- Curved 360
- Curved, align between floors 376
- Delete hatching 357
- Dimensioning to 386
- Display surfaces only 363
- Double walls 382
- Drawing 357
- Editing 368
- Exporting Definitions 391
- Exterior and Interior 351
- Fix Connections 362
- Flip layers 358
- Footing size 401
- Foundation 352
- Foundation thickness 401
- Framing 863
- Framing Detail Views 880
- Framing Layer 385
- Full Gable Wall 398

- Furred Walls 383
- Grid snapping 359
- Half 407
- Half Walls 347
- Hatching 357
- Heights 371
- Importing Definitions 391
- Invisible 355
- Knee Wall 398
- Layers 385
- Layers, Resize About 344
- Length 371
- Main Layer 385
- Make Arc Tangent 377
- Marriage walls 382
- Materials 365
- Move Along Rails 370
- No Locate 394
- No Room Def 394
- Opening with Railing 557
- Openings in 360
- Pony Wall 354
- Raked 381
- Removing Breaks 362
- Resizing Using Dimensions 484
- Retain wall framing 397
- Retaining Wall 1255
- Reverse Layers 358
- Roofs over curved 796
- Same Wall Type handles 373
- Solid Railings 407
- Split 354
- Stepped 381
- Thickness 370
- Wall Coverings 404
- Widths, Dimensioning 487

Water Feature

- Tools 1253

Watermark 1377

Waterproof Outlets 669

Webbing

- Thickness 917

Winders 762, 774

- Definition 745

Window

- Casing 590
- Defaults 577
- Seat 610
- Specification Dialog 591
- Trim 590

Windows

- Bay and Bow dimensions 608
- Bay, Box, Bow 608

- Bench Seat 610
- Component 578, 609
- Corner 580
- Custom Muntins 590
- Custom Symbols 581
- Egress 594
- Framing 865
- Gables Over 830
- Labels 587
- Levels 585
- Library 579
- Load Muntins 590
- Make Mull Unit 583
- Match roof 601
- Minimum Separation 577
- Mulled Units 582
- Mullions 599
- Muntins 599
- Opening Indicators 587
- Pass-Through 579
- Recessed 581, 595
- Shape 601
- Shutters 604
- Special Shapes 580
- Stacked 582
- Stained glass material 581
- Standard 578
- Transom 556
- Trapezoid 601
- Treatments 603
- Types 577
- Vents 581

Windows Metafiles 1195

Wiring Schematics, Creating 671

Wrapped

- Openings 556
- Stairs 763

**Z**

Zero

- in Dimensions 460

Zoom 153

- Fill Window 154
- Mouse Wheel 15, 153
- Tools 153
- Undo Zoom 153